

ROAD WHEEL TIRE ASSEMBLY

< ON-VEHICLE REPAIR >

- Perform the ID registration, after tire rotation. Refer to [WT-5. "ID REGISTRATION PROCEDURE : Special Repair Requirement"](#).

TIRE ROTATION (for 19 inch wheel models)

- Tire cannot be rotated in vehicle, as front tire are different size from rear tire and the direction of wheel rotation is fixed in each tire.

Wheel nuts tightening torque : Refer to [WT-98. "Road Wheel"](#).

CAUTION:

- Do not include the T-type spare tire when rotating the tires.
- Use NISSAN genuine wheel nuts for aluminum wheels.

Safety Device Preventing from Being Incorrectly installed

FRONT BRAKE DISC ROTOR AND FRONT WHEEL

- Front and rear wheel size for this model differs, therefore special pin (1) has been installed on the front brake disc rotor (2). To accommodate this pin a hole (3) has been provided on the front wheel (4) (the rear wheel does not have this hole.) and in some case the rear wheel is being mistakenly installed on the front.

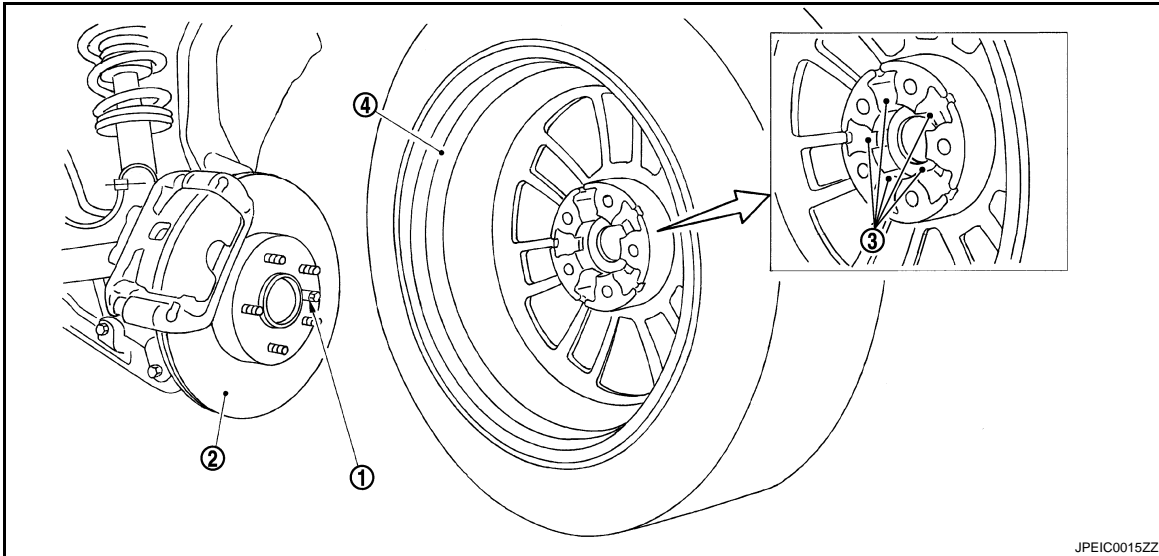

T-TYPE SPARE TIRE WHEEL

- Regarding spare tire (for emergency) wheel, wrong assembly protection pin through hole (1) has been set in addition to regular bolt holes (2) in order to enable installation to front wheel.

NOTE:

Protection pin through hole of 18 inch spare wheel is non-through type.

