

CCS

SECTION

CRUISE CONTROL SYSTEM

A
B
C
D
E
F
G
H
I
J
K
L
M
N
P

CONTENTS

<p style="text-align: center;">ICC</p> <p>PRECAUTION 5</p> <p>PRECAUTIONS 5</p> <p style="padding-left: 20px;">Precaution for Supplemental Restraint System (SRS) "AIR BAG" and "SEAT BELT PRE-TENSIONER" 5</p> <p style="padding-left: 20px;">Precautions for Removing Battery Terminal 5</p> <p style="padding-left: 20px;">Precaution for Battery Service 6</p> <p style="padding-left: 20px;">Precautions For Harness Repair 6</p> <p style="padding-left: 20px;">ICC System Service 6</p> <p>PREPARATION 8</p> <p>PREPARATION 8</p> <p style="padding-left: 20px;">Special Service Tools 8</p> <p>SYSTEM DESCRIPTION 9</p> <p>COMPONENT PARTS 9</p> <p style="padding-left: 20px;">Component Parts Location 9</p> <p style="padding-left: 20px;">ADAS Control Unit 12</p> <p style="padding-left: 20px;">ADAS Control Unit 2 12</p> <p style="padding-left: 20px;">ICC Sensor 12</p> <p style="padding-left: 20px;">ICC Steering Switch 12</p> <p style="padding-left: 20px;">Brake Pedal Position Switch / Stop Lamp Switch.... 13</p> <p style="padding-left: 20px;">ICC Brake Hold Relay 13</p> <p style="padding-left: 20px;">Combination Meter 13</p> <p style="padding-left: 20px;">Driver Assistance Buzzer 14</p> <p>SYSTEM 15</p> <p style="padding-left: 20px;">System Description 15</p> <p style="padding-left: 20px;">Circuit Diagram 20</p> <p style="padding-left: 20px;">Fail-safe (ADAS Control Unit) 21</p> <p style="padding-left: 20px;">Fail-safe (ADAS Control Unit 2) 22</p> <p style="padding-left: 20px;">Fail-safe (ICC Sensor) 22</p> <p style="padding-left: 20px;">Fail-safe (Accelerator Pedal Actuator) 22</p> <p>VEHICLE-TO-VEHICLE DISTANCE CONTROL MODE FUNCTION 22</p>	<p style="padding-left: 20px;">VEHICLE-TO-VEHICLE DISTANCE CONTROL MODE FUNCTION : System Description 22</p> <p>CONVENTIONAL (FIXED SPEED) CRUISE CONTROL MODE FUNCTION 24</p> <p style="padding-left: 20px;">CONVENTIONAL (FIXED SPEED) CRUISE CONTROL MODE FUNCTION : System Description 24</p> <p>WARNING/INDICATOR/CHIME LIST 25</p> <p style="padding-left: 20px;">WARNING/INDICATOR/CHIME LIST : Warning/Indicator (On Information Display) 25</p> <p>OPERATION 27</p> <p>VEHICLE-TO-VEHICLE DISTANCE CONTROL MODE FUNCTION 27</p> <p style="padding-left: 20px;">VEHICLE-TO-VEHICLE DISTANCE CONTROL MODE FUNCTION : Switch Name and Function 27</p> <p style="padding-left: 20px;">VEHICLE-TO-VEHICLE DISTANCE CONTROL MODE FUNCTION : Menu Displayed by Pressing Each Switch 27</p> <p>CONVENTIONAL (FIXED SPEED) CRUISE CONTROL MODE FUNCTION 31</p> <p style="padding-left: 20px;">CONVENTIONAL (FIXED SPEED) CRUISE CONTROL MODE FUNCTION : Switch Name and Function 31</p> <p style="padding-left: 20px;">CONVENTIONAL (FIXED SPEED) CRUISE CONTROL MODE FUNCTION : Menu Displayed by Pressing Each Switch 31</p> <p>HANDLING PRECAUTION 34</p> <p style="padding-left: 20px;">Precautions for Vehicle-to-Vehicle Distance Control Mode 34</p> <p style="padding-left: 20px;">Precautions for Conventional (Fixed Speed) Cruise Control Mode 36</p> <p>DIAGNOSIS SYSTEM (ADAS CONTROL UNIT) 37</p> <p style="padding-left: 20px;">On Board Diagnosis Function (With ICC) 37</p> <p style="padding-left: 20px;">CONSULT Function (ICC/ADAS) 39</p>
---	---

CCS

DIAGNOSIS SYSTEM (ADAS CONTROL UNIT 2)	54	TYPE 2	136
CONSULT Function (ICC/ADAS 2)	54	TYPE 2 : Description	136
DIAGNOSIS SYSTEM (ICC SENSOR)	61	TYPE 2 : Required Tools	137
CONSULT Function (LASER/RADAR)	61	TYPE 2 : Preparation	138
DIAGNOSIS SYSTEM (ACCELERATOR PEDAL ACTUATOR)	63	TYPE 2 : Vehicle Set Up	138
CONSULT Function (ACCELERATOR PEDAL ACT)	63	TYPE 2 : Setting The ICC Target Board	141
ECU DIAGNOSIS INFORMATION	65	TYPE 2 : ICC Sensor Adjustment	142
ADAS CONTROL UNIT	65	ACTION TEST	144
Reference Value	65	Description	144
Fail-safe (ADAS Control Unit)	72	Work Procedure (Vehicle-To-Vehicle Distance Control Mode)	144
DTC Inspection Priority Chart	73	Work Procedure [Conventional (Fixed Speed) Cruise Control Mode]	147
DTC Index	75	DTC/CIRCUIT DIAGNOSIS	150
ADAS CONTROL UNIT 2	78	C1A00 CONTROL UNIT	150
Reference Value	78	DTC Description	150
Fail-safe (ADAS Control Unit 2)	84	Diagnosis Procedure	150
DTC Inspection Priority Chart	84	C1A01 POWER SUPPLY CIRCUIT 1, C1A02 POWER SUPPLY CIRCUIT 2	151
DTC Index	85	DTC Description	151
ICC SENSOR	87	Diagnosis Procedure	151
Reference Value	87	C1A12 RADAR OFF-CENTER	152
Fail-safe (ICC Sensor)	88	DTC Description	152
DTC Inspection Priority Chart	88	Diagnosis Procedure	152
DTC Index	88	C1A16 RADAR BLOCKED	153
ACCELERATOR PEDAL ACTUATOR	90	DTC Description	153
Reference Value	90	Diagnosis Procedure	153
Fail-safe (Accelerator Pedal Actuator)	91	C1A21 UNIT HIGH TEMP	155
DTC Inspection Priority Chart	91	DTC Description	155
DTC Index	91	Diagnosis Procedure	155
WIRING DIAGRAM	93	C1A23 UNIT LOW TEMP	156
INTELLIGENT CRUISE CONTROL	93	DTC Description	156
Wiring Diagram	93	Diagnosis Procedure	156
BASIC INSPECTION	129	C1A39 STEERING ANGLE SENSOR	157
DIAGNOSIS AND REPAIR WORK FLOW	129	DTC Description	157
Work Flow	129	Diagnosis Procedure	157
ADDITIONAL SERVICE WHEN REPLACING ICC SENSOR	131	C1A50 ADAS CONTROL UNIT	158
Description	131	DTC Description	158
Work Procedure	131	Diagnosis Procedure	158
ICC SENSOR ALIGNMENT	132	U0104 ADAS CAN 1	159
Application Notice	132	DTC Description	159
TYPE 1	132	Diagnosis Procedure	159
TYPE 1 : Description	132	U0121 VDC CAN 2	161
TYPE 1 : Work Procedure (Preparation)	132	DTC Description	161
TYPE 1 : Work Procedure (Setting The ICC Target Board)	133	Diagnosis Procedure	161
TYPE 1 : Work Procedure (Radar Alignment)	135	U0126 STRG SEN CAN 1	163
		DTC Description	163
		Diagnosis Procedure	163

U0405 ADAS CAN 2	165	THE SYSTEM DOES NOT DETECT THE VE-	
DTC Description	165	HICLE AHEAD AT ALL	185
Diagnosis Procedure	165	Description	185
U0415 VDC CAN 1	167	Diagnosis Procedure	185
DTC Description	167	NORMAL OPERATING CONDITION	187
Diagnosis Procedure	167	Description	187
U0428 STRG SEN CAN 2	169	REMOVAL AND INSTALLATION	190
DTC Description	169	ICC SENSOR	190
Diagnosis Procedure	169	Exploded View	190
U1000 CAN COMM CIRCUIT	171	Removal and Installation	190
DTC Description	171	ICC STEERING SWITCH	192
Diagnosis Procedure	171	Exploded View	192
U1010 CONTROL UNIT (CAN)	172	ASC D	
DTC Description	172	HOW TO USE THIS MANUAL	193
Diagnosis Procedure	172	HOW TO USE THIS SECTION	193
POWER SUPPLY AND GROUND CIRCUIT ...	173	Information	193
Diagnosis Procedure	173	PRECAUTION	194
SYMPTOM DIAGNOSIS	174	PRECAUTIONS	194
INTELLIGENT CRUISE CONTROL SYSTEM		Precautions for Removing Battery Terminal	194
SYMPTOMS	174	Precaution for Battery Service	194
Symptom Table	174	SYSTEM DESCRIPTION	195
MAIN SWITCH DOES NOT TURN ON, MAIN		COMPONENT PARTS	195
SWITCH DOES NOT TURN OFF	175	Component Parts Location	195
Description	175	ADAS Control Unit	196
Diagnosis Procedure	175	ASC D Steering Switch	196
ICC SYSTEM CANNOT BE SET (MAIN		Brake Pedal Position Switch / Stop Lamp Switch..	196
SWITCH TURNS ON/OFF)	176	Combination Meter	197
Description	176	SYSTEM	198
Diagnosis Procedure	176	AUTOMATIC SPEED CONTROL DEVICE (ASC D) ..	198
ICC STEERING SWITCH (OTHER THAN		AUTOMATIC SPEED CONTROL DEVICE (AS-	
MAIN SWITCH) DOES NOT FUNCTION	178	CD) : System Description	198
Description	178	AUTOMATIC SPEED CONTROL DEVICE (AS-	
Diagnosis Procedure	178	CD) : Fail-safe (ADAS Control Unit)	199
ICC SYSTEM DOES NOT CANCEL WHEN A/		Circuit Diagram	200
T SELECTOR LEVER SETS ON "N"	179	WARNING/INDICATOR/CHIME LIST	200
Description	179	WARNING/INDICATOR/CHIME LIST : Indicator/	
Diagnosis Procedure	179	Information	200
CHIME DOES NOT SOUND	180	OPERATION	201
Description	180	AUTOMATIC SPEED CONTROL DEVICE (ASC D) ..	201
Diagnosis Procedure	180	AUTOMATIC SPEED CONTROL DEVICE (AS-	
DRIVING FORCE IS HUNTING	182	CD) : Switch Name and Function	201
Description	182	AUTOMATIC SPEED CONTROL DEVICE (AS-	
Diagnosis Procedure	182	CD) : Menu Displayed by Pressing Each Switch ..	201
FREQUENTLY CANNOT DETECT THE VEHI-		HANDLING PRECAUTION	203
CLE AHEAD / DETECTION ZONE IS SHORT.	183	Precautions for Automatic Speed Control Device	
Description	183	(ASC D)	203
Diagnosis Procedure	183		

DIAGNOSIS SYSTEM (ADAS CONTROL UNIT)	204	MAIN SWITCH DOES NOT TURN ON, MAIN SWITCH DOES NOT TURN OFF	246
CONSULT Function (ICC/ADAS)	204	Description	246
ECU DIAGNOSIS INFORMATION	219	Diagnosis Procedure	246
ADAS CONTROL UNIT	219	SYSTEM CANNOT BE SET (MAIN SWITCH TURNS ON/OFF)	247
Reference Value	219	Description	247
Fail-safe (ADAS Control Unit)	226	Diagnosis Procedure	247
DTC Inspection Priority Chart	227	STEERING SWITCH (OTHER THAN MAIN SWITCH) DOES NOT FUNCTION	249
DTC Index	229	Description	249
WIRING DIAGRAM	232	Diagnosis Procedure	249
AUTOMATIC SPEED CONTROL DEVICE (ASCD)	232	SYSTEM DOES NOT CANCEL WHEN A/T SELECTOR LEVER SETS ON "N"	250
Wiring Diagram	232	Description	250
BASIC INSPECTION	241	Diagnosis Procedure	250
DIAGNOSIS AND REPAIR WORK FLOW	241	DRIVING FORCE IS HUNTING	251
Work Flow	241	Description	251
ACTION TEST	243	Diagnosis Procedure	251
Description	243	NORMAL OPERATING CONDITION	252
Work Procedure [Automatic Speed Control Device (ASCD)]	243	Description	252
SYMPTOM DIAGNOSIS	245	REMOVAL AND INSTALLATION	253
AUTOMATIC SPEED CONTROL DEVICE (ASCD) SYMPTOMS	245	STEERING SWITCH	253
Symptom Table	245	Exploded View	253

PRECAUTION

PRECAUTIONS

Precaution for Supplemental Restraint System (SRS) "AIR BAG" and "SEAT BELT PRE-TENSIONER"

INFOID:000000013952960

The Supplemental Restraint System such as "AIR BAG" and "SEAT BELT PRE-TENSIONER", used along with a front seat belt, helps to reduce the risk or severity of injury to the driver and front passenger for certain types of collision. This system includes seat belt switch inputs and dual stage front air bag modules. The SRS system uses the seat belt switches to determine the front air bag deployment, and may only deploy one front air bag, depending on the severity of a collision and whether the front occupants are belted or unbelted. Information necessary to service the system safely is included in the "SRS AIR BAG" and "SEAT BELT" of this Service Manual.

WARNING:

Always observe the following items for preventing accidental activation.

- To avoid rendering the SRS inoperative, which could increase the risk of personal injury or death in the event of a collision that would result in air bag inflation, it is recommended that all maintenance and repair be performed by an authorized NISSAN/INFINITI dealer.
- Improper repair, including incorrect removal and installation of the SRS, can lead to personal injury caused by unintentional activation of the system. For removal of Spiral Cable and Air Bag Module, see "SRS AIR BAG".
- Never use electrical test equipment on any circuit related to the SRS unless instructed to in this Service Manual. SRS wiring harnesses can be identified by yellow and/or orange harnesses or harness connectors.

PRECAUTIONS WHEN USING POWER TOOLS (AIR OR ELECTRIC) AND HAMMERS

WARNING:

Always observe the following items for preventing accidental activation.

- When working near the Air Bag Diagnosis Sensor Unit or other Air Bag System sensors with the ignition ON or engine running, never use air or electric power tools or strike near the sensor(s) with a hammer. Heavy vibration could activate the sensor(s) and deploy the air bag(s), possibly causing serious injury.
- When using air or electric power tools or hammers, always switch the ignition OFF, disconnect the battery or batteries, and wait at least 3 minutes before performing any service.

Precautions for Removing Battery Terminal

INFOID:000000013952961

When disconnecting the battery terminal, pay attention to the following.

- Always use a 12V battery as power source.
- Never disconnect battery terminal while engine is running.
- When removing the 12V battery terminal, turn OFF the ignition switch and wait at least 30 seconds.
- For vehicles with the engine listed below, remove the battery terminal after a lapse of the specified time:

BR08DE	: 4 minutes	YD25DDTi	: 2 minutes
D4D engine	: 20 minutes	YS23DDT	: 4 minutes
HRA2DDT	: 12 minutes	YS23DDTT	: 4 minutes
K9K engine	: 4 minutes	ZD30DDTi	: 60 seconds
M9R engine	: 4 minutes	ZD30DDTT	: 60 seconds
R9M engine	: 4 minutes		
V9X engine	: 4 minutes		

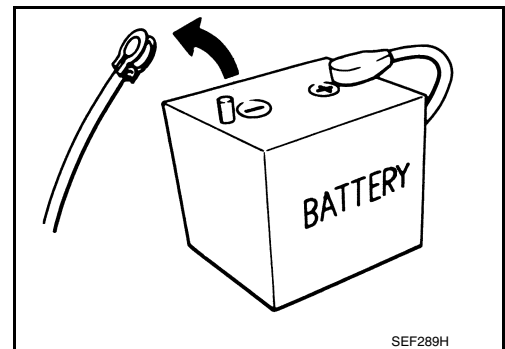

NOTE:

ECU may be active for several tens of seconds after the ignition switch is turned OFF. If the battery terminal is removed before ECU stops, then a DTC detection error or ECU data corruption may occur.

- After high-load driving, if the vehicle is equipped with the V9X engine, turn the ignition switch OFF and wait for at least 15 minutes to remove the battery terminal.

NOTE:

A
B
C
D
E
F
G
H
I
J
K
L
M
N
P

PRECAUTIONS

[ICC]

< PRECAUTION >

- Turbocharger cooling pump may operate in a few minutes after the ignition switch is turned OFF.
- Example of high-load driving
 - Driving for 30 minutes or more at 140 km/h (86 MPH) or more.
 - Driving for 30 minutes or more on a steep slope.
- For vehicles with the 2-batteries, be sure to connect the main battery and the sub battery before turning ON the ignition switch.

NOTE:

If the ignition switch is turned ON with any one of the terminals of main battery and sub battery disconnected, then DTC may be detected.

- After installing the 12V battery, always check "Self Diagnosis Result" of all ECUs and erase DTC.

NOTE:

The removal of 12V battery may cause a DTC detection error.

Precaution for Battery Service

INFOID:000000014271109

Before disconnecting the battery, lower both the driver and passenger windows. This will prevent any interference between the window edge and the vehicle when the door is opened/closed. During normal operation, the window slightly raises and lowers automatically to prevent any window to vehicle interference. The automatic window function will not work with the battery disconnected.

Precautions For Harness Repair

INFOID:000000013711770

ITS communication uses a twisted pair line. Be careful when repairing it.

- Solder the repaired area and wrap tape around the soldered area.

NOTE:

A fray of twisted lines must be within 110 mm (4.33 in).

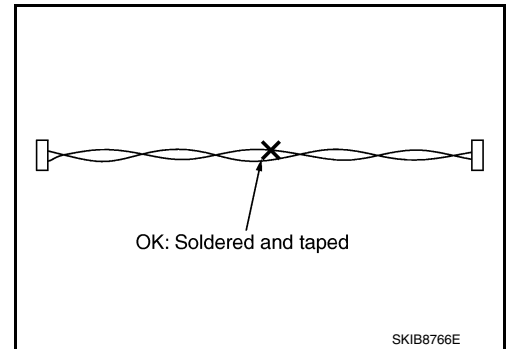

- Bypass connection is never allowed at the repaired area.

NOTE:

Bypass connection may cause ITS communication error. The spliced wire becomes separated and the characteristics of twisted line are lost.

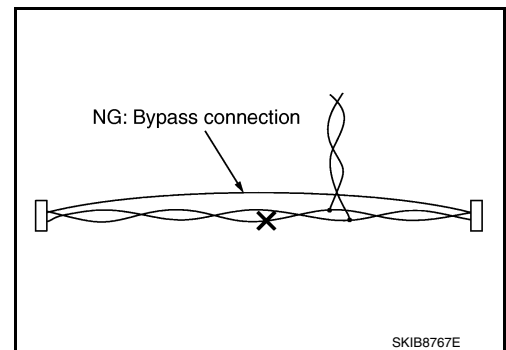

ICC System Service

INFOID:000000013711771

CAUTION:

- Turn the MAIN switch OFF in conditions similar to driving, such as free rollers or a chassis dynamometer.
- Erase DTC when replacing parts of ICC system, then check the operation of ICC system after radar alignment if necessary.

PRECAUTION FOR ICC SENSOR

- Never use the ICC sensor removed from vehicle. Never disassemble or remodel.

PRECAUTIONS

[ICC]

< PRECAUTION >

- Never install a part that the radar irradiation range ① is interfered with.
- If a part interferes with the radar irradiation range, then the following conditions are caused:
 - The condition of ICC sensor becomes equal to an unclean condition, and this makes it difficult to measure the distance between cars.
 - When it is impossible to measure the distance between cars, the following functions stop and DTC is detected.
 - Forward Emergency Braking (FEB)
 - Intelligent Cruise Control (ICC)
 - Distance Control Assist (DCA)
 - Predictive Forward Collision Warning (PFCW)

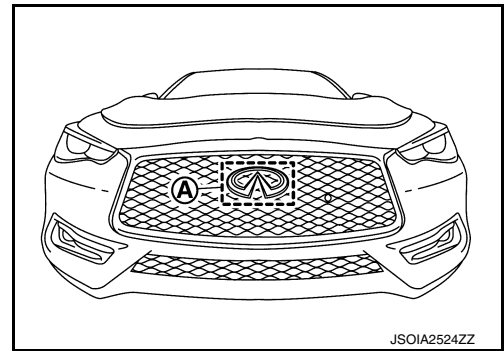

A
B
C
D
E
F
G
H
I
J
K
L
M
N
P

CCS

PREPARATION

< PREPARATION >

[ICC]

PREPARATION

PREPARATION

Special Service Tools

INFOID:000000013711772

Tool number (Kent-Moore No.) Tool name	Description
KV99112700 (—) ICC target board	Uses for radar alignment
— (1-20-2721-1-IF) ICC alignment kit	Uses for radar alignment
— (1-20-2722-1-IF) Wheel adaptor	Uses for radar alignment
— (J-50808) ICC alignment kit attachment board	Uses for radar alignment

NOTE:

For radar alignment, KV99112700 or a set of Kent-Moore No. SST are to be used.

SYSTEM DESCRIPTION

COMPONENT PARTS

Component Parts Location

INFOID:000000013711773

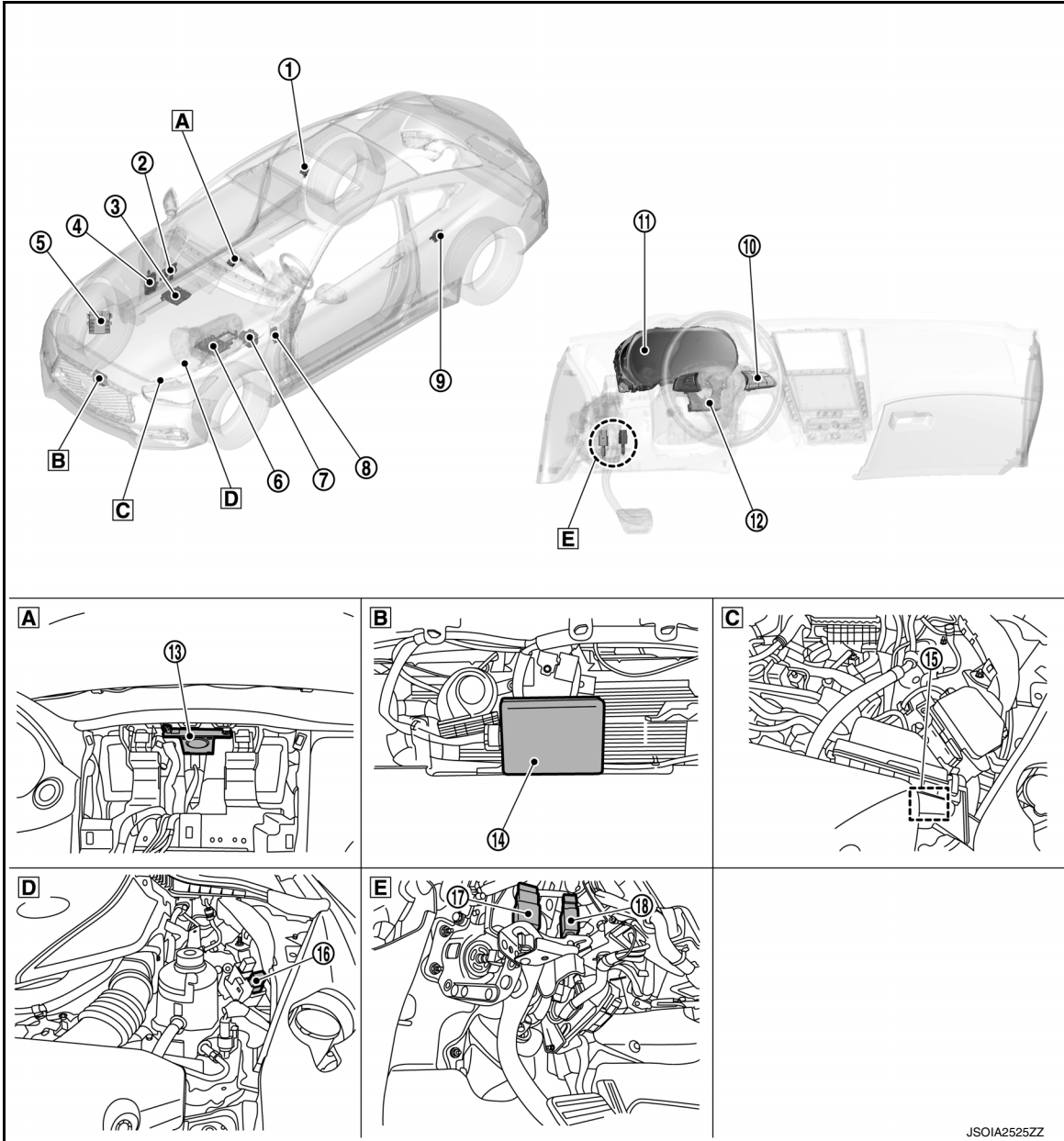

- A** Instrument panel (Center)
- B** Front bumper (Center)
- C** Engine room (LH) (VR30DDTT)
- D** Engine room (LH) (2.0L turbo gasoline engine)
- E** Upper side of brake pedal

A
B
C
D
E
F
G
H
I
J
K
L
M
N
P

CCS

COMPONENT PARTS

< SYSTEM DESCRIPTION >

[ICC]

×: Applicable

No.	Component	Function		Description
		Vehicle-to-vehicle distance control mode	Conventional (fixed speed) cruise control mode	
①	ADAS control unit	×	×	<ul style="list-style-type: none"> Refer to CCS-12, "ADAS Control Unit" Refer to DAS-18, "Component Parts Location" for detailed installation location
②	EMCM	×	×	<ul style="list-style-type: none"> EMCM transmits the brake pedal position switch signal to ADAS control unit via CAN communication Refer to EC4-25, "ENGINE CONTROL SYSTEM : Component Parts Location" for detailed installation location.
③	ECM (2.0L turbo gasoline engine)	×	×	<ul style="list-style-type: none"> ECM transmits the accelerator pedal position signal, ICC brake switch signal, stop lamp switch signal, ICC steering switch etc. to ADAS control unit via CAN communication ECM controls the electric throttle control actuator based on the engine torque demand received from the ADAS control unit via CAN communication Refer to EC4-25, "ENGINE CONTROL SYSTEM : Component Parts Location" for detailed installation location
④	BCM	×		<ul style="list-style-type: none"> Transmits the stop lamp signal to ADAS control unit via CAN communication Refer to BCS-5, "BODY CONTROL SYSTEM : Component Parts Location" for detailed installation location
⑤	ECM (VR30DDTT)	×	×	<ul style="list-style-type: none"> ECM transmits the accelerator pedal position signal, ICC brake switch signal, stop lamp switch signal, ICC steering switch etc. to ADAS control unit via CAN communication ECM controls the electric throttle control actuator based on the engine torque demand received from the ADAS control unit via CAN communication Refer to EC6-23, "Component Parts Location" for detailed installation location
⑥	TCM	×	×	<ul style="list-style-type: none"> TCM transmits the signal related to A/T control to ADAS control unit via CAN communication Refer to TM-14, "A/T CONTROL SYSTEM : Component Parts Location" for detailed installation location
⑦	ABS actuator and electric unit (control unit)	×	×	<ul style="list-style-type: none"> ABS actuator and electric unit (control unit) transmits the vehicle speed signal (wheel speed), stop lamp switch signal and VDC/TCS/ABS system operation condition to ADAS control unit via CAN communication ABS actuator and electric unit (control unit) controls the brake, based on a brake fluid pressure control signal received from the ADAS control unit via chassis control module Refer to BRC-11, "Component Parts Location" for detailed installation location
⑧	Chassis control module	×	×	<ul style="list-style-type: none"> Chassis control module transmits the drive mode signal to ADAS control unit via CAN communication Refer to DAS-666, "Component Parts Location" for detailed installation location

COMPONENT PARTS

< SYSTEM DESCRIPTION >

[ICC]

No.	Component	Function		Description
		Vehicle-to-vehicle distance control mode	Conventional (fixed speed) cruise control mode	
⑨	ADAS control unit 2	×	×	Refer to CCS-12, "ADAS Control Unit 2"
⑩	ICC steering switch	×	×	<ul style="list-style-type: none"> Description: Refer to CCS-12, "ICC Steering Switch" Switch name and function: CCS-27, "VEHICLE-TO-VEHICLE DISTANCE CONTROL MODE FUNCTION : Switch Name and Function" (Vehicle to vehicle distance control mode) Switch name and function: CCS-31, "CONVENTIONAL (FIXED SPEED) CRUISE CONTROL MODE FUNCTION : Switch Name and Function" (Conventional cruise control mode)
⑪	Combination meter	×	×	<p>Performs the following operations using the signals received from the ADAS control unit via the CAN communication</p> <ul style="list-style-type: none"> Description: Refer to CCS-13, "Combination Meter" System display and warning: CCS-27, "VEHICLE-TO-VEHICLE DISTANCE CONTROL MODE FUNCTION : Menu Displayed by Pressing Each Switch" (Vehicle to vehicle distance control mode) System display and warning: CCS-31, "CONVENTIONAL (FIXED SPEED) CRUISE CONTROL MODE FUNCTION : Menu Displayed by Pressing Each Switch" (Conventional cruise control mode) Refer to MWI-8, "METER SYSTEM : Component Parts Location" for detailed installation location
⑫	Steering angle sensor	×		Measures the rotation amount, rotation speed, and rotation direction of steering wheel, and then transmits them to ADAS control unit via CAN communication
⑬	Driver assistance buzzer	×	×	Refer to CCS-14, "Driver Assistance Buzzer"
⑭	ICC sensor	×	×	Refer to CCS-12, "ICC Sensor"
⑮	ICC brake hold relay (VR30DDTT)	×		Refer to CCS-13, "ICC Brake Hold Relay"
⑯	ICC brake hold relay (2.0L turbo gasoline engine)			
⑰	Stop lamp switch	×	×	Refer to CCS-13, "Brake Pedal Position Switch / Stop Lamp Switch"
⑱	Brake pedal position switch	×	×	

A
B
C
D
E
F
G
H
I
J
K
L
M
N
P

CCS

ADAS Control Unit

INFOID:000000013965385

- ADAS control unit is installed at rear side panel LH.
- Communicates with each control unit via CAN communication/ITS communication/Chassis communication.
- ADAS control unit included gateway function, and necessary for system control signals are transmitted to each control unit between CAN communication and ITS communication by the ADAS control unit.
- ADAS control unit controls the each system, based on ITS communication signal, CAN communication signal, and chassis communication signal from each control unit.

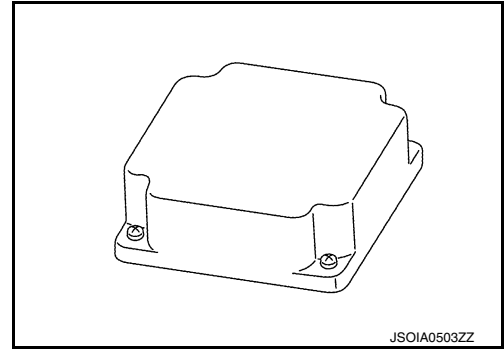

ADAS Control Unit 2

INFOID:000000013965386

- ADAS control unit 2 is installed at rear side panel RH.
- Communicates with each control unit via CAN communication (via ADAS control unit)/ITS communication/Chassis communication.
- ADAS control unit controls the each system, based on ITS communication signal, CAN communication signal (via ADAS control unit), and chassis communication signal from each control unit.

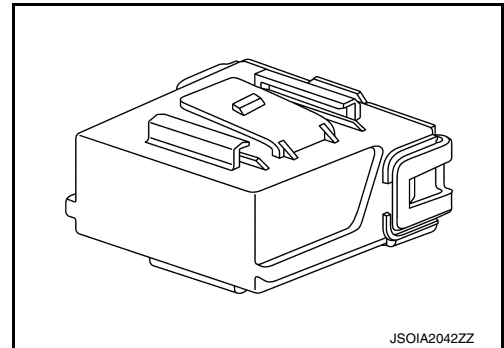

ICC Sensor

INFOID:000000013711775

- ICC sensor is installed reverse side of front emblem and detects a vehicle ahead by using millimeter waves.
- ICC sensor detects radar reflected from a vehicle ahead by irradiating radar forward and calculates a distance from the vehicle ahead and relative speed, based on the detected signal.
- ICC sensor transmits the presence/absence of vehicle ahead and the distance from the vehicle to ADAS control unit via ITS communication.

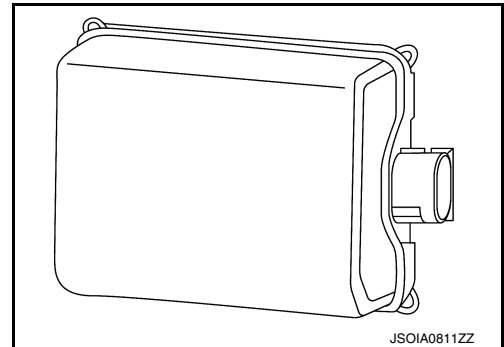

ICC Steering Switch

INFOID:000000013711776

- ICC steering switch is installed to the steering wheel and allows the driver to operate the ICC system by using this switch.
- ICC steering switch allows the ON/OFF of the Intelligent Cruise Control and the settings of a vehicle speed and distance between vehicles.
- ICC steering switch signal is transmitted to ECM. ECM transmits the signal to the ADAS control unit via CAN communication. (VR30DDTT)
- ICC steering switch signal is transmitted to ADAS control unit. ADAS control unit transmits the signal to the ADAS control unit via CAN communication. (2.0 TURBO GASOLINE ENGINE)

COMPONENT PARTS

< SYSTEM DESCRIPTION >

[ICC]

Brake Pedal Position Switch / Stop Lamp Switch

INFOID:000000013711777

- Brake pedal position switch is installed at the upper part of the brake pedal and detects a brake operation performed by the driver.

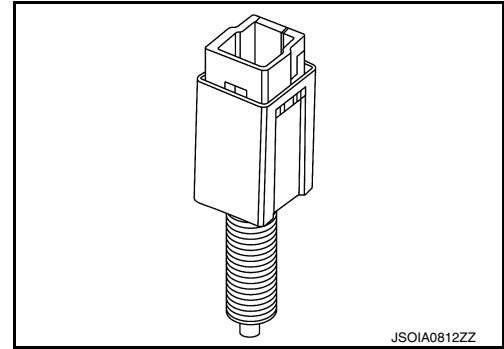

- Brake pedal position switch is turned OFF when depressing the brake pedal.
- Brake pedal position switch signal is input to ECM. Brake pedal position switch signal is transmitted from ECM to ADAS control unit via CAN communication. (VR30DDTT)
- Brake pedal position switch signal is input to EMCM. Brake pedal position switch signal is transmitted from EMCM to ADAS control unit via CAN communication. (2.0 TURBO GASOLINE ENGINE)

- Stop lamp switch is installed at the upper part of the brake pedal and detects a brake operation performed by the driver.
- Stop lamp switch is turned ON, when depressing the brake pedal.
- Stop lamp switch signal is input to ECM and ABS actuator and electric unit (control unit). Stop lamp switch signals are transmitted from ECM and ABS actuator and electric unit (control unit) to ADAS control unit via CAN communication. (VR30DDTT)
- Stop lamp switch signal is input to BCM and ABS actuator and electric unit (control unit). Stop lamp switch signals are transmitted from BCM and ABS actuator and electric unit (control unit) to ADAS control unit via CAN communication. (2.0 TURBO GASOLINE ENGINE)

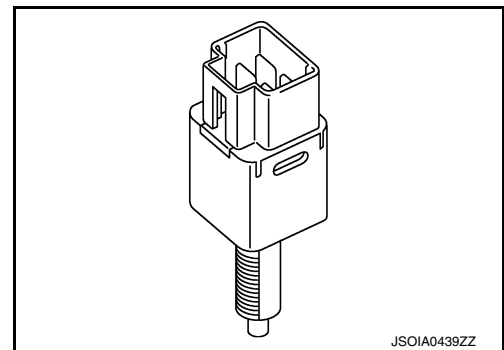

ICC Brake Hold Relay

INFOID:000000013711778

- ICC brake hold relay is installed in the engine room (right side).
- When the brake is activated by the system, the ICC brake hold relay turns ON the stop lamp by bypassing the circuit of the stop lamp, according to a signal transmitted from the ADAS control unit.

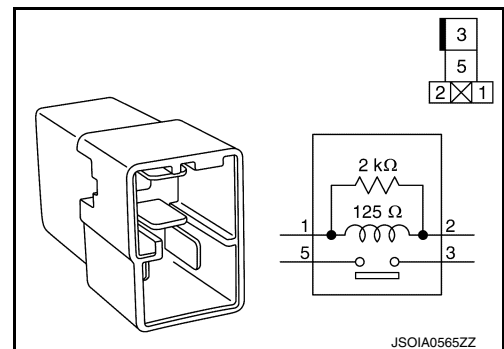

Combination Meter

INFOID:000000013711779

- Receives meter display signal from ADAS control unit via CAN communication.
- Displays the system status according to a signal received from the ADAS control unit.

A
B
C
D
E
F
G
H
I
J
K
L
M
N
P

CCS

COMPONENT PARTS

< SYSTEM DESCRIPTION >

[ICC]

Driver Assistance Buzzer

INFOID:000000013711781

- Driver assistance buzzer is installed at the behind the display control unit.
- When a warning buzzer signal is received from the ADAS control unit 2, the driver assistance buzzer sounds a buzzer.

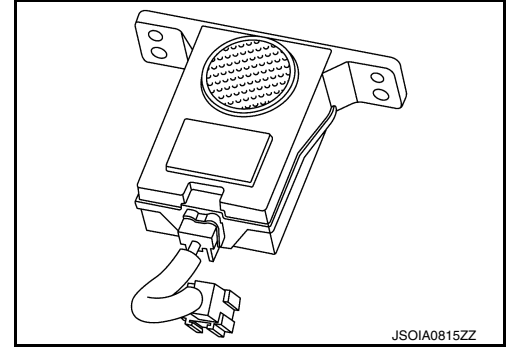

SYSTEM

System Description

INFOID:000000013711782

SYSTEM DIAGRAM

VR30DDTT

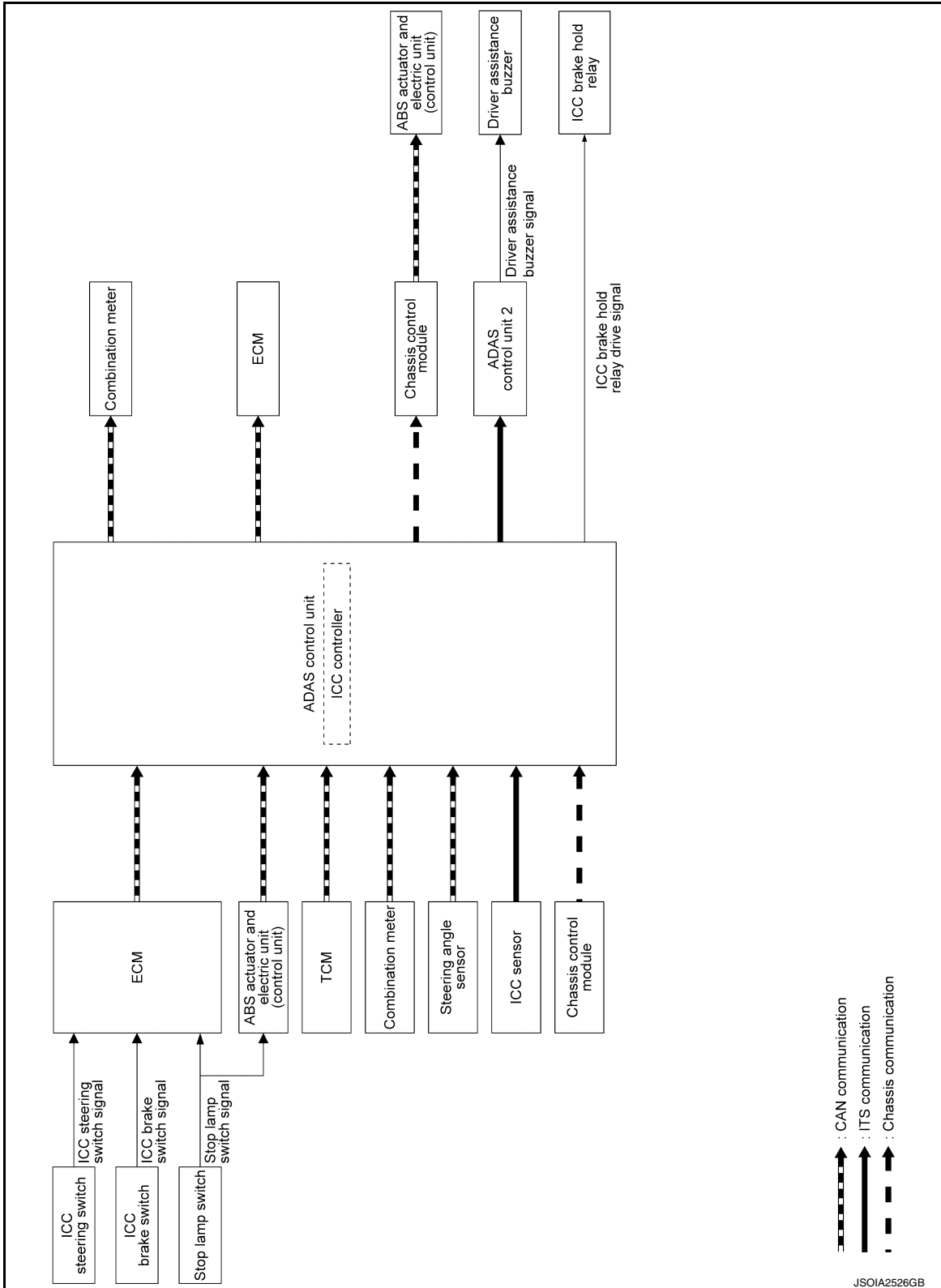

A
B
C
D
E
F
G
H
I
J
K
L
M
N
P

CCS

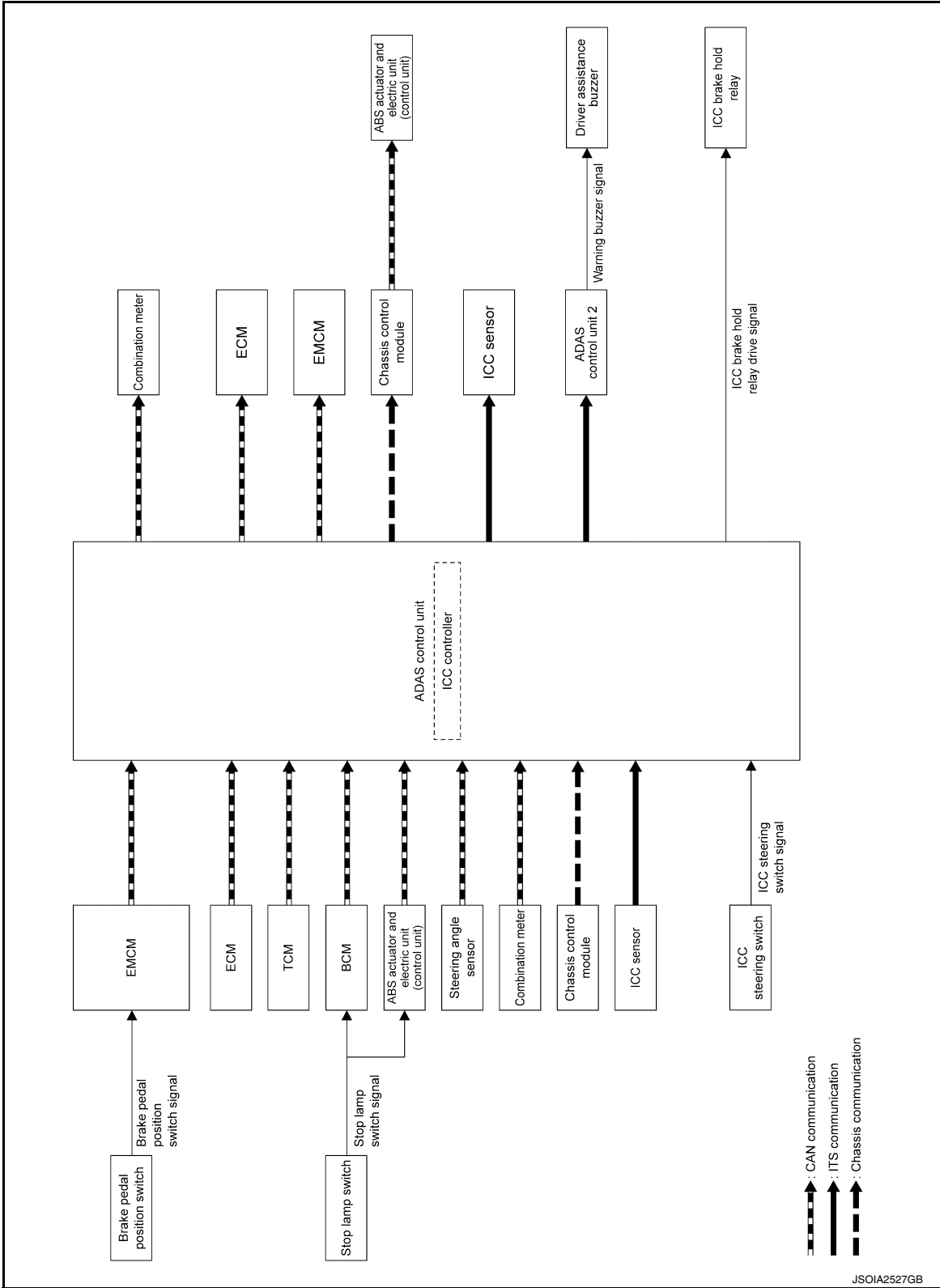

NOTE:

TCM is connected to drivetrain CAN communication and transmits a CAN communication signal to ADAS control unit via ECM

ADAS CONTROL UNIT INPUT/OUTPUT SIGNAL ITEM

Input Signal Item

SYSTEM

< SYSTEM DESCRIPTION >

[ICC]

Transmit unit	Signal name		Description		
ECM	CAN communication	Closed throttle position signal		Receives idle position state (ON/OFF)	
		Accelerator pedal position signal		Receives accelerator pedal position (angle)	
		ICC prohibition signal		Receives an operable/inoperable state of the ICC system	
		Engine speed signal		Receives engine speed	
		ICC steering switch signal*1	MAIN switch signal		Receives the operational state of the ICC steering switch
			SET/COAST switch signal		
			CANCEL switch signal		
			RESUME/ACCELERATE switch signal		
			DISTANCE switch signal		
Stop lamp switch signal*1		Receives an operational state of the brake pedal			
Brake pedal position switch signal*1		Receives an operational state of the brake pedal			
EMCM*2	CAN communication	Brake pedal position switch signal		Receives an operational state of the brake pedal	
TCM (Via ECM)*2	CAN communication	Input speed signal		Receives the number of revolutions of input shaft	
		Current gear position signal		Receives a current gear position	
		Shift position signal		Receives a selector lever position	
		Output shaft revolution signal		Receives the number of revolutions of output shaft	
ABS actuator and electric unit (control unit)	CAN communication	ABS malfunction signal		Receives a malfunction state of ABS	
		ABS operation signal		Receives an operational state of ABS	
		ABS warning lamp signal		Receives an ON/OFF state of ABS warning lamp	
		TCS malfunction signal		Receives a malfunction state of TCS	
		TCS operation signal		Receives an operational state of TCS	
		VDC OFF switch signal		Receives an ON/OFF state of VDC	
		VDC malfunction signal		Receives a malfunction state of VDC	
		VDC operation signal		Receives an operational state of VDC	
		Vehicle speed signal (ABS)		Receives wheel speeds of four wheels	
		Stop lamp switch signal		Receives an operational state of the brake pedal	
Yaw rate signal		Receives yaw rate acting on the vehicle			
Combination meter	CAN communication	Parking brake switch signal		Receives an operational state of the parking brake	
BCM*2	CAN communication	Stop lamp switch signal		Receives an operational state of the brake pedal	
Steering angle sensor	CAN communication	Steering angle sensor malfunction signal		Receives a malfunction state of steering angle sensor	
		Steering angle sensor signal		Receives the number of revolutions, turning direction of the steering wheel	
		Steering angle speed signal		Receives the turning angle speed of the steering wheel	
Chassis control module	Chassis communication	Drive mode signal	Snow mode	Receives an operational state of the snow mode	

SYSTEM

< SYSTEM DESCRIPTION >

[ICC]

Transmit unit	Signal name		Description
ICC sensor	ITS communication	ICC sensor signal	Receives detection results, such as the presence or absence of a leading vehicle and distance from the vehicle
ICC steering switch*2	ICC steering switch signal		Receives the operational state of the ICC steering switch

*1: VR30DDTT ENGINE

*2: 2.0 TURBO GASOLINE ENGINE

Output Signal Item

Reception unit	Signal name		Description
ECM	CAN communication	ICC operation signal	Transmits an ICC operation signal necessary for intelligent cruise control
ABS actuator and electric unit (control unit)	CAN communication	Brake fluid pressure control signal	Transmits a brake fluid pressure control signal to activate the brake via chassis control module
Combination meter	CAN communication	Meter display signal	Vehicle ahead detection indicator signal
			Set vehicle speed indicator signal
			Set distance indicator signal
			SET switch indicator signal
			MAIN switch indicator signal
		ICC malfunction signal	Transmits an ICC malfunction signal to turn ON the ICC system malfunction
ICC sensor	ITS communication	Vehicle speed signal	Transmits a vehicle speed calculated by the ADAS control unit
ADAS control unit 2	ITS communication	Warning buzzer signal	Transmits a warning buzzer signal to turn ON the buzzer
ICC brake hold relay	ICC brake hold relay drive signal		Activates the brake hold relay and turns ON the stop lamp

DESCRIPTION

Intelligent Cruise Control

The Intelligent Cruise Control (ICC) system maintains a selected distance from the vehicle ahead within set speeds.

The driver can select the set speeds.

The vehicle travels at a set speed when the road ahead is clear.

The ICC system can be set to one of two cruise control modes:

CAUTION:

Never set the cruise speed exceeding the posted speed limit.

Vehicle-to-vehicle Distance Control Mode

For maintaining a selected distance between own vehicle and the vehicle in front of own vehicle up to the preset speed. Refer to [CCS-22, "VEHICLE-TO-VEHICLE DISTANCE CONTROL MODE FUNCTION : System Description"](#).

Conventional (Fixed Speed) Cruise Control Mode

For cruising at a preset speed. Refer to [CCS-24, "CONVENTIONAL \(FIXED SPEED\) CRUISE CONTROL MODE FUNCTION : System Description"](#).

NOTE:

In the Conventional (Fixed Speed) Cruise Control Mode, a warning chime will not sound to warn driver if own vehicle are too close to the vehicle ahead.

WARNING:

SYSTEM

< SYSTEM DESCRIPTION >

[ICC]

Always drive carefully and attentively when using either cruise control mode. To avoid serious injury or death, do not rely on the system to prevent accidents or to control the vehicle's speed in emergency situations. Do not use cruise control except in appropriate road and traffic conditions.

A

Distance Control Assist (DCA) System

DCA share the systems and components with ICC system. Refer to [DAS-369, "DCA : System Description"](#).

B

Predictive Forward Collision Warning (PFCW) System

PFCW share the systems and components with ICC system. Refer to [DAS-374, "PFCW : System Description"](#).

C

Forward Emergency Brake (FEB) System

FEB system share the systems and components with ICC system. Refer to [BRC-216, "System Description"](#).

D

E

F

G

H

I

J

K

L

M

N

CCS

P

SYSTEM

< SYSTEM DESCRIPTION >

[ICC]

Circuit Diagram

INFOID:000000013711783

VR30DDTT

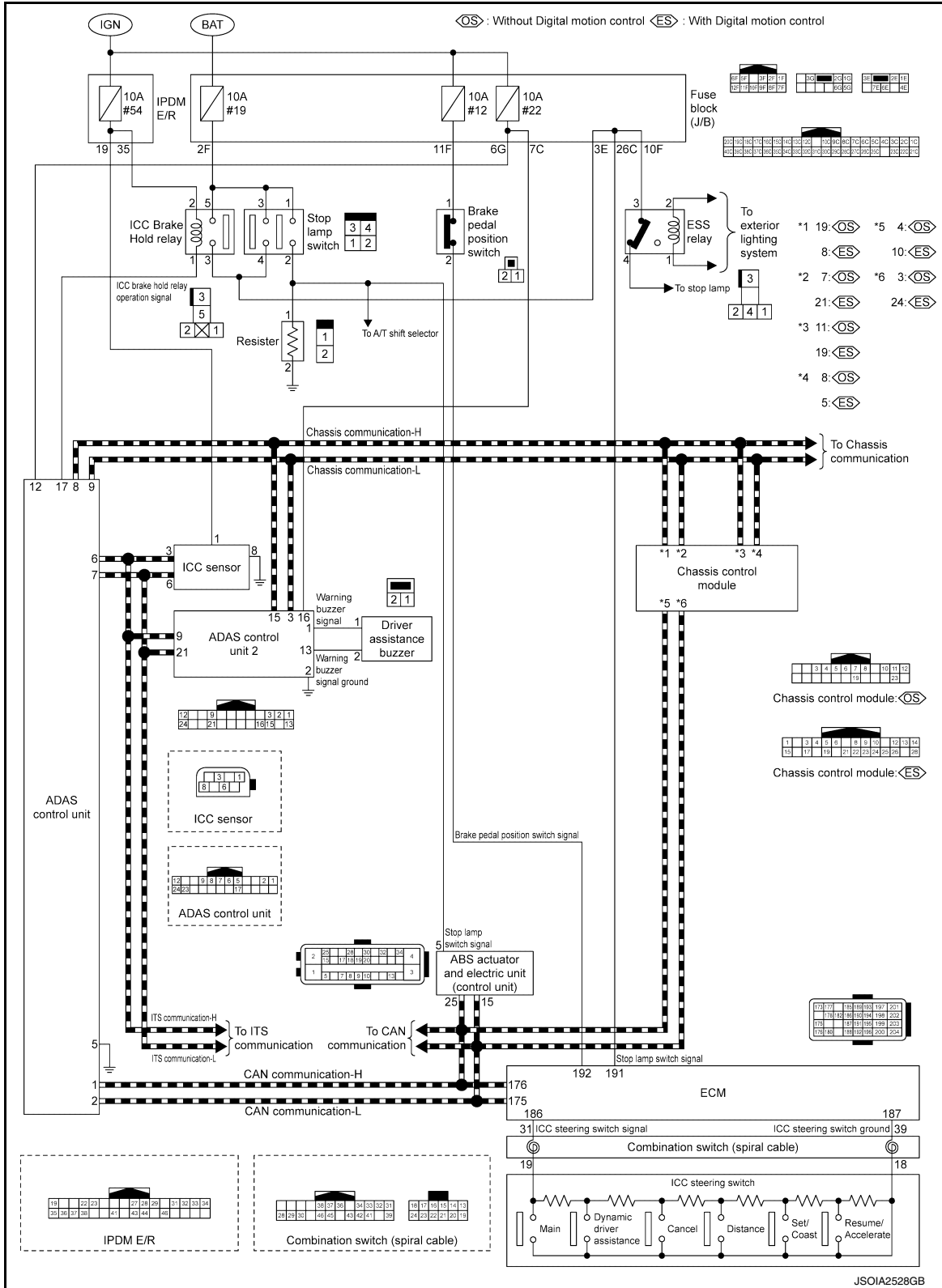

< SYSTEM DESCRIPTION >

2.0L TURBO GASOLINE ENGINE

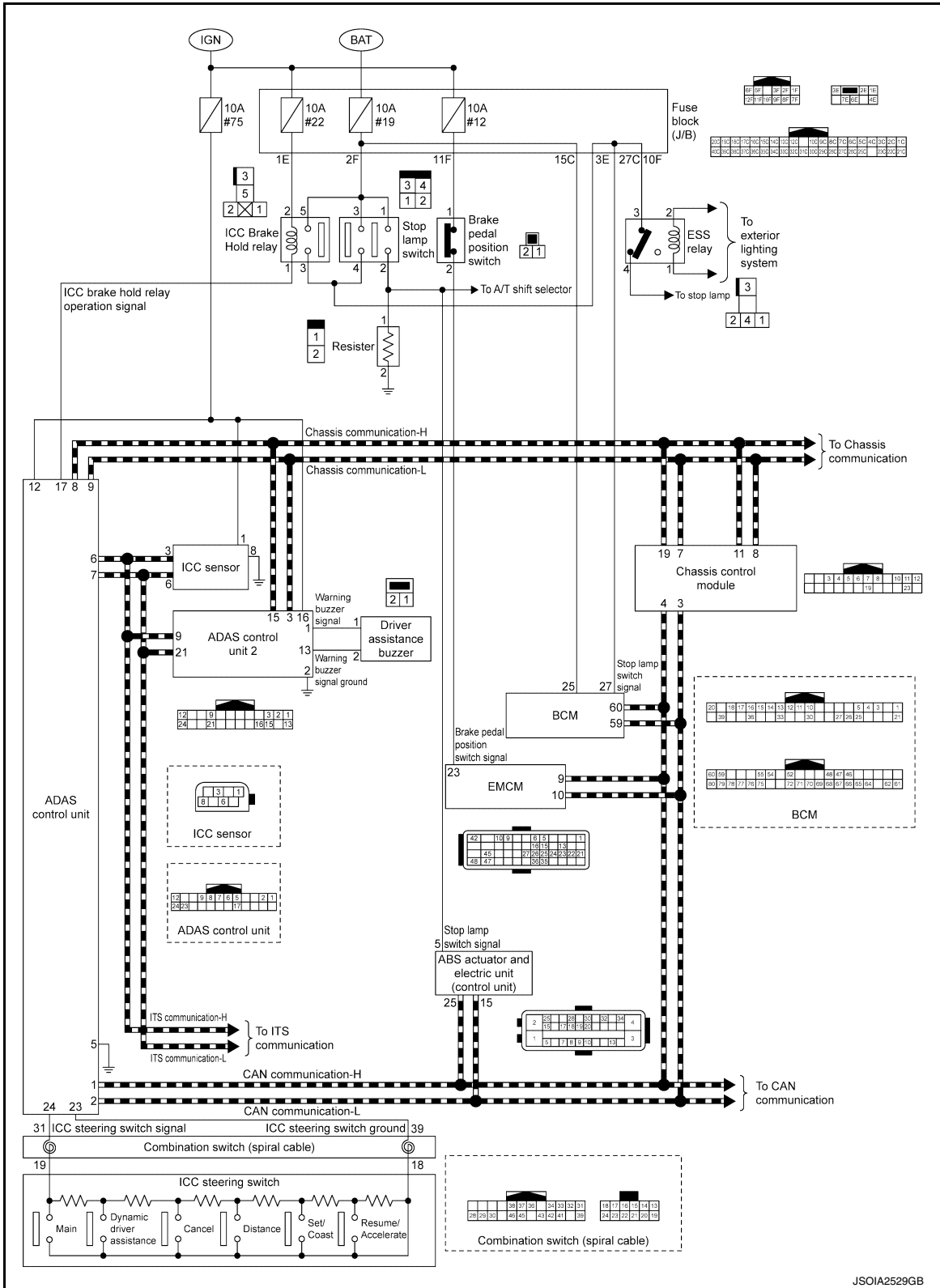

Fail-safe (ADAS Control Unit)

INFOID:0000000113965366

If a malfunction occurs in each system, ADAS control unit cancels each control, sounds a beep, and turns ON the warning or indicator lamp.

SYSTEM

< SYSTEM DESCRIPTION >

[ICC]

System	Buzzer	Warning lamp/Warning display	Description
Vehicle-to-vehicle distance control mode	High-pitched tone	ICC system warning	Cancel
Conventional (fixed speed) cruise control mode	High-pitched tone	ICC system warning	Cancel
Forward Emergency Braking (FEB)	High-pitched tone	<ul style="list-style-type: none">FEB warning lampWarning systems indicator (Forward position: Yellow)	Cancel
Predictive Forward Collision Warning (PFCW)	High-pitched tone	Warning systems indicator (Forward position: Yellow)	Cancel
Distance Control Assist (DCA)	High-pitched tone	Warning systems indicator (Forward position: Yellow)	Cancel
Blind Spot Warning (BSW)	—	Warning systems indicator (Blind spot position: Yellow)	Cancel
Back-up Collision Intervention (BCI)	High-pitched tone	BCI system warning	Cancel

Fail-safe (ADAS Control Unit 2)

INFOID:000000013965367

If a malfunction occurs in each system, ADAS control unit 2 cancels each control, sounds a beep, and turns ON the warning or indicator lamp.

System	Buzzer	Warning lamp/Warning display	Description
Lane Departure Warning (LDW)	—	Warning systems indicator (Lane position: Yellow)	Cancel
Lane Departure Prevention (LDP)	Low-pitched tone	Warning systems indicator (Lane position: Yellow)	Cancel
Blind Spot Intervention	Low-pitched tone	Warning systems indicator (Blind spot position: Yellow)	Cancel

Fail-safe (ICC Sensor)

INFOID:000000013711785

If a malfunction occurs in the ICC sensor, ADAS control unit cancels control, sounds a beep, and turns ON the ICC system warning in the information display.

Fail-safe (Accelerator Pedal Actuator)

INFOID:000000013965373

If a malfunction occurs in the accelerator pedal actuator, ADAS control unit cancels following systems.

- Vehicle-to-vehicle distance control mode
- Distance Control Assist (DCA)
- Forward Emergency Braking (FEB)
- Back-up Collision Intervention (BCI)

VEHICLE-TO-VEHICLE DISTANCE CONTROL MODE FUNCTION

VEHICLE-TO-VEHICLE DISTANCE CONTROL MODE FUNCTION : System Description

INFOID:000000013711786

FUNCTION DESCRIPTION

In the vehicle-to-vehicle distance control mode, the Intelligent Cruise Control (ICC) system automatically maintains a selected distance from the vehicle traveling in front of own vehicle according to that vehicle's speed (up to the set speed), or at the set speed when the road ahead is clear.

SYSTEM

< SYSTEM DESCRIPTION >

[ICC]

With ICC system, the driver can maintain the same speed as other vehicles without the constant need to adjust the set speed as driver would with a normal cruise control system.

The following items are controlled in the vehicle-to-vehicle distance control mode

- When there are no vehicles traveling ahead, the vehicle-to-vehicle distance control mode maintains the speed set by the driver. The selectable speed ranges are as follows:
 - Between approximately 32 and 144 km/h (20 and 90 MPH).
- When there is a vehicle traveling ahead, the vehicle-to-vehicle distance control mode adjusts the speed to maintain the distance, selected by driver, from a vehicle ahead. The adjusting speed range is up to the set speed.
- When the vehicle traveling ahead has moved out from its lane of travel, the vehicle-to-vehicle distance control mode accelerates and maintains vehicle speed up to the set speed.

CAUTION:

- **If the vehicle ahead comes to stop, the vehicle decelerates to a standstill within the limitations of the system. The system will cancel once it judges that the vehicle has come to a standstill and sound a warning chime.**
- **To prevent the vehicle from moving, the driver must depress the brake pedal.**

NOTE:

When the accelerator pedal is depressed, the brake operation and the warning are not performed by the ICC system.

OPERATION DESCRIPTION

Quickly push (less than 1.5 seconds) and release the MAIN switch ON.

The MAIN switch indicator, set distance indicator, own vehicle indicator, and set vehicle speed indicator come on and ICC system is set to a standby state.

ADAS control unit performs the control as per the following:

Constant speed	Comparing the set vehicle speed with the current vehicle speed, transmit the command to ECM via CAN communication to reach the set vehicle speed, and controls the electric throttle control actuator.
Deceleration	When a vehicle ahead (slower than driver set vehicle speed) appears or when a vehicle ahead slows down, the system controls the electric throttle control actuator into the close direction and decelerates the vehicle. If greater deceleration is necessary, the system transmits the brake fluid pressure control signal to the ABS actuator and electric unit (control unit) via chassis control module and operates the brake.
Following	The system controls electric throttle control actuator and the brake fluid pressure to keep the proper distance between the vehicles according to the vehicle speed change of the vehicle ahead.
Acceleration	When a vehicle ahead is not detected because of it changes lanes or own vehicle changes lanes during the following driving, the system controls the electric throttle control actuator in the open direction and accelerates the vehicle to the set vehicle speed slowly.

Set Condition

Under a standby state, pushing down the SET/COAST switch will start system control.

- When vehicle speed is between approximately 32 km/h and 144 km/h (20 MPH and 90 MPH).
- When vehicle speed is below approximately 32 km/h (20 MPH) if the vehicle ahead is detected. The set vehicle speed becomes 32 km/h (20 MPH).

If the system is canceled by conditions 1–10 below, the system will resume control at the last set cruising speed by pushing up the RESUME/ACCELERATE switch.

NOTE:

- When the SET/COAST switch is pushed under the following conditions, the system cannot be set and the set vehicle speed indicator will blink for approximately 2 seconds.

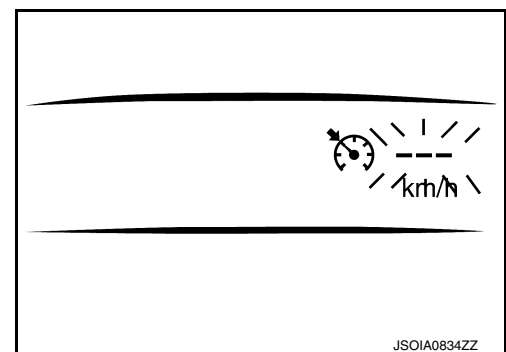

- When traveling below 32 km/h (20 MPH) and the vehicle ahead is not detected.
- When the selector lever is not in the “D” position or manual mode.
- When the parking brakes are applied.

< SYSTEM DESCRIPTION >

- When the brakes are operated by the driver.
- When the SET/COAST switch is pushed under the following conditions, the system cannot be set.
- When the drive mode select switch is in SNOW position. (To use the ICC system, turn OFF the snow mode, push the MAIN switch to turn OFF the ICC system and reset the ICC system by pushing the MAIN switch again.)
- When the VDC is OFF. (To use the ICC system, turn ON the VDC system, push the MAIN switch to turn OFF the ICC system and reset the ICC system by pushing the MAIN switch again.)
- When ABS or VDC (including the TCS) operates.
- When the wheel is slipping. (To use the ICC system, make sure the wheels are no longer spinning, push the MAIN switch to turn OFF the ICC system and reset the ICC system by pushing the MAIN switch again.)

Cancel Conditions

1. When CANCEL switch is pressed.
2. When brake pedal is depressed.
3. When the vehicle ahead is not detected below the speed of 24 km/h (15 MPH).
4. When the selector lever is not in the "D" position or manual mode.
5. When the parking brakes are applied.
6. When the system judges the vehicle is at standstill.
7. When the drive mode select switch is in SNOW position.
8. When ABS or VDC (including the TCS) operates.
9. When a wheel slips.
10. When the VDC is turned OFF.
11. When the MAIN switch is turned OFF.
12. When the system malfunction occurs.

CONVENTIONAL (FIXED SPEED) CRUISE CONTROL MODE FUNCTION

CONVENTIONAL (FIXED SPEED) CRUISE CONTROL MODE FUNCTION : System Description

INFOID:000000013711787

FUNCTION DESCRIPTION

This mode allows driving at a speed between 40 to 144 km/h (25 to 90 MPH) without keeping foot on the accelerator pedal.

NOTE:

In the conventional (fixed speed) cruise control mode, a warning chime does not sound to warn driver if own vehicle are too close to the vehicle ahead, as neither the presence of the vehicle ahead nor the vehicle-to-vehicle distance is detected.

OPERATION DESCRIPTION

To turn ON the conventional (fixed speed) cruise control mode, push and hold the MAIN switch for longer than approximately 1.5 seconds when ICC system is OFF.

When pushing the MAIN switch ON, the ICC system display and the MAIN switch indicator are displayed on the information display.

After hold the MAIN switch ON for longer than approximately 1.5 seconds, the ICC system display goes out. The MAIN switch indicator stays lit and brings the system to standby state.

NOTE:

- To turn on the vehicle-to-vehicle distance control mode again, turn OFF the system and quickly push (less than 1.5 seconds) the MAIN switch.
- When the DCA system is ON, the conventional (fixed speed) cruise control mode cannot be turned on even though the MAIN switch is pushed and held.
- To turn ON the conventional (fixed speed) cruise control mode, turn OFF the DCA system. Refer to [DAS-369, "DCA : System Description"](#).

ADAS control unit performs the control as per the following:

Constant speed	Comparing the set vehicle speed with the current vehicle speed, transmits the command to ECM via CAN communication to reach the set vehicle speed, and controls electronic throttle control actuator.
----------------	---

Set Condition

When the system is under a standby state and the vehicle speed is between approximately 40 km/h (25 MPH) and 144 km/h (90 MPH), pushing the SET/COAST switch will start system control. If the system is canceled by conditions 1–7 below, the system will resume control at the last set cruising speed by pushing the RESUME/ACCELERATE switch.

SYSTEM

[ICC]

< SYSTEM DESCRIPTION >

Cancel conditions

1. When CANCEL switch is pressed.
2. When brake pedal depressed.
3. When the vehicle slows down more than 13 km/h (8 MPH) below the set speed.
4. When the selector lever is not in the "D" position or manual mode.
5. When the parking brakes are applied.
6. When VDC (including the TCS) operates.
7. When a wheel slips.
8. When the MAIN switch is turned OFF.
9. When the system malfunction occurs.

WARNING/INDICATOR/CHIME LIST

WARNING/INDICATOR/CHIME LIST : Warning/Indicator (On Information Display)

INFOID:000000013711788

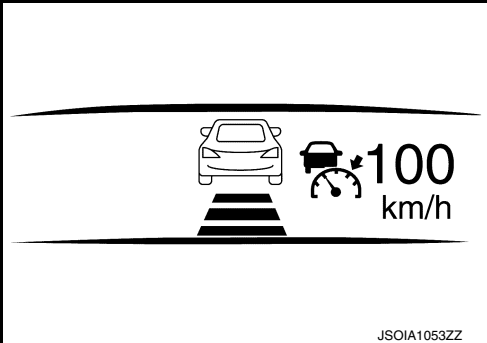
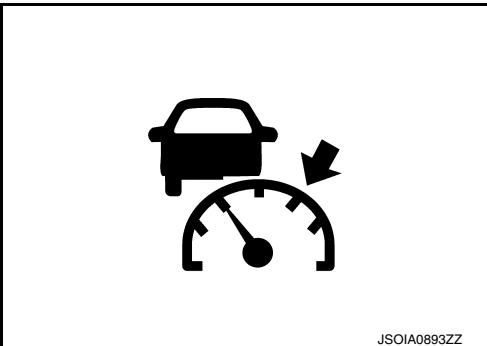
Name	Design	Function
ICC system display (Vehicle-to-vehicle distance control mode)	 <p style="text-align: right; font-size: small;">JSOIA1053ZZ</p>	<p style="color: green;">CCS-27. "VEHICLE-TO-VEHICLE DISTANCE CONTROL MODE FUNCTION : Menu Displayed by Pressing Each Switch"</p>
ICC system warning (Vehicle-to-vehicle distance control mode)	 <p style="text-align: right; font-size: small;">JSOIA0893ZZ</p>	

A
B
C
D
E
F
G
H
I
J
K
L
M
N
P

CCS

SYSTEM

< SYSTEM DESCRIPTION >

[ICC]

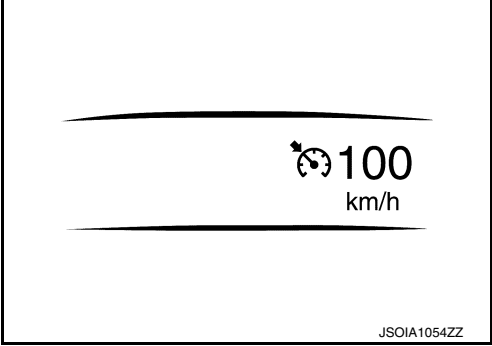
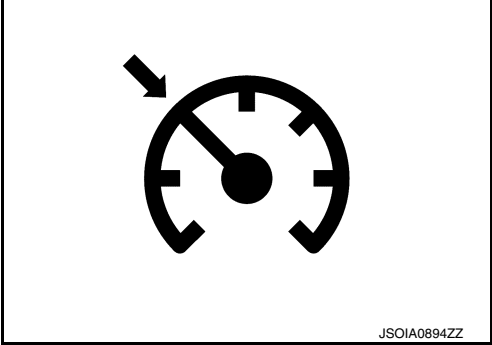
Name	Design	Function
ICC system display (conventional (fixed speed) cruise control mode)	 <p style="text-align: right; font-size: small;">JSOIA1054ZZ</p>	
ICC system warning (conventional (fixed speed) cruise control mode)	 <p style="text-align: right; font-size: small;">JSOIA0894ZZ</p>	<p style="color: green; font-size: small;">CCS-31. "CONVENTIONAL (FIXED SPEED) CRUISE CONTROL MODE FUNCTION : Menu Displayed by Pressing Each Switch"</p>

OPERATION

VEHICLE-TO-VEHICLE DISTANCE CONTROL MODE FUNCTION

VEHICLE-TO-VEHICLE DISTANCE CONTROL MODE FUNCTION : Switch Name and Function

INFOID:000000013711789

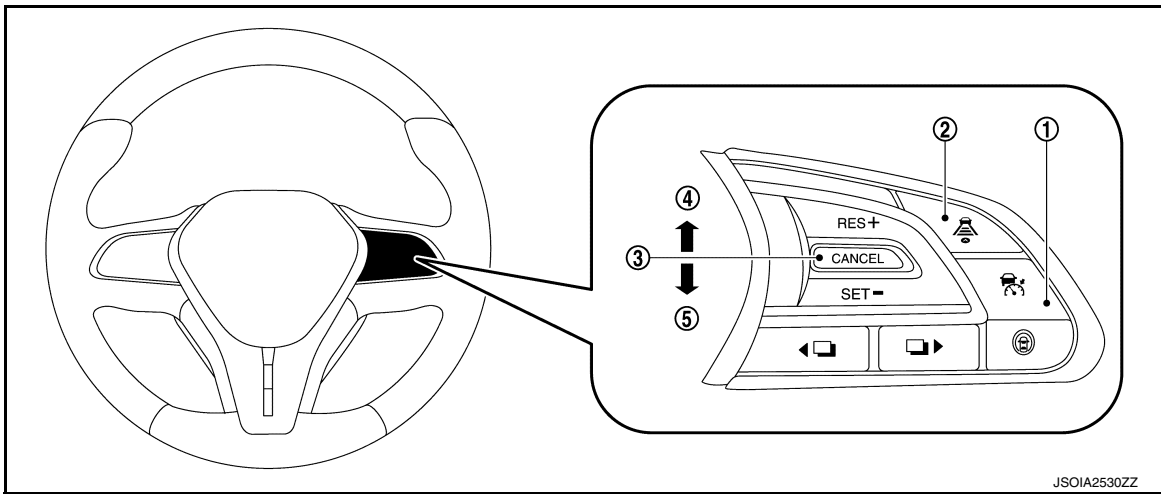

No.	Switch name	Description
①	MAIN switch	Master switch to activate the system (Press for less than 1.5 seconds)
②	DISTANCE switch	Changes the following distance from: Long, Middle, Short
③	CANCEL switch	Deactivates the system without erasing the set speed
④	RESUME/ACCELERATE switch	Resumes set speed or increases speed incrementally • Push and hold the switch to increase the set speed by 5 km/h (5 MPH) • Push then quickly release the switch to increase the set speed by 1 km/h (1 MPH)
⑤	SET/COAST switch	Sets desired cruise speed or reduces speed incrementally • Push and hold the switch to decrease the set speed by 5 km/h (5 MPH) • Push then quickly release the switch to decrease the set speed by 1 km/h (1 MPH) NOTE: The minimum set speed is 32 km/h (20 MPH)

VEHICLE-TO-VEHICLE DISTANCE CONTROL MODE FUNCTION : Menu Displayed by Pressing Each Switch

INFOID:000000013711790

ICC SYSTEM DISPLAY (ON THE INFORMATION DISPLAY)

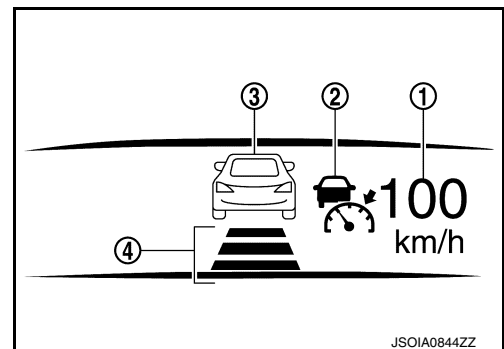

No.	Switch name	Description
①	Set vehicle speed indicator	• Indicates the set vehicle speed • Indicates 32 km/h (20 MPH) when setting less than 32 km/h (20 MPH)

A
B
C
D
E
F
G
H
I
J
K
L
M
N
P

CCS

OPERATION

< SYSTEM DESCRIPTION >





[ICC]

No.	Switch name	Description
②	ICC system warning lamp (yellow)	Indicates that a malfunction occurs in the ICC system
	MAIN switch indicator (white)	Indicates that the MAIN switch is ON (ICC system ON)
	Set switch indicator (green)	Indicates that the set vehicle to vehicle distance control mode is controlled
③	Vehicle ahead detection indicator	Indicates whether it detects a vehicle ahead
④	Set distance indicator	Indicates the selected distance between vehicles set with the DISTANCE switch

SYSTEM CONTROL CONDITION DISPLAY

Quickly push (less than 1.5 seconds) and release the MAIN switch ON.



The MAIN switch indicator (cruise indicator), set distance indicator, own vehicle indicator, and set vehicle speed indicator come on and ICC system is set to a standby state.

Condition		Display on ICC system display
Standby mode		 <p style="text-align: right; font-size: small;">JSOIA0845ZZ</p>
Control mode	Without a vehicle ahead	Set vehicle distance (Long)  <p style="text-align: right; font-size: small;">JSOIA0846ZZ</p>
		Set vehicle distance (Middle)  <p style="text-align: right; font-size: small;">JSOIA0847ZZ</p>
		Set vehicle distance (Short)  <p style="text-align: right; font-size: small;">JSOIA0848ZZ</p>
		When the vehicle speed exceeds the set speed  <p style="text-align: right; font-size: small;">JSOIA0849ZZ</p>

OPERATION

< SYSTEM DESCRIPTION >

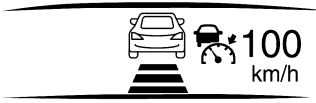
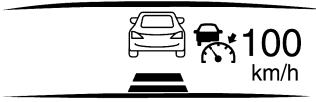
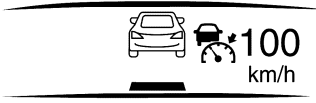
[ICC]

		Condition	Display on ICC system display	
Control mode	With a vehicle ahead	Set vehicle distance (Long)	 <small>JSOIA0850ZZ</small>	A
		Set vehicle distance (Middle)	 <small>JSOIA0851ZZ</small>	B
		Set vehicle distance (Short)	 <small>JSOIA0852ZZ</small>	C
		When the vehicle speed exceeds the set speed	 <small>JSOIA0853ZZ</small>	D

NOTE:

The display of the DCA system is given priority when the DCA system is ON in a standby mode. (The set vehicle speed indicator, and set distance indicator, are not displayed).

APPROACH WARNING DISPLAY

If own vehicle comes closer to a vehicle ahead due to rapid deceleration of that vehicle or if another vehicle cuts in, the system warns the driver with the chime and ICC system display. Decelerate by depressing the brake pedal to maintain a safe vehicle distance if:

- The chime sounds.
- The vehicle ahead detection indicator and set distance indicator blink.

The warning chime may not sound in some cases when there is a short distance between vehicles. Some examples are:

- When the vehicles are traveling at the same speed and the distance between vehicles is not changing.
- When the vehicle ahead is traveling faster and the distance between vehicles is increasing.
- When a vehicle cuts in at near own vehicle.

The warning chime will not sound when own vehicle approaches vehicles that are parked or moving slowly. The warning chime will not sound when the accelerator pedal is depressed, overriding the system.

The approach warning chime may sound and the system display may blink when the ICC sensor detects objects on the side of the vehicle or some reflectors on the side of the road.

This may cause the ICC system to decelerate or accelerate the vehicle.

The ICC sensor may detect these object when the vehicle is driven on winding roads, hilly roads or when entering or exiting a curve.

The ICC sensor may also detect object on narrow roads or in road construction zones.

In these cases driver will have to manually control the proper distance ahead of own vehicle.

Also, the sensor sensitivity can be affected by vehicle operation (steering maneuver or driving position in the lane) or traffic or vehicle condition (for example, if a vehicle is being driven with some damage).



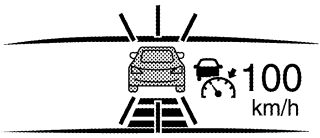

OPERATION

< SYSTEM DESCRIPTION >

[ICC]

Condition	Display on ICC system display
<p>When own vehicle comes closer to the vehicle ahead and it is judged that the distance between the vehicles is not sufficient</p>	 <p style="text-align: right; font-size: small;">JSOIA1047ZZ</p>

WARNING LAMP AND AUTOMATIC CANCELLATION DISPLAY

	Condition	Description	Display on ICC system display
Warning display	<ul style="list-style-type: none"> When the VDC is turned OFF When the VDC or ABS (including the TCS) operates When a wheel slips When the drive mode select switch is in SNOW mode 	<p>NOTE: When the conditions listed above are no longer present, turn the system OFF using the MAIN switch. Turn the ICC system back on to use the system.</p>	<p>(Yellow)</p>  <p style="text-align: right; font-size: small;">JSOIA1048ZZ</p>
			<p>Currently unavailable</p>  <p style="text-align: right; font-size: small;">JSOIA0857ZZ</p>
	<p>When the front bumper grille near the ICC sensor is dirty, making it impossible to detect a vehicle ahead.</p>	<p>A chime sounds and the control is automatically canceled. NOTE: Park the vehicle in a safe place, turn the engine OFF. Clean the front bumper grille near the ICC sensor and then perform the settings again.</p>	<p>(Yellow)</p>  <p style="text-align: right; font-size: small;">JSOIA1048ZZ</p>
			<p>Unavailable Front Radar Obstruction</p>  <p style="text-align: right; font-size: small;">JSOIA0857ZZ</p>

OPERATION

< SYSTEM DESCRIPTION >

[ICC]

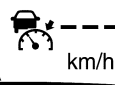
Condition		Description	Display on ICC system display
Warning display	When the ICC system is malfunctioning	A chime sounds and the control is automatically canceled. NOTE: Turn the engine OFF and restart engine. If there is no malfunction, it is possible to set the system.	(Yellow)  JSOIA1049ZZ
Automatic cancellation display	<ul style="list-style-type: none"> When brake pedal is depressed When CANCEL switch is pressed When a vehicle ahead is not detected below the speed of 24 km/h (15 MPH) When the system judges the vehicle is at standstill When the selector lever is not in "D" position or manual mode When the parking brake are applied 	A chime sounds and the control is automatically canceled. NOTE: <ul style="list-style-type: none"> The system will be in a standby, after the control is automatically canceled. A chime sounds when the control is automatically canceled, except when brake pedal is depressed or when CANCEL switch is pressed. 	 JSOIA0845ZZ

NOTE:

When the ICC system is automatically canceled, the cancellation condition can be displayed on "WORK SUPPORT" of CONSULT (ICC/ADAS).

CONVENTIONAL (FIXED SPEED) CRUISE CONTROL MODE FUNCTION

CONVENTIONAL (FIXED SPEED) CRUISE CONTROL MODE FUNCTION : Switch Name and Function

INFOID:000000013711791

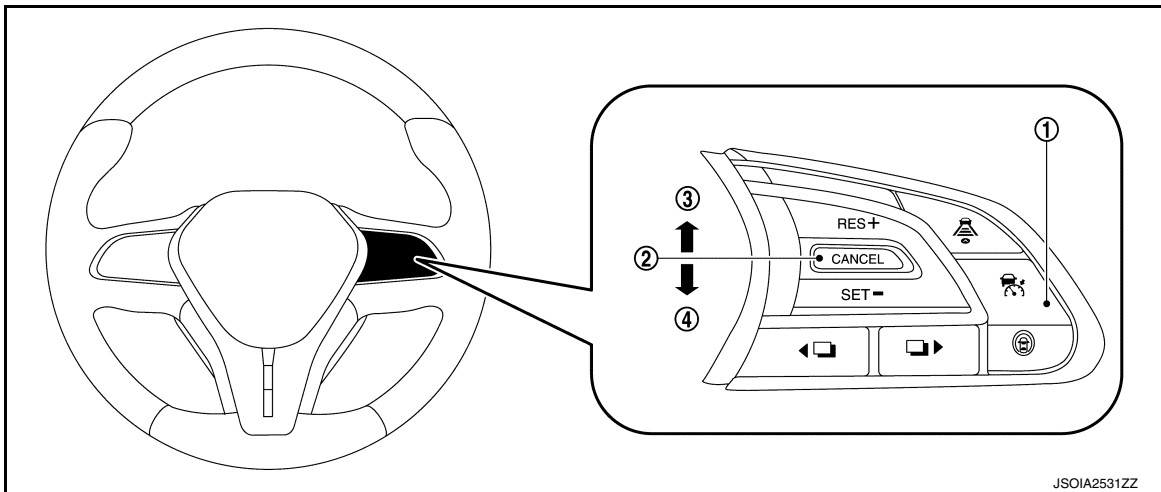

No.	Description	Function
①	MAIN switch	Master switch to activate the system (Press for more than 1.5 seconds)
②	CANCEL switch	Deactivates system without erasing set speed
③	RESUME/ACCELERATE switch	Resumes set speed or increases speed incrementally
④	SET/COAST switch	Sets desired cruise speed or reduces speed incrementally

CONVENTIONAL (FIXED SPEED) CRUISE CONTROL MODE FUNCTION : Menu

OPERATION

< SYSTEM DESCRIPTION >

[ICC]

Displayed by Pressing Each Switch

INFOID:000000013711792

ICC SYSTEM DISPLAY (ON THE INFORMATION DISPLAY)

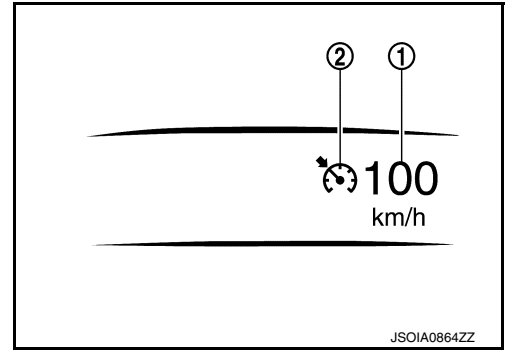

No.	Description	Function
①	Set vehicle speed indicator	Indicates the set vehicle speed
②	ICC system warning (yellow)	Indicates that a malfunction occurs in the ICC system
	MAIN switch indicator (white)	Indicates that the MAIN switch is ON (ICC system ON)
	SET switch indicator (green)	Indicates that the set conventional (fixed speed) cruise control mode is controlled

SYSTEM CONTROL CONDITION DISPLAY

Push and hold the MAIN switch for longer than approximately 1.5 seconds. This mode will be in a standby state for setting.

Condition	Display on ICC system display
Standby mode	<p style="text-align: right; font-size: small;">JSOIA0865ZZ</p>
Control mode	<p style="text-align: right; font-size: small;">JSOIA0866ZZ</p>

WARNING AND AUTOMATIC CANCELLATION DISPLAY

OPERATION

< SYSTEM DESCRIPTION >

[ICC]

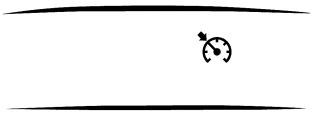
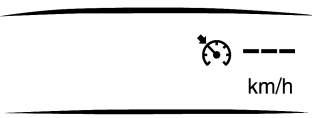
Condition		Description	Display on ICC system display	
Warning display	When the ICC system is malfunctioning	A chime sounds and the control is automatically canceled NOTE: Turn the engine OFF and restart engine. If there is no malfunction, it is possible to set the system	(Yellow)  JSOIA0867ZZ	A
				B
System cancel display	<ul style="list-style-type: none"> When brake pedal is depressed When pressing CANCEL switch When the vehicle slows down more than 13 km/h (8 MPH) below the set speed When the selector lever is not in the "D" position or manual mode When the parking brakes are applied When VDC (including the TCS) operates When a wheel slips 	A chime sounds and the control is automatically canceled NOTE: <ul style="list-style-type: none"> The system will be in a standby, after the control is automatically canceled A chime sounds when the control is automatically canceled, except when brake pedal is depressed or when CANCEL switch is pressed 	(White)  JSOIA0865ZZ	C
				D
				E
				F
				G
				H

NOTE:
 When the ICC system is automatically canceled, the cancellation condition can be displayed on "WORK SUPPORT" of CONSULT (ICC/ADAS).

CCS

HANDLING PRECAUTION

Precautions for Vehicle-to-Vehicle Distance Control Mode

INFOID:000000013711793

- ICC system is only an aid to assist the driver and is not a collision warning or avoidance device. It is the driver's responsibility to stay alert, drive safely and be in control of the vehicle at all times.
- The system is primarily intended for use on straight, dry, open roads with light traffic. It is not advisable to use the system in city traffic or congested areas.
- This system will not adapt automatically to road conditions. This system should be used in evenly flowing traffic. Do not use the system on roads with sharp curves, or on icy roads, in heavy rain or in fog.
- The ICC sensor will not detect under most conditions.
 - Stationary and slow moving vehicles.
 - Pedestrians or objects in the roadway.
 - Oncoming vehicles in the same lane.
 - Motorcycles traveling offset in the travel lane.
- As there is a performance limit to the distance control function, never rely solely on the ICC system. This system does not correct careless, inattentive or absent-minded driving, or overcome poor visibility in rain, fog, or other bad weather. Decelerate the vehicle speed by depressing the brake pedal, depending on the distance to the vehicle ahead and the surrounding circumstances in order to maintain a safe distance between vehicles.
- If the vehicle ahead comes to a stop, the vehicle decelerates to a standstill within the limitations of the system. The system will cancel once it judges that the vehicle has come to a standstill and sound a warning chime. To prevent the vehicle from moving, the driver must depress the brake pedal.
- The system may not detect the vehicle in front of the driver in certain road or weather conditions. To avoid accidents, never use the ICC system under the following conditions:
 - On roads where the traffic is heavy or there are sharp curves.
 - On slippery road surfaces such as on ice or snow, etc.
 - During bad weather (rain, fog, snow, etc.)
 - When rain, snow or dirt adhere to the system sensor.
 - On steep downhill roads (the vehicle may go beyond the set vehicle speed and frequent braking may result in overheating the brakes).
 - On repeated uphill and downhill roads.
 - When traffic conditions make it difficult to keep a proper distance between vehicles because of frequent acceleration or deceleration.
- In some road or traffic conditions, a vehicle or object can unexpectedly come into the sensor detection zone and cause automatic braking. The driver may need to control the distance from other vehicles using the accelerator pedal. Always stay alert and avoid using the ICC system when it is not recommended in this section.
- The vehicle-to-vehicle distance control mode uses a sensor located behind the lower grille of the front bumper to detect vehicles traveling ahead. The sensor generally detects the signals returned from the vehicle ahead. Therefore, if the sensor cannot detect the reflection from the vehicle ahead, the ICC system may not maintain the selected distance.
 - The following are some conditions in which the sensor cannot detect the signals:
 - When the snow or road spray from traveling vehicles reduces the sensor's visibility.
 - When excessively heavy baggage is loaded in the rear seat or the trunk room of own vehicle.
- The ICC system is designed to automatically check the sensor's operation within the limitation of the system. When the sensor area of the front bumper is covered with dirt or is obstructed, the system will automatically be canceled. If the sensor is covered with ice, a transparent or translucent vinyl bag, etc., the ICC system may not detect them. In these instances, the vehicle-to-vehicle distance control mode may not cancel and may not be able to maintain the selected following distance from the vehicle ahead. Be sure to check and clean the sensor regularly.
- The ICC system does not control vehicle speed or warn the driver when own vehicle approaches stationary and slow moving vehicles. The driver must pay attention to vehicle operation to maintain proper distance from vehicles ahead when approaching toll gates or traffic congestion.

HANDLING PRECAUTION

[ICC]

< SYSTEM DESCRIPTION >

- The detection zone of the ICC sensor is limited. A vehicle ahead must be in the detection zone for the vehicle-to-vehicle distance detection mode to maintain the selected distance from the vehicle ahead. A vehicle ahead may move outside of the detection zone due to its position within the same lane of travel. Motorcycles may not be detected in the same lane ahead if they are traveling offset from the center line of the lane. A vehicle that is entering the lane ahead may not be detected until the vehicle has completely moved into the lane. If this occurs, the ICC system may warn the driver by blinking the system indicator and sounding the chime. The driver may have to manually control the proper distance away from vehicle traveling ahead.

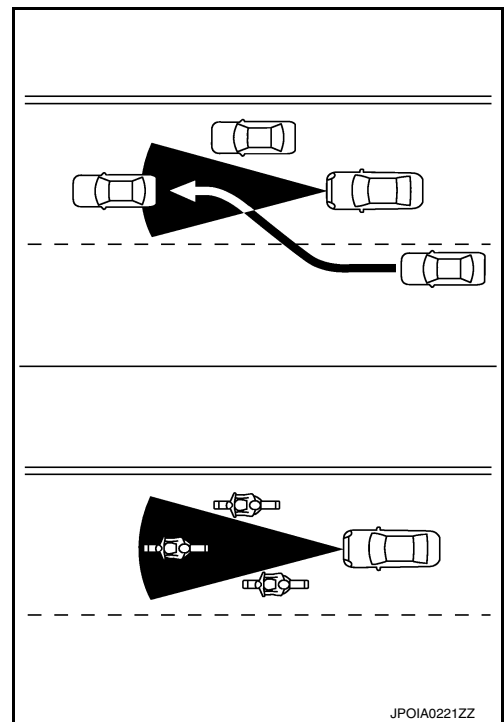

- When driving on some roads, such as winding, hilly, curved, narrow roads, or roads which are under construction, the ICC sensor may detect vehicles in a different lane, or may temporarily not detect a vehicle traveling ahead. This may cause the ICC system to decelerate or accelerate the vehicle. The detection of vehicles may also be affected by vehicle operation (steering maneuver or traveling position in the lane, etc.) or vehicle condition. If this occurs, the ICC system may warn the driver by blinking the system indicator and sounding the chime unexpectedly. The driver will have to manually control the proper distance away from the vehicle traveling ahead.

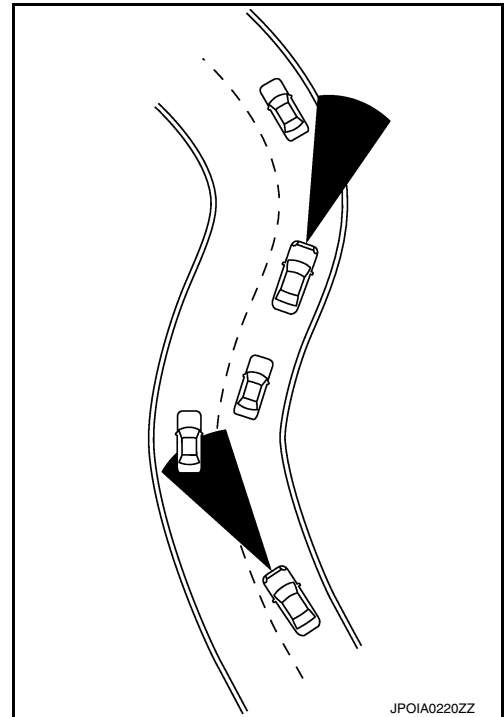

- When driving on the freeway at a set speed and approaching a slower traveling vehicle ahead, the ICC will adjust the speed to maintain the distance, selected by the driver, from the vehicle ahead. If the vehicle ahead changes lanes or exits the freeway, the ICC system will accelerate and maintain the speed up to the set speed. Pay attention to the driving operation to maintain control of the vehicle as it accelerates to the set speed. The vehicle may not maintain the set speed on winding or hilly roads. If this occurs, the driver will have to manually control the vehicle speed.

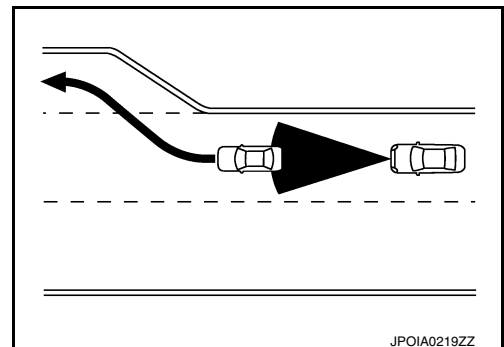

A
B
C
D
E
F
G
H
I
J
K
L
M
N

CCS

P

HANDLING PRECAUTION

< SYSTEM DESCRIPTION >

[ICC]

- Normally when controlling the distance to a vehicle ahead, this system automatically accelerates or decelerates own vehicle according to the speed of the vehicle ahead. Depress the accelerator to properly accelerate own vehicle when acceleration is required for a lane change. Depress the brake pedal when deceleration is required to maintain a safe distance to the vehicle ahead due to its sudden braking or if a vehicle cuts in. Always stay alert when using the ICC system.

Precautions for Conventional (Fixed Speed) Cruise Control Mode

INFOID:000000013711794

- In the conventional (fixed speed) cruise control mode, a warning chime does not sound to warn the driver if own vehicle is too close to the vehicle ahead, as neither the presence of the vehicle ahead nor the vehicle-to-vehicle distance is detected.
- Pay special attention to the distance between own vehicle and the vehicle ahead or a collision could occur.
- Always confirm the setting in the ICC system display.
- Do not use the conventional (fixed speed) cruise control mode when driving under the following conditions:
 - When it is not possible to keep the vehicle at a set speed.
 - In heavy traffic or in traffic that varies in speed.
 - On winding or hilly roads.
 - On slippery roads (rain, snow, ice, etc.).
 - In very windy areas.
 - Doing so could cause a loss of vehicle control and result in an accident.
 - To avoid accidentally engaging cruise control, make sure to turn the MAIN switch off when not using the ICC system.

DIAGNOSIS SYSTEM (ADAS CONTROL UNIT)

< SYSTEM DESCRIPTION >

[ICC]

DIAGNOSIS SYSTEM (ADAS CONTROL UNIT)

On Board Diagnosis Function (With ICC)

INFOID:000000013965355

DESCRIPTION

The DTC is displayed on the information display by operating the ICC steering switch.

On Board Self-diagnosis System Diagram (VR30DDTT)

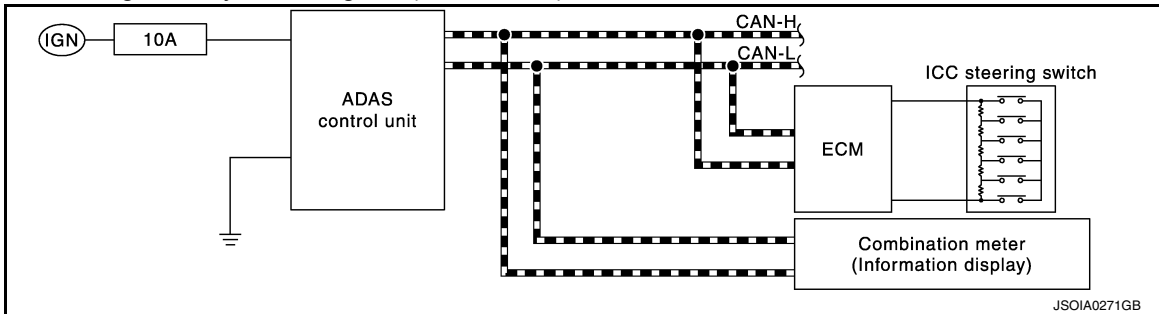

On Board Self-diagnosis System Diagram (2.0 TURBO GASOLINE ENGINE)

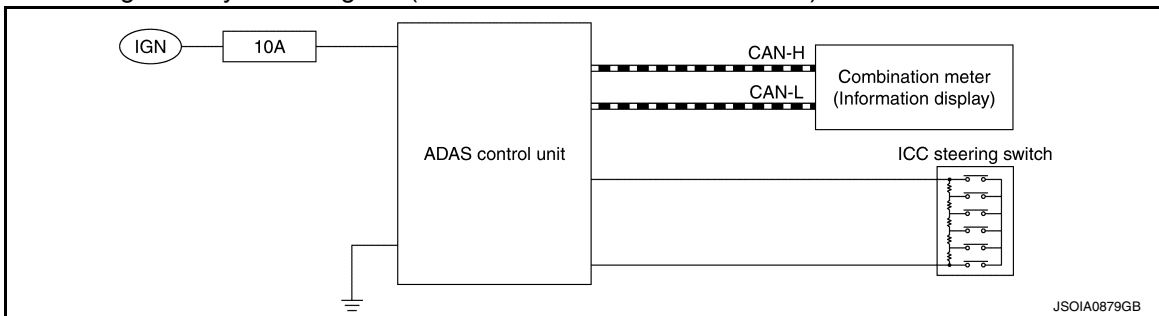

METHOD OF STARTING

CAUTION:

Start condition of on board self-diagnosis

- ICC system OFF
- DCA system OFF
- Vehicle speed 0 km/h (0 MPH)

1. Turn the ignition switch OFF.
2. Start the engine.
3. Wait for 5 seconds after starting the engine. Push up the RESUME/ACCELERATE switch 5 times and push down the SET/COAST switch 5 times within 10 seconds.

NOTE:

If the above operation cannot be performed within 10 seconds after waiting for 5 seconds after starting the engine, repeat the procedure from step 1.

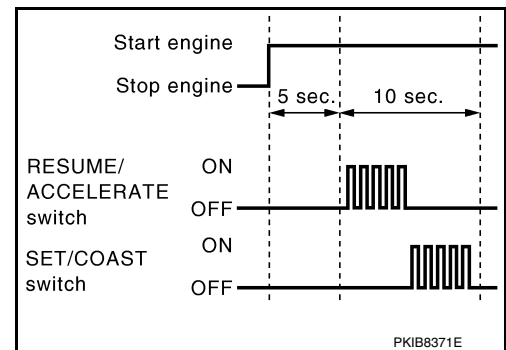

A
B
C
D
E
F
G
H
I
J
K
L
M
N
P

DIAGNOSIS SYSTEM (ADAS CONTROL UNIT)

[ICC]

< SYSTEM DESCRIPTION >

4. The DTC is displayed on the set vehicle speed indicator ① on the ICC system display on the information display when the on board self-diagnosis starts. Refer to [CCS-229. "DTC Index"](#).

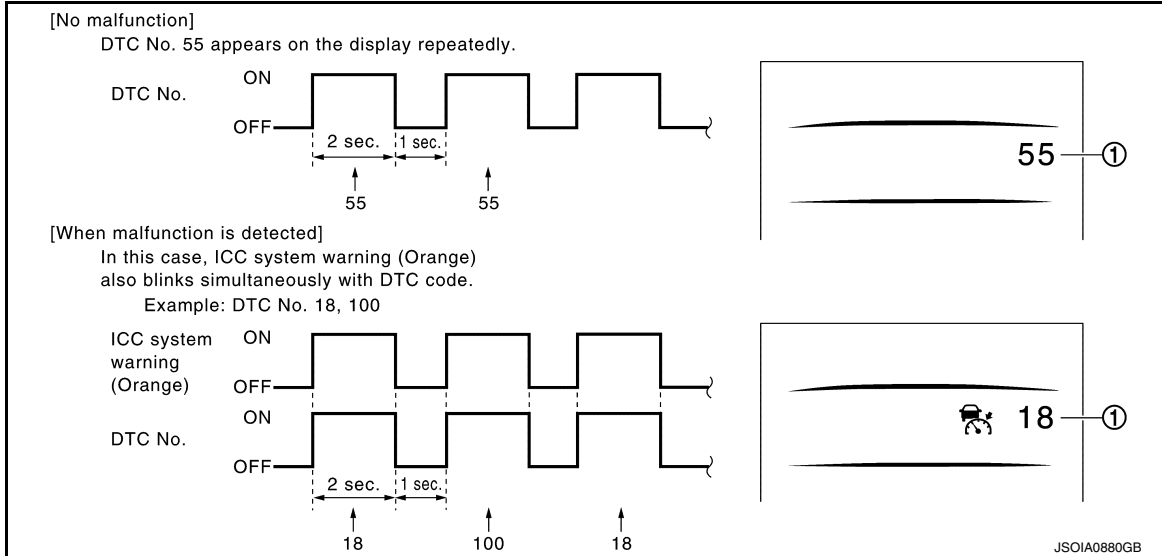

NOTE:

- It displays for up to 5 minutes and then stops.
- If multiple malfunctions exist, up to 6 DTCs can be stored in memory at the most, and the most recent one is displayed first.

WHEN THE ON BOARD SELF-DIAGNOSIS DOES NOT START

If the on board self-diagnosis does not start, check the following items.

Assumed abnormal part		Inspection item
Information display	Combination meter malfunction	Check that the self-diagnosis function of the combination meter operates. Refer to MWI-72. "On Board Diagnosis Function" .
ICC/ASCD steering switch malfunction		Perform the inspection for DTC "C1A06". Refer to DAS-149. "ADAS CONTROL UNIT : DTC Description" .
Harness malfunction between ICC steering switch and ECM		
Harness malfunction between ASCD steering switch and ADAS control unit		
ECM malfunction		
ADAS control unit malfunction		<ul style="list-style-type: none"> • Check power supply and ground circuit of ADAS control unit. Refer to DAS-350. "ADAS CONTROL UNIT : Diagnosis Procedure". • Perform SELF-DIAGNOSIS for "ICC/ADAS" with CONSULT, and then check the malfunctioning parts. Refer to CCS-229. "DTC Index".

HOW TO ERASE ON BOARD SELF-DIAGNOSIS

1. Turn the ignition switch OFF.
2. Start the engine, and then start the on board self-diagnosis.
3. Press the CANCEL switch 5 times, and then press the DISTANCE switch 5 times under the condition that the on board self-diagnosis starts.

NOTE:

- Complete the operation within 10 seconds after pressing the CANCEL switch first.
- If the operation is not completed within 10 seconds, repeat the procedure from step 1.

4. DTC 55 is displayed after erasing.

NOTE:

DTCs for existing malfunction can not be erased.

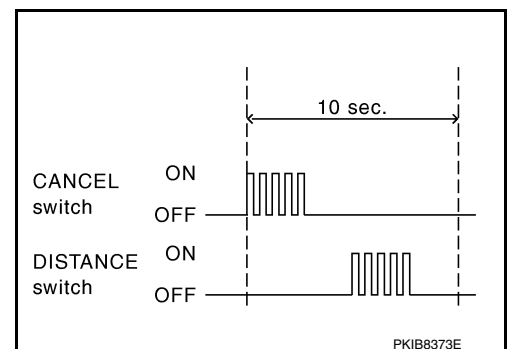

DIAGNOSIS SYSTEM (ADAS CONTROL UNIT)

< SYSTEM DESCRIPTION >

[ICC]

5. Turn ignition switch OFF, and finish the diagnosis.

CONSULT Function (ICC/ADAS)

INFOID:000000013965356

APPLICATION ITEMS

CONSULT performs the following functions via CAN communication using ADAS control unit.

Diagnosis mode	Description
Configuration*	<ul style="list-style-type: none"> The vehicle specification that is written in ADAS control unit can be displayed or stored The vehicle specification can be written when ADAS control unit is replaced
Work Support	Displays causes of automatic system cancellation occurred during system control
Self Diagnostic Result	Displays the name of a malfunctioning system stored in the ADAS control unit
Data Monitor	Displays ADAS control unit input/output data in real time
Active Test	Enables an operational check of a load by transmitting a driving signal from the ADAS control unit to the load
ECU Identification	Displays ADAS control unit part number
CAN Diag Support Monitor	Displays a reception/transmission state of CAN communication and ITS communication

*: Models with FEB system only.

CONFIGURATION

Configuration includes functions as follows.

NOTE:

Models with FEB system only.

Function	Description	
Read/Write Configuration	Before Replace ECU	Allows the reading of vehicle specification written in ADAS control unit to store the specification in CONSULT.
	After Replace ECU	Allows the writing of the vehicle information stored in CONSULT into the ADAS control unit.
Manual Configuration	Allows the writing of the vehicle specification into the ADAS control unit by hand.	

WORK SUPPORT

Work support items	Description
CAUSE OF AUTO-CANCEL 1	Displays causes of automatic system cancellation occurred during control of the following systems <ul style="list-style-type: none"> Vehicle-to-vehicle control mode Conventional (fixed speed) control mode Distance Control Assist (DCA) Forward Emergency Braking (FEB)
CAUSE OF AUTO-CANCEL 2	Displays causes of automatic system cancellation occurred during control of the following systems <ul style="list-style-type: none"> Lane Departure Prevention (LDP) (Without DAST) Blind Spot Intervention (Without DAST)
CAUSE OF AUTO-CANCEL 3	Displays causes of automatic system cancellation occurred during control of the Back-up Collision Intervention (BCI)
FEB OPERATION MILEAGE	Displays mileage at FEB system operation
FEB DEFAULT SETTING	ON/OFF setting of FEB system at engine start can be changed

NOTE:

- Causes of the maximum five cancellations (system cancel) are displayed.
- The displayed cancellation causes display the number of the ignition switch ON/OFF up to 254. It is fixed to 254 if it is over 254. It returns to 0 when the same cancellation cause is detected again.

Display Items for The Cause of Automatic Cancellation 1

DIAGNOSIS SYSTEM (ADAS CONTROL UNIT)

< SYSTEM DESCRIPTION >

[ICC]

Cause of cancellation	Vehicle-to-vehicle distance control mode	•Conventional (fixed speed) cruise control mode •Automatic Speed Control Device (ASCD)	Distance Control Assist	Forward Emergency Braking	Description
OPERATING ABS	×		×	×	ABS function was operated
OPERATING TCS	×	×	×		TCS function was operated
OPERATING VDC	×	×	×	×	VDC function was operated
ECM CIRCUIT	×	×			ECM did not permit ICC operation
OPE SW VOLT CIRC	×	×	×		The ICC steering switch input voltage is not within standard range
SNOW MODE SW	×		×		Shifting of the drive mode selector to SNOW position
OP SW DOUBLE TOUCH	×	×			ICC steering switches were pressed at the same time
VHCL SPD DOWN	×	×	×		Vehicle speed lower than the speed as follows <ul style="list-style-type: none"> • Vehicle-to-vehicle distance control mode is 24 km/h (15 MPH) • Conventional (fixed speed) cruise control mode is 32 km/h (20 MPH)
WHL SPD ELEC NOISE	×	×	×		Wheel speed sensor signal caught electromagnetic noise
VDC/TCS OFF SW	×		×	×	VDC OFF switch was pressed
VHCL SPD UNMATCH	×	×	×		Wheel speed became different from A/T vehicle speed
TIRE SLIP	×	×			Wheel slipped
IGN LOW VOLT	×	×	×	×	Decrease in ADAS control unit ignition voltage
PARKING BRAKE ON	×	×			The parking brake is operating
WHEEL SPD UNMATCH	×	×	×		The wheel speeds of 4 wheels are out of the specified values
INCHING LOST	×				A vehicle ahead is not detected during the following driving when the vehicle speed is approximately 24 km/h (15 MPH) or less
CAN COMM ERROR	×	×	×	×	ADAS control unit received an abnormal signal with CAN communication
ABS/TCS/VDC CIRC	×	×	×	×	An abnormal condition occurs in VDC/TCS/ABS system
ECD CIRCUIT	×	×	×	×	An abnormal condition occurs in ECD system
ENG SPEED DOWN	×	×			Engine speed became extremely low while controlling ICC system
ASCD VHCL SPD DTAC		×			Vehicle speed is detached from set vehicle speed
ASCD DOUBLE COMD		×			Cancel switch and operation switch are detected simultaneously
APA HI TEMP			×		The accelerator pedal actuator integrated motor temperature is high
ICC SENSOR CAN COMM ERR	×		×	×	Communication error between ADAS control unit and the ICC sensor
ABS WARNING LAMP	×		×		ABS warning lamp ON
FR RADAR BLOCKED	×		×	×	Inclusion of dirt or stains on the ICC sensor area of the front bumper

DIAGNOSIS SYSTEM (ADAS CONTROL UNIT)

< SYSTEM DESCRIPTION >

[ICC]

FEB) CURVATURE				×	Road curve was more than the specified value	A
FEB) YAW RATE				×	Detected yawing speed was more than the specified value	A
FEB) LTRL ACCELERATION				×	Detected lateral speed is the specified value or more	B
RADAR INTERFERENCE	×		×	×	ICC sensor receives electromagnetic interference	B
LANE CAMERA BLOCKED				×	Inclusion of dirt or stain on lane camera field of view (example) window with fogging, window with dirt, strong light from front etc...)	C
Lane camera offset center				×	Significant change in vehicle attitude or improper installation position of lane camera NOTE: If "Lane camera offset center" is frequently detected, check vehicle attitude (e.g. tire pressure) and installation condition of lane camera. After this inspection, perform front camera aiming again.	D
NO RECORD	×	×	×		—	E

Display Items for The Cause of Automatic Cancellation 2

Cause of cancellation	Lane departure prevention	Blind spot intervention	Description	
OPE VDC/TCS/ABS 1	×		The activation of VDC, TCS, or ABS during LDP system control	F
Vehicle dynamics	×		Vehicle behavior exceeds specified value	G
Steering speed	×		Steering speed was more than the specified value in evasive direction	H
End by yaw angle	×		Yaw angle was the end of LDP control	I
Departure yaw large	×		Detected more than the specified value of yaw angle in departure direction	J
ICC WARNING	×		Target approach warning of ICC system, FEB system, or PFCW system was activated	K
CURVATURE	×		Road curve was more than the specified value	L
Steering angle large	×		Steering angle was more than the specified value	M
Brake is operated	×		Brake pedal was operated	N
IGN LOW VOLT	×		Decrease in ADAS control unit IGN voltage	O
Lateral offset	×		Distance of vehicle and lane was detached in lateral direction more than the specified value	P
Lane marker lost	×		Lane camera unit lost the trace of lane marker	Q
Lane marker unclear	×		Detected lane marker was unclear	R
Yaw acceleration	×		Detected yawing speed was more than the specified value	S
Deceleration large	×		Deceleration in a longitudinal direction was more than the specified value	T
Accel is operated	×		Accelerator pedal was depressed	U
Departure steering	×		Steering wheel was steered more than the specified value in departure direction	V
Evasive steering	×		Steering wheel was steered more than the specified value in the evasive direction	W
R range	×		Selector lever was operated to R range	X
Parking brake drift	×		Rear wheels lock was detected	Y
Not operating condition	×		Did not meet the operating condition (vehicle speed, turn signal operation, etc.)	Z
SNOW MODE SW	×		Shifting of the drive mode selector to SNOW position	AA
VDC OFF SW	×		VDC OFF switch was pressed	AB

DIAGNOSIS SYSTEM (ADAS CONTROL UNIT)

< SYSTEM DESCRIPTION >

[ICC]

Cause of cancellation	Lane departure prevention	Blind spot intervention	Description
OPE VDC/ABS 2	×		The activation of VDC or ABS during a standby time of LDP system control
BSI WARNING	×		Blind Spot Intervention system was activated
LANE CAMERA BLOCKED	×		Inclusion of dirt or stain on lane camera field of view (example) window with fogging, window with dirt, strong light from front etc...)
Lane camera offset center	×		Significant change in vehicle attitude or improper installation position of lane camera NOTE: If "Lane camera offset center" is frequently detected, check vehicle attitude (e.g. tire pressure) and installation condition of lane camera. After this inspection, perform front camera aiming again.
BSI) OPE VDC/TCS/ABS 1		×	The activation of VDC, TCS, or ABS during Blind Spot Intervention system control
BSI) Vehicle dynamics		×	Vehicle behavior exceeds specified value
BSI) Steering speed		×	Steering speed was more than the specified value in evasive direction
BSI) End by yaw angle		×	Yaw angle was the end of Blind Spot Intervention control
BSI) Departure yaw large		×	Detected more than the specified value of yaw angle in departure direction
BSI) ICC WARNING		×	Target approach warning of ICC system, FEB system or PFCW system was activated
BSI) CURVATURE		×	Road curve was more than the specified value
BSI) Steering angle large		×	Steering angle was more than the specified value
BSI) Brake is operated		×	Brake pedal was operated
BSI) IGN LOW VOLT		×	Decrease in ADAS control unit IGN voltage
BSI) Lateral offset		×	Distance of vehicle and lane was detached in lateral direction more than the specified
BSI) Lane marker lost		×	Lane camera unit lost the trace of lane marker
BSI) Lane marker unclear		×	Detected lane marker was unclear
BSI) Yaw acceleration		×	Detected yawing speed was more than the specified value
BSI) Deceleration large		×	Deceleration in a longitudinal direction was more than the specified value
BSI) Accel is operated		×	Accelerator pedal was depressed
BSI) Departure steering		×	Steering wheel was steered more than the specified value in departure direction
BSI) Evasive steering		×	Steering wheel was steered more than the specified value in the evasive direction
BSI) R range		×	Selector lever was operated to R range
BSI) Parking brake drift		×	Rear wheels lock was detected
BSI) SNOW MODE SW		×	Shifting of the drive mode selector to SNOW position
BSI) VDC OFF SW		×	VDC OFF switch was pressed
BSI) OPE VDC/ABS 2		×	The activation of VDC or ABS during a standby time of Blind Spot Intervention system control
BSI) Not operating condition		×	Did not meet the operating condition (vehicle speed, turn signal operation, etc.)
Side Radar Lost		×	Unrecognized side radar LH or RH by the ADAS control unit
NO RECORD	×	×	—

Display Items for The Cause of Automatic Cancellation 3

DIAGNOSIS SYSTEM (ADAS CONTROL UNIT)

< SYSTEM DESCRIPTION >

[ICC]

Cause of cancellation	Back-up Collision Intervention	Description
CAN COMM ERROR (CAN)	×	ADAS control unit received an abnormal signal with CAN communication
CAN COMM ERROR (ECD)	×	ADAS control unit received an abnormal signal with CAN communication
IGN LOW VOLT	×	Decrease in ADAS control unit ignition voltage
VEHICLE SPEED UP	×	Vehicle speed higher than 8 km/h (5 MPH)
ACCEL IS OPERATED	×	Accelerator pedal was depressed
BRAKE IS OPERATED	×	Brake pedal was operated
APA HI TEMP	×	The accelerator pedal actuator integrated motor temperature is high
APA POWER	×	Decrease in accelerator pedal actuator ignition or battery voltage
NO RECORD	×	—

FEB Default Setting

Setting item	Description
On (Factory setting)	FEB are turned ON automatically when engine started.
Off	FEB are not turned ON automatically when engine started.

SELF DIAGNOSTIC RESULT

Refer to [CCS-229, "DTC Index"](#).

NOTE:

- The details of time display are as per the following.
 - CRNT: A malfunction is detected now
 - PAST: A malfunction was detected in the past
- IGN counter is displayed on FFD (Freeze Frame Data).
 - 0: The malfunctions that are detected now
CAN communication system (U1000, U1010)
 - 1 - 39: It increases like 0 → 1 → 2 ... 38 → 39 after returning to the normal condition whenever the ignition switch OFF → ON. It returns to 0 when a malfunction is detected again in the process.
 - If it is over 39, it is fixed to 39 until the self-diagnosis results are erased.
 - Other than CAN communication system (Other than U1000, U1010)
 - 1 - 49: It increases like 0 → 1 → 2 ... 38 → 49 after returning to the normal condition whenever the ignition switch OFF → ON. It returns to 0 when a malfunction is detected again in the process.
 - If it is over 49, it is fixed to 49 until the self-diagnosis results are erased.

DATA MONITOR

NOTE:

The following table includes information (items) inapplicable to this vehicle. For information (items) applicable to this vehicle, refer to CONSULT display items.

A
B
C
D
E
F
G
H
I
J
K
L
M
N
P

CCS

DIAGNOSIS SYSTEM (ADAS CONTROL UNIT)

< SYSTEM DESCRIPTION >

[ICC]

Monitored item [Unit]	ALL SIG	ALL SIG (ICC)	MAIN SIG (ICC)	MAIN SIG (LDW/LDP)	MAIN SIG (BSW/BSI)	MAIN SIG (BCI)	Description
MAIN SW [On/Off]	×	×	×	×	×		Indicates [On/Off] status as judged from ICC steering switch
SET/COAST SW [On/Off]	×	×	×				Indicates [On/Off] status as judged from ICC steering switch
CANCEL SW [On/Off]	×	×	×				Indicates [On/Off] status as judged from ICC steering switch
RESUME/ACC SW [On/Off]	×	×	×				Indicates [On/Off] status as judged from ICC steering switch
DISTANCE SW [On/Off]	×	×					Indicates [On/Off] status as judged from ICC steering switch
CRUISE OPE [On/Off]	×	×	×				Indicates whether controlling or not (ON means “controlling”)
BRAKE SW [On/Off]	×	×	×	×	×	×	Indicates [On/Off] status as judged from ICC brake switch signal (ECM transmits ICC brake switch signal through CAN communication)
STOP LAMP SW [On/Off]	×	×	×	×	×	×	Indicates [On/Off] status as judged from stop lamp switch signal (ECM transmits stop lamp switch signal through CAN communication)
IDLE SW [On/Off]	×	×				×	Indicates [On/Off] status of idle switch read from ADAS control unit through CAN communication (ECM transmits On/Off status through CAN communication)
SET DISTANCE [Short/Mid/Long]	×	×	×				Indicates set distance memorized in ADAS control unit
CRUISE LAMP [On/Off]	×	×	×				Indicates [On/Off] status of MAIN switch indicator output
OWN VHCL [On/Off]	×	×					NOTE: The item is displayed, but it is not monitored
VHCL AHEAD [On/Off]	×	×					Indicates [On/Off] status of vehicle ahead detection indicator output
ICC WARNING [On/Off]	×	×					Indicates [On/Off] status of ICC system warning lamp output
VHCL SPEED SE [km/h] or [mph]	×	×	×	×	×	×	Indicates vehicle speed calculated from ADAS control unit through CAN communication [ABS actuator and electric unit (control unit) transmits vehicle speed signal (wheel speed) through CAN communication]
SET VHCL SPD [km/h] or [mph]	×	×	×				Indicates set vehicle speed memorized in ADAS control unit
BUZZER O/P [On/Off]	×	×				×	Indicates [On/Off] status of ICC warning chime output
THRTL SENSOR [deg]	×	×	×				NOTE: The item is displayed, but it is not monitored
ENGINE RPM [rpm]	×	×					Indicates engine speed read from ADAS control unit through CAN communication (ECM transmits engine speed signal through CAN communication)
WIPER SW [OFF/LOW/HIGH]	×	×					Indicates wiper [OFF/LOW/HIGH] status (BCM transmits front wiper request signal through CAN communication)
YAW RATE [deg/s]	×	×					NOTE: The item is displayed, but it is not monitored
BA WARNING [On/Off]	×	×					Indicates [On/Off] status of FEB indicator lamp output

DIAGNOSIS SYSTEM (ADAS CONTROL UNIT)

< SYSTEM DESCRIPTION >

[ICC]

Monitored item [Unit]	ALL SIG	ALL SIG (ICC)	MAIN SIG (ICC)	MAIN SIG (LDW/LDP)	MAIN SIG (BSW/BSI)	MAIN SIG (BCI)	Description
RELEASE SW NO [On/Off]	×	×		×	×	×	NOTE: The item is displayed, but it is not monitored
RELEASE SW NC [On/Off]	×	×		×	×	×	NOTE: The item is displayed, but it is not monitored
STP LMP DRIVE [On/Off]	×	×	×			×	Indicates [On/Off] status of ICC brake hold relay drive output
PRESS SENS [bar]	×	×	×				NOTE: The item is displayed, but it is not monitored
D RANGE SW [On/Off]	×	×					Indicates [On/Off] status of "D" or "M" positions read from ADAS control unit through CAN communication; ON when position "D" or "M" (TCM transmits shift position signal through CAN communication).
NP RANGE SW [On/Off]	×	×					Indicates shift position signal read from ADAS control unit through CAN communication (TCM transmits shift position signal through CAN communication)
PKB SW [On/Off]	×	×					Parking brake switch status [On/Off] judged from the parking brake switch signal that ADAS control unit readout via CAN communication is displayed (combination meter transmits the parking brake switch signal via CAN communication)
PWR SUP MONI [V]	×	×	×				Indicates IGN voltage input by ADAS control unit
VHCL SPD AT [km/h] or [mph]	×	×					Indicates vehicle speed calculated from A/T vehicle speed sensor read from ADAS control unit through CAN communication (TCM transmits A/T vehicle speed sensor signal through CAN communication)
THRTL OPENING [%]	×	×	×			×	Indicates throttle position read from ADAS control unit through CAN communication (ECM transmits accelerator pedal position signal through CAN communication).
GEAR [1, 2, 3, 4, 5, 6, 7]	×	×					Indicates A/T gear position read from ADAS control unit through CAN communication (TCM transmits current gear position signal through CAN communication)
MODE SIG [OFF, ICC, ASCD]	×	×					Indicates the active mode from ICC or ASCD [conventional (fixed speed) cruise control mode]
SET DISP IND [On/Off]	×	×					Indicates [On/Off] status of SET switch indicator output
DISTANCE [m]	×	×					Indicates the distance from the vehicle ahead
RELATIVE SPD [m/s]	×	×					Indicates the relative speed of the vehicle ahead
DYNA ASIST SW [On/Off]	×	×	×		×		Indicates [On/Off] status as judged from ICC steering switch signal (ECM transmits ICC steering switch signal through CAN communication)
DCA ON IND [On/Off]	×	×					The status [ON/OFF] of DCA system switch indicator output is displayed
DCA VHL AHED [On/Off]	×	×					The status [ON/OFF] of vehicle ahead detection indicator output in DCA system is displayed
APA TEMP [°C]	×	×				×	Accelerator pedal actuator integrated motor temperature that the ADAS control unit readout via ITS communication is displayed (Accelerator pedal actuator transmits the integrated motor temperature via ITS communication)
FCW MAIN SW							NOTE: The item is displayed, but it is not monitored

A
B
C
D
E
F
G
H
I
J
K
L
M
N
P

CCS

DIAGNOSIS SYSTEM (ADAS CONTROL UNIT)

< SYSTEM DESCRIPTION >

[ICC]

Monitored item [Unit]	ALL SIG	ALL SIG (ICC)	MAIN SIG (ICC)	MAIN SIG (LDW/LDP)	MAIN SIG (BSW/BSI)	MAIN SIG (BCI)	Description
APA PWR [V]	×	×				×	Accelerator pedal actuator power supply voltage that the ADAS control unit readout via ITS communication is displayed (Accelerator pedal actuator transmits the power supply voltage via ITS communication)
NAVI-ICC DISP [On/Off]	×	×					NOTE: The item is displayed, but it is not monitored
LDW SYSTEM ON [On/Off]	×			×			Indicates [On/Off] status of LDW system
LANE DPRT W/L [On/Off]	×			×			Indicates [On/Off] status of LDW/LDP warning display (Yellow) output
LDW BUZER OUT- PUT [On/Off]	×			×			Indicates [On/Off] status of warning buzzer output
LDP SYSTEM ON [On/Off]	×			×			Indicates [On/Off] status of LDP system
WARN REQ [On/Off]	×			×			Indicates an ADAS control unit judged warning state (ON/OFF) of LDP system
READY signal [On/Off]	×			×			Indicates LDP system settings
Camera lost [Detect/Deviate/Both]	×			×	×		Indicates a lane marker detection state judged from a lane marker detection signal read by the ADAS control unit via ITS communication (Lane camera unit transmits a lane marker signal via ITS communication)
Lane unclear [On/Off]	×			×	×		Indicates an ON/OFF state of the lane marker. The ON/OFF state is judged from a detected lane condition signal read by the ADAS control unit via ITS communication (The lane camera unit transmits a detected lane condition signal via ITS communication)
STATUS signal [Stnby/Warn/Cancel/ Off]	×			×			Indicates a control state of LDP system
Shift position [Off, P, R, N, D, M/T1 - 7]	×			×	×	×	Indicates shift position read from ADAS control unit through CAN communication (TCM transmits shift position signal through CAN communication)
Turn signal [OFF/LH/RH/LH&RH]	×			×	×		Indicates turn signal operation status read from ADAS control unit through CAN communication (BCM transmits turn indicator signal through CAN communication)
SIDE G [G]	×			×	×		Indicates lateral G acting on the vehicle. This lateral G is judged from a side G sensor signal read by ADAS control unit via CAN communication (The ABS actuator and electric unit (control unit) transmits a side G sensor signal via CAN communication)
FUNC ITEM (FCW) [On/Off]	×	×	×	×	×		Indicates systems which can be set to ON/OFF by selecting "Driver Aids" ⇒ "Emergency Assist" of the integral switch Forward Emergency Braking
FUNC ITEM (LDW) [On/Off]	×	×	×	×	×		Indicates systems which can be set to ON/OFF by selecting "Driver Aids" ⇒ "Lane" of the integral switch Lane Departure Warning
FUNC ITEM (BSW) [On/Off]	×	×	×	×	×		Indicates systems which can be set to ON/OFF by selecting "Driver Aids" ⇒ "Blind spot" of the integral switch Blind Spot Warning
FUNC ITEM (NV-ICC) [Off]	×	×	×	×	×		NOTE: The item is displayed, but it is not monitored

DIAGNOSIS SYSTEM (ADAS CONTROL UNIT)

< SYSTEM DESCRIPTION >

[ICC]

Monitored item [Unit]	ALL SIG	ALL SIG (ICC)	MAIN SIG (ICC)	MAIN SIG (LDW/LDP)	MAIN SIG (BSW/BSI)	MAIN SIG (BCI)	Description
FUNC ITEM (NV-DCA) [Off]	×	×	×	×	×		NOTE: The item is displayed, but it is not monitored
DCA SELECT [On/Off]	×	×	×	×	×		Indicates an ON/OFF state of the DCA system. The DCA system can be set to ON/OFF by selecting "Driving Aids" ⇒ "Front assist" of the integral switch
LDP SELECT [On/Off]	×	×	×	×	×		Indicates an ON/OFF state of LDP system. LDP system can be set to ON/OFF by selecting "Driving Aids" ⇒ "Lane" of the integral switch
BSI SELECT [On/Off]	×	×	×	×	×		Indicates an ON/OFF state of Blind Spot Intervention system. Blind Spot Intervention system can be set to ON/OFF by selecting "Driving Aids" ⇒ "Blind Spot" of the integral switch
FCW SELECT [On/Off]	×	×	×	×	×		Indicates an ON/OFF state of the PFCW system. The PFCW system can be set to ON/OFF by selecting "Driving Aids" ⇒ "Emergency Assist" of the integral switch
LDW SELECT [On/Off]	×	×	×	×	×		Indicates an ON/OFF state of the LDW system. The LDW system can be set to ON/OFF by selecting "Driving Aids" ⇒ "Lane" of the integral switch
BSW SELECT [On/Off]	×	×	×	×	×		Indicates an ON/OFF state of the BSW system. The BSW system can be set to ON/OFF by selecting "Driving Aids" ⇒ "Blind spot" of the integral switch
NAVI ICC SELECT [Off]	×	×	×	×	×		NOTE: The item is displayed, but it is not monitored
NAVI DCA SELECT [Off]	×	×	×	×	×		NOTE: The item is displayed, but it is not monitored
DRIVE MODE STATS [STD/SPORT/ECO/ SNOW/MID/ERROR]	×	×	×	×	×		Indicates a drive mode selector select position judged from a drive mode select switch position signal read by the ADAS control unit via CAN communication (The chassis control module transmits a switch position signal of the drive mode select switch signal via CAN communication)
BSW/BSI WARN LMP [On/Off]	×				×		Indicates [On/Off] status of Blind Spot warning malfunction
BSI ON IND [On/Off]	×				×		Indicates [On/Off] status of Blind Spot Intervention system display
BSW SYSTEM ON [On/Off]	×				×		Indicates [On/Off] status of BSW system
BSI SYSTEM ON [On/Off]	×				×		Indicates [On/Off] status of Blind Spot Intervention system
FCW SYSTEM ON [On/Off]	×	×	×				Indicates [On/Off] status of PFCW system
BCI SYSTEM ON [On/Off]	×					×	Indicates [On/Off] status of BCI system
BATTERY CIRCUIT OFF [On/Off]	×						NOTE: The item is displayed, but it is not used
LDP WARNING INDICATOR [On/Off]	×			×			Indicates [On/Off] status of LDP warning display (Yellow) output
LDW ON INDICATOR [On/Off]	×			×			Indicates [On/Off] status of LDW system ON display output
LDW WARNING INDICATOR [On/Off]	×			×			Indicates [On/Off] status of LDW system warning display output

A

B

C

D

E

F

G

H

I

J

K

L

M

N

CCS

P

DIAGNOSIS SYSTEM (ADAS CONTROL UNIT)

< SYSTEM DESCRIPTION >

[ICC]

Monitored item [Unit]	ALL SIG	ALL SIG (ICC)	MAIN SIG (ICC)	MAIN SIG (LDW/LDP)	MAIN SIG (BSW/BSI)	MAIN SIG (BCI)	Description
SYSTEM CANCEL MESSAGE [NOREQ/SLIP/ SNOW/VDC OFF]	×	×	×	×	×		Indicates status of system cancel display output
CAMERA HI TEMP MSG [On/Off]	×			×	×		Indicates [On/Off] status of lane camera unit high temperature warning display output
ITS SETTING ITEM(DCA) [On/Off]	×	×	×	×	×		Indicates the presence or absence of DCA system.
ITS SETTING ITEM(LDP) [On/Off]	×	×	×	×	×		Indicates the presence or absence of LDP system.
ITS SETTING ITEM(BSI) [On/Off]	×	×	×	×	×		Indicates the presence or absence of Blind Spot Intervention system.
BSI WARNING INDICATOR [On/Off]	×				×		Indicates [On/Off] status of Blind Spot Intervention warning display output
BSW ON INDICATOR [On/Off]	×				×		Indicates [On/Off] status of BSW system ON display output
SIDE RADAR BLOCK COND [On/Off]	×				×		Indicates [On/Off] status of side radar with dirt or foreign materials
LDW WARNING ALERT TIMING [Nothing/Early/Late]	×			×			NOTE: The item is displayed, but it is not monitored
BSW IND BRIGHTNESS [Nothing/Bright/Nor- mal/Dark]	×				×		Indicates status of brightness of Blind Spot Warning/Blind Spot Intervention indicator
SL MAIN SW [On/Off]	×		×				Indicates [On/Off] status as judged from steering switch
PMAS SW [On/Off]	×						NOTE: The item is displayed, but it is not monitored
PMAS IND [On/Off]	×						NOTE: The item is displayed, but it is not monitored
FUNC ITEM(FEB) [On/Off]	×						Indicates systems which can be set to ON/OFF by selecting "Driver Aids" ⇒ "Emergency Assist" of the integral switch Forward Emergency Braking
FEB SELECT [On/Off]	×						Indicates an ON/OFF state of the FEB system. The FEB system can be set to ON/OFF by selecting "Driving Aids" ⇒ "Emergency Assist" of the integral switch
FEB SW [On/Off]	×						Indicates [On/Off] status of FEB system
G SENSOR SIGNAL [On/Off]	×						NOTE: The item is displayed, but it is not used
PMAS BUZZER REQ 1 [On/Off]	×						NOTE: The item is displayed, but it is not used
PMAS BUZZER REQ 2 [On/Off]	×						NOTE: The item is displayed, but it is not used

DIAGNOSIS SYSTEM (ADAS CONTROL UNIT)

< SYSTEM DESCRIPTION >

[ICC]

Monitored item [Unit]	ALL SIG	ALL SIG (ICC)	MAIN SIG (ICC)	MAIN SIG (LDW/LDP)	MAIN SIG (BSW/BSI)	MAIN SIG (BCI)	Description
PMAS BUZZER REQ 3 [On/Off]	×						NOTE: The item is displayed, but it is not used
SL TARGET VEHI- CLE SPEED [km/h]	×	×					Indicates set vehicle speed memorized in ADAS control unit
SL SET LAMP [On/Off]	×	×					Indicates [On/Off] status of speed limiter SET display output
SL LIMIT LAMP [On/Off]	×	×					Indicates [On/Off] status of speed limiter MAIN switch display out- put
ASCD CANCEL (LOW SPEED) [NON/CUT]	×	×					Indicates the vehicle cruise condition. • NON: Vehicle speed is maintained at the ASCD set speed. • CUT: Vehicle speed decreased to excessively low, and ASCD op- eration is cut off.
ASCD CANCEL (SPEED DIFF) [NON/CUT]	×	×					Indicates the vehicle cruise condition. • NON: Vehicle speed is maintained at the ASCD set speed. • CUT: Vehicle speed decreased to excessively low compared with the ASCD set speed, and ASCD operation is cut off.
KICK DOWN [On/Off]	×	×					Display Kick Down decision state. • On: Accelerator pedal is depressed • Off: Accelerator pedal is fully released

ACTIVE TEST

CAUTION:

- **Never perform “Active Test” while driving the vehicle.**
- **The “Active Test” cannot be performed when the following systems malfunction is displayed.**
 - ICC system
 - DCA
 - LDW
 - LDP
 - Blind Spot Warning
 - Blind Spot Intervention
 - BCI
- **The “Active Test” cannot be performed when the FEB warning lamp is illuminated.**
- **Shift the selector lever to “P” position, and then perform the test.**

Test item	Description
BRAKE ACTUATOR	Activates the brake by an arbitrary operation
ICC BUZZER	Sounds a buzzer used for following systems by arbitrarily operating ON/OFF <ul style="list-style-type: none"> • Intelligent Cruise Control (ICC) • Distance Control Assist (DCA) • Predictive Forward Collision Warning (PFCW) • Forward Emergency Brake (FEB)
METER LAMP	The MAIN switch indicator and FEB warning lamp can be illuminated by ON/OFF operations as necessary
STOP LAMP	The ICC brake hold relay can be operated by ON/OFF operations as necessary, and the stop lamp can be illuminated
ACTIVE PEDAL	The accelerator pedal actuator can be operated as necessary
DCA INDICATOR	The DCA system display can be illuminated by ON/OFF operations as necessary
LDP BUZZER	Sounds a buzzer used for following systems by arbitrarily operating ON/OFF <ul style="list-style-type: none"> • Lane Departure Warning (LDW) • Lane Departure Prevention (LDP) • Blind Spot Warning (BSW) • Blind Spot Intervention

DIAGNOSIS SYSTEM (ADAS CONTROL UNIT)

< SYSTEM DESCRIPTION >

[ICC]

Test item	Description
LDP ON IND	The LDP system display can be illuminated by ON/OFF operations as necessary
LANE DEPARTURE W/L	The LDW/LDP warning can be illuminated by ON/OFF operations as necessary
BSW/BSI WARNING INDICATOR	The BSW malfunction can be illuminated by ON/OFF operations as necessary
BSI ON INDICATOR	The Blind Spot Intervention system display can be illuminated by ON/OFF operations as necessary
LDW ON INDICATOR	The LDW system display can be illuminated by ON/OFF operations as necessary
LDP WARNING INDICATOR	The LDP malfunction can be illuminated by ON/OFF operations as necessary
LDW WARNING INDICATOR	The LDW malfunction can be illuminated by ON/OFF operations as necessary
BSW ON INDICATOR	The Blind Spot Warning system display can be illuminated by ON/OFF operations as necessary
BSI WARNING INDICATOR	The Blind Spot Intervention malfunction can be illuminated by ON/OFF operations as necessary

BRAKE ACTUATOR

NOTE:

The test can be performed only when the engine is running.

Test item	Operation	Description	"PRESS SENS" value
BRAKE ACTUATOR	MODE1	Transmits the brake fluid pressure control signal to the ABS actuator and electric unit (control unit) via chassis control module	10 bar
	MODE2		20 bar
	MODE3		30 bar
	Test start	Starts the tests of "MODE1", "MODE2" and "MODE3"	—
	Reset	Stops transmitting the brake fluid pressure control signal below to end the test	—
	End	Returns to the "SELECT TEST ITEM" screen	—

NOTE:

The test is finished in 10 seconds after starting

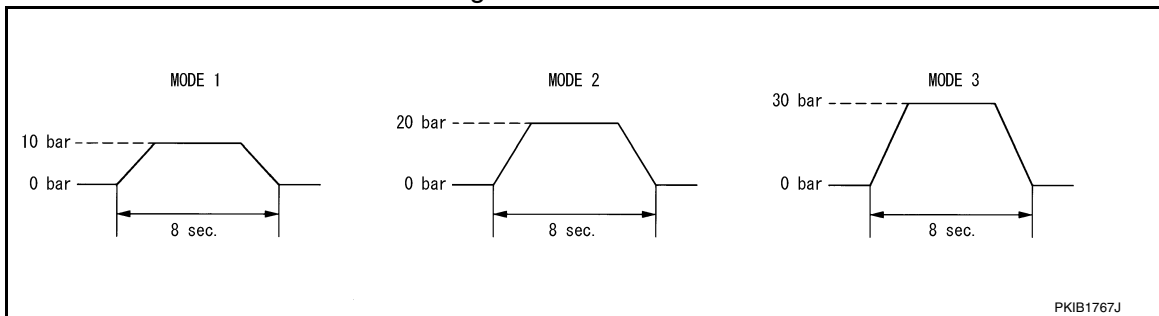

ICC BUZZER

Test item	Operation	Description	Operation sound
ICC BUZZER	MODE1	Transmits the buzzer output signals to the ADAS control unit 2 via ITS communication	Intermittent beep sound
	Test start	Starts the tests of "MODE1"	—
	Reset	Stops transmitting the buzzer output signal below to end the test	—
	End	Returns to the "SELECT TEST ITEM" screen	—

METER LAMP

NOTE:

The test can be performed only when the engine is running.

DIAGNOSIS SYSTEM (ADAS CONTROL UNIT)

< SYSTEM DESCRIPTION >

[ICC]

Test item	Operation	Description	
			<ul style="list-style-type: none"> • MAIN switch indicator • ICC system warning • FEB warning lamp
METER LAMP	Off	Stops sending the following signals to exit from the test <ul style="list-style-type: none"> • Meter display signal • FEB warning lamp signal 	OFF
	On	Transmits the following signals to the combination meter via CAN communication <ul style="list-style-type: none"> • Meter display signal • FEB warning lamp signal 	ON

STOP LAMP

Test item	Operation	Description	Stop lamp
STOP LAMP	Off	Stops transmitting the ICC brake hold relay drive signal below to end the test	OFF
	On	Transmits the ICC brake hold relay drive signal	ON

ACTIVE PEDAL

CAUTION:

- Shift the selector lever to “P” position, and then perform the test.
- Never depress the accelerator pedal excessively. (The engine speed may rise unexpectedly when finishing the test.)

NOTE:

- Depress the accelerator pedal to check when performing the test.
- The test can be performed only when the engine is running.

Test item	Operation	Description	Accelerator pedal operation
ACTIVE PEDAL	MODE1	Transmit the accelerator pedal feedback force control signal to the accelerator pedal actuator via ITS communication.	Constant with a force of 25 N for 8 seconds
	MODE2		Constant with a force of 15 N for 8 seconds
	MODE3		Change up to a force of 25 N for 8 seconds
	MODE4		Change up to a force of 15 N for 8 seconds
	Test start	Starts the tests of “MODE1”, “MODE2”, “MODE3” and “MODE4”	—
	Reset	Stops transmitting the accelerator pedal feedback force control signal below to end the test.	—
	End	Returns to the “SELECT TEST ITEM” screen	—

NOTE:

The test is finished in 10 seconds after starting

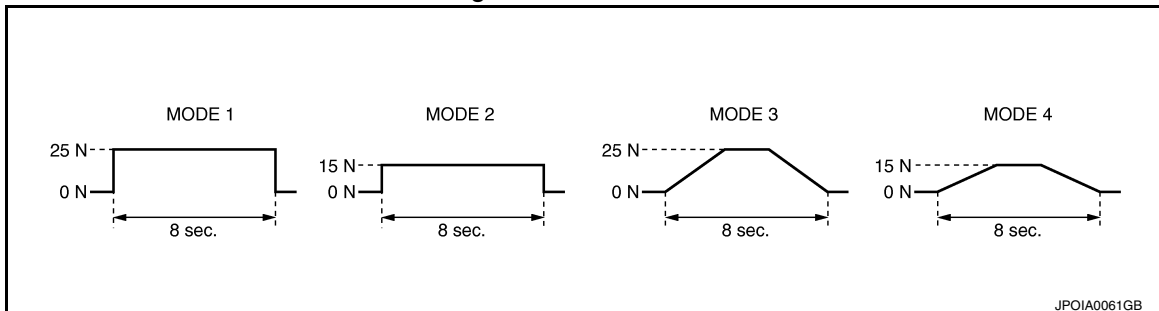

DCA INDICATOR

NOTE:

The test can be performed only when the engine is running.

A
B
C
D
E
F
G
H
I
J
K
L
M
N
P

CCS

DIAGNOSIS SYSTEM (ADAS CONTROL UNIT)

< SYSTEM DESCRIPTION >

[ICC]

Test item	Operation	Description	DCA system display
DCA INDICATOR	Off	Stops transmitting the meter display signal below to end the test	—
	On	Transmits the meter display signal to the combination meter via CAN communication	ON

LDP BUZZER

Test item	Operation	Description	Warning buzzer
LDP BUZZER	Off	Stops transmitting the warning buzzer signal below to end the test	—
	On	Transmits the warning buzzer signal to the warning buzzer	ON

LDP ON IND

Test item	Operation	Description	LDP system display (Green)
LDP ON IND	Off	Stops transmitting the meter display signal below to end the test	—
	On	Transmits the meter display signal to the combination meter via CAN communication	ON

LANE DEPARTURE W/L

Test item	Operation	Description	Lane departure system display (Yellow)
LANE DEPARTURE W/L	Off	Stops transmitting the meter display signal below to end the test	—
	On	Transmits the meter display signal to the combination meter via CAN communication	ON

BSW/BSI WARNING INDICATOR

Test item	Operation	Description	BSW malfunction (Yellow)
BSW/BSI WARNING INDICATOR	Off	Stops transmitting the meter display signal below to end the test	—
	On	Transmits the meter display signal to the combination meter via CAN communication	ON

BSI ON INDICATOR

Test item	Operation	Description	Blind Spot Intervention system display (Green)
BSI ON INDICATOR	Off	Stops transmitting the meter display signal below to end the test	—
	On	Transmits the meter display signal to the combination meter via CAN communication	ON

LDW ON INDICATOR

Test item	Operation	Description	LDW system display (White)
LDW ON INDICATOR	Off	Stops transmitting the meter display signal below to end the test	—
	On	Transmits the meter display signal to the combination meter via CAN communication	ON

DIAGNOSIS SYSTEM (ADAS CONTROL UNIT)

< SYSTEM DESCRIPTION >

[ICC]

LDP WARNING INDICATOR

Test item	Operation	Description	LDP malfunction (Yellow)
LDP WARNING INDICATOR	Off	Stops transmitting the meter display signal below to end the test	—
	On	Transmits the meter display signal to the combination meter via CAN communication	ON

LDW WARNING INDICATOR

Test item	Operation	Description	LDW malfunction (Yellow)
LDW WARNING INDICATOR	Off	Stops transmitting the meter display signal below to end the test	—
	On	Transmits the meter display signal to the combination meter via CAN communication	ON

BSW ON INDICATOR

Test item	Operation	Description	Blind Spot Warning system display (Yellow)
BSW ON INDICATOR	Off	Stops transmitting the meter display signal below to end the test	—
	On	Transmits the meter display signal to the combination meter via CAN communication	ON

BSI WARNING INDICATOR

Test item	Operation	Description	Blind Spot Intervention malfunction (Yellow)
BSI WARNING INDICATOR	Off	Stops transmitting the meter display signal below to end the test	—
	On	Transmits the meter display signal to the combination meter via CAN communication	ON

ECU IDENTIFICATION

Displays ADAS control unit parts number.

A
B
C
D
E
F
G
H
I
J
K
L
M
N
P

CCS

DIAGNOSIS SYSTEM (ADAS CONTROL UNIT 2)

< SYSTEM DESCRIPTION >

[ICC]

DIAGNOSIS SYSTEM (ADAS CONTROL UNIT 2)

CONSULT Function (ICC/ADAS 2)

INFOID:000000013965357

APPLICATION ITEMS

CONSULT performs the following functions via CAN communication using ADAS control unit 2.

Diagnosis mode	Description
Configuration	<ul style="list-style-type: none">The vehicle specification that is written in ADAS control unit can be displayed or storedThe vehicle specification can be written when ADAS control unit is replaced
Self Diagnostic Result	Displays the name of a malfunctioning system stored in the ADAS control unit
Data Monitor	Displays ADAS control unit input/output data in real time
Active Test	Enables an operational check of a load by transmitting a driving signal from the ADAS control unit to the load
ECU Identification	Displays ADAS control unit part number
CAN Diag Support Monitor	Displays a reception/transmission state of CAN communication and ITS communication

CONFIGURATION

Configuration includes functions as follows.

NOTE:

Models with FEB system only.

Function	Description
Read/Write Configuration	Before Replace ECU Allows the reading of vehicle specification written in ADAS control unit to store the specification in CONSULT.
	After Replace ECU Allows the writing of the vehicle information stored in CONSULT into the ADAS control unit.
Manual Configuration	Allows the writing of the vehicle specification into the ADAS control unit by hand.

SELF DIAGNOSTIC RESULT

Refer to [CCS-85, "DTC Index"](#).

NOTE:

- The details of time display are as per the following.
 - CRNT: A malfunction is detected now
 - PAST: A malfunction was detected in the past
- IGN counter is displayed on FFD (Freeze Frame Data).
 - 0: The malfunctions that are detected now
CAN communication system (U1000-01, U1010-49)
 - 1 - 39: It increases like 0 → 1 → 2 ... 38 → 39 after returning to the normal condition whenever the ignition switch OFF → ON. It returns to 0 when a malfunction is detected again in the process.
 - If it is over 39, it is fixed to 39 until the self-diagnosis results are erased.
 - Other than CAN communication system (Other than U1000-01, U1010-49)
 - 1 - 49: It increases like 0 → 1 → 2 ... 38 → 49 after returning to the normal condition whenever the ignition switch OFF → ON. It returns to 0 when a malfunction is detected again in the process.
 - If it is over 49, it is fixed to 49 until the self-diagnosis results are erased.

DATA MONITOR

NOTE:

The following table includes information (items) inapplicable to this vehicle. For information (items) applicable to this vehicle, refer to CONSULT display items.

DIAGNOSIS SYSTEM (ADAS CONTROL UNIT 2)

< SYSTEM DESCRIPTION >

[ICC]

Monitored item [Unit]	A-TEST I/O SIG	RADAR ICC (MAIN)	RADAR ICC (SUB)	FCW/FEB SIG	CAMERA ICC (ALL)	CAMERA ICC (MAIN)	LDW (MAIN)	BSW (MAIN)	BCI (MAIN)	EAP (MAIN)	Description
MAIN SW [On/Off]					x	x	x	x			Indicates [On/Off] status as judged from ICC steering switch
SET/COAST SW [On/Off]					x	x					Indicates [On/Off] status as judged from ICC steering switch
CANCEL SW [On/Off]					x	x					Indicates [On/Off] status as judged from ICC steering switch
RESUME/ACC SW [On/Off]					x	x					Indicates [On/Off] status as judged from ICC steering switch
DISTANCE SW [On/Off]					x						Indicates [On/Off] status as judged from ICC steering switch
CRUISE OPE [On/Off]					x	x					Indicates whether controlling or not (ON means "controlling")
BRAKE SW [On/Off]					x	x	x	x	x	x	Indicates [On/Off] status as judged from ICC brake switch signal (ECM transmits ICC brake switch signal through CAN communication)
STOP LAMP SW [On/Off]	x		x		x	x	x	x	x	x	Indicates [On/Off] status as judged from stop lamp switch signal (ECM transmits stop lamp switch signal through CAN communication)
IDLE SW [On/Off]					x				x	x	Indicates [On/Off] status of idle switch read from ADAS control unit through CAN communication (ECM transmits On/Off status through CAN communication)
SET DISTANCE [Short/Mid/Long]					x	x					Indicates set distance memorized in ADAS control unit
CRUISE LAMP [On/Off]			x		x	x					Indicates [On/Off] status of MAIN switch indicator output
OWN VHCL [On/Off]			x		x						NOTE: The item is displayed, but it is not monitored
VHCL AHEAD [On/Off]			x		x						Indicates [On/Off] status of vehicle ahead detection indicator output
ICC WARNING [On/Off]			x		x						Indicates [On/Off] status of ICC system warning lamp output
BA WARNING [On/Off]			x		x						Indicates [On/Off] status of FEB indicator lamp output
VHCL SPEED SE [km/h] or [mph]		x	x		x	x	x	x	x	x	Indicates vehicle speed calculated from ADAS control unit through CAN communication [ABS actuator and electric unit (control unit) transmits vehicle speed signal (wheel speed) through CAN communication]
SET VHCL SPD [km/h] or [mph]			x		x	x					Indicates set vehicle speed memorized in ADAS control unit
BUZZER O/P [On/Off]	x		x		x				x		Indicates [On/Off] status of ICC warning chime output
THRTL SENSOR [deg]		x			x	x				x	NOTE: The item is displayed, but it is not monitored
ENGINE RPM [rpm]		x			x					x	Indicates engine speed read from ADAS control unit through CAN communication (ECM transmits engine speed signal through CAN communication)

A
B
C
D
E
F
G
H
I
J
K
L
M
N
P

CCS

DIAGNOSIS SYSTEM (ADAS CONTROL UNIT 2)

< SYSTEM DESCRIPTION >

[ICC]

Monitored item [Unit]	A-TEST I/O SIG	RADAR ICC (MAIN)	RADAR ICC (SUB)	FCW/FEB SIG	CAMERA ICC (ALL)	CAMERA ICC (MAIN)	LDW (MAIN)	BSW (MAIN)	BCI (MAIN)	EAP (MAIN)	Description
WIPER SW [OFF/LOW/HIGH]					×						Indicates wiper [OFF/LOW/HIGH] status (BCM transmits front wiper request signal through CAN communication)
YAW RATE [deg/s]					×						NOTE: The item is displayed, but it is not monitored
RELEASE SW NO [On/Off]					×		×	×	×		NOTE: The item is displayed, but it is not monitored
RELEASE SW NC [On/Off]					×		×	×	×		NOTE: The item is displayed, but it is not monitored
STP LMP DRIVE [On/Off]	×		×		×	×				×	Indicates [On/Off] status of ICC brake hold relay drive output
D POSITION SW [On/Off]					×					×	Indicates [On/Off] status of "D" or "M" positions read from ADAS control unit through CAN communication; ON when position "D" or "M" (TCM transmits shift position signal through CAN communication).
NP RANGE SW [On/Off]			×		×					×	Indicates shift position signal read from ADAS control unit through CAN communication (TCM transmits shift position signal through CAN communication)
PKB SW [On/Off]					×					×	Parking brake switch status [On/Off] judged from the parking brake switch signal that ADAS control unit readout via CAN communication is displayed (combination meter transmits the parking brake switch signal via CAN communication)
PWR SUP MONI [V]	×		×		×	×				×	Indicates IGN voltage input by ADAS control unit
VHCL SPD AT [km/h] or [mph]		×			×					×	Indicates vehicle speed calculated from A/T vehicle speed sensor read from ADAS control unit through CAN communication (TCM transmits A/T vehicle speed sensor signal through CAN communication)
THRTL OPENING [%]					×	×			×	×	Indicates throttle position read from ADAS control unit through CAN communication (ECM transmits accelerator pedal position signal through CAN communication).
GEAR [1, 2, 3, 4, 5, 6, 7]			×		×					×	Indicates A/T gear position read from ADAS control unit through CAN communication (TCM transmits current gear position signal through CAN communication)
CLUTCH SW SIG [On/Off]					×	×					NOTE: The item is displayed, but it is not monitored
NP SW SIG [On/Off]					×	×					Indicates [On/Off] status as judged from park/neutral position switch signal (ECM transmits park/neutral position switch signal through CAN communication).
MODE SIG [OFF, ICC, ASCD]					×						Indicates the active mode from ICC or ASCD [conventional (fixed speed) cruise control mode]
SET DISP IND [On/Off]			×		×						Indicates [On/Off] status of SET switch indicator output

DIAGNOSIS SYSTEM (ADAS CONTROL UNIT 2)

< SYSTEM DESCRIPTION >

[ICC]

Monitored item [Unit]	A-TEST I/O SIG	RADAR ICC (MAIN)	RADAR ICC (SUB)	FCW/FEB SIG	CAMERA ICC (ALL)	CAMERA ICC (MAIN)	LDW (MAIN)	BSW (MAIN)	BCI (MAIN)	EAP (MAIN)	Description
DISTANCE [m]					×						Indicates the distance from the vehicle ahead
RELATIVE SPD [m/s]					×						Indicates the relative speed of the vehicle ahead
FCW SYSTEM ON [On/Off]					×	×					Indicates [On/Off] status of PFCW system
LDW SYSTEM ON [On/Off]							×				Indicates [On/Off] status of LDW system
LDW ON LAMP [On/Off]							×				Indicates [On/Off] status of LDW system display output
LANE DPRT W/L [On/Off]							×				Indicates [On/Off] status of LDW/LDP warning display (Yellow) output
BUZEROUTPUT [On/Off]							×				Indicates [On/Off] status of warning buzzer output
LDP) CAMERA LOST [Detect/Deviate/Both]							×	×			Indicates a lane marker detection state judged from a lane marker detection signal read by the ADAS control unit via ITS communication (Lane camera unit transmits a lane marker signal via ITS communication)
LDP) LANE UN-CLEAR [On/Off]							×	×			Indicates an ON/OFF state of the lane marker. The ON/OFF state is judged from a detected lane condition signal read by the ADAS control unit via ITS communication (The lane camera unit transmits a detected lane condition signal via ITS communication)
LDP) SHIFT POSITION [Off, P, R, N, D, M/T1 - 7]							×	×	×	×	Indicates shift position read from ADAS control unit through CAN communication (TCM transmits shift position signal through CAN communication)
LDP) TURN SIGNAL [OFF/LH/RH/LH&RH]							×	×			Indicates turn signal operation status read from ADAS control unit through CAN communication (BCM transmits turn indicator signal through CAN communication)
SIDE G [G]							×	×			Indicates lateral G acting on the vehicle. This lateral G is judged from a side G sensor signal read by ADAS control unit via CAN communication (The ABS actuator and electric unit (control unit) transmits a side G sensor signal via CAN communication)
FUNC ITEM (FCW) [On/Off]				×	×	×	×	×			Indicates systems which can be set to ON/OFF by selecting "Driver Aids" ⇒ "Emergency Assist" of the integral switch Forward Emergency Braking
FUNC ITEM (LDW) [On/Off]					×	×	×	×			Indicates systems which can be set to ON/OFF by selecting "Driver Aids" ⇒ "Lane" of the integral switch Lane Departure Warning
FUNC ITEM (BSW) [On/Off]					×	×	×	×			Indicates systems which can be set to ON/OFF by selecting "Driver Aids" ⇒ "Blind spot" of the integral switch Blind Spot Warning

A
B
C
D
E
F
G
H
I
J
K
L
M
N

CCS

P

DIAGNOSIS SYSTEM (ADAS CONTROL UNIT 2)

< SYSTEM DESCRIPTION >

[ICC]

Monitored item [Unit]	A-TEST I/O SIG	RADAR ICC (MAIN)	RADAR ICC (SUB)	FCW/FEB SIG	CAMERA ICC (ALL)	CAMERA ICC (MAIN)	LDW (MAIN)	BSW (MAIN)	BCI (MAIN)	EAP (MAIN)	Description
FCW SELECT [On/Off]				x	x	x	x	x			Indicates an ON/OFF state of the PFCW system. The PFCW system can be set to ON/OFF by selecting "Driving Aids" ⇒ "Emergency Assist" of the integral switch
LDW SELECT [On/Off]					x	x	x	x			Indicates an ON/OFF state of the LDW system. The LDW system can be set to ON/OFF by selecting "Driving Aids" ⇒ "Lane" of the integral switch
BSW SELECT [On/Off]					x	x	x	x			Indicates an ON/OFF state of the BSW system. The BSW system can be set to ON/OFF by selecting "Driving Aids" ⇒ "Blind spot" of the integral switch
WARN SYS SW [On/Off]				x	x	x	x	x			NOTE: The item is displayed, but it is not monitored
BSW/BSI WARN LMP [On/Off]								x			Indicates [On/Off] status of Blind Spot warning malfunction
BSI ON IND [On/Off]								x			Indicates [On/Off] status of Blind Spot Intervention system display
BSI/BSW [On/Off]								x			Indicates [On/Off] status of Blind Spot Intervention system
BSW SYSTEM ON [On/Off]								x			Indicates [On/Off] status of BSW system
BSW/CTA SW [On/Off]	x							x			NOTE: The item is displayed, but it is not monitored
BSW/CTA SW IND [On/Off]	x							x			NOTE: The item is displayed, but it is not monitored
BCI ON IND [On/Off]									x		NOTE: The item is displayed, but it is not monitored
BCI OFF IND [On/Off]									x		NOTE: The item is displayed, but it is not monitored
BCI WARNING IND [On/Off]									x		NOTE: The item is displayed, but it is not monitored
BCI HI TEMP WARN IND [On/Off]									x		NOTE: The item is displayed, but it is not monitored
BATTERY CIRCUIT OFF [On/Off]									x		NOTE: The item is displayed, but it is not used
LDW ON INDICATOR [On/Off]							x				Indicates [On/Off] status of LDW system ON display output
LDW WARNING INDICATOR [On/Off]							x				Indicates [On/Off] status of LDW system warning display output
SYSTEM CANCEL MESSAGE [NOREQ/SLIP/ SNOW/VDC OFF]			x		x	x					Indicates status of system cancel display output
CAMERA HI TEMP MSG [On/Off]							x				Indicates [On/Off] status of lane camera unit high temperature warning display output

DIAGNOSIS SYSTEM (ADAS CONTROL UNIT 2)

< SYSTEM DESCRIPTION >

[ICC]

Monitored item [Unit]	A-TEST I/O SIG	RADAR ICC (MAIN)	RADAR ICC (SUB)	FCW/FEB SIG	CAMERA ICC (ALL)	CAMERA ICC (MAIN)	LDW (MAIN)	BSW (MAIN)	BCI (MAIN)	EAP (MAIN)	Description
ITS SETTING ITEM(DCA) [On/Off]					×	×					Indicates the presence or absence of DCA system.
ITS SETTING ITEM(LDP) [On/Off]					×	×					Indicates the presence or absence of LDP system.
ITS SETTING ITEM(BSI) [On/Off]					×	×					Indicates the presence or absence of Blind Spot Intervention system.
BSI WARNING INDICATOR [On/Off]								×			Indicates [On/Off] status of Blind Spot Intervention warning display output
BSW ON INDICATOR [On/Off]								×			Indicates [On/Off] status of BSW system ON display output
SIDE RADAR BLOCK COND [On/Off]								×			Indicates [On/Off] status of side radar with dirt or foreign materials
LDW WARNING ALERT TIMING [Nothing/Early/Late]							×				NOTE: The item is displayed, but it is not monitored
BSW IND BRIGHTNESS [Nothing/Bright/Normal/Dark]								×			Indicates status of brightness of Blind Spot Warning/Blind Spot Intervention indicator
PMAS SW [On/Off]										×	NOTE: The item is displayed, but it is not monitored
PMAS IND [On/Off]										×	NOTE: The item is displayed, but it is not monitored
G SENSOR SIGNAL [On/Off]										×	NOTE: The item is displayed, but it is not monitored
PMAS BUZZER REQ 1 [On/Off]										×	NOTE: The item is displayed, but it is not monitored
PMAS BUZZER REQ 2 [On/Off]										×	NOTE: The item is displayed, but it is not monitored
PMAS BUZZER REQ 3 [On/Off]										×	NOTE: The item is displayed, but it is not monitored
EAP SW [On/Off]	×									×	NOTE: The item is displayed, but it is not monitored
EAP SW IND [On/Off]	×									×	NOTE: The item is displayed, but it is not monitored
RADAR COMMAND SIGNAL [Normal/Abnormal]		×									NOTE: The item is displayed, but it is not monitored
ICC SYSTEM ON [On/Off]		×									NOTE: The item is displayed, but it is not monitored
ICC AVAILABLE COND [On/Off]		×									NOTE: The item is displayed, but it is not monitored

A
B
C
D
E
F
G
H
I
J
K
L
M
N
P

CCS

DIAGNOSIS SYSTEM (ADAS CONTROL UNIT 2)

< SYSTEM DESCRIPTION >

[ICC]

Monitored item [Unit]	A-TEST I/O SIG	RADAR ICC (MAIN)	RADAR ICC (SUB)	FCW/FEB SIG	CAMERA ICC (ALL)	CAMERA ICC (MAIN)	LDW (MAIN)	BSW (MAIN)	BCI (MAIN)	EAP (MAIN)	Description
FEB AVAILABLE COND [On/Off]				×							NOTE: The item is displayed, but it is not monitored
FCW AVAILABLE COND [On/Off]				×							NOTE: The item is displayed, but it is not monitored
EBA AVAILABLE COND [On/Off]				×							NOTE: The item is displayed, but it is not monitored

ACTIVE TEST

Test item	Description
ADAS buzzer 2	Sounds a buzzer used for following systems by arbitrarily operating ON/OFF <ul style="list-style-type: none"> • Intelligent Cruise Control (ICC) • Distance Control Assist (DCA) • Predictive Forward Collision Warning (PFCW) • Forward Emergency Brake (FEB) • Blind Spot Warning (BSW) • Blind Spot Intervention
Vibration motor	Operate a steering vibration motor used for following systems by arbitrarily operating ON/OFF <ul style="list-style-type: none"> • Lane Departure Warning (LDW) • Lane Departure Prevention (LDP)

ADAS buzzer 2

Test item	Operation	Description	Warning buzzer
ADAS buzzer 2	On	Stops transmitting the buzzer output signal below to end the test	ON
	Off	Transmits the warning buzzer signal to the driver assistance warning buzzer	—
	End	Returns to the "SELECT TEST ITEM" screen	—

Vibration motor

Test item	Operation	Description	Warning buzzer
Vibration motor	On	Stops transmitting the motor operation signal below to end the test	ON
	Off	Transmits the motor operation signal to the steering vibration motor	—
	End	Returns to the "SELECT TEST ITEM" screen	—

ECU IDENTIFICATION

Displays ADAS control unit 2 parts number.

DIAGNOSIS SYSTEM (ICC SENSOR)

< SYSTEM DESCRIPTION >

[ICC]

DIAGNOSIS SYSTEM (ICC SENSOR)

CONSULT Function (LASER/RADAR)

INFOID:0000000013711797

APPLICATION ITEMS

CONSULT performs the following functions via CAN communication with ADAS control unit and the communication with ICC sensor.

Diagnosis mode	Description
Work Support	It can monitor the adjustment direction indication in order to perform the radar alignment operation smoothly
Self Diagnostic Result	Displays malfunctioning system memorized in ICC sensor
Data Monitor	Displays real-time input/output data of ICC sensor
ECU Identification	Displays ICC sensor part number
CAN Diag Support Monitor	The results of transmit/receive diagnosis of ITS communication can be read

WORK SUPPORT

Work support items	Description
MILLIWAVE RADAR ADJUST	Outputs millimeter waves, calculates dislocation of the millimeter waves, and indicates adjustment direction

Radar Alignment

Refer to [CCS-132, "Application Notice"](#).

SELF DIAGNOSTIC RESULT

Refer to [CCS-88, "DTC Index"](#).

NOTE:

- The details of time display are as per the following.
- 0: The malfunctions that are detected now
CAN communication system (U1000, U1010)
- 1 - 39: It increases like 0 → 1 → 2 ... 38 → 39 after returning to the normal condition whenever the ignition switch OFF → ON. It returns to 0 when a malfunction is detected again in the process.
- If it is over 39, it is fixed to 39 until the self-diagnosis results are erased.
Other than CAN communication system (Other than U1000, U1010)
- 1 - 49: It increases like 0 → 1 → 2 ... 38 → 49 after returning to the normal condition whenever the ignition switch OFF → ON. It returns to 0 when a malfunction is detected again in the process.
- If it is over 49, it is fixed to 49 until the self-diagnosis results are erased.

DATA MONITOR

NOTE:

The following table includes information (items) inapplicable to this vehicle. For information (items) applicable to this vehicle, refer to CONSULT display items.

Monitored item [Unit]	Description
VHCL SPEED SE [km/h] or [mph]	Vehicle speed judged from a vehicle speed signal read by the ICC sensor via ITS communication is displayed [ADAS control unit receives a vehicle speed signal from ABS actuator and electric unit (control unit) via CAN communication and transmits the calculated vehicle speed to ICC sensor via ITS communication]
YAW RATE [deg/s]	Indicates yaw rate read from ADAS control unit through ITS communication (ADAS control unit receives yaw rate signal from ABS actuator and electric unit (control unit) via CAN communication and transmits yaw rate calculated by the ADAS control unit) Yaw rate judged from a yaw rate signal read by ICC sensor via ITS communication is displayed [ADAS control unit receives a yaw rate signal from ABS actuator and electric unit (control unit) via CAN communication and transmits the calculated yaw rate to ICC sensor via ITS communication]
PWR SUP MONI [V]	Indicates IGN voltage input by ICC sensor

DIAGNOSIS SYSTEM (ICC SENSOR)

[ICC]

< SYSTEM DESCRIPTION >

Monitored item [Unit]	Description
DISTANCE [m]	Indicates the distance from the vehicle ahead
RELATIVE SPD [m/s]	Indicates the relative speed of the vehicle ahead
RADAR OFFSET [m]	NOTE: The item is indicated, but not used
RADAR HEIGHT [m]	NOTE: The item is indicated, but not used
STEERING ANGLE [deg]	The steering angle is displayed
STRG ANGLE SPEED [deg/s]	The steering angle speed is displayed
L/R ADJUST	The horizontal correction value of the radar is displayed
U/D ADJUST	The vertical correction value of the radar is displayed

ECU IDENTIFICATION

Displays ICC sensor parts number.

DIAGNOSIS SYSTEM (ACCELERATOR PEDAL ACTUATOR)

< SYSTEM DESCRIPTION >

[ICC]

DIAGNOSIS SYSTEM (ACCELERATOR PEDAL ACTUATOR)

CONSULT Function (ACCELERATOR PEDAL ACT)

INFOID:000000013965372

DESCRIPTION

CONSULT performs the following functions via CAN communication with ADAS control unit and the communication with accelerator pedal actuator.

Test mode	Function
Self Diagnostic Result	<ul style="list-style-type: none"> Displays malfunctioning system memorized in accelerator pedal actuator Displays the Freeze Frame Data when the malfunction is detected
DATA MONITOR	Displays real-time input/output data of accelerator pedal actuator
ACTIVE TEST	Enables operation check of electrical loads by sending driving signal to them
ECU Identification	Displays accelerator pedal actuator parts number
CAN Diag Support Monitor	The results of transmit/receive diagnosis of ITS communication can be read

SELF DIAGNOSTIC RESULT

Self Diagnostic Result

Refer to [CCS-91, "DTC Index"](#).

FFD (Freeze Frame Data)

The accelerator pedal actuator records the following data when the malfunction is detected.

Freeze Frame Data item [Unit]	Description
TGT FBK FRC [N]	It displays the target accelerator pedal actuation force that the accelerator pedal actuator read out from the accelerator pedal feedback force control signal received via ITS communication at the time when the malfunction is detected
TGT MOT POSI [%]	It displays the target motor position that the accelerator pedal actuator read out from the accelerator pedal feedback force control signal received via ITS communication at the time when the malfunction is detected
ACT MOT POSI [%]	It displays the integrated motor position that the accelerator pedal actuator read out at the time when the malfunction is detected
AP OPEN [%]	It displays the accelerator pedal position signal that the accelerator pedal actuator read out via ITS communication at the time when the malfunction is detected
APA TEMP [°C]	It displays the integrated motor temperature that the accelerator pedal actuator read out at the time when the malfunction is detected
APA CURRENT [A]	It displays the integrated motor consumption current that the accelerator pedal actuator read out at the time when the malfunction is detected
APA PWR [V]	It displays the power supply voltage that the accelerator pedal actuator read out at the time when the malfunction is detected
APA OPE STATS [On/Off]	It displays the activation permission status of accelerator pedal actuator at the time when the malfunction is detected
APA STATS [READY/NG/TP NG/INIT]	It displays the condition of accelerator pedal actuator at the time when the malfunction is detected
ODO/TRIP METER	Total mileage (Odometer value) of the moment a particular.

DATA MONITOR

NOTE:

The following table includes information (items) inapplicable to this vehicle. For information (items) applicable to this vehicle, refer to CONSULT display items.

DIAGNOSIS SYSTEM (ACCELERATOR PEDAL ACTUATOR)

< SYSTEM DESCRIPTION >

[ICC]

Monitor item [Unit]	FUNCTION DESCRIPTION
TGT FBK FRC [N]	It displays the target accelerator pedal actuation force that the accelerator pedal actuator read out from the accelerator pedal feedback force control signal received via ITS communication (The ADAS control unit transmits the accelerator pedal feedback force control signal via ITS communication)
TGT MOT POSI [%]	It displays the target motor position that the accelerator pedal actuator read out from the accelerator pedal feedback force control signal received via ITS communication (The ADAS control unit transmits the accelerator pedal feedback force control signal via ITS communication)
ACT MOT POSI [%]	It displays the integrated motor position that the accelerator pedal actuator read out
AP OPEN [%]	It displays the accelerator pedal position signal that the accelerator pedal actuator read out via ITS communication (The ADAS control unit transmits with ITS communication the accelerator pedal position signal that is received from ECM via CAN communication)
APA TEMP [°C]	It displays the accelerator pedal actuator integrated motor temperature
APA CURRENT [A]	It displays the accelerator pedal actuator integrated motor consumption current
APA PWR [V]	It displays the power supply voltage that the accelerator pedal actuator read out
APA OPE STATS [On/Off]	It displays the activation permission status of accelerator pedal actuator
APA STATS [READY/NG/TP NG/INIT]	It displays the condition of accelerator pedal actuator

ACTIVE TEST

CAUTION:

Never perform ACTIVE TEST while driving the vehicle.

NOTE:

The active test cannot be performed when the ICC system warning lamp is illuminated.

Item list

Active test item	Description
ACCELERATOR PEDAL ACTUATOR TEST1	Drive the accelerator pedal actuator and generate the constant accelerator pedal actuation force
ACCELERATOR PEDAL ACTUATOR TEST2	Drive the accelerator pedal actuator and generate the vibration

ACCELERATOR PEDAL ACTUATOR TEST 1

NOTE:

Check the accelerator pedal by depressing when performing the test.

Active test item	Operation	Description
ACCELERATOR PEDAL ACTUATOR TEST1	STOP	Finish the test
	START	Generate the constant accelerator pedal actuation force for accelerator pedal

ACCELERATOR PEDAL ACTUATOR TEST 2

NOTE:

Check the accelerator pedal by depressing when performing the test.

Active test item	Operation	Description
ACCELERATOR PEDAL ACTUATOR TEST 2	STOP	Finish the test
	START	Generate the vibration for accelerator pedal

ECU IDENTIFICATION

Displays accelerator pedal assembly parts number.

ADAS CONTROL UNIT

< ECU DIAGNOSIS INFORMATION >

[ICC]

ECU DIAGNOSIS INFORMATION

ADAS CONTROL UNIT

Reference Value

INFOID:0000000013965358

VALUES ON THE DIAGNOSIS TOOL

NOTE:

The following table includes information (items) inapplicable to this vehicle. For information (items) applicable to this vehicle, refer to CONSULT display items.

Monitor item	Condition		Value/Status
MAIN SW	Ignition switch ON	When MAIN switch is pressed	On
		When MAIN switch is not pressed	Off
SET/COAST SW	Ignition switch ON	When SET/COAST switch is pressed	On
		When SET/COAST switch is not pressed	Off
CANCEL SW	Ignition switch ON	When CANCEL switch is pressed	On
		When CANCEL switch is not pressed	Off
RESUME/ACC SW	Ignition switch ON	When RESUME/ACCELERATE switch is pressed	On
		When RESUME/ACCELERATE switch is not pressed	Off
DISTANCE SW	Ignition switch ON	When DISTANCE switch is pressed	On
		When DISTANCE switch is not pressed	Off
CRUISE OPE	Drive the vehicle and activate the vehicle-to-vehicle distance control mode	When ICC system is controlling	On
		When ICC system is not controlling	Off
BRAKE SW	Ignition switch ON	When brake pedal is depressed	Off
		When brake pedal is not depressed	On
STOP LAMP SW	Ignition switch ON	When brake pedal is depressed	On
		When brake pedal is not depressed	Off
IDLE SW	Engine running	Idling	On
		Except idling (depress accelerator pedal)	Off
SET DISTANCE	<ul style="list-style-type: none"> • Start the engine and turn the ICC system ON • Press the DISTANCE switch to change the vehicle-to-vehicle distance setting 	When set to "long"	Long
		When set to "middle"	Mid
		When set to "short"	Short
CRUISE LAMP	Start the engine and press MAIN switch	ICC system ON (MAIN switch indicator ON)	On
		ICC system OFF (MAIN switch indicator OFF)	Off
OWN VHCL	NOTE: The item is indicated, but not monitored		Off
VHCL AHEAD	Drive the vehicle and activate the vehicle-to-vehicle distance control mode	When a vehicle ahead is detected (vehicle ahead detection indicator ON)	On
		When a vehicle ahead is not detected (vehicle ahead detection indicator OFF)	Off
ICC WARNING	Start the engine and press MAIN switch	When ICC system is malfunctioning (ICC system malfunction ON)	On
		When ICC system is normal (ICC system malfunction OFF)	Off

A
B
C
D
E
F
G
H
I
J
K
L
M
N
P

CCS

ADAS CONTROL UNIT

< ECU DIAGNOSIS INFORMATION >

[ICC]

Monitor item	Condition		Value/Status
VHCL SPEED SE	While driving		Displays the vehicle speed calculated by ADAS control unit
SET VHCL SPD	While driving	When vehicle speed is set	Displays the set vehicle speed
BUZZER O/P	Engine running	When the buzzer of the following system operates <ul style="list-style-type: none"> • Vehicle-to-vehicle distance control mode • DCA system • PFCW system • FEB system 	On
		When the buzzer of the following system not operates <ul style="list-style-type: none"> • Vehicle-to-vehicle distance control mode • DCA system • PFCW system • FEB system 	Off
THRTL SENSOR	NOTE: The item is indicated, but not monitored		0.0
ENGINE RPM	Engine running		Equivalent to tachometer reading
WIPER SW	Ignition switch ON	Wiper not operating	Off
		Wiper LO operation	Low
		Wiper HI operation	High
YAW RATE	NOTE: The item is indicated, but not monitored		0.0
BA WARNING	Engine running	FEB OFF indicator lamp ON <ul style="list-style-type: none"> • When FEB system is malfunctioning • When FEB system is turned to OFF 	On
		FEB OFF indicator lamp OFF <ul style="list-style-type: none"> • When FEB system is normal • When FEB system is turned to ON 	Off
RELEASE SW NO	NOTE: The item is indicated, but not monitored		—
RELEASE SW NC	NOTE: The item is indicated, but not monitored		—
STP LMP DRIVE	Drive the vehicle and activate the vehicle-to-vehicle distance control mode	When ICC brake hold relay is activated	On
		When ICC brake hold relay is not activated	Off
PRESS SENS	NOTE: The item is indicated, but not monitored		—
D RANGE SW	Engine running	When the selector lever is in "D" position or manual mode	On
		When the selector lever is in any position other than "D" or manual mode	Off
NP RANGE SW	Engine running	When the selector lever is in "N", "P" position	On
		When the selector lever is in any position other than "N", "P"	Off
PKB SW	Ignition switch ON	When the parking brake is applied	On
		When the parking brake is released	Off
PWR SUP MONI	Engine running		Power supply voltage value of ADAS control unit

ADAS CONTROL UNIT

< ECU DIAGNOSIS INFORMATION >

[ICC]

Monitor item	Condition		Value/Status
VHCL SPD AT	While driving		Value of A/T vehicle speed sensor signal
THRTL OPENING	Engine running	Depress accelerator pedal	Displays the throttle position
GEAR	While driving		Displays the gear position
MODE SIG	Start the engine and press MAIN switch	When ICC system is deactivated	Off
		When vehicle-to-vehicle distance control mode is activated	ICC
		When conventional (fixed speed) cruise control mode is activated	ASCD
SET DISP IND	<ul style="list-style-type: none"> • Drive the vehicle and activate the conventional (fixed speed) cruise control mode • Press SET/COAST switch 	SET switch indicator ON	On
		SET switch indicator OFF	Off
DISTANCE	Drive the vehicle and activate the vehicle-to-vehicle distance control mode	When a vehicle ahead is detected	Displays the distance from the preceding vehicle
		When a vehicle ahead is not detected	0.0
RELATIVE SPD	Drive the vehicle and activate the vehicle-to-vehicle distance control mode	When a vehicle ahead is detected	Displays the relative speed.
		When a vehicle ahead is not detected	0.0
DYNA ASIST SW	Ignition switch ON	When dynamic driver assistance switch is pressed	On
		When dynamic driver assistance switch is not pressed	Off
DCA ON IND	Start the engine and press dynamic driver assistance switch (When DCA setting is ON)	DCA system OFF	Off
		DCA system ON	On
DCA VHL AHED	Drive the vehicle and activate the DCA system	When a vehicle ahead is not detected (vehicle ahead detection indicator OFF)	Off
		When a vehicle ahead is detected (vehicle ahead detection indicator ON)	On
APA TEMP	Engine running		Display the accelerator pedal actuator integrated motor temperature
FCW MAIN SW	NOTE: The item is indicated, but not monitored		—
APA PWR	Ignition switch ON		Power supply voltage value of accelerator pedal actuator
NAVI-ICC DISP	NOTE: The item is indicated, but not monitored		Off
LDW SYSTEM ON	Ignition switch ON	When the LDW system is ON	On
		When the LDW system is OFF	Off
LANE DPRT W/L	Drive the vehicle and activate the LDW system or LDP system	Lane departure warning lamp ON	On
		Lane departure warning lamp OFF	Off

A
B
C
D
E
F
G
H
I
J
K
L
M
N
P

CCS

ADAS CONTROL UNIT

< ECU DIAGNOSIS INFORMATION >

[ICC]

Monitor item	Condition		Value/Status
LDW BUZER OUT-PUT	Drive the vehicle and activate the LDW/LDP system or Blind Spot Warning/Blind Spot Intervention system	When the buzzer of the following system operates • LDW/LDP system • Blind Spot Warning/Blind Spot Intervention system	On
		When the buzzer of the following system does not operate • LDW/LDP system • Blind Spot Warning/Blind Spot Intervention system	Off
LDP SYSTEM ON	Start the engine and press dynamic driver assistance switch (When LDP system setting is ON)	When the LDP system is ON	On
		When the LDP system is OFF	Off
WARN REQ	Drive the vehicle and activate the LDP system	Lane departure warning is operating	On
		Lane departure warning is not operating	Off
READY signal	Start the engine and press dynamic driver assistance switch (When LDP system setting is ON)	When the LDP system is ON	On
		When the LDP system is OFF	Off
Camera lost	Drive the vehicle and activate the LDW system, LDP system or Blind Spot Intervention system	Both side lane markers are detected	Detect
		Deviate side lane marker is lost	Deviate
		Both side lane markers are lost	Both
Lane unclear	While driving	Lane marker is unclear	On
		Lane marker is clear	Off
STATUS signal	Drive the vehicle and activate the LDP system	When the LDP system is ON	Stnby
		When the LDP system is operating	Warn
		When the LDP system is canceled	Cancl
		When the LDP system is OFF	Off
Shift position	<ul style="list-style-type: none"> • Engine running • While driving 		Displays the shift position
Turn signal	Turn signal lamps OFF		Off
	Turn signal lamp LH blinking		LH
	Turn signal lamp RH blinking		RH
	Turn signal lamp LH and RH blinking		LH&RH
SIDE G	While driving	Vehicle turning right	Negative value
		Vehicle turning left	Positive value
FUNC ITEM (FCW)	Engine running	"Forward Emergency Braking" set with the integral switch is ON	On
		"Forward Emergency Braking" set with the integral switch is OFF	Off
FUNC ITEM (LDW)	Engine running	"Lane Departure Warning" set with the integral switch is ON	On
		"Lane Departure Warning" set with the integral switch is OFF	Off
FUNC ITEM (BSW)	Engine running	"Blind Spot Warning" set with the integral switch is ON	On
		"Blind Spot Warning" set with the integral switch is OFF	Off
FUNC ITEM (NV-ICC)	NOTE: The item is indicated, but not monitored		Off
FUNC ITEM (NV-DCA)	NOTE: The item is indicated, but not monitored		Off

ADAS CONTROL UNIT

< ECU DIAGNOSIS INFORMATION >

[ICC]

Monitor item	Condition		Value/Status
DCA SELECT	Ignition switch ON	"Distance Control Assist" set with the integral switch is ON	On
		"Distance Control Assist" set with the integral switch is OFF	Off
LDP SELECT	Ignition switch ON	"Lane Departure Intervention" set with the integral switch is ON	On
		"Lane Departure Intervention" set with the integral switch is OFF	Off
BSI SELECT	Ignition switch ON	"Blind Spot Intervention" set with the integral switch is ON	On
		"Blind Spot Intervention" set with the integral switch is OFF	Off
FCW SELECT	Ignition switch ON	"Forward Emergency Braking" set with the integral switch is ON	On
		"Forward Emergency Braking" set with the integral switch is OFF	Off
LDW SELECT	Ignition switch ON	"Lane Departure Warning" set with the integral switch is ON	On
		"Lane Departure Warning" set with the integral switch is OFF	Off
BSW SELECT	Ignition switch ON	"Blind Spot Warning" set with the integral switch is ON	On
		"Blind Spot Warning" set with the integral switch is OFF	Off
NAVI ICC SELECT	NOTE: The item is indicated, but not monitored		Off
NAVI DCA SELECT	NOTE: The item is indicated, but not monitored		Off
DRIVE MODE STATS	Ignition switch ON	When drive mode select switch position is STANDARD	STD
		When drive mode select switch position is in SPORT	SPORT
		When drive mode select switch position is in ECO	ECO
		When drive mode select switch position is in SNOW	SNOW
		When drive mode select switch position is in PERSONAL	STD
		A signal other than those above is input	ERROR
BSW/BSI WARN LMP	Ignition switch ON	When the BSW system is malfunctioning	On
		When the BSW system is normal	Off
BSI ON IND	Ignition switch ON	Blind Spot Intervention warning ON	On
		Blind Spot Intervention warning OFF	Off
BSW SYSTEM ON	Ignition switch ON	When the BSW system is ON	On
		When the BSW system is OFF	Off
BSI SYSTEM ON	Start the engine and press dynamic driver assistance switch (When Blind Spot Intervention system setting is ON)	When the Blind Spot Intervention system is ON	On
		When the Blind Spot Intervention system is OFF	Off
FCW SYSTEM ON	Engine running	When the FEB/PFCW system is ON	On
		When the FEB/PFCW system is OFF	Off
BCI SYSTEM ON	Engine running	When the BCI system is ON	On
		When the BCI system is OFF	Off
BATTERY CIRCUIT OFF	NOTE: The item is indicated, but not used		Off

A

B

C

D

E

F

G

H

I

J

K

L

M

N

CCS

P

ADAS CONTROL UNIT

< ECU DIAGNOSIS INFORMATION >

[ICC]

Monitor item	Condition		Value/Status
LDP WARNING INDICATOR	Engine running	When the LDP system is malfunctioning	On
		When the LDP system is normal	Off
LDW ON INDICATOR	Ignition switch ON	LDW system display ON	On
		LDW system display OFF	Off
LDW WARNING INDICATOR	Ignition switch ON	When the LDW system is malfunctioning	On
		When the LDW system is normal	Off
SYSTEM CANCEL MESSAGE	Ignition switch ON	When the vehicle is normal	NOREQ
		When the wheel is slipping	SLIP
		When the drive mode selector is SNOW mode	SNOW
		When the VDC is OFF	VDC OFF
CAMERA HI TEMP MSG	Ignition switch ON	Lane camera unit high temperature warning display ON	On
		Lane camera unit high temperature warning display OFF	Off
ITS SETTING ITEM(DCA)	Ignition switch ON		On
ITS SETTING ITEM(LDP)	Ignition switch ON		On
ITS SETTING ITEM(BSI)	Ignition switch ON		On
BSI WARNING INDICATOR	Engine running	When the Blind Spot Intervention is malfunctioning	On
		When the Blind Spot Intervention is normal	Off
BSW ON INDICATOR	Ignition switch ON	BSW system display ON	On
		BSW system display OFF	Off
SIDE RADAR BLOCK COND	Ignition switch ON	Front bumper or side radar is dirty	On
		Front bumper and side radar is clean	Off
LDW WARNING ALERT TIMING	Ignition switch ON	LDW system OFF	Nothing
		Lane departure warning timing is early setting	Early
		Lane departure warning timing is late setting	Late
BSW IND BRIGHTNESS	Ignition switch ON	BSW system OFF	Nothing
		Blind Spot Warning/Blind Spot Intervention indicator brightness bright	Bright
		Blind Spot Warning/Blind Spot Intervention indicator brightness normal	Normal
		Blind Spot Warning/Blind Spot Intervention indicator brightness dark	Dark
SL MAIN SW	Engine running	When speed limiter MAIN switch is pressed	On
		When speed limiter MAIN switch is not pressed	Off
PMAS SW	NOTE: The item is indicated, but not used		—
PMAS IND	NOTE: The item is indicated, but not used		—
FUNC ITEM (FEB)	Engine running	"Forward Emergency Braking" set with the integral switch is ON	On
		"Forward Emergency Braking" set with the integral switch is OFF	Off
FEB SELECT	Ignition switch ON	"Forward Emergency Braking" set with the integral switch is ON	On
		"Forward Emergency Braking" set with the integral switch is OFF	Off

ADAS CONTROL UNIT

< ECU DIAGNOSIS INFORMATION >

[ICC]

Monitor item	Condition		Value/Status
FEB SW	Engine running	FEB system ON	On
		FEB system OFF	Off
G SENSOR SIGNAL	NOTE: The item is indicated, but not used		—
PMAS BUZZER REQ 1	NOTE: The item is indicated, but not used		—
PMAS BUZZER REQ 2	NOTE: The item is indicated, but not used		—
PMAS BUZZER REQ 3	NOTE: The item is indicated, but not used		—
SL TARGET VEHICLE SPEED	While driving	When vehicle speed is set	Displays the set vehicle speed
SL SET LAMP	<ul style="list-style-type: none"> • Drive the vehicle and activate the speed limiter • Press speed limiter MAIN switch 	Speed limiter SET indicator ON	On
		Speed limiter SET indicator OFF	Off
SL LIMIT LAMP	<ul style="list-style-type: none"> • Drive the vehicle and activate the speed limiter • Press speed limiter MAIN switch 	Speed limiter system ON	On
		Speed limiter system OFF	Off
ASCD CANCEL (LOW SPEED)	Drive the vehicle and activate the ASCD	ASCD cancelled by low vehicle speed	On
		Other than above	Off
ASCD CANCEL (SPEED DIFF)	Drive the vehicle and activate the ASCD	ASCD cancelled by difference between set speed and vehicle speed	On
		Other than above	Off
KICK DOWN	Drive the vehicle and activate the speed limiter	When accelerator pedal is full depressed	On
		Other than above	Off

TERMINAL LAYOUT

PHYSICAL VALUES

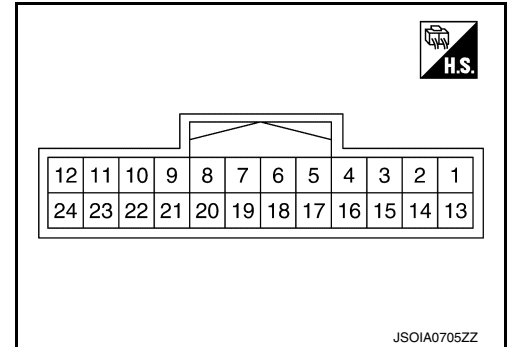

Terminal No. (Wire color)		Description		Condition	Standard value	Reference value
+	-	Signal name	Input/Output			
1 (L)	—	CAN -H	—	—	—	—
2 (R)	—	CAN -L	—	—	—	—
5 (B)	Ground	Ground	—	Ignition switch ON	0 - 0.1 V	Approx. 0 V

ADAS CONTROL UNIT

< ECU DIAGNOSIS INFORMATION >

[ICC]

Terminal No. (Wire color)		Description		Condition		Standard value	Reference value
+	-	Signal name	Input/ Output				
6 (L)	—	ITS communication-H	—	—		—	—
7 (P)		ITS communication-L	—	—		—	—
8 (L)		Chassis communication-H	—	—		—	—
9 (R)		Chassis communication-L	—	—		—	—
12 (GR) ^{*1} (G) ^{*2}	5 (B)	Ignition power supply	Input	Ignition switch ON	—	10 - 16 V	Battery voltage
17 (V)		ICC brake hold relay drive signal	Output	Ignition switch ON	— At "STOP LAMP" test of "Active test"	10 - 16 V 0 - 0.1 V	Approx. 12 V Approx. 0 V
23 (Y)		ICC/ASCD steering switch signal ground	—	Ignition switch ON		0 - 0.1 V	Approx. 0 V
24 ^{*3} (SB)	23 ^{*3} (Y)	ICC steering switch signal	Input	Ignition switch ON	ICC steering switch: OFF	4.1 - 4.3 V	Approx. 4.3 V
					CANCEL switch: Pressed	1.1 - 1.6	Approx. 1.3 V
					RESUME/ACCELERATE switch: Pressed	3.5 - 3.7 V	Approx. 3.7 V
					SET/COAST switch: Pressed	2.8 - 3.1 V	Approx. 3.0 V
					DISTANCE switch: Pressed	2.0 - 2.4 V	Approx. 2.2 V
24 ^{*4} (SB)	23 ^{*4} (Y)	ASCD steering switch signal	Input	Ignition switch ON	ASCD steering switch: OFF	3.8 - 4.3 V	Approx. 4.0 V
					CANCEL switch: Pressed	0.8 - 1.3 V	Approx. 1.0 V
					SET/COAST switch: Pressed	1.8 - 2.2 V	Approx. 2.0 V
					RESUME/ACCELERATE switch: Pressed	2.8 - 3.1 V	Approx. 3.0 V

NOTE:

- *1: VR30DDTT
- *2: 2.0 TURBO GASOLINE ENGINE
- *3: Used only in with ICC.
- *4: Used only in without ICC.

Fail-safe (ADAS Control Unit)

INFOID:0000000013965359

If a malfunction occurs in each system, ADAS control unit cancels each control, sounds a beep, and turns ON the warning or indicator lamp.

ADAS CONTROL UNIT

< ECU DIAGNOSIS INFORMATION >

[ICC]

System	Buzzer	Warning lamp/Warning display	Description
Vehicle-to-vehicle distance control mode	High-pitched tone	ICC system warning	Cancel
Conventional (fixed speed) cruise control mode	High-pitched tone	ICC system warning	Cancel
Forward Emergency Braking (FEB)	High-pitched tone	<ul style="list-style-type: none"> • FEB warning lamp • Warning systems indicator (Forward position: Yellow) 	Cancel
Predictive Forward Collision Warning (PFCW)	High-pitched tone	Warning systems indicator (Forward position: Yellow)	Cancel
Distance Control Assist (DCA)	High-pitched tone	Warning systems indicator (Forward position: Yellow)	Cancel
Blind Spot Warning (BSW)	—	Warning systems indicator (Blind spot position: Yellow)	Cancel
Back-up Collision Intervention (BCI)	High-pitched tone	BCI system warning	Cancel

DTC Inspection Priority Chart

INFOID:000000013965360

If multiple DTCs are detected simultaneously, check them one by one depending on the following DTC inspection priority chart.

Priority	Detected items (DTC)
1	<ul style="list-style-type: none"> • U1507: LOST COMM (SIDE RDR R) • U1508: LOST COMM (SIDE RDR L)
2	<ul style="list-style-type: none"> • C1A0A: CONFIG UNFINISHED • U1000: CAN COMM CIRCUIT • U1010: CONTROL UNIT (CAN)
3	<ul style="list-style-type: none"> • C1B00: CAMERA UNIT MALF • C1F02: APA C/U MALF • C1B53: SIDE RDR R MALF • C1B54: SIDE RDR L MALF • C1B84: DIST SEN MALFUNCTION

CCS

ADAS CONTROL UNIT

< ECU DIAGNOSIS INFORMATION >

[ICC]

Priority	Detected items (DTC)	
4	<ul style="list-style-type: none"> • C1A01: POWER SUPPLY CIR • C1A02: POWER SUPPLY CIR 2 • C1A04: ABS/TCS/VDC CIRC • C1A05: BRAKE SW/STOP L SW • C1A06: OPERATION SW CIRC • C1A13: STOP LAMP RLY FIX • C1A14: ECM CIRCUIT • C1A24: NP RANGE • C1A26: ECD MODE MALF • C1A27: ECD PWR SUPPLY CIR • C1A33: CAN TRANSMISSION ERR • C1A34: COMMAND ERROR • C1A35: APA CIR • C1A36: APA CAN COMM CIR • C1A37: APA CAN CIR 2 • C1A38: APA CAN CIR 1 • C1A39: STRG SEN CIR • C1B01: CAM AIMING INCOMP • C1B03: CAM ABNRML TMP DETCT • C1B5D: FEB OPE COUNT LIMIT • C1B56: SONAR CIRCUIT • C1B59: CCM CIRCUIT • C1B82: DIST SEN OFF-CENTER • C1B85: DIST SEN ABNORMAL TEMP • C1F01: APA MOTOR MALF • C1F05: APA PWR SUPPLY CIR 	<ul style="list-style-type: none"> • U0121: VDC CAN CIR 2 • U0126: STRG SEN CAN CIR 1 • U0235: ICC SENSOR CAN CIRC 1 • U0401: ECM CAN CIR 1 • U0402: TCM CAN CIR 1 • U0415: VDC CAN CIR 1 • U0424: HVAC CAN CIR 1 • U0428: STRG SEN CAN CIR 2 • U1500: CAM CAN CIR 2 • U1501: CAM CAN CIR 1 • U1502: ICC SEN CAN COMM CIR • U1503: SIDE RDR L CAN CIR 2 • U1504: SIDE RDR L CAN CIR 1 • U1505: SIDE RDR R CAN CIR 2 • U1506: SIDE RDR R CAN CIR 1 • U150B: ECM CAN CIRC 3 • U150C: VDC CAN CIRC 3 • U150D: TCM CAN CIRC 3 • U150E: BCM CAN CIRC 3 • U150F: AV CAN CIRC 3 • U1512: HVAC CAN CIRC 3 • U1513: METER CAN CIRC 3 • U1514: STRG SEN CAN CIRC 3 • U1515: ICC SENSOR CAN CIRC 3 • U1516: CAM CAN CIRC 3 • U1517: APA CAN CIRC 3 • U1518: SIDE RDR L CAN CIRC 3 • U1519: SIDE RDR R CAN CIRC 3 • U1521: SONAR CAN COMMUNICATION 2 • U1522: SONAR CAN COMMUNICATION 1 • U1523: SONAR CAN COMMUNICATION 3 • U1524: AVM CAN COMMUNICATION 1 • U1525: AVM CAN COMMUNICATION 3 • U1527: CCM CAN CIR 1 • U153F: CCM CAN CIR 2 • U1530: DR ASSIST BUZZER CAN CIR 1 • U1540: DAST 3 CAN CIR 1 • U1541: DAST 3 CAN CIR 2
5	<ul style="list-style-type: none"> • C1A03: VHCL SPEED SE CIRC 	
6	<ul style="list-style-type: none"> • C1A15: GEAR POSITION 	
7	<ul style="list-style-type: none"> • C1A00: CONTROL UNIT 	

ADAS CONTROL UNIT

< ECU DIAGNOSIS INFORMATION >

[ICC]

DTC Index

INFOID:000000013965361

Systems for fail-safe

- A: Vehicle-to-vehicle distance control mode
- B: Conventional (fixed speed) cruise control mode
- C: Distance Control Assist (DCA)
- D: Forward Emergency Braking (FEB)
- E: Predictive Forward Collision Warning (PFCW)
- F: Blind Spot Warning (BSW)/Blind Spot Intervention (Without Active Lane control)
- G: Back-up Collision Intervention (BCI)
- H: Lane Departure Warning (LDW)/Lane Departure Prevention (LDP)
- I: Automatic Speed Control Device (ASCD) (Without ICC)

DTC		CONSULT display	Fail-safe	Reference
CONSULT	On board display		System	
NO DTC IS DETECTED. FURTHER TESTING MAY BE REQUIRED	55	NO DTC IS DETECTED. FURTHER TESTING MAY BE REQUIRED	—	—
C1A0A	41	CONFIG UNFINISHED	A, B, C, D, E, F, G, H, I	DAS-153
C1A00	0	CONTROL UNIT	A, B, C, D, E, F, G, H, I	DAS-133
C1A01	1	POWER SUPPLY CIR	A, B, C, D, E, F, G, H, I	DAS-134
C1A02	2	POWER SUPPLY CIR 2	A, B, C, D, E, F, G, H, I	DAS-134
C1A03	3	VHCL SPEED SE CIRC	A, B, C, D, E, F, G, H, I	DAS-136
C1A04	4	ABS/TCS/VDC CIRC	A, B, C, D, E, F, G, H, I	DAS-138
C1A05	5	BRAKE SW/STOP L SW	A, B, C, D, F, G, H	DAS-140
C1A06	6	OPERATION SW CIRC	A, B, C, D, E, F, H, I	DAS-149
C1A13	13	STOP LAMP RLY FIX	A, B, C, D, E, G	DAS-154
C1A14	14	ECM CIRCUIT	A, B, C, D, E, I	DAS-166
C1A15	15	GEAR POSITION	A, B, C, D, E, I	DAS-168
C1A24	24	NP RANGE	A, B, C, D, E, F, H, G	DAS-171
C1A26	26	ECD MODE MALF	A, B, C, D, E, G	DAS-173
C1A27	27	ECD PWR SUPPLY CIR	A, B, C, D, E, G	DAS-175
C1A33	33	CAN TRANSMISSION ERR	A, B, C, D, E, I	DAS-177
C1A34	34	COMMAND ERROR	A, B, C, D, E, I	DAS-179
C1A35	35	APA CIR	A, C, D, E	DAS-181
C1A36	36	APA CAN COMM CIR	A, C, D, E	DAS-183
C1A37	133	APA CAN CIR 2	A, C, D, E	DAS-185
C1A38	132	APA CAN CIR 1	A, C, D, E	DAS-187
C1A39	39	STRG SEN CIR	A, B, C, D, E, F, G	DAS-189
C1B00	81	CAMERA UNIT MALF	F, H	DAS-191
C1B01	82	CAM AIMING INCOMP	F, H	DAS-192
C1B03	83	CAN ABNRML TMP DETCT	F, H	DAS-193
C1B5D	198	FEB OPE COUNT LIMIT	C, D, E	DAS-199
C1B53	84	SIDE RDR R MALF	F, G	DAS-194
C1B54	85	SIDE RDR L MALF	F, G	DAS-195
C1B56	86	SONAR CIRCUIT	G	DAS-196
C1B59	184	CCM CIRCUIT	A, B, C, F, G, H	DAS-197
C1B82	12	DIST SEN OFF-CENTER	A, C, D, E	DAS-200

A

B

C

D

E

F

G

H

I

J

K

L

M

N

CCS

P

ADAS CONTROL UNIT

< ECU DIAGNOSIS INFORMATION >

[ICC]

Systems for fail-safe

- A: Vehicle-to-vehicle distance control mode
- B: Conventional (fixed speed) cruise control mode
- C: Distance Control Assist (DCA)
- D: Forward Emergency Braking (FEB)
- E: Predictive Forward Collision Warning (PFCW)
- F: Blind Spot Warning (BSW)/Blind Spot Intervention (Without Active Lane control)
- G: Back-up Collision Intervention (BCI)
- H: Lane Departure Warning (LDW)/Lane Departure Prevention (LDP)
- I: Automatic Speed Control Device (ASCD) (Without ICC)

DTC		CONSULT display	Fail-safe	Reference
CONSULT	On board display		System	
C1B84	17	DIST SEN MALFUNCTION	A, C, D, E	DAS-201
C1B85	21	DIST SEN ABNORMAL TEMP	A, C, D, E	DAS-202
C1F01	91	APA MOTOR MALF	A, C, D, E, G	DAS-203
C1F02	92	APA C/U MALF	A, C, D, E, G	DAS-204
C1F05	95	APA PWR SUPPLY CIR	A, C, D, E, G	DAS-205
U0121	127	VDC CAN CIR 2	A, B, C, D, E, F, G, H, I	DAS-207
U0126	130	STRG SEN CAN CIR 1	A, B, C, D, E, F, G	DAS-209
U0235	144	ICC SENSOR CAN CIRC 1	A, C, D, E	DAS-211
U0401	120	ECM CAN CIR 1	A, B, C, D, E, F, G, I	DAS-213
U0402	122	TCM CAN CIR 1	A, B, C, D, E, F, G, H	DAS-215
U0415	126	VDC CAN CIR 1	A, B, C, D, E, F, G, H, I	DAS-217
U0424	156	HVAC CAN CIR 1	—	DAS-219
U0428	131	STRG SEN CAN CIR 2	A, B, C, D, E, F, G	DAS-220
U1000 ^{NOTE}	100	CAN COMM CIRCUIT	A, B, C, D, E, F, G, H, I	DAS-222
U1010	110	CONTROL UNIT (CAN)	A, B, C, D, E, F, G, H, I	DAS-224
U150B	157	ECM CAN CIRC 3	A, B, C, D, E, F, G, H, I	DAS-225
U150C	158	VDC CAN CIRC 3	A, B, C, D, E, F, G, H, I	DAS-227
U150D	159	TCM CAN CIRC 3	A, B, C, D, E, F, G, H	DAS-229
U150E	160	BCM CAN CIRC 3	A, B, C, D, F, G, H	DAS-231
U150F	161	AV CAN CIRC 3	—	DAS-233
U1500	145	CAM CAN CIR2	F, H	DAS-234
U1501	146	CAM CAN CIR 1	F, H	DAS-236
U1502	147	ICC SEN CAN COMM CIR	A, C, D, E	DAS-238
U1503	150	SIDE RDR L CAN CIR 2	F, G	DAS-240
U1504	151	SIDE RDR L CAN CIR 1	F, G	DAS-242
U1505	152	SIDE RDR R CAN CIR 2	F, G	DAS-244
U1506	153	SIDE RDR R CAN CIR 1	F, G	DAS-246
U1507	154	LOST COMM (SIDE RDR R)	F, G	DAS-248
U1508	155	LOST COMM (SIDE RDR L)	F, G	DAS-250
U1512	162	HVAC CAN CIRC3	F, H	DAS-252
U1513	163	METER CAN CIRC 3	A, B, C, D, E, F, G, H, I	DAS-253
U1514	164	STRG SEN CAN CIRC 3	A, B, C, D, E, F, G	DAS-255
U1515	165	ICC SENSOR CAN CIRC 3	A, C, D, E	DAS-257
U1516	166	CAM CAN CIRC 3	F, H	DAS-259
U1517	167	APA CAN CIRC 3	A, C, D, E	DAS-261

ADAS CONTROL UNIT

< ECU DIAGNOSIS INFORMATION >

[ICC]

Systems for fail-safe

- A: Vehicle-to-vehicle distance control mode
- B: Conventional (fixed speed) cruise control mode
- C: Distance Control Assist (DCA)
- D: Forward Emergency Braking (FEB)
- E: Predictive Forward Collision Warning (PFCW)
- F: Blind Spot Warning (BSW)/Blind Spot Intervention (Without Active Lane control)
- G: Back-up Collision Intervention (BCI)
- H: Lane Departure Warning (LDW)/Lane Departure Prevention (LDP)
- I: Automatic Speed Control Device (ASCD) (Without ICC)

DTC		CONSULT display	Fail-safe	Reference
CONSULT	On board display		System	
U1518	168	SIDE RDR L CAN CIRC 3	F, G	DAS-263
U1519	169	SIDE RDR R CAN CIRC 3	F, G	DAS-265
U1521	177	SONAR CAN COMMUNICATION 2	G	DAS-267
U1522	178	SONAR CAN COMMUNICATION 1	G	DAS-269
U1523	179	SONAR CAN COMMUNICATION 3	G	DAS-271
U1524	180	AVM CAN COMMUNICATION 1	G	DAS-273
U1525	181	AVM CAN COMMUNICATION 3	G	DAS-274
U1527	185	CCM CAN CIR1	A, B, C, F, G, H	DAS-276
U153F	186	CCM CAN CIR2	A, B, C, F, G, H	DAS-277
U1530	183	DR ASSIST BUZZER CAN CIR1	—	DAS-279
U1540	200	DAST 3 CAN CIR 1	C, D, E	DAS-280
U1541	201	DAST 3 CAN CIR 2	C, D, E	DAS-281

NOTE:

With the detection of “U1000” some systems do not perform the fail-safe operation.
 A system controlling based on a signal received from the control unit performs fail-safe operation when the communication with the ADAS control unit becomes inoperable.

A
B
C
D
E
F
G
H
I
J
K
L
M
N
P



ADAS CONTROL UNIT 2

< ECU DIAGNOSIS INFORMATION >

[ICC]

ADAS CONTROL UNIT 2

Reference Value

INFOID:000000013965362

VALUES ON THE DIAGNOSIS TOOL

NOTE:

The following table includes information (items) inapplicable to this vehicle. For information (items) applicable to this vehicle, refer to CONSULT display items.

Monitor item	Condition		Value/Status
MAIN SW	Ignition switch ON	When MAIN switch is pressed	On
		When MAIN switch is not pressed	Off
SET/COAST SW	Ignition switch ON	When SET/COAST switch is pressed	On
		When SET/COAST switch is not pressed	Off
CANCEL SW	Ignition switch ON	When CANCEL switch is pressed	On
		When CANCEL switch is not pressed	Off
RESUME/ACC SW	Ignition switch ON	When RESUME/ACCELERATE switch is pressed	On
		When RESUME/ACCELERATE switch is not pressed	Off
DISTANCE SW	Ignition switch ON	When DISTANCE switch is pressed	On
		When DISTANCE switch is not pressed	Off
CRUISE OPE	Drive the vehicle and activate the vehicle-to-vehicle distance control mode	When ICC system is controlling	On
		When ICC system is not controlling	Off
BRAKE SW	Ignition switch ON	When brake pedal is depressed	Off
		When brake pedal is not depressed	On
STOP LAMP SW	Ignition switch ON	When brake pedal is depressed	On
		When brake pedal is not depressed	Off
IDLE SW	Engine running	Idling	On
		Except idling (depress accelerator pedal)	Off
SET DISTANCE	<ul style="list-style-type: none"> • Start the engine and turn the ICC system ON • Press the DISTANCE switch to change the vehicle-to-vehicle distance setting 	When set to "long"	Long
		When set to "middle"	Mid
		When set to "short"	Short
CRUISE LAMP	Start the engine and press MAIN switch	ICC system ON (MAIN switch indicator ON)	On
		ICC system OFF (MAIN switch indicator OFF)	Off
OWN VHCL	NOTE: The item is indicated, but not monitored		Off
VHCL AHEAD	Drive the vehicle and activate the vehicle-to-vehicle distance control mode	When a vehicle ahead is detected (vehicle ahead detection indicator ON)	On
		When a vehicle ahead is not detected (vehicle ahead detection indicator OFF)	Off
ICC WARNING	Start the engine and press MAIN switch	When ICC system is malfunctioning (ICC system malfunction ON)	On
		When ICC system is normal (ICC system malfunction OFF)	Off

ADAS CONTROL UNIT 2

< ECU DIAGNOSIS INFORMATION >

[ICC]

Monitor item	Condition	Value/Status		
BA WARNING	Engine running	FEB OFF indicator lamp ON • When FEB system is malfunctioning • When FEB system is turned to OFF	On	A
		FEB OFF indicator lamp OFF • When FEB system is normal • When FEB system is turned to ON	Off	B
VHCL SPEED SE	While driving		Displays the vehicle speed calculated by ADAS control unit	C
SET VHCL SPD	While driving	When vehicle speed is set	Displays the set vehicle speed	D
BUZZER O/P	Engine running	When the buzzer of the following system operates • Vehicle-to-vehicle distance control mode • DCA system • PFCW system • FEB system	On	E
		When the buzzer of the following system not operates • Vehicle-to-vehicle distance control mode • DCA system • PFCW system • FEB system	Off	F
THRTL SENSOR	NOTE: The item is indicated, but not monitored		0.0	G
ENGINE RPM	Engine running		Equivalent to tachometer reading	H
WIPER SW	Ignition switch ON	Wiper not operating	Off	I
		Wiper LO operation	Low	J
		Wiper HI operation	High	K
YAW RATE	NOTE: The item is indicated, but not monitored		0.0	L
RELEASE SW NO	NOTE: The item is indicated, but not monitored		—	M
RELEASE SW NC	NOTE: The item is indicated, but not monitored		—	N
STP LMP DRIVE	Drive the vehicle and activate the vehicle-to-vehicle distance control mode	When ICC brake hold relay is activated	On	O
		When ICC brake hold relay is not activated	Off	P
D POSITION SW	Engine running	When the selector lever is in "D" position or manual mode	On	Q
		When the selector lever is in any position other than "D" or manual mode	Off	R
NP RANGE SW	Engine running	When the selector lever is in "N", "P" position	On	S
		When the selector lever is in any position other than "N", "P"	Off	T
PKB SW	Ignition switch ON	When the parking brake is applied	On	U
		When the parking brake is released	Off	V
PWR SUP MONI	Engine running		Power supply voltage value of ADAS control unit	W
VHCL SPD AT	While driving		Value of A/T vehicle speed sensor signal	X

CCS

ADAS CONTROL UNIT 2

< ECU DIAGNOSIS INFORMATION >

[ICC]

Monitor item	Condition		Value/Status
THRTL OPENING	Engine running	Depress accelerator pedal	Displays the throttle position
GEAR	While driving		Displays the gear position
CLUTCH SW SIG	Ignition switch ON	NOTE: The item is indicated, but not monitored.	Off
NP SW SIG	Ignition switch ON	When the shift lever is in neutral position	On
		When the shift lever is in any position other than neutral	Off
MODE SIG	Start the engine and press MAIN switch	When ICC system is deactivated	Off
		When vehicle-to-vehicle distance control mode is activated	ICC
		When conventional (fixed speed) cruise control mode is activated	ASCD
SET DISP IND	<ul style="list-style-type: none"> • Drive the vehicle and activate the conventional (fixed speed) cruise control mode • Press SET/COAST switch 	SET switch indicator ON	On
		SET switch indicator OFF	Off
DISTANCE	Drive the vehicle and activate the vehicle-to-vehicle distance control mode	When a vehicle ahead is detected	Displays the distance from the preceding vehicle
		When a vehicle ahead is not detected	0.0
RELATIVE SPD	Drive the vehicle and activate the vehicle-to-vehicle distance control mode	When a vehicle ahead is detected	Displays the relative speed.
		When a vehicle ahead is not detected	0.0
FCW SYSTEM ON	Ignition switch ON	When the PFCW system is ON	On
		When the PFCW system is OFF	Off
LDW SYSTEM ON	Ignition switch ON	When the LDW system is ON	On
		When the LDW system is OFF	Off
LDW ON LAMP	Ignition switch ON	When the LDW system is ON	On
		When the LDW system is OFF	Off
LANE DPRT W/L	Drive the vehicle and activate the LDW system or LDP system	Lane departure warning lamp ON	On
		Lane departure warning lamp OFF	Off
BUZZEROUTPUT	Drive the vehicle and activate the Blind Spot Warning/Blind Spot Intervention system	When the buzzer of the following system operates • Blind Spot Warning/Blind Spot Intervention system	On
		When the buzzer of the following system does not operate • Blind Spot Warning/Blind Spot Intervention system	Off
LDP) CAMERA LOST	Drive the vehicle and activate the LDW system, LDP system or Blind Spot Intervention system	Both side lane markers are detected	Detect
		Deviate side lane marker is lost	Deviate
		Both side lane markers are lost	Both
LDP) LANE UNCLEAR	While driving	Lane marker is unclear	On
		Lane marker is clear	Off
LDP) SHIFT POSITION	<ul style="list-style-type: none"> • Engine running • While driving 		Displays the shift position
LDP) TURN SIGNAL	Turn signal lamps OFF		Off
	Turn signal lamp LH blinking		LH
	Turn signal lamp RH blinking		RH
	Turn signal lamp LH and RH blinking		LH&RH

ADAS CONTROL UNIT 2

< ECU DIAGNOSIS INFORMATION >

[ICC]

Monitor item	Condition		Value/Status	
SIDE G	While driving	Vehicle turning right	Negative value	A
		Vehicle turning left	Positive value	
FUNC ITEM (FCW)	Engine running	"Forward Emergency Braking" set with the integral switch is ON	On	B
		"Forward Emergency Braking" set with the integral switch is OFF	Off	C
FUNC ITEM (LDW)	Engine running	"Lane Departure Warning" set with the integral switch is ON	On	D
		"Lane Departure Warning" set with the integral switch is OFF	Off	
FUNC ITEM (BSW)	Engine running	"Blind Spot Warning" set with the integral switch is ON	On	E
		"Blind Spot Warning" set with the integral switch is OFF	Off	
FCW SELECT	Ignition switch ON	"Forward Emergency Braking" set with the integral switch is ON	On	F
		"Forward Emergency Braking" set with the integral switch is OFF	Off	
LDW SELECT	Ignition switch ON	"Lane Departure Warning" set with the integral switch is ON	On	G
		"Lane Departure Warning" set with the integral switch is OFF	Off	
BSW SELECT	Ignition switch ON	"Blind Spot Warning" set with the integral switch is ON	On	H
		"Blind Spot Warning" set with the integral switch is OFF	Off	
WARN SYS SW	NOTE: The item is indicated, but not monitored		Off	I
BSW/BSI WARN LMP	Ignition switch ON	When the BSW system is malfunctioning	On	J
		When the BSW system is normal	Off	
BSI ON IND	Ignition switch ON	Blind Spot Intervention warning ON	On	K
		Blind Spot Intervention warning OFF	Off	
BSI/BSW	Ignition switch ON	Blind Spot Intervention system ON	On	L
		Blind Spot Intervention system OFF	Off	
BSW SYSTEM ON	Ignition switch ON	When the BSW system is ON	On	M
		When the BSW system is OFF	Off	
BSW/CTA SW	NOTE: The item is indicated, but not monitored		—	N
BSW/CTA SW IND	NOTE: The item is indicated, but not monitored		—	
BCI ON IND	NOTE: The item is indicated, but not monitored		—	
BCI OFF IND	NOTE: The item is indicated, but not monitored		—	
BCI WARNING IND	NOTE: The item is indicated, but not monitored		—	
BCI HI TEMP WARN IND	NOTE: The item is indicated, but not monitored		—	
BATTERY CIRCUIT OFF	NOTE: The item is indicated, but not used		Off	P
LDW ON INDICATOR	Ignition switch ON	LDW system display ON	On	
		LDW system display OFF	Off	

ADAS CONTROL UNIT 2

< ECU DIAGNOSIS INFORMATION >

[ICC]

Monitor item	Condition		Value/Status
LDW WARNING INDICATOR	Ignition switch ON	When the LDW system is malfunctioning	On
		When the LDW system is normal	Off
SYSTEM CANCEL MESSAGE	Ignition switch ON	When the vehicle is normal	NOREQ
		When the wheel is slipping	SLIP
		When the drive mode selector is SNOW mode	SNOW
		When the VDC is OFF	VDC OFF
CAMERA HI TEMP MSG	Ignition switch ON	Lane camera unit high temperature warning display ON	On
		Lane camera unit high temperature warning display OFF	Off
ITS SETTING ITEM(DCA)	Ignition switch ON		On
ITS SETTING ITEM(LDP)	Ignition switch ON		On
ITS SETTING ITEM(BSI)	Ignition switch ON		On
BSI WARNING INDICATOR	Engine running	When the Blind Spot Intervention is malfunctioning	On
		When the Blind Spot Intervention is normal	Off
BSW ON INDICATOR	Ignition switch ON	BSW system display ON	On
		BSW system display OFF	Off
SIDE RADAR BLOCK COND	Ignition switch ON	Front bumper or side radar is dirty	On
		Front bumper and side radar is clean	Off
LDW WARNING ALERT TIMING	Ignition switch ON	LDW system OFF	Nothing
		Lane departure warning timing is early setting	Early
		Lane departure warning timing is late setting	Late
BSW IND BRIGHTNESS	Ignition switch ON	BSW system OFF	Nothing
		Blind Spot Warning/Blind Spot Intervention indicator brightness bright	Bright
		Blind Spot Warning/Blind Spot Intervention indicator brightness normal	Normal
		Blind Spot Warning/Blind Spot Intervention indicator brightness dark	Dark
PMAS SW	NOTE: The item is indicated, but not monitored		—
PMAS IND	NOTE: The item is indicated, but not monitored		—
G SENSOR SIGNAL	NOTE: The item is indicated, but not monitored		—
PMAS BUZZER REQ 1	NOTE: The item is indicated, but not monitored		—
PMAS BUZZER REQ 2	NOTE: The item is indicated, but not monitored		—
PMAS BUZZER REQ 3	NOTE: The item is indicated, but not monitored		—
EAP SW	NOTE: The item is indicated, but not monitored		—
EAP SW IND	NOTE: The item is indicated, but not monitored		—
RADAR COMMAND SIGNAL	NOTE: The item is indicated, but not monitored		—

ADAS CONTROL UNIT 2

< ECU DIAGNOSIS INFORMATION >

[ICC]

Monitor item	Condition	Value/Status
ICC SYSTEM ON	NOTE: The item is indicated, but not monitored	—
ICC AVAILABLE COND	NOTE: The item is indicated, but not monitored	—
FEB AVAILABLE COND	NOTE: The item is indicated, but not monitored	—
FCW AVAILABLE COND	NOTE: The item is indicated, but not monitored	—
EBA AVAILABLE COND	NOTE: The item is indicated, but not monitored	—

TERMINAL LAYOUT

PHYSICAL VALUES

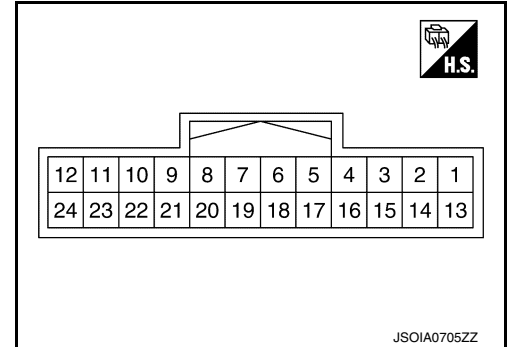

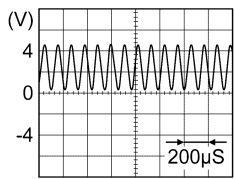
Terminal No. (Wire color)		Description		Condition	Standard value	Reference value
+	-	Signal name	Input/ Output			
1 (R)	2 (B)	Warning buzzer signal	Output	Ignition switch OFF	0 - 0.1 V	Approx. 0 V
				Ignition switch ON	At "ADAS buzzer 2" test of "Active test"	
2 (B)	Ground	Ground	—	Ignition switch ON	0 - 0.1 V	Approx. 0 V
3 (R)	—	Chassis communication-L	—	—	—	—
9 (L)		ITS communication-H	—	—	—	—
12 (R)	24 (L)	Steering vibration motor signal	Output	Ignition switch OFF	0 V	Approx. 0 V
				Ignition switch ON	At "Vibration motor" test of "Active test"	12 V
13 (G)	2 (B)	Warning buzzer signal ground	—	Ignition switch ON	0 - 0.1 V	Approx. 0 V
15 (L)	—	Chassis communication-H	—	—	—	—
16 (G)	2 (B)	Ignition power supply	Input	Ignition switch ON	10 - 16 V	Battery voltage

CCS

ADAS CONTROL UNIT 2

< ECU DIAGNOSIS INFORMATION >

[ICC]

Terminal No. (Wire color)		Description		Condition	Standard value	Reference value
+	-	Signal name	Input/ Output			
21 (P)	—	ITS communication-L	—	—	—	—
24 (L)	2 (B)	Steering vibration motor signal ground	Output	Ignition switch OFF	4 V	Approx. 4 V
				Ignition switch ON	At "Vibration motor" test of "Active test"	0 V

Fail-safe (ADAS Control Unit 2)

INFOID:0000000113965363

If a malfunction occurs in each system, ADAS control unit 2 cancels each control, sounds a beep, and turns ON the warning or indicator lamp.

System	Buzzer	Warning lamp/Warning display	Description
Lane Departure Warning (LDW)	—	Warning systems indicator (Lane position: Yellow)	Cancel
Lane Departure Prevention (LDP)	Low-pitched tone	Warning systems indicator (Lane position: Yellow)	Cancel
Blind Spot Intervention	Low-pitched tone	Warning systems indicator (Blind spot position: Yellow)	Cancel

DTC Inspection Priority Chart

INFOID:0000000113965364

If multiple DTCs are detected simultaneously, check them one by one depending on the following DTC inspection priority chart.

Priority	Detected items (DTC)	
1	<ul style="list-style-type: none"> • U0121-83: VDC CAN CIR 2 • U0428-83: STRG SEN CAN CIR 2 • U1500-83: CAM CAN CIR 2 • U1501-82: CAM CAN CIR 1 	
2	<ul style="list-style-type: none"> • C1A00-44: CONTROL UNIT • C1A00-45: CONTROL UNIT • C1A00-46: CONTROL UNIT • C1A00-47: CONTROL UNIT • C1A00-49: CONTROL UNIT • C1A01-16: POWER SUPPLY CIR • C1A02-17: POWER SUPPLY CIR 2 • C1A03-62: VHCL SPEED SE CIRC • C1A04-04: ABS/TCS/VDC CIRC • C1A04-29: ABS/TCS/VDC CIRC • C1A0E-49: CONTROL UNIT • C1A05-62: BRAKE SW/STOP L SW • C1A14-04: ECM CIRCUIT • C1A1B-14: CONTROL UNIT • C1A1C-14: CONTROL UNIT • C1A1D-14: CONTROL UNIT • C1A1E-14: CONTROL UNIT • C1A1F-14: CONTROL UNIT • C1A24-62: NP RANGE • C1A39-49: STRG SEN CIR • C1A41-49: CONTROL UNIT 	<ul style="list-style-type: none"> • C1B00-49: CAMERA UNIT MALF • C1B01-54: CAM AIMING INCOMP • C1B03-4B: CAM ABNRML TMP DETCT • C1B53-04: SIDE RDR R MALF • C1B54-04: SIDE RDR L MALF • C1B59-97: CCM CIRCUIT • U0126-82: STRG SEN CAN CIR 1 • U0401-82: ECM CAN CIR 1 • U0402-82: TCM CAN CIR 1 • U0415-82: VDC CAN CIR 1 • U1000-01: CAN COMM CIRCUIT • U1010-49: CONTROL UNIT (CAN) • U1321-55: CONFIG UNFINISHED • U1503-83: SIDE RDR L CAN CIR 2 • U1504-82: SIDE RDR L CAN CIR 1 • U1505-83: SIDE RDR R CAN CIR 2 • U1506-82: SIDE RDR R CAN CIR 1 • U1507-87: LOST COMM (SIDE RDR R) • U1508-87: LOST COMM (SIDE RDR L)

ADAS CONTROL UNIT 2

< ECU DIAGNOSIS INFORMATION >

[ICC]

DTC Index

INFOID:000000013965365

Systems for fail-safe

- A: Blind Spot Intervention (Without Active Lane control)
- B: Lane Departure Warning (LDW)/Lane Departure Prevention (LDP) (Without Active Lane control)

DTC	Items (CONSULT screen terms)	Sub type (CONSULT screen terms)	Fail-safe	Reference	
			System		
C1A00	44	CONTROL UNIT	[DATA MEMORY ERROR]	A,B	DAS-133
	45		[PROGRAM MEMORY ERROR]	A,B	
	46		[CALIB/PRMTER MEMORY ERROR]	A,B	
	47		[WATCHDOG/SAFETY μ C ERROR]	A,B	
	49		[INTERNAL ELECTRONIC ERROR]	A,B	
C1A01	16	POWER SUPPLY CIR	[CIRC VOLT BELOW THRESHOLD]	A,B	DAS-134
C1A02	17	POWER SUPPLY CIR 2	[CIRC VOLT ABOVE THRESHOLD]	A,B	DAS-134
C1A03	62	VHCL SPEED SE CIRC	[SIGNAL COMPARE ERROR]	A,B	DAS-136
C1A04	04	ABS/TCS/VDC CIRC	[SYSTEM INTERNAL MALFUNCTN]	A,B	DAS-138
	29		[SIGNAL INVALID]	A,B	
C1A05	62	BRAKE SW/STOP L SW	[SIGNAL COMPARE ERROR]	A,B	DAS-140
C1A0E	49	CONTROL UNIT	[INTERNAL ELECTRONIC ERROR]	A,B	DAS-299
C1A14	04	ECM CIRCUIT	[SYSTEM INTERNAL MALFUNCTN]	A,B	DAS-166
C1A1B	14	CONTROL UNIT	[CIRC SHORT TO GRND OR OPEN]	A,B	DAS-302
C1A1C	14	CONTROL UNIT	[CIRC SHORT TO GRND OR OPEN]	A,B	DAS-303
C1A1D	14	CONTROL UNIT	[CIRC SHORT TO GRND OR OPEN]	A,B	DAS-304
C1A1E	14	CONTROL UNIT	[CIRC SHORT TO GRND OR OPEN]	A,B	DAS-305
C1A1F	14	CONTROL UNIT	[CIRC SHORT TO GRND OR OPEN]	A,B	DAS-306
C1A24	62	NP RANGE	[SIGNAL COMPARE ERROR]	A,B	DAS-171
C1A39	49	STRG SEN CIR	[INTERNAL ELECTRONIC ERROR]	A	DAS-189
C1A41	49	CONTROL UNIT	[INTERNAL ELECTRONIC ERROR]	A,B	DAS-311
C1B00	49	CAMERA UNIT MALF	[INTERNAL ELECTRONIC ERROR]	A,B	DAS-191
C1B01	54	CAM AIMING INCOMP	[MISSING CALIBRATION]	A,B	DAS-192
C1B03	4B	CAN ABNRML TMP DETCT	[OVER TEMPERATURE]	A,B	DAS-193
C1B53	04	SIDE RDR R MALF	[SYSTEM INTERNAL MALFUNCTN]	A	DAS-194
C1B54	04	SIDE RDR L MALF	[SYSTEM INTERNAL MALFUNCTN]	A	DAS-195
C1B59	97	CCM CIRCUIT	[CMP/SYS OPR OBST OR BLKD]	A	DAS-197
U0121	83	VDC CAN CIR 2	[PROTECT CALCULATION ERROR]	A,B	DAS-207
U0126	82	STRG SEN CAN CIR 1	[SEQUENCE COUNTER INCORRECT]	A	DAS-209
U0401	82	ECM CAN CIR 1	[SEQUENCE COUNTER INCORRECT]	A,B	DAS-213
U0402	82	TCM CAN CIR 1	[SEQUENCE COUNTER INCORRECT]	A,B	DAS-215
U0415	82	VDC CAN CIR 1	[SEQUENCE COUNTER INCORRECT]	A,B	DAS-217
U0428	83	STRG SEN CAN CIR 2	[PROTECT CALCULATION ERROR]	A	DAS-220
U1000 ^N OTE	01	CAN COMM CIRCUIT	[ELECTRICAL MALFUNCTION]	A,B	DAS-222
U1010	49	CONTROL UNIT (CAN)	[INTERNAL ELECTRONIC ERROR]	A,B	DAS-224
U1321	55	CONFIG UNFINISHED	[NOT CONFIGURED]	A,B	DAS-333
U1500	83	CAM CAN CIR2	[PROTECT CALCULATION ERROR]	A,B	DAS-234
U1501	82	CAM CAN CIR 1	[SEQUENCE COUNTER INCORRECT]	A,B	DAS-236

ADAS CONTROL UNIT 2

< ECU DIAGNOSIS INFORMATION >

[ICC]

Systems for fail-safe

- A: Blind Spot Intervention (Without Active Lane control)
- B: Lane Departure Warning (LDW)/Lane Departure Prevention (LDP) (Without Active Lane control)

DTC		Items (CONSULT screen terms)	Sub type (CONSULT screen terms)	Fail-safe	Reference
				System	
U1503	83	SIDE RDR L CAN CIR 2	[PROTECT CALCULATION ERROR]	A	DAS-240
U1504	82	SIDE RDR L CAN CIR 1	[SEQUENCE COUNTER INCORRECT]	A	DAS-242
U1505	83	SIDE RDR R CAN CIR 2	[PROTECT CALCULATION ERROR]	A	DAS-244
U1506	82	SIDE RDR R CAN CIR 1	[SEQUENCE COUNTER INCORRECT]	A	DAS-246
U1507	87	LOST COMM (SIDE RDR R)	[MISSING MESSAGE]	A	DAS-248
U1508	87	LOST COMM (SIDE RDR L)	[MISSING MESSAGE]	A	DAS-250

NOTE:

With the detection of "U1000-01" some systems do not perform the fail-safe operation.

A system controlling based on a signal received from the control unit performs fail-safe operation when the communication with the ADAS control unit becomes inoperable.

ICC SENSOR

< ECU DIAGNOSIS INFORMATION >

[ICC]

ICC SENSOR

Reference Value

INFOID:0000000013711803

VALUES ON THE DIAGNOSIS TOOL

NOTE:

The following table includes information (items) inapplicable to this vehicle. For information (items) applicable to this vehicle, refer to CONSULT display items.

Monitor item	Condition		Value/Status
VHCL SPEED SE	While driving		Value of vehicle speed signal (wheel speed)
YAW RATE	While driving	Vehicle stopped	0.0
		Vehicle turning right	Positive value
		Vehicle turning left	Negative value
PWR SUP MONI	Ignition switch ON		Power supply voltage value of ICC sensor
DISTANCE	Drive the vehicle and activate the vehicle-to-vehicle distance control mode	When a vehicle ahead is detected	Displays the distance from the preceding vehicle
		When a vehicle ahead is not detected	0.0
RELATIVE SPD	Drive the vehicle and activate the vehicle-to-vehicle distance control mode	When a vehicle ahead is detected	Displays the relative speed
		When a vehicle ahead is not detected	0.0
RADAR OFFSET	NOTE: The item is indicated, but not used		—
RADAR HEIGHT	NOTE: The item is indicated, but not used		—
STEERING ANGLE	Ignition switch ON	When setting the steering wheel in straight-ahead position	0.0
		When turning the steering wheel 90° rightward	+90
		When turning the steering wheel 90° leftward	-90
STRG ANGLE SPEED	Ignition switch ON	At the time of turning the steering wheel	Steering wheel turning speed is displayed
L/R ADJUST	Ignition switch ON	At the completion of radar alignment adjustment	Horizontal correction value is displayed
U/D ADJUST	Ignition switch ON	At the completion of radar alignment adjustment	Vertical correction value is displayed

TERMINAL LAYOUT

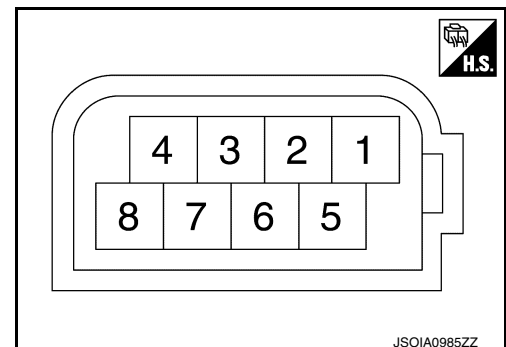

A
B
C
D
E
F
G
H
I
J
K
L
M
N

CCS

P

ICC SENSOR

< ECU DIAGNOSIS INFORMATION >

[ICC]

PHYSICAL VALUES

Terminal No. (Wire color)		Description		Condition	Standard value	Reference value
+	-	Signal name	Input/ Output			
1 (R)	8 (B)	Ignition power supply	Input	Ignition switch ON	10 - 16 V	Battery voltage
3 (L)		ITS communication-H	—	—	—	—
6 (Y)		ITS communication-L	—	—	—	—
8 (B)	Ground	Ground	—	Ignition switch ON	0 - 0.1 V	Approx. 0 V

Fail-safe (ICC Sensor)

INFOID:000000013711804

If a malfunction occurs in the ICC sensor, ADAS control unit cancels control, sounds a beep, and turns ON the ICC system warning in the information display.

DTC Inspection Priority Chart

INFOID:000000013711805

If multiple DTCs are detected simultaneously, check them one by one depending on the following DTC inspection priority chart.

Priority	Detected items (DTC)
1	<ul style="list-style-type: none"> • U1000: CAN COMM CIRCUIT • U1010: CONTROL UNIT (CAN)
2	<ul style="list-style-type: none"> • C1A50: ADAS MALFUNCTION
3	<ul style="list-style-type: none"> • C1A01: POWER SUPPLY CIR • C1A02: POWER SUPPLY CIR 2 • C1A12: RADAR OFF-CENTER • C1A16: RADAR BLOCKED • C1A21: UNIT HIGH TEMP • C1A23: UNIT LOW TEMP • C1A39: STRG SEN CIR • U0104: ADAS CAN CIR1 • U0121: VDC CAN CIR2 • U0126: STRG SEN CAN CIR1 • U0405: ADAS CAN CIR2 • U0415: VDC CAN CIR1 • U0428: STRG SEN CAN CIR2
4	<ul style="list-style-type: none"> • C1A00: CONTROL UNIT

DTC Index

INFOID:000000013711806

×: Applicable

ICC SENSOR

< ECU DIAGNOSIS INFORMATION >

[ICC]

DTC	CONSULT display	Fail-safe				Reference
		Vehicle-to-vehicle distance control mode	Conventional (fixed speed) cruise control mode	Distance Control Assist (DCA)	Forward Emergency Braking (FEB) / Predictive Forward Collision Warning (PFCW)	
C1A00	CONTROL UNIT	x	x	x	x	CCS-150
C1A01	POWER SUPPLY CIR	x	x	x	x	CCS-151
C1A02	POWER SUPPLY CIR2	x	x	x	x	CCS-151
C1A12	RADAR OFF-CENTER	x		x	x	CCS-152
C1A16	RADAR BLOCKED	x		x	x	CCS-153
C1A21	UNIT HIGH TEMP	x	x	x	x	CCS-155
C1A23	UNIT LOW TEMP	x	x	x	x	CCS-156
C1A39	STRG SEN CIR	x	x	x	x	CCS-157
C1A50	ADAS MALFUNCTION	x	x	x	x	CCS-158
U0104	ADAS CAN CIR1	x	x	x	x	CCS-159
U0121	VDC CAN CIR2	x	x	x	x	CCS-161
U0126	STRG SEN CAN CIR1	x	x	x	x	CCS-163
U0405	ADAS CAN CIR2	x	x	x	x	CCS-165
U0415	VDC CAN CIR1	x	x	x	x	CCS-167
U0428	STRG SEN CAN CIR2	x	x	x	x	CCS-169
U1000	CAN COMM CIRCUIT	x	x	x	x	CCS-171
U1010	CONTROL UNIT (CAN)	x	x	x	x	CCS-172

A
B
C
D
E
F
G
H
I
J
K
L
M
N
P

CCS

ACCELERATOR PEDAL ACTUATOR

< ECU DIAGNOSIS INFORMATION >

[ICC]

ACCELERATOR PEDAL ACTUATOR

Reference Value

INFOID:000000013965368

VALUES ON THE DIAGNOSIS TOOL

NOTE:

The following table includes information (items) inapplicable to this vehicle. For information (items) applicable to this vehicle, refer to CONSULT display items.

Monitor item	Condition		Value/Status
TGT FBK FRC	Drive the vehicle and operate the DCA system	When the ADAS control unit is controlling the accelerator pedal actuator	It changes with the demand from the ADAS control unit
TGT MOT POSI	NOTE: The item is indicated, but not used.		—
ACT MOT POSI	Engine running	Depress accelerator pedal	It changes according to the depressed amount of accelerator pedal
AP OPEN	Engine running	Depress accelerator pedal	It changes according to the depressed amount of accelerator pedal
APA TEMP	Engine running		Display the accelerator pedal actuator integrated motor temperature
APA CURRENT	Drive the vehicle and operate the DCA system	When the ADAS control unit is controlling the accelerator pedal actuator	Display the accelerator pedal actuator motor operation consumption current
APA PWR	Ignition switch ON		Battery voltage
APA OPE STATS	Engine running	When the accelerator pedal actuator control is permitted	On
		When the accelerator pedal actuator control is invalid	Off
APA STATS	Engine running	When the accelerator pedal actuator is normal	Ready
		When the accelerator pedal actuator is temporarily malfunctioning	TP NG
		When the accelerator pedal actuator is malfunctioning	NG
		During the accelerator pedal actuator operation preparations	Init

TERMINAL LAYOUT

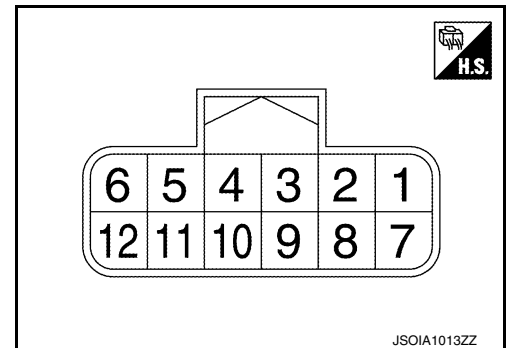

PHYSICAL VALUES

ACCELERATOR PEDAL ACTUATOR

< ECU DIAGNOSIS INFORMATION >

[ICC]

Terminal No. (Wire color)		Description		Condition	Standard value	Reference value
+	-	Signal name	Input/ Output			
1 (BR)	7 (B)	Battery power supply	Input	Ignition switch OFF	8 - 16 V	Battery voltage
2 (G)		Ignition power supply	Input	Ignition switch ON	8 - 16 V	Battery voltage
3 (L)		ITS communication-H	—	—	—	—
7 (B)	Ground	Ground	—	Ignition switch ON	0 - 0.1 V	Approx. 0 V
9 (Y)	7 (B)	ITS communication-L	—	—	—	—

Fail-safe (Accelerator Pedal Actuator)

INFOID:0000000113965369

If a malfunction occurs in the accelerator pedal actuator, ADAS control unit cancels following systems.

- Vehicle-to-vehicle distance control mode
- Distance Control Assist (DCA)
- Forward Emergency Braking (FEB)
- Back-up Collision Intervention (BCI)

DTC Inspection Priority Chart

INFOID:0000000113965370

If multiple DTCs are detected simultaneously, check them one by one depending on the following DTC inspection priority chart.

Priority	Detected items (DTC)
1	<ul style="list-style-type: none"> • U1000: CAN COMM CIRCUIT • U1010: CONTROL UNIT (CAN)
2	<ul style="list-style-type: none"> • C1F02: APA C/U MALF
3	<ul style="list-style-type: none"> • C1F01: APA MOTOR MALF • C1F03: APA HI TEMP • C1F05: APA PWR SUPPLY CIR • C1F06: CAN CIR2 • C1F07: CAN CIR1

DTC Index

INFOID:0000000113965371

NOTE:

- The details of time display are as per the following.
- CRNT: A malfunction is detected now
- PAST: A malfunction was detected in the past
- IGN counter is displayed in FFD (Freeze Frame Data).
- 0: The malfunctions that are detected now
- 1 - 39: It increases like 0 → 1 → 2 ... 38 → 39 after returning to the normal condition whenever the ignition switch OFF → ON. It returns to 0 when a malfunction is detected again in the process.
- If it is over 39, it is fixed to 39 until the self-diagnosis results are erased.

×: Applicable

CONSULT display	Fail-safe function	Reference
C1F01: APA MOTOR MALF	×	DAS-609
C1F02: APA C/U MALF	×	DAS-610
C1F03: APA HI TEMP	—	DAS-611
C1F05: APA PWR SUPPLY CIR	×	DAS-613
C1F06: CAN CIR2	×	DAS-614

A
B
C
D
E
F
G
H
I
J
K
L
M
N
P



ACCELERATOR PEDAL ACTUATOR

< ECU DIAGNOSIS INFORMATION >

[ICC]

CONSULT display	Fail-safe function	Reference
C1F07: CAN CIR1	×	DAS-616
U1000: CAN COMM CIRCUIT	×	DAS-622
U1010: CONTROL UNIT (CAN)	×	DAS-626

< WIRING DIAGRAM >

WIRING DIAGRAM

INTELLIGENT CRUISE CONTROL

Wiring Diagram

VR ENGINE

INFOID:000000013711810

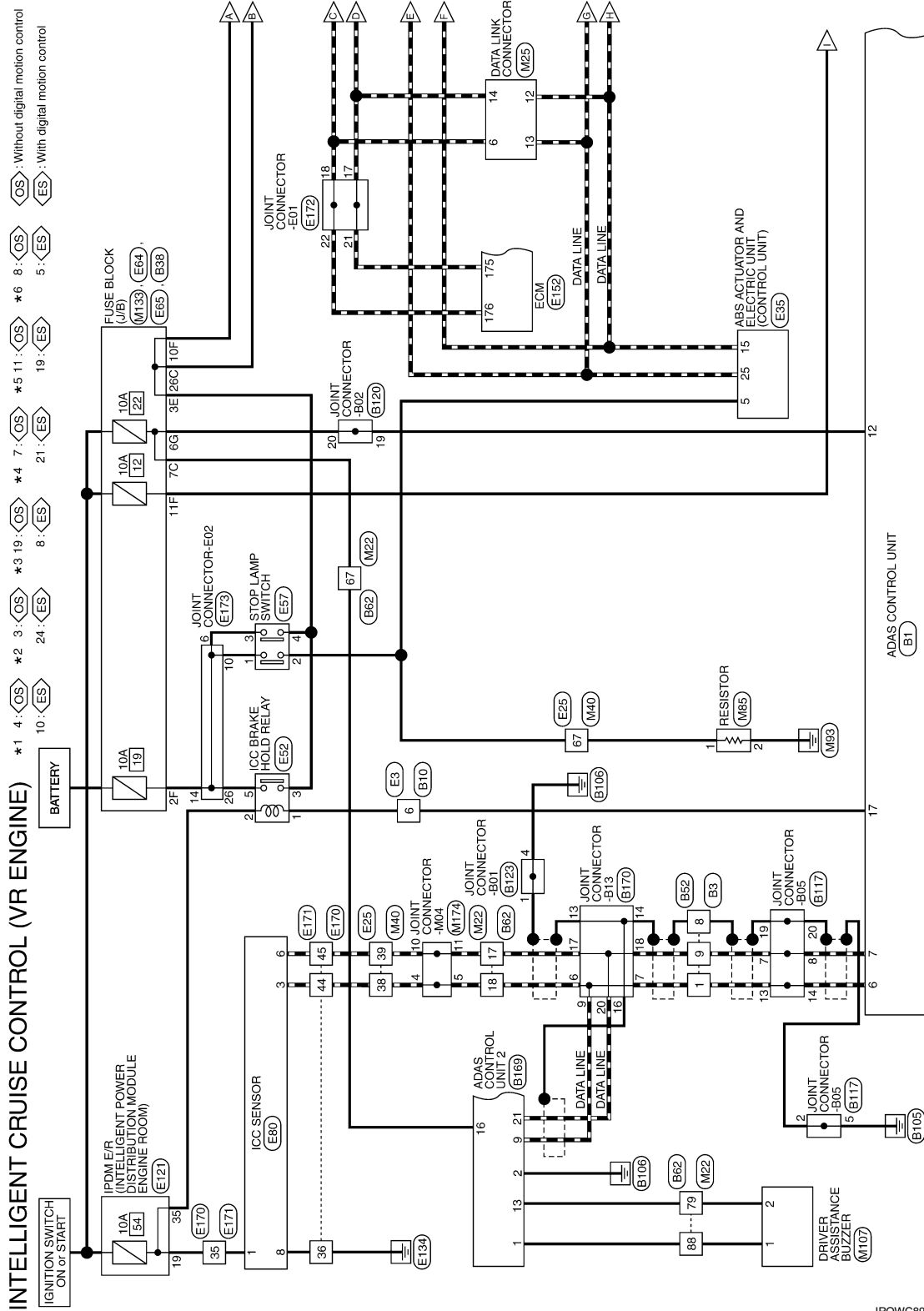

*: This connector is not shown in "Harness Layout".

2016/04/07

JROWC8950GB

A
B
C
D
E
F
G
H
I
J
K
L
M
N
P



INTELLIGENT CRUISE CONTROL

< WIRING DIAGRAM >

[ICC]

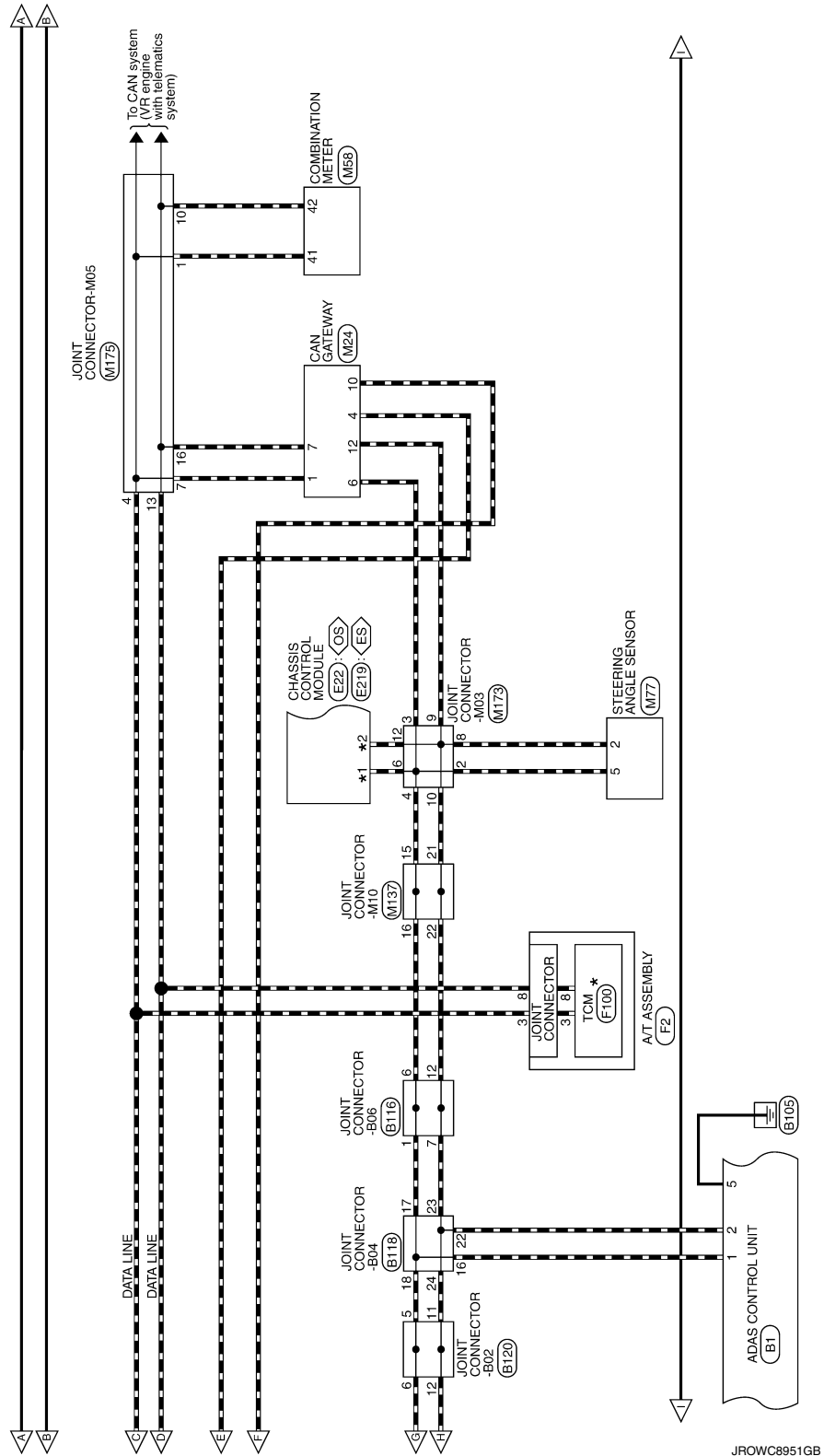

JROWC8951GB

INTELLIGENT CRUISE CONTROL

< WIRING DIAGRAM >

[ICC]

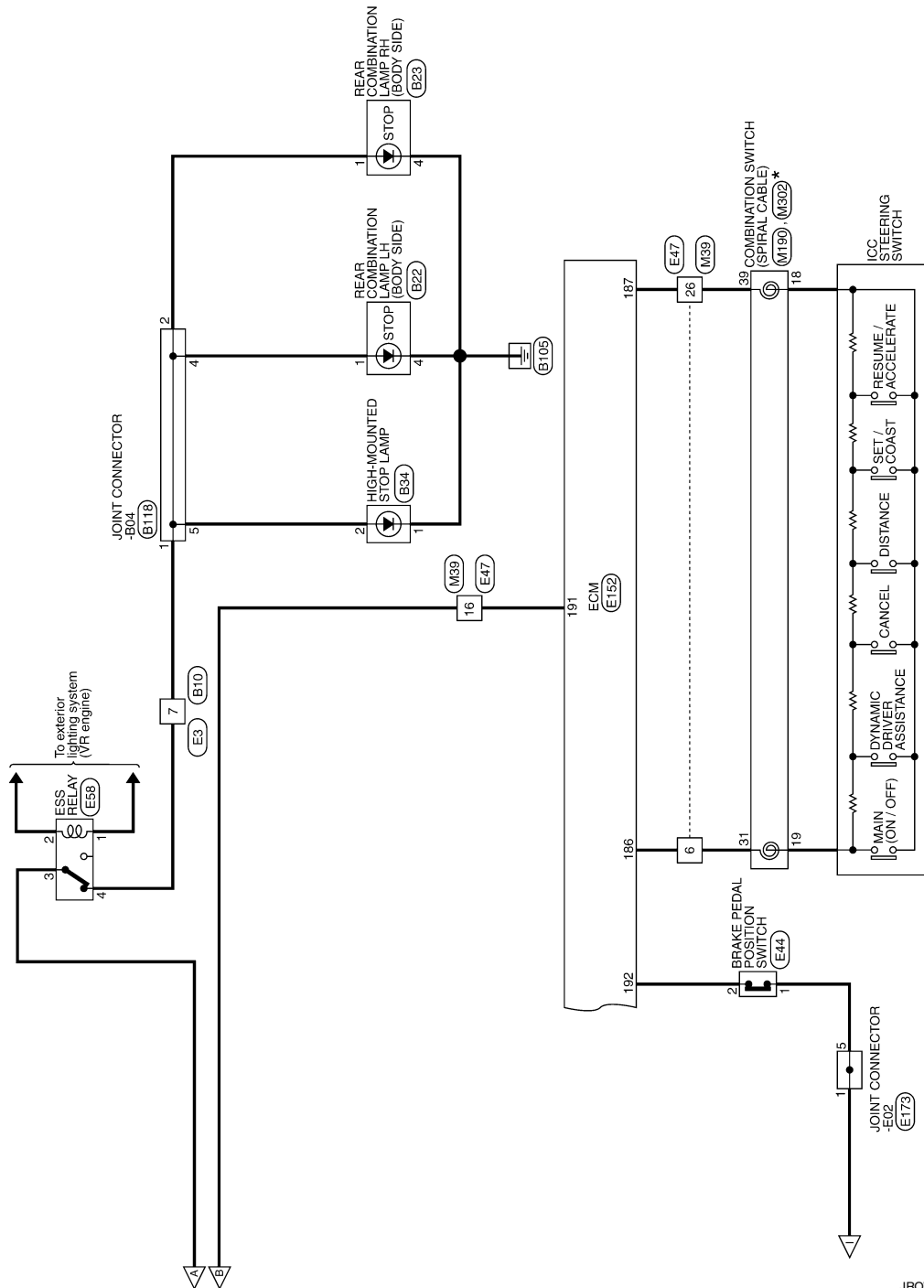

JROWC8952GB

A
B
C
D
E
F
G
H
I
J
K
L
M
N
P

CCS

INTELLIGENT CRUISE CONTROL

< WIRING DIAGRAM >

[ICC]

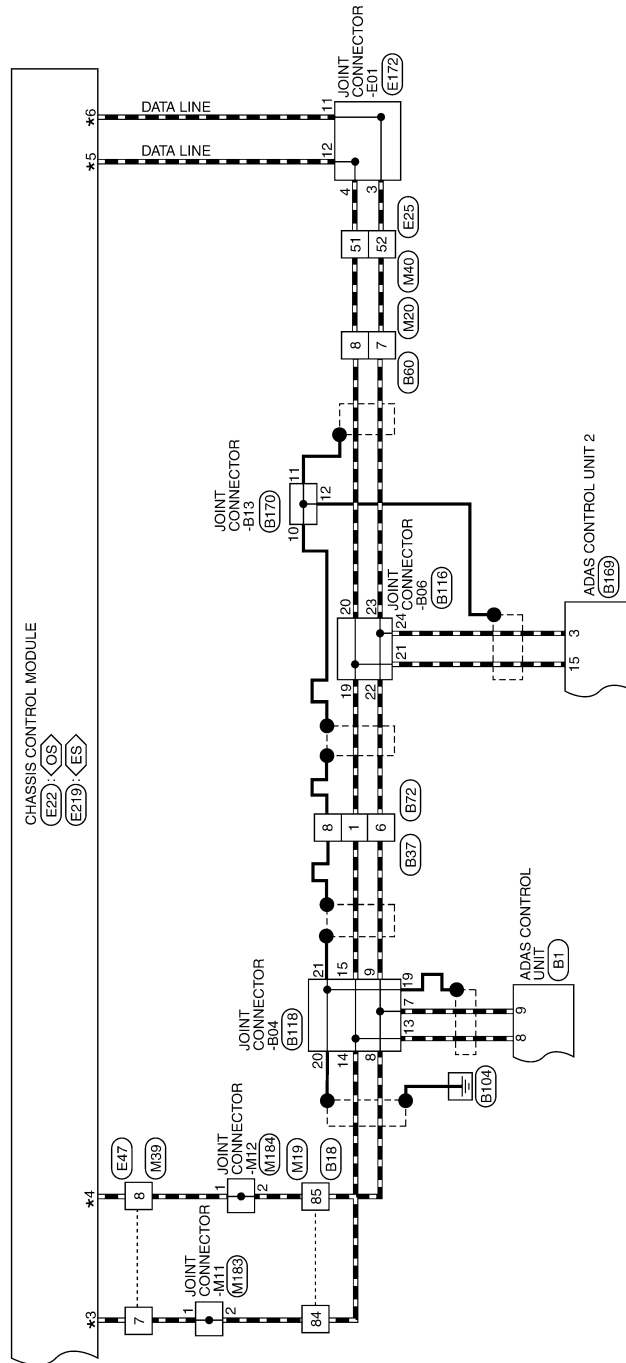

JROWC8953GB

INTELLIGENT CRUISE CONTROL

[ICC]

< WIRING DIAGRAM >

INTELLIGENT CRUISE CONTROL (VR ENGINE)

Connector No.	B1
Connector Name	ADAS CONTROL UNIT
Connector Type	TH24FW-NH



12	9	8	7	6	5	2	1
24	23						

Terminal No.	Color Of Wire	Signal Name (Specification)
1	L	CAN-H
2	R	CAN-L
5	B	GROUND
6	L	ITS COMMUNICATION-H
7	P	ITS COMMUNICATION-L
8	L	CHASSIS COMMUNICATION-H
9	R	CHASSIS COMMUNICATION-L
12	G	IGNITION POWER SUPPLY (With 2.0L turbo gasoline engine)
12	GR	IGNITION POWER SUPPLY (With VR30 engine)
17	V	BRAKE HOLD R/LY DRIVE SIGNAL
23	Y	STEERING SW SIGNAL GROUND
24	SB	STEERING SW SIGNAL

Connector No.	B3
Connector Name	WIRE TO WIRE
Connector Type	NS16FW-CS



7	6	5	4	3	2	1
18	15	14	13	12	11	10
9	8					

Terminal No.	Color Of Wire	Signal Name (Specification)
1	L	
4	B	- [With 2.0L turbo gasoline engine]
4	BR	- [With VR30 engine]
5	BR	- [With 2.0L turbo gasoline engine and with BOSE system]
5	Y	- [Except with 2.0L turbo gasoline engine and with BOSE system]
6	SHIELD	
7	R	

8	SHIELD	-
9	P	-
11	B	-
12	GR	-
13	G	-
14	B	-
15	W	-
16	BR	-

Connector No.	B10
Connector Name	WIRE TO WIRE
Connector Type	TH24FW-NH



12	11	10	9	8	7	6	5	4	3	2	1
24	23	22	21	20	19	18	17	16	15	14	13

Terminal No.	Color Of Wire	Signal Name (Specification)
1	LG	- [With 2.0L turbo gasoline engine]
1	Y	- [With VR30 engine]
2	W	
4	P	- [With VR30 engine]
4	SB	- [With 2.0L turbo gasoline engine]
5	L	
6	V	
7	LG	
8	R	
9	W	
10	B	
11	G	
12	R	
13	GR	
14	RG	
15	BR	
16	LG	
17	V	
18	BR	
19	LG	- [With 2.0L turbo gasoline engine]
19	Y	- [With VR30 engine]
20	Y	
21	R	- [With 2.0L turbo gasoline engine]
21	V	- [With VR30 engine]
22	L	

23	V	-
24	B	- [With VR30 engine]
24	R	- [With 2.0L turbo gasoline engine]

Connector No.	B18
Connector Name	WIRE TO WIRE
Connector Type	TH80FW-CS16-TMA



1	2	3	4	5	6	7	8	9	10	11	12	13	14	15	16	17	18	19	20	21	22	23	24	25	26	27	28	29	30	31	32	33	34	35
---	---	---	---	---	---	---	---	---	----	----	----	----	----	----	----	----	----	----	----	----	----	----	----	----	----	----	----	----	----	----	----	----	----	----

Terminal No.	Color Of Wire	Signal Name (Specification)
1	Y	
2	G	
3	L	
5	Y	
7	V	
10	BG	
11	BG	
12	LG	
13	GR	
14	R	
15	L	
16	V	
18	W	
19	BR	
20	W	
22	R	
23	V	
24	R	- [With 2.0L turbo gasoline engine]
24	Y	- [With VR30 engine]
25	V	- [With 2.0L turbo gasoline engine]
25	W	- [With VR30 engine]
26	G	
27	R	
28	R	
31	B	- [With VR30 engine]
31	BR	- [With 2.0L turbo gasoline engine]
32	B	
33	B	
34	LG	
35	P	

36	W	
37	SR	
38	LG	
40	P	
41	SR	
42	BR	
43	BG	
44	BG	
46	R	
50	W	
51	SR	
52	V	
53	LG	
54	R	
55	R	
58	V	
59	GR	
60	G	
61	G	
62	BG	
63	BR	
64	Y	
66	R	
70	R	
71	W	
72	B	
73	W	
74	L	
75	R	
76	BR	
77	B	
78	SR	
79	W	
81	B	
82	R	
83	BG	
84	L	
86	B	
88	B	
88	G	
89	V	
91	GR	
93	GR	
94	GR	
96	Y	
98	BR	- [With VR30 engine and with BOSE system]
98	Y	- [Except with VR30 engine and with BOSE system]

A
B
C
D
E
F
G
H
I
J
K
L
M
N
P



INTELLIGENT CRUISE CONTROL

[ICC]

< WIRING DIAGRAM >

INTELLIGENT CRUISE CONTROL (VR ENGINE)

Connector No.	B22
Connector Name	REAR COMBINATION LAMP LH (BODY SIDE)
Connector Type	NSD4MW-CS



Terminal No.	Color Of Wire	Signal Name [Specification]
1	LG	-
2	P	-
3	SB	-
4	B	-

Connector No.	B23
Connector Name	REAR COMBINATION LAMP RH (BODY SIDE)
Connector Type	NSD4MW-CS



Terminal No.	Color Of Wire	Signal Name [Specification]
1	LG	-
2	R	-
3	V	-
4	B	-

Connector No.	B34
Connector Name	HIGH-MOUNTED STOP LAMP
Connector Type	TK02MBR-P



Terminal No.	Color Of Wire	Signal Name [Specification]
1	B	-
2	LG	-

Connector No.	B37
Connector Name	WIRE TO WIRE
Connector Type	TH08MW-NH



Terminal No.	Color Of Wire	Signal Name [Specification]
1	L	-
2	SHIELD	-
3	R	-
4	L	-
5	R	-
6	R	-
7	D	-
8	SHIELD	-

Connector No.	B38
Connector Name	FUSE BLOCK (J/B)
Connector Type	NS10PW-CS



Terminal No.	Color Of Wire	Signal Name [Specification]
1G	GR	-
2G	W	-
3G	BR	-
5G	W	-
6G	GR	-

Connector No.	B52
Connector Name	WIRE TO WIRE
Connector Type	NS16MW-CS

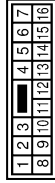

Terminal No.	Color Of Wire	Signal Name [Specification]
1	L	-
4	B	- [With 2.0L turbo gasoline engine]
4	BR	- [With VR30 engine]
5	BR	- [With 2.0L turbo gasoline engine and with BOSE system]
6	V	- [Except with 2.0L turbo gasoline engine and with BOSE system]
6	SHIELD	-
7	R	-
8	SHIELD	-
9	P	-
11	B	-
12	GR	-
13	G	-
14	B	-
15	W	-
16	BR	-

Connector No.	B60
Connector Name	WIRE TO WIRE
Connector Type	TH16FW-NH

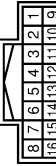

Terminal No.	Color Of Wire	Signal Name [Specification]
7	R	-
8	L	-
10	Y	-
11	SHIELD	-
12	B	-
13	W	-
14	R	-

Connector No.	B62
Connector Name	WIRE TO WIRE
Connector Type	TH80FW-CS16-TM4



Terminal No.	Color Of Wire	Signal Name [Specification]
1	BR	- [With 2.0L turbo gasoline engine and without BOSE system]
1	LG	- [With VR30 engine]
1	V	- [With 2.0L turbo gasoline engine and with BOSE system]
2	W	- [With VR30 engine]
2	SHIELD	- [With 2.0L turbo gasoline engine]
3	BR	- [With 2.0L turbo gasoline engine]
3	R	- [With VR30 engine and with BOSE system]
3	W	- [With VR30 engine and without BOSE system]
4	SHIELD	- [With VR30 engine]
4	Y	- [With 2.0L turbo gasoline engine]
5	G	- [With VR30 engine]
5	V	- [With 2.0L turbo gasoline engine]
6	BG	- [With VR30 engine]

INTELLIGENT CRUISE CONTROL

[ICC]

< WIRING DIAGRAM >

INTELLIGENT CRUISE CONTROL (VR ENGINE)

6	BR	- [With 2.0L turbo gasoline engine]
7	B	- [With 2.0L turbo gasoline engine and with BOSE system]
7	BR	- [With VR30 engine and without BOSE system]
7	W	- [With VR30 engine and with BOSE system]
7	Y	- [With 2.0L turbo gasoline engine and without BOSE system]
8	B	- [With VR30 engine and with BOSE system]
8	G	- [With 2.0L turbo gasoline engine]
8	Y	- [With VR30 engine and without BOSE system]
9	LG	- [With 2.0L turbo gasoline engine]
9	SHIELD	- [With VR30 engine]
10	V	-
11	GR	-
12	Y	-
13	R	-
14	BG	-
15	BG	- [With 2.0L turbo gasoline engine]
15	GR	- [With VR30 engine]
16	V	-
17	P	-
18	L	-
19	G	-
20	GR	-
21	R	-
23	W	-
24	BG	- [With 2.0L turbo gasoline engine]
24	V	- [With VR30 engine]
25	L	- [With 2.0L turbo gasoline engine]
25	SB	- [With VR30 engine]
26	G	- [With VR30 engine]
26	W	- [With 2.0L turbo gasoline engine]
27	R	-
28	R	-
29	LG	-
30	LG	- [With 2.0L turbo gasoline engine]
30	P	- [With VR30 engine]
31	SHIELD	-
32	L	-
32	B	- [With VR30 engine]
33	LG	- [With 2.0L turbo gasoline engine]
34	SHIELD	-
35	LG	- [With VR30 engine]
35	W	- [With 2.0L turbo gasoline engine]
36	R	-
37	P	- [With 2.0L turbo gasoline engine and without BOSE system]
37	R	- [With VR30 engine]
37	W	- [With 2.0L turbo gasoline engine and with BOSE system]
38	L	- [With 2.0L turbo gasoline engine and without BOSE system]
38	W	- [With 2.0L turbo gasoline engine and without BOSE system]
39	P	- [With VR30 engine and without BOSE system]
39	R	- [With 2.0L turbo gasoline engine]

39	W	- [With VR30 engine and with BOSE system]
40	G	-
41	L	-
42	R	-
43	SHIELD	-
44	P	- [With 2.0L turbo gasoline engine]
45	B	- [With VR30 engine]
45	G	- [With VR30 engine]
46	SHIELD	-
47	G	-
48	SB	- [With 2.0L turbo gasoline engine and without BOSE system]
48	SG	- [With 2.0L turbo gasoline engine and without BOSE system]
49	G	-
51	GR	- [With 2.0L turbo gasoline engine]
51	L	- [With VR30 engine]
52	W	- [With 2.0L turbo gasoline engine]
52	Y	- [With VR30 engine]
53	R	-
54	GR	-
55	L	-
56	V	-
57	R	-
58	LG	-
59	P	-
60	BR	-
61	L	- [With 2.0L turbo gasoline engine]
61	R	- [With VR30 engine]
62	P	- [With VR30 engine]
62	V	- [With 2.0L turbo gasoline engine]
63	L	-
64	W	-
65	R	-
66	L	- [With 2.0L turbo gasoline engine]
66	LG	- [With VR30 engine]
67	G	-
68	L	-
69	B	-
71	GR	- [With 2.0L turbo gasoline engine]
71	R	- [With VR30 engine]
72	G	- [With VR30 engine]
72	Y	- [With 2.0L turbo gasoline engine]
73	R	- [With 2.0L turbo gasoline engine]
73	SHIELD	- [With VR30 engine]
74	BG	- [With VR30 engine]
74	L	- [With 2.0L turbo gasoline engine]
75	GR	- [With VR30 engine]
75	V	- [With 2.0L turbo gasoline engine]
76	GR	- [With VR30 engine]
76	V	- [With 2.0L turbo gasoline engine]
77	P	-

78	L	-
79	G	- [With 2.0L turbo gasoline engine]
80	GR	- [With VR30 engine]
80	W	- [With VR30 engine]
81	B	- [With VR30 engine]
81	R	- [With 2.0L turbo gasoline engine]
82	G	- [With 2.0L turbo gasoline engine]
82	SHIELD	- [With VR30 engine]
83	R	- [With 2.0L turbo gasoline engine]
83	W	- [With VR30 engine]
84	BR	- [With VR30 engine]
84	SHIELD	- [With 2.0L turbo gasoline engine]
85	BG	-
85	G	- [With 2.0L turbo gasoline engine]
86	R	-
87	LG	- [With VR30 engine]
87	SHIELD	- [With 2.0L turbo gasoline engine]
88	R	-
89	LG	-
90	P	-
92	L	- [With 2.0L turbo gasoline engine]
92	W	- [With VR30 engine]
93	SHIELD	-
94	R	-
95	L	- [With 2.0L turbo gasoline engine]
95	Y	- [With VR30 engine]
96	W	-
97	L	- [With VR30 engine]
97	R	- [With 2.0L turbo gasoline engine and with BOSE system]
97	W	- [With 2.0L turbo gasoline engine and without BOSE system]
99	BR	- [With VR30 engine and with BOSE system]
99	P	- [With 2.0L turbo gasoline engine]
99	Y	- [With VR30 engine and without BOSE system]
100	BR	- [With VR30 engine]
100	W	- [With 2.0L turbo gasoline engine]

Connector No.	B72
Connector Name	WIRE TO WIRE
Connector Type	TH08FW-NH



Terminal No.	Color Of Wire	Signal Name [Specification]
1	L	-
2	SHIELD	-
3	R	-
4	L	-
5	R	-
6	R	-
7	P	-
8	SHIELD	-

Connector No.	B116
Connector Name	JOINT CONNECTOR-806
Connector Type	Z4342_4GAZA

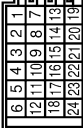

Terminal No.	Color Of Wire	Signal Name [Specification]
1	L	-
2	L	-
3	L	-
4	L	-
5	L	-
6	L	-
7	R	-
8	R	- [With Gateway]
8	V	- [Without Gateway]
9	R	- [With Gateway]
9	V	- [Without Gateway]
10	V	-

A
B
C
D
E
F
G
H
I
J
K
L
M
N
P



JROWC8956GB

INTELLIGENT CRUISE CONTROL

[ICC]

< WIRING DIAGRAM >

INTELLIGENT CRUISE CONTROL (VR ENGINE)

11	V	-	-
12	P	-	- [With 2.0L turbo gasoline engine] - [With VR30 engine]
13	R	-	-
14	SHIELD	-	-
15	SHIELD	-	-
16	SHIELD	-	-
17	SHIELD	-	-
18	SHIELD	-	-
19	L	-	-
20	L	-	-
21	L	-	-
22	R	-	-
23	R	-	-
24	R	-	-

Connector No.	B117
Connector Name	JOINT CONNECTOR-B05
Connector Type	24342_4GAZA

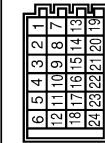

Terminal No.	Color Of Wire	Signal Name [Specification]
1	B	-
2	B	-
2	SHIELD	- [With 2.0L turbo gasoline engine] - [With VR30 engine]
3	B	-
4	SHIELD	-
5	B	-
6	B	-
7	P	-
8	P	-
8	P	-
9	P	-
9	P	-
10	P	-
10	P	-
11	P	-
11	P	-
12	P	-
13	L	-
14	L	-
15	L	-
16	L	-
17	L	-
18	L	-

19	SHIELD	-	-
20	SHIELD	-	-
21	SHIELD	-	-
22	SHIELD	-	-
23	SHIELD	-	-
24	SHIELD	-	-

Connector No.	B118
Connector Name	JOINT CONNECTOR-B04
Connector Type	24342_4GAZA

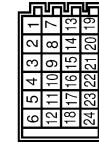

Terminal No.	Color Of Wire	Signal Name [Specification]
1	LG	- [With VR30 engine]
1	SHIELD	- [With 2.0L turbo gasoline engine]
2	LG	- [With VR30 engine]
2	SHIELD	- [With 2.0L turbo gasoline engine]
3	LG	- [With VR30 engine]
3	SHIELD	- [With 2.0L turbo gasoline engine]
4	LG	- [With VR30 engine]
4	SHIELD	- [With 2.0L turbo gasoline engine]
5	LG	- [With VR30 engine]
5	SHIELD	- [With 2.0L turbo gasoline engine]
6	LG	- [With VR30 engine]
6	SHIELD	- [With 2.0L turbo gasoline engine]
7	LG	- [With 2.0L turbo gasoline engine]
7	R	- [With VR30 engine]
8	R	-
8	LG	- [With 2.0L turbo gasoline engine]
9	R	- [With VR30 engine]
10	LG	- [With 2.0L turbo gasoline engine]
10	SHIELD	- [With VR30 engine]
11	LG	- [With 2.0L turbo gasoline engine]
11	SHIELD	- [With VR30 engine]
12	LG	- [With 2.0L turbo gasoline engine]
12	SHIELD	- [With VR30 engine]
13	L	- [With VR30 engine]
13	R	- [With 2.0L turbo gasoline engine]
14	L	- [With VR30 engine]
14	R	- [With 2.0L turbo gasoline engine]
15	L	- [With VR30 engine]

15	R	-	- [With 2.0L turbo gasoline engine]
16	L	-	- [With VR30 engine]
17	L	-	-
18	L	-	-
19	L	-	- [With 2.0L turbo gasoline engine] - [With VR30 engine]
19	SHIELD	-	- [With 2.0L turbo gasoline engine] - [With VR30 engine]
20	L	-	- [With 2.0L turbo gasoline engine]
20	SHIELD	-	- [With VR30 engine]
21	L	-	- [With 2.0L turbo gasoline engine]
21	SHIELD	-	- [With VR30 engine]
22	R	-	-
23	R	-	-
24	R	-	-

Connector No.	B120
Connector Name	JOINT CONNECTOR-B02
Connector Type	24342_4GAZA

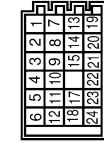

Terminal No.	Color Of Wire	Signal Name [Specification]
1	R	-
2	R	-
3	L	- [With VR30 engine]
3	R	- [With 2.0L turbo gasoline engine]
4	L	- [With VR30 engine]
4	R	- [With 2.0L turbo gasoline engine]
5	L	-
6	L	-
7	L	-
8	L	-
9	L	-
9	R	- [With 2.0L turbo gasoline engine]
10	L	- [With VR30 engine]
10	R	- [With 2.0L turbo gasoline engine]
11	R	-
12	R	-
13	W	-
14	W	-
15	W	-
17	SHIELD	-
18	B	-

19	B	-	- [With 2.0L turbo gasoline engine]
19	GR	-	- [With VR30 engine]
20	GR	-	- [With VR30 engine]
20	SHIELD	-	- [With 2.0L turbo gasoline engine]
21	B	-	- [With 2.0L turbo gasoline engine]
21	GR	-	- [With VR30 engine]
22	W	-	-
23	W	-	-
24	W	-	-

Connector No.	B123
Connector Name	JOINT CONNECTOR-B01
Connector Type	TK04FW-J

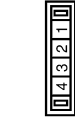

Terminal No.	Color Of Wire	Signal Name [Specification]
1	SHIELD	-
2	SHIELD	-
3	B	- [With 2.0L turbo gasoline engine]
3	SHIELD	- [With VR30 engine]
4	B	-

Connector No.	B169
Connector Name	ADAS CONTROL UNIT 2
Connector Type	1H24FB4NH

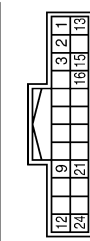

Terminal No.	Color Of Wire	Signal Name [Specification]
1	R	-
2	B	-
3	R	-
9	L	-

INTELLIGENT CRUISE CONTROL

< WIRING DIAGRAM >

[ICC]

INTELLIGENT CRUISE CONTROL (VR ENGINE)

12	R	STEERING VIBRATION MOTOR SIGNAL
13	G	WARNING BUZZER SIGNAL GROUND
15	L	CHASSIS COMMUNICATION-H
16	G	IGNITION POWER SUPPLY
21	P	ITS COMMUNICATION-L
24	L	STEERING VIBRATION MOTOR SIGNAL GROUND

Connector No.	B170
Connector Name	JOINT CONNECTOR-B13
Connector Type	INH20FC-DC

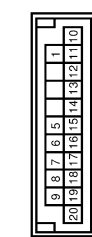

Terminal No.	Color Of Wire	Signal Name [Specification]
1	SHIELD	-
5	SHIELD	-
6	L	-
7	L	-
8	L	-
9	L	-
10	SHIELD	-
11	SHIELD	-
12	SHIELD	-
13	SHIELD	-
14	SHIELD	-
15	SHIELD	-
16	SHIELD	-
17	P	-
18	P	-
19	LG	-
20	P	-

Connector No.	E3
Connector Name	WIRE TO WIRE
Connector Type	TH24MW-AH



Terminal No.	Color Of Wire	Signal Name [Specification]
1	LG	- [With 2.0L turbo gasoline engine]
1	Y	- [With VR30 engine]
2	W	-
4	P	- [With VR30 engine]
4	SB	- [With 2.0L turbo gasoline engine]
5	L	-
6	Y	-
7	LG	-
8	BG	-
9	W	-
10	B	-
11	G	-
12	R	-
13	GR	-
14	G	-
15	LG	- [With 2.0L turbo gasoline engine]
15	V	- [With VR30 engine]
16	Y	-
17	P	-
18	BR	-
19	LG	- [With 2.0L turbo gasoline engine]
19	Y	- [With VR30 engine]
20	GR	-
21	R	- [With 2.0L turbo gasoline engine]
21	V	- [With VR30 engine]
22	L	-
23	P	-
24	B	-
24	BR	- [With VR30 engine]

Connector No.	E22
Connector Name	CHASSIS CONTROL MODULE
Connector Type	TH24FW-AH

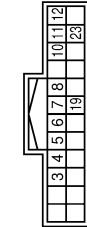

Terminal No.	Color Of Wire	Signal Name [Specification]
3	P	CAN-L [Without Gateway]
3	R	CAN-L [With Gateway]
4	L	CAN-H
5	V	DRIVE MODE SELECT SWITCH (UP) [With VR30 engine]
5	Y	DRIVE MODE SELECT SWITCH (UP) [With 2.0L turbo gasoline engine]
6	G	DRIVE MODE SELECT SW (DOWN) [With 2.0L turbo gasoline engine]
6	Y	DRIVE MODE SELECT SW (DOWN) [With VR30 engine]
7	W	CHASSIS COMMUNICATION-L
8	W	CHASSIS COMMUNICATION-L
10	BG	IGNITION POWER SUPPLY [With 2.0L turbo gasoline engine]
10	G	IGNITION POWER SUPPLY [With VR30 engine]
11	L	CHASSIS COMMUNICATION-H
12	B	GROUND [With VR30 engine]
12	B/W	GROUND [With 2.0L turbo gasoline engine]
19	BR	CHASSIS COMMUNICATION-H [With VR30 engine]
19	L	CHASSIS COMMUNICATION-H [With 2.0L turbo gasoline engine]
23	G	ESS RELAY [With VR30 engine]
23	R	ESS RELAY [With 2.0L turbo gasoline engine]

Connector No.	E25
Connector Name	WIRE TO WIRE
Connector Type	THBDFW-CS16-TM4

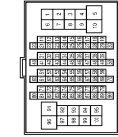

Terminal No.	Color Of Wire	Signal Name [Specification]
1	BG	-
6	V	-
7	L	-
8	BG	- [With VR30 engine]
8	BR	- [With 2.0L turbo gasoline engine]
9	B	- [With 2.0L turbo gasoline engine]
9	GR	- [With VR30 engine]
10	BR	-
11	L	-
12	P	- [With VR30 engine]
12	SHIELD	- [With 2.0L turbo gasoline engine]
13	W	- [With VR30 engine]
14	B	-
15	GR	- [With 2.0L turbo gasoline engine]
15	SB	- [With VR30 engine]
16	BR	- [With 2.0L turbo gasoline engine]
16	Y	- [With VR30 engine]
17	BR	- [With VR30 engine]
17	GR	- [With 2.0L turbo gasoline engine]
18	G	- [With 2.0L turbo gasoline engine]
19	Y	- [With VR30 engine]
31	W	- [With 2.0L turbo gasoline engine]
31	Y	- [With VR30 engine]
32	G	- [With 2.0L turbo gasoline engine]
32	GR	- [With VR30 engine]
33	L	- [With VR30 engine]
33	Y	- [With 2.0L turbo gasoline engine]
34	P	-
35	GR	-
36	R	-
37	L	- [With 2.0L turbo gasoline engine]
37	V	- [With VR30 engine]
38	L	- [With VR30 engine]
38	R	- [With 2.0L turbo gasoline engine]
39	BR	- [With 2.0L turbo gasoline engine]
39	B	- [With VR30 engine]
40	SB	-
41	LG	-
45	L	- [With 2.0L turbo gasoline engine]
45	W	- [With VR30 engine]
46	B	- [With VR30 engine]
46	Y	- [With 2.0L turbo gasoline engine]
47	G	-
48	SHIELD	-
49	R	-
50	BR	- [With VR30 engine]

A
B
C
D
E
F
G
H
I
J
K
L
M
N
P

CCS

INTELLIGENT CRUISE CONTROL

[ICC]

< WIRING DIAGRAM >

INTELLIGENT CRUISE CONTROL (VR ENGINE)

50	GR	- [With 2.0L turbo gasoline engine]
51	L	-
52	W	- [With VR30 engine]
54	P	- [With 2.0L turbo gasoline engine]
55	W	- [With 2.0L turbo gasoline engine]
55	B	- [With 2.0L turbo gasoline engine]
55	W	- [With VR30 engine]
56	BG	- [With 2.0L turbo gasoline engine]
56	SB	- [With VR30 engine]
57	BG	- [With VR30 engine]
57	W	- [With 2.0L turbo gasoline engine]
58	B/W	-
59	W	-
61	R	-
64	Y	-
65	BR	-
67	LG	-
68	BG	-
69	L	-
70	R	-
71	G	- [With 2.0L turbo gasoline engine]
71	LG	- [With VR30 engine]
72	L	- [With 2.0L turbo gasoline engine]
72	V	- [With VR30 engine]
73	G	- [With VR30 engine]
73	W	- [With 2.0L turbo gasoline engine]
74	BR	- [With VR30 engine]
74	L	- [With 2.0L turbo gasoline engine]
75	R	- [With 2.0L turbo gasoline engine]
75	V	- [With VR30 engine]
76	G	-
77	Y	-
78	LG	- [With 2.0L turbo gasoline engine and with ADAS]
78	P	- [With VR30 engine]
78	V	- [With 2.0L turbo gasoline engine and without ADAS]
79	SB	-
80	B	- [With VR30 engine]
80	G	- [With 2.0L turbo gasoline engine]
81	R	-
82	V	-
83	BR	- [With 2.0L turbo gasoline engine]
83	R	- [With VR30 engine]
84	LG	-
85	BG	-
87	G	-
88	GR	-
89	LG	-
90	G	- [With VR30 engine]
90	GR	- [With 2.0L turbo gasoline engine]
91	G	-

92	W	-
93	BG	- [With VR30 engine]
94	GR	- [With 2.0L turbo gasoline engine]
94	L	- [With 2.0L turbo gasoline engine]
95	R	-
96	W	-
97	LG	-
98	L	- [With 2.0L turbo gasoline engine]
99	LG	- [With VR30 engine]
99	P	- [With VR30 engine]
100	SHIELD	-

Connector No.	E35
Connector Name	ABS ACTUATOR AND ELECTRIC UNIT (CONTROL UNIT)
Connector Type	S4Z30FB-S24-U

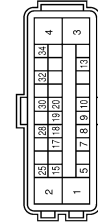

Terminal No.	Color Of Wire	Signal Name [Specification]
1	B	GROUND
2	B	GROUND
3	G	VALVE BATTERY [With VR30 engine]
3	G	VALVE BATTERY [With 2.0L turbo gasoline engine]
4	Y	MOTOR BATTERY
5	LG	STOP LAMP SW SIGNAL [With ADAS]
5	V	STOP LAMP SW SIGNAL [With ASD]
7	GR	RR LH WHEEL SENSOR SIGNAL
8	G	RR RH WHEEL SENSOR SIGNAL
9	BR	FR LH WHEEL SENSOR SIGNAL
10	GR	FR RH WHEEL SENSOR SIGNAL
13	R	VACUUM SENSOR POWER SUPPLY
15	P	CAN-L [Without Gateway]
15	R	CAN-L [With Gateway]
17	Y	RR RH WHEEL SENSOR SIGNAL
18	LG	RR RH WHEEL SENSOR POWER SUPPLY [With VR30 engine]
18	V	RR RH WHEEL SENSOR POWER SUPPLY [With VR30 engine]
19	SB	FR LH WHEEL SENSOR SIGNAL
20	BG	FR LH WHEEL SENSOR POWER SUPPLY
25	L	CAN-H
28	G	VACUUM SENSOR POWER SUPPLY
30	R	VDC OFF SW SIGNAL
32	SHIELD	VACUUM SENSOR GROUND

34	G	IGN
----	---	-----

Connector No.	E44
Connector Name	BRAKE PEDAL POSITION SWITCH
Connector Type	S20FL



Terminal No.	Color Of Wire	Signal Name [Specification]
1	G	- [With 2.0L turbo gasoline engine]
1	V	- [With VR30 engine]
2	BG	- [With 2.0L turbo gasoline engine]
2	BR	- [With VR30 engine]

Connector No.	E47
Connector Name	WIRE TO WIRE
Connector Type	THZ2MW-NH



Terminal No.	Color Of Wire	Signal Name [Specification]
1	Y	-
2	V	-
3	L	-
4	P	- [Without Gateway]
4	R	- [With Gateway]
5	W	-
6	SB	-
7	BR	-
8	W	-
9	BG	- [Without BOSE system]
9	V	- [With BOSE system]
10	V	-
11	SB	-

12	G	-
13	G	-
15	BR	-
16	P	-
17	SHIELD	-
18	L	-
19	Y	-
20	W	-
21	G	-
22	R	-
23	BR	-
24	BR	-
26	BG	-
27	LG	-
28	BR	-
29	W	-
30	Y	-
31	G	-
32	LG	-

Connector No.	E52
Connector Name	ICC BRAKE HOLD RELAY
Connector Type	MS02FL-M2-LC



Terminal No.	Color Of Wire	Signal Name [Specification]
1	Y	-
2	G	-
3	V	-
5	BR	- [With 2.0L turbo gasoline engine]
5	L	- [With VR30 engine]

INTELLIGENT CRUISE CONTROL

[ICC]

< WIRING DIAGRAM >

INTELLIGENT CRUISE CONTROL (VR ENGINE)

204	B	ECM GROUND
Connector No.	E170	WIRE TO WIRE
Connector Name	SAA36MB-BS10-S1Z2	
Connector Type		



Terminal No.	Color Of Wire	Signal Name (Specification)
10	V	
11	GR	
19	V	
20	SB	
22	B/W	
24	B	
26	L	
27	P	
28	SHIELD	
30	B	
31	P	
32	B/W	
33	V	
34	GR	
35	P	
36	B	
37	R	
38	V	
39	Y	
40	P	
41	L	
42	W	
43	B/Y	
44	V	
45	Y	
47	BG	
48	GR	

Connector No.	E171	WIRE TO WIRE
Connector Name	SAA36FB-BS10-S1Z2	
Connector Type		



Terminal No.	Color Of Wire	Signal Name (Specification)
10	V	
11	GR	
19	V	
20	SB	
22	B	
24	B	
26	L	
27	P	
28	SHIELD	
30	B	
31	P	
32	B	
33	V	
34	G	
35	R	
36	B	
37	BG	
38	LG	
39	Y	
40	P	
41	L	
42	W	
43	B	
44	L	
45	Y	
47	BG	
48	GR	

Connector No.	E172	JOINT CONNECTOR-E01
Connector Name	SGA28F1BR-J	
Connector Type		

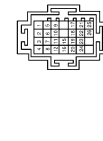

Terminal No.	Color Of Wire	Signal Name (Specification)
1	GR	
2	Y	
3	W	
4	L	
5	GR	
6	Y	
7	W	
8	L	
9	GR	
10	Y	
11	W	
12	L	
15	W	
16	BG	
17	P	
18	L	
19	W	
20	BG	
21	P	
22	L	
23	SB	
24	LG	
25	P	
26	L	

Connector No.	E173	JOINT CONNECTOR-E02
Connector Name	SGA28FDGV-J	
Connector Type		

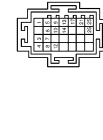

Terminal No.	Color Of Wire	Signal Name (Specification)
1	R	
3	B	
4	B	
5	G	
6	BR	
7	B	
8	B	
9	G	
10	L	
12	B	
13	G	
14	BR	
17	G	
21	G	
25	R	
26	L	

Connector No.	E219	CHASSIS CONTROL MODULE
Connector Name	1H28FW	
Connector Type		

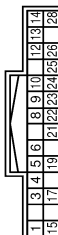

Terminal No.	Color Of Wire	Signal Name (Specification)
1	LG	ACTUATOR (PL)-L
3	BR	ACTUATOR (RR)-H
4	BG	IGNITION POWER SUPPLY
5	W	CHASSIS COMMUNICATION-L

INTELLIGENT CRUISE CONTROL

< WIRING DIAGRAM >

[ICC]

INTELLIGENT CRUISE CONTROL (VR ENGINE)

Terminal No.	Color Of Wire	Signal Name [Specification]
6	B	GROUND
8	BR	CHASSIS COMMUNICATION-H
9	Y	DRIVE MODE SELECT SW (DOWN)
10	L	CAN-H
12	G	ACTUATOR (RH)
13	G	ESS RELAY
14	L	ACTUATOR (RL)
15	Y	ACTUATOR (RH)
17	V	ACTUATOR (LH)
19	L	CHASSIS COMMUNICATION-H
21	W	CHASSIS COMMUNICATION-L
22	V	DRIVE MODE SELECT SWITCH (UP)
23	B	GROUND
24	P	CAN-L [Without Gateway]
24	R	CAN-L [With Gateway]
25	G	IGNITION POWER SUPPLY
26	V	ACTUATOR (RLH)
28	R	ACTUATOR (RHL)

Connector No.	F2
Connector Name	A/T ASSEMBLY
Connector Type	IRK1D1G-DGY



Terminal No.	Color Of Wire	Signal Name [Specification]
1	L	IGNITION POWER SUPPLY
2	P	BATTERY POWER SUPPLY (MEMORY BACK-UP)
3	L	CAN-H
4	R	CAN-L
5	BR	GROUND
6	GR	IGNITION POWER SUPPLY
7	BG	BACK-UP LAMP RELAY
8	P	CAN-L
9	V	STARTER RELAY
10	B	GROUND

Connector No.	F100
Connector Name	TCM
Connector Type	SP1D1FG



Terminal No.	Color Of Wire	Signal Name [Specification]
1	-	IGNITION POWER SUPPLY
2	-	BATTERY POWER SUPPLY (MEMORY BACK-UP)
3	-	CAN-H
4	-	K-LINE
5	-	GROUND
6	-	IGNITION POWER SUPPLY
7	-	BACK-UP LAMP RELAY
8	-	CAN-L
9	-	STARTER RELAY
10	-	GROUND

Connector No.	M19
Connector Name	WIRE TO WIRE
Connector Type	TH80MM-CS1.6-TM4



Terminal No.	Color Of Wire	Signal Name [Specification]
1	Y	-
2	G	-
3	SB	-
5	Y	-
7	W	-
10	BG	-
11	BR	-
12	LG	-
13	GR	-
14	R	-

Terminal No.	Color Of Wire	Signal Name [Specification]
15	L	-
16	V	-
18	W	-
19	BR	-
20	W	-
24	R	- [With 2.0L turbo gasoline engine]
24	V	- [With VR30 engine]
25	P	- [With 2.0L turbo gasoline engine]
25	W	- [With VR30 engine]
26	G	-
29	R	-
27	R	-
28	R	-
31	BR	-
32	B	-
33	B	-
34	V	-
35	P	-
36	W	-
37	SB	-
38	LG	-
40	P	-
41	G	-
42	BR	-
43	BR	-
44	BR	-
46	BG	-
50	W	-
51	Y	-
52	V	-
53	LG	-
54	R	-
55	R	-
58	V	-
59	BG	-
60	G	-
61	G	-
62	BG	-
63	BR	-
64	Y	-
66	R	-
70	LG	-
71	W	-
72	B	-
73	W	-
74	L	-
75	W	-
76	BR	-
77	B	-
78	SB	-
79	W	-

Terminal No.	Color Of Wire	Signal Name [Specification]
81	B	-
82	R	-
83	BG	-
84	L	-
85	W	-
86	B	-
88	G	-
89	V	-
91	GR	-
93	GR	-
94	GR	-
96	W	-
98	BR	- [With VR30 engine and with BOSE system]
98	Y	- [Except with VR30 engine and with BOSE system]

Connector No.	M20
Connector Name	WIRE TO WIRE
Connector Type	TH16MM-NH



Terminal No.	Color Of Wire	Signal Name [Specification]
7	W	-
8	L	-
10	Y	-
11	SHIELD	-
12	B	-
13	W	-
14	R	-

A
B
C
D
E
F
G
H
I
J
K
L
M
N
P

INTELLIGENT CRUISE CONTROL

[ICC]

< WIRING DIAGRAM >

INTELLIGENT CRUISE CONTROL (VR ENGINE)

Connector No.	M22
Connector Name	WIRE TO WIRE
Connector Type	TH80MVF-CS16-TM4



Terminal No.	Color Of Wire	Signal Name (Specification)
1	LG	-
2	L	- [With VR30 engine]
3	SHIELD	- [With 2.0L turbo gasoline engine]
4	BR	- [With 2.0L turbo gasoline engine]
5	R	- [With VR30 engine]
6	SHIELD	- [With VR30 engine]
7	Y	- [With 2.0L turbo gasoline engine]
8	G	- [With VR30 engine]
9	V	- [With 2.0L turbo gasoline engine]
10	BG	- [With VR30 engine]
11	GR	- [With 2.0L turbo gasoline engine]
12	V	- [With VR30 engine]
13	LG	-
14	LG	-
15	BR	- [With 2.0L turbo gasoline engine]
16	P	- [With VR30 engine]
17	SB	- [With DCM]
18	V	- [Without DCM]
19	Y	-
20	L	-
21	G	-
22	GR	-
23	R	-
24	BG	- [With 2.0L turbo gasoline engine]
25	V	- [With VR30 engine]
26	L	- [With 2.0L turbo gasoline engine]
27	R	- [With VR30 engine]
28	LG	-
29	W	-
30	SB	-
31	SHIELD	-
32	B	-
33	B	- [With VR30 engine]
34	SHIELD	- [With 2.0L turbo gasoline engine]
35	LG	- [With VR30 engine]
36	W	- [With 2.0L turbo gasoline engine]
37	R	- [With VR30 engine]
38	V	- [With 2.0L turbo gasoline engine]
39	L	- [With 2.0L turbo gasoline engine and without BOSE system]
40	G	- [With VR30 engine and with BOSE system]
41	L	-
42	R	-
43	SHIELD	-
44	P	-
45	B	- [With 2.0L turbo gasoline engine]
46	G	- [With VR30 engine]
47	G	-
48	BG	-
49	SB	- [With VR30 engine and with BOSE system]
50	L	- [With 2.0L turbo gasoline engine and without BOSE system]
51	G	- [With VR30 engine]
52	V	- [With 2.0L turbo gasoline engine]
53	Y	- [With VR30 engine]
54	GR	-
55	L	-
56	P	-
57	R	-
58	LG	-
59	SB	-
60	BR	-
61	L	- [With 2.0L turbo gasoline engine]
62	P	- [With VR30 engine]

62	V	- [With VR30 engine]
63	L	-
64	W	-
65	R	-
66	L	- [With 2.0L turbo gasoline engine]
67	G	- [With VR30 engine]
68	L	-
69	P	-
70	GR	- [With 2.0L turbo gasoline engine]
71	R	- [With VR30 engine]
72	V	- [With VR30 engine]
73	LG	- [With 2.0L turbo gasoline engine]
74	L	- [With VR30 engine]
75	P	-
76	SB	- [With 2.0L turbo gasoline engine]
77	Y	- [With VR30 engine]
78	L	-
79	G	-
80	GR	- [With 2.0L turbo gasoline engine]
81	B	- [With VR30 engine]
82	R	- [With 2.0L turbo gasoline engine]
83	G	- [With 2.0L turbo gasoline engine]
84	SHIELD	- [With VR30 engine]
85	W	-
86	BR	- [With VR30 engine]
87	G	- [With 2.0L turbo gasoline engine]
88	R	-
89	LG	-
90	SB	-
91	L	-
92	W	- [With 2.0L turbo gasoline engine]
93	SHIELD	- [With VR30 engine]
94	R	-
95	L	- [With 2.0L turbo gasoline engine]
96	W	- [With VR30 engine]
97	L	- [With 2.0L turbo gasoline engine]
98	R	- [With 2.0L turbo gasoline engine]

99	BR	- [With VR30 engine and with BOSE system]
100	P	- [With 2.0L turbo gasoline engine]
101	Y	- [With VR30 engine and without BOSE system]
102	BR	- [With VR30 engine]
103	W	- [With 2.0L turbo gasoline engine]

Connector No.	M24
Connector Name	CAN GATEWAY
Connector Type	TH12FW-NH

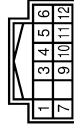

Terminal No.	Color Of Wire	Signal Name (Specification)
1	L	CAN-H (CAN COMMUNICATION CIRCUIT 1)
2	L	CAN-H (CAN COMMUNICATION CIRCUIT 1)
3	W	BATTERY POWER SUPPLY
4	L	CAN-H (CAN COMMUNICATION CIRCUIT 2)
5	B	GROUND
6	L	CAN-H (CAN COMMUNICATION CIRCUIT 2)
7	P	CAN-L (CAN COMMUNICATION CIRCUIT 1)
8	R	IGNITION POWER SUPPLY [With VR30 engine]
9	W	IGNITION POWER SUPPLY [With 2.0L turbo gasoline engine]
10	R	CAN-L (CAN COMMUNICATION CIRCUIT 2)
11	B	GROUND
12	R	CAN-L (CAN COMMUNICATION CIRCUIT 2)

Connector No.	M25
Connector Name	DATA LINK CONNECTOR
Connector Type	BD16FW

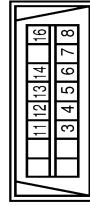

INTELLIGENT CRUISE CONTROL

[ICC]

< WIRING DIAGRAM >

INTELLIGENT CRUISE CONTROL (VR ENGINE)

Terminal No.	Color Of Wire	Signal Name [Specification]
3	LG	M_CAN_L
4	B	EARTH
5	B	CAN-H
6	L	KLIME [With 2.0L turbo gasoline engine]
7	W	KLIME [With VR30 engine]
8	W	ICN_SW
11	SB	M_CAN_H
12	R	CAN-L
13	L	CAN-H
14	P	CAN-L
16	W	POWER

Connector No.	W39
Connector Name	WIRE TO WIRE
Connector Type	TH32PW-NH



1	2	3	4	5	6	7	8	9	10	11	12	13	14	15	16	17
---	---	---	---	---	---	---	---	---	----	----	----	----	----	----	----	----

Terminal No.	Color Of Wire	Signal Name [Specification]
20	L	-
21	G	-
22	R	-
23	BR	-
26	Y	-
27	LG	-
28	BR	-
29	W/B	-
30	Y	-
31	W	-
32	LG	-

Connector No.	M40
Connector Name	WIRE TO WIRE
Connector Type	TH80MW-CS1G-TM4



1	2	3	4	5	6	7	8	9	10	11	12	13	14	15	16	17
---	---	---	---	---	---	---	---	---	----	----	----	----	----	----	----	----

Terminal No.	Color Of Wire	Signal Name [Specification]
6	W/B	-
7	V	-
8	RG	- [With VR30 engine]
8	BR	- [With 2.0L turbo gasoline engine]
9	LG	- [With VR30 engine]
9	P	- [With 2.0L turbo gasoline engine]
10	W	-
11	W	- [With VR30 engine]
11	Y	- [With VR30 engine]
12	B	- [With 2.0L turbo gasoline engine]
12	BR	- [With 2.0L turbo gasoline engine]
13	GN	- [With VR30 engine]
13	SHIELD	- [With 2.0L turbo gasoline engine]
14	B	-
15	RG	- [With 2.0L turbo gasoline engine]
15	SB	- [With VR30 engine]
16	B	- [With VR30 engine]
16	BR	- [With 2.0L turbo gasoline engine]
17	LG	-
18	B	- [With VR30 engine]
18	W/B	- [With 2.0L turbo gasoline engine]
19	Y	-

Terminal No.	Color Of Wire	Signal Name [Specification]
1	W/B	-
2	SB	-
3	L	-
4	P	- [Without Gateway]
4	R	- [With Gateway]
5	RR	-
6	SB	-
7	L	-
8	W	-
9	P	- [Without BOSE system]
9	V	- [With BOSE system]
10	V	-
11	SB	-
12	G	-
13	G	-
15	R	-
16	SB	-
17	SHIELD	-
18	W	-
19	Y	-

Terminal No.	Color Of Wire	Signal Name [Specification]
73	R	- [With VR30 engine]
73	W	- [With 2.0L turbo gasoline engine]
74	BR	- [With VR30 engine]
74	L	- [With 2.0L turbo gasoline engine]
75	B	- [With VR30 engine]
75	R	- [With 2.0L turbo gasoline engine]
76	W/B	-
77	SB	-
78	G	- [With VR30 engine]
78	LG	- [With 2.0L turbo gasoline engine]
79	R	-
80	B	- [With VR30 engine]
80	G	- [With 2.0L turbo gasoline engine]
81	R	-
82	LG	-
83	BR	- [With 2.0L turbo gasoline engine]
83	R	- [With VR30 engine]
84	V	-
86	V	-
87	G	-
88	R	-
89	V	-
90	G	- [With VR30 engine]
90	V	- [With 2.0L turbo gasoline engine]
91	W	-
92	G	- [With VR30 engine]
92	W	- [With 2.0L turbo gasoline engine]
93	BR	-
94	GR	- [With VR30 engine]
94	L	- [With 2.0L turbo gasoline engine]
95	BR	- [With VR30 engine]
95	R	- [With 2.0L turbo gasoline engine]
96	W	-
97	LG	-
98	Y	-
99	BR	- [With VR30 engine]
99	LG	- [With 2.0L turbo gasoline engine]
100	SHIELD	-

Terminal No.	Color Of Wire	Signal Name [Specification]
31	W	-
32	G	- [With 2.0L turbo gasoline engine]
32	V	- [With VR30 engine]
33	L	- [With VR30 engine]
33	Y	- [With 2.0L turbo gasoline engine]
34	P	-
35	B	-
35	RG	-
36	G	- [With VR30 engine]
37	B	- [With 2.0L turbo gasoline engine]
37	L	- [With 2.0L turbo gasoline engine]
38	L	- [With VR30 engine]
38	R	- [With 2.0L turbo gasoline engine]
39	R	- [With 2.0L turbo gasoline engine]
39	Y	- [With VR30 engine]
40	GR	-
41	L	-
45	L	- [With 2.0L turbo gasoline engine]
45	W	- [With VR30 engine]
46	G	- [With VR30 engine]
46	Y	- [With 2.0L turbo gasoline engine]
47	RG	- [With 2.0L turbo gasoline engine]
47	R	- [With VR30 engine]
48	SHIELD	-
49	B	- [With VR30 engine]
49	G	- [With 2.0L turbo gasoline engine]
50	B	- [With 2.0L turbo gasoline engine]
50	BR	- [With VR30 engine]
51	L	-
52	W	-
54	SB	- [With 2.0L turbo gasoline engine]
54	Y	- [With VR30 engine]
55	B	- [With 2.0L turbo gasoline engine]
55	P	- [With VR30 engine]
56	RG	- [With VR30 engine]
56	GR	- [With 2.0L turbo gasoline engine]
57	GR	- [With VR30 engine]
57	P	- [With 2.0L turbo gasoline engine]
58	B	-
59	SB	-
61	W/B	-
64	Y	-
65	R	-
67	LG	-
68	RG	-
69	L	-
70	R	-
71	V	- [With VR30 engine]
71	W	- [With 2.0L turbo gasoline engine]
72	L	- [With 2.0L turbo gasoline engine]
72	LG	- [With VR30 engine]

A
B
C
D
E
F
G
H
I
J
K
L
M
N
P



JROWC8964GB

INTELLIGENT CRUISE CONTROL

[ICC]

< WIRING DIAGRAM >

INTELLIGENT CRUISE CONTROL (VR ENGINE)

Connector No.	M158
Connector Name	COMBINATION METER
Connector Type	TH12FW-NH



Terminal No.	Color Of Wire	Signal Name [Specification]
41	L	CAN-H
42	P	CAN-L
43	B	ILLUMINATION CONTROL SIGNAL
44	Y	FUEL LEVEL SENSOR GROUND
45	W	BATTERY POWER SUPPLY
46	BG	IGNITION SIGNAL [With 2.0L turbo gasoline engine models]
46	R	IGNITION SIGNAL [With VR30DDTT engine models]
47	SB	AV COMMUNICATION SIGNAL (H)
48	LG	AV COMMUNICATION SIGNAL (L)
51	BR	FUEL LEVEL SENSOR SIGNAL
52	B	GROUND

Connector No.	M177
Connector Name	STEERING ANGLE SENSOR
Connector Type	TH08FW-NH



Terminal No.	Color Of Wire	Signal Name [Specification]
1	B	GROUND
2	P	CAN-L [Without Gateway]
4	R	CAN-L [With Gateway]
5	L	CAN-H

Connector No.	M185
Connector Name	RESISTOR
Connector Type	M02FBR-LC



Terminal No.	Color Of Wire	Signal Name [Specification]
1	LG	-
2	B	-

Connector No.	M107
Connector Name	DRIVER ASSISTANCE BUZZER
Connector Type	MS02FW-CS



Terminal No.	Color Of Wire	Signal Name [Specification]
1	R	-
2	G	-

Connector No.	M133
Connector Name	FUSE BLOCK (J/B)
Connector Type	TH40FW-NH

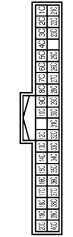

Terminal No.	Color Of Wire	Signal Name [Specification]
10C	V	-
12C	L	-
13C	L	-
14C	Y	-
15C	R	-
16C	R	-
17C	L	-
18C	BG	- [Without DRPO]
18C	P	- [With DRPO]
19C	B	-
1C	R	-
20C	W	-
21C	L	-
22C	L	-
23C	L	-
25C	LG	-
26C	SB	-
27C	P	-
28C	W	-
29C	W	-
2C	R	-
30C	R	-
31C	W	-
32C	B	-
32C	B	- [With VR30 engine]
32C	B	- [With 2.0L turbo gasoline engine]
32C	W/B	-
32C	SB	-
36C	R	-
37C	W	-
38C	SB	-
39C	V	-
3C	P	-
40C	G	-
4C	P	-
5C	P	-

6C	G	-
7C	G	-
8C	G	-
9C	V	-

Connector No.	M137
Connector Name	JOINT CONNECTOR-M10
Connector Type	24342_46A2A

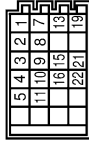

Terminal No.	Color Of Wire	Signal Name [Specification]
1	B	-
2	B	-
3	B	-
4	B	-
5	B	-
7	B	-
8	B	-
9	B	-
10	B	-
11	B	-
13	L	-
15	L	-
16	L	-
19	R	-
21	R	-
22	R	-

INTELLIGENT CRUISE CONTROL

< WIRING DIAGRAM >

[ICC]

INTELLIGENT CRUISE CONTROL (VR ENGINE)

Connector No.	M173
Connector Name	JOINT CONNECTOR-M03
Connector Type	24342_4GA2A

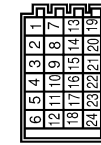

Terminal No.	Color Of Wire	Signal Name [Specification]
1	L	-
2	L	-
3	L	-
4	L	-
5	L	-
6	L	-
7	R	-
8	R	-
9	R	-
10	R	-
11	R	-
12	R	-
13	SB	-
14	SB	-
15	SB	-
16	L	- [With 2.0L turbo gasoline engine]
17	L	- [With VR30 engine]
18	L	- [With 2.0L turbo gasoline engine]
19	BR	- [With VR30 engine]
20	BR	- [With 2.0L turbo gasoline engine]
21	LG	- [With VR30 engine]
22	R	- [With 2.0L turbo gasoline engine]
23	R	- [With VR30 engine]
24	R	- [With 2.0L turbo gasoline engine]

Connector No.	M174
Connector Name	JOINT CONNECTOR-M04
Connector Type	24342_4GA2A

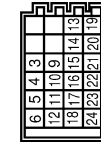

Terminal No.	Color Of Wire	Signal Name [Specification]
3	L	-
4	L	-
5	L	-
6	L	-
9	Y	-
10	Y	-
11	Y	-
12	Y	-
13	SB	-
14	SB	-
15	SB	-
16	SB	-
17	SB	-
18	SB	-
19	LG	-
20	LG	-
21	LG	-
22	LG	-
23	LG	-
24	LG	-

Connector No.	M175
Connector Name	JOINT CONNECTOR-M05
Connector Type	NH20FL-DC

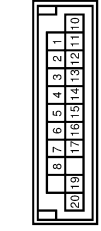

Terminal No.	Color Of Wire	Signal Name [Specification]
1	L	-
2	L	-
3	L	-
4	L	-
5	L	-
6	L	-
7	L	-
8	L	-
10	P	-
11	P	-
12	P	-
13	P	-
14	P	-
15	P	-
16	P	-
17	P	-
19	W	-
20	W	-

Connector No.	M183
Connector Name	JOINT CONNECTOR-M11
Connector Type	TK04FW-J

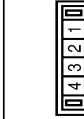

Terminal No.	Color Of Wire	Signal Name [Specification]
1	L	-
2	L	-
3	L	-
4	L	-

Connector No.	M184
Connector Name	JOINT CONNECTOR-M12
Connector Type	TK04FW-J



Terminal No.	Color Of Wire	Signal Name [Specification]
1	W	-
2	W	-
3	W	-
4	W	-

Connector No.	M190
Connector Name	COMBINATION SWITCH (SPRAL CABLE)
Connector Type	TH24FW-NH-Y-CPA



Terminal No.	Color Of Wire	Signal Name [Specification]
28	Y/R	-
29	Y	-
30	Y/B	-
31	SB	-
32	B	-
33	W/B	-
34	P	-
36	B/G	-

A
B
C
D
E
F
G
H
I
J
K
L
M
N
P

INTELLIGENT CRUISE CONTROL (VR ENGINE)

37	G	-
38	R	-
39	Y	-
41	B	-
42	B	-
43	LG	-
45	L	-
46	R	-

Connector No.	NB02
Connector Name	COMBINATION SWITCH (SPIRAL CABLE)
Connector Type	SUMTCM01H-12



Terminal No.	Color Of Wire	Signal Name (Specification)
13	-	-
14	-	-
15	-	-
16	-	-
17	-	-
18	-	-
19	-	-
20	-	-
21	-	-
22	-	-
23	-	-
24	-	-

JROWC9397GB

INTELLIGENT CRUISE CONTROL

[ICC]

< WIRING DIAGRAM >

2.0L TURBO GASOLINE ENGINE

INTELLIGENT CRUISE CONTROL (2.0L TURBO GASOLINE ENGINE)

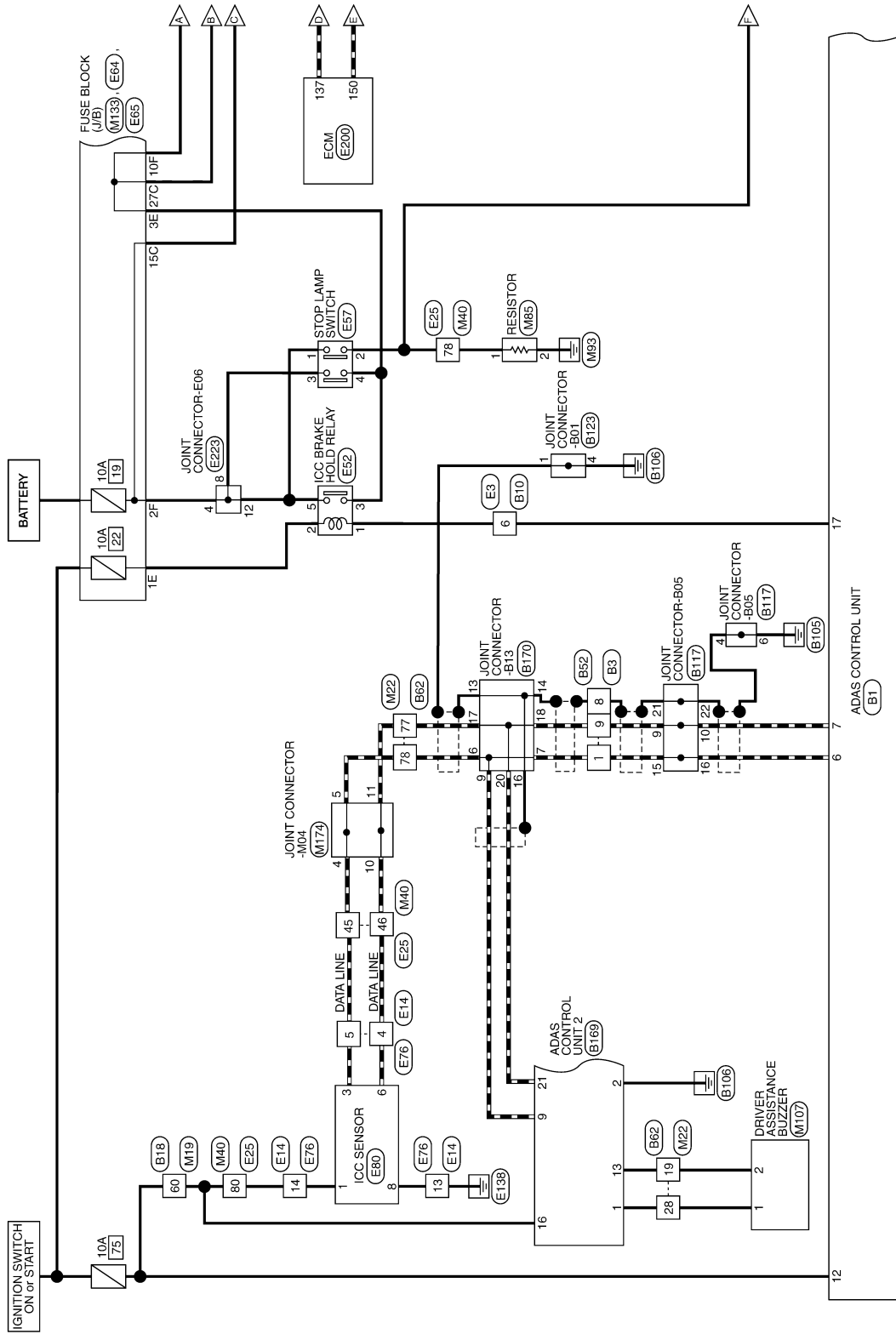

*: This connector is not shown in "Harness Layout".

2016/04/07

JROWC8966GB

A
B
C
D
E
F
G
H
I
J
K
L
M
N
P

CCS

INTELLIGENT CRUISE CONTROL

< WIRING DIAGRAM >

[ICC]

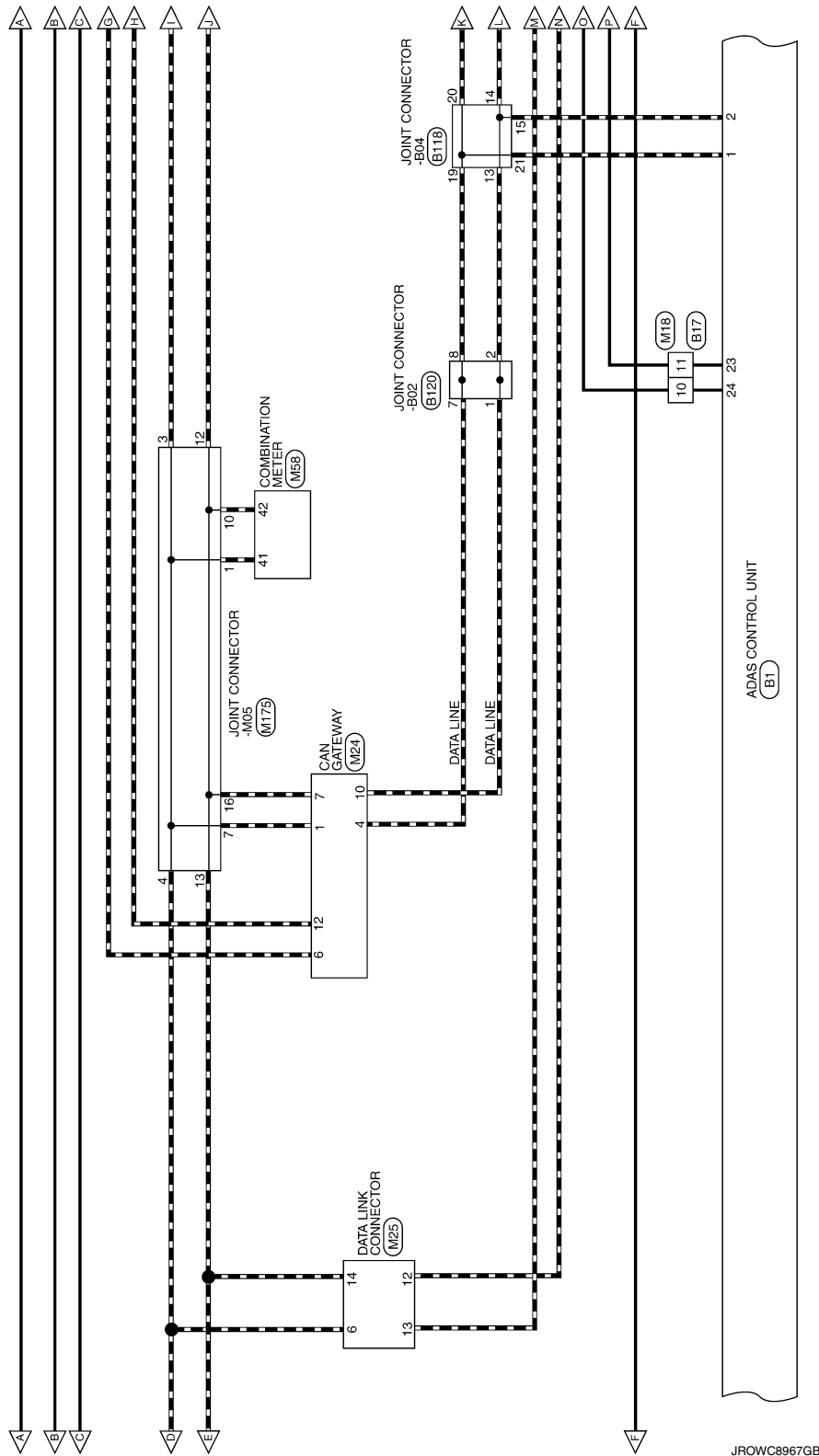

JROWC8967GB

INTELLIGENT CRUISE CONTROL

[ICC]

< WIRING DIAGRAM >

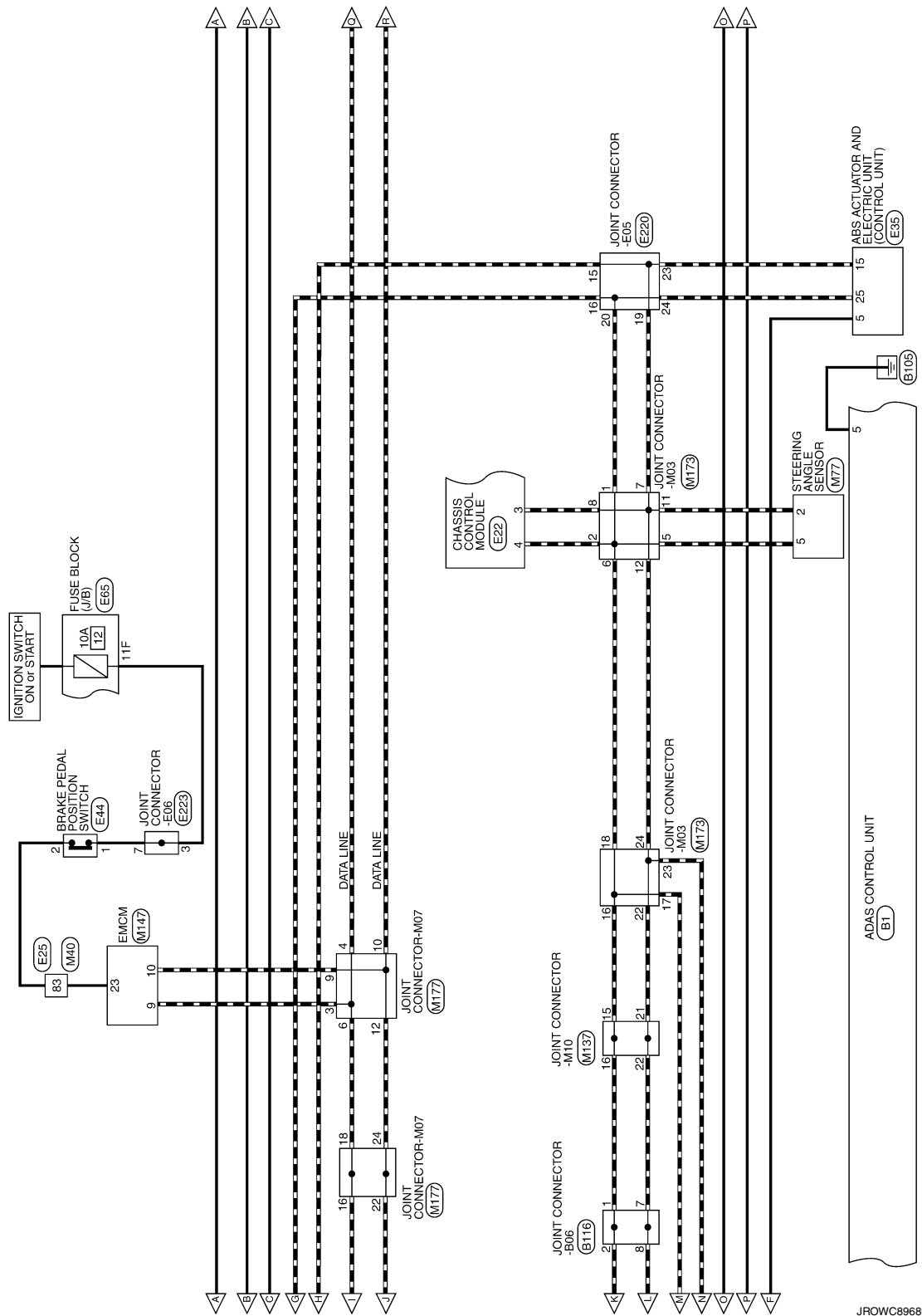

JROWC8968GB

A
B
C
D
E
F
G
H
I
J
K
L
M
N
P

CCS

INTELLIGENT CRUISE CONTROL

< WIRING DIAGRAM >

[ICC]

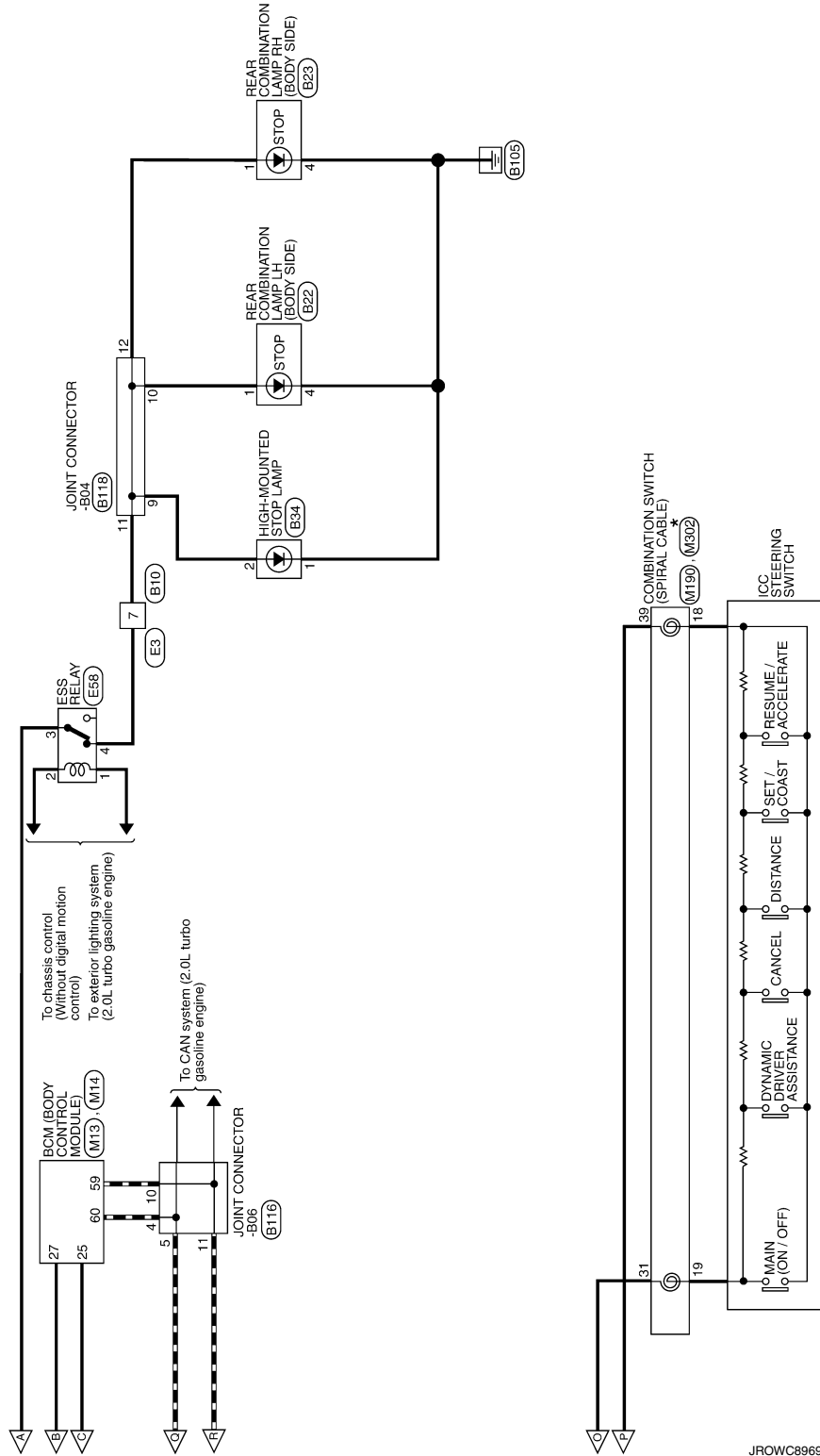

INTELLIGENT CRUISE CONTROL

< WIRING DIAGRAM >

[ICC]

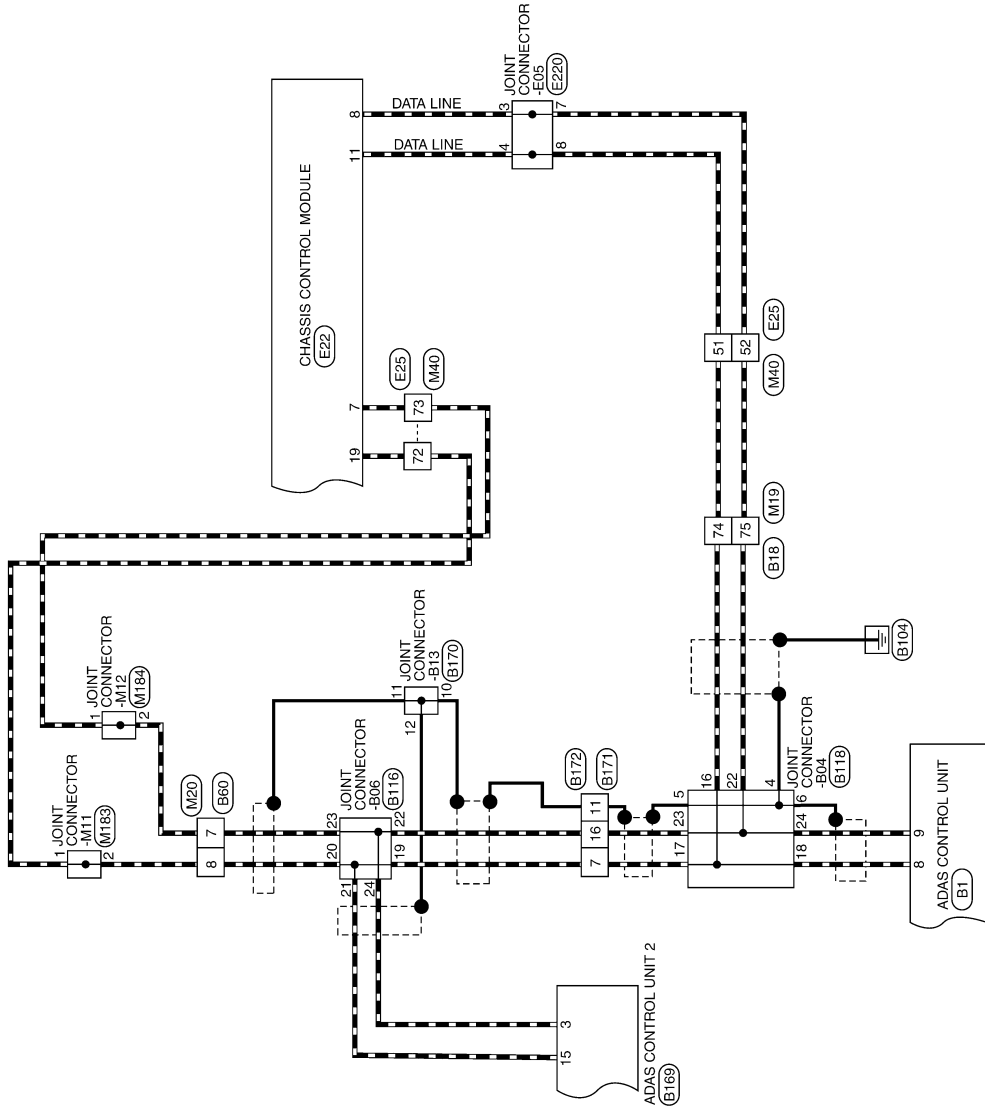

A
B
C
D
E
F
G
H
I
J
K
L
M
N
P

CCS

JROWC8970GB

INTELLIGENT CRUISE CONTROL

INTELLIGENT CRUISE CONTROL (2.0L TURBO GASOLINE ENGINE)

Connector No.	B1
Connector Name	ADAS CONTROL UNIT
Connector Type	TH24FW-NH

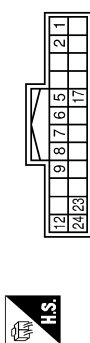

8	SHIELD	-
9	P	-
11	B	-
12	GR	-
13	G	-
14	B	-
15	W	-
16	BR	-

Connector No.	B10
Connector Name	WIRE TO WIRE
Connector Type	TH24FW-NH

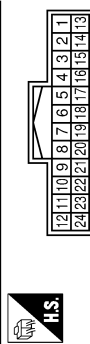

23	V	-
24	B	-
24	R	-

Connector No.	B17
Connector Name	WIRE TO WIRE
Connector Type	NS16FW-CS

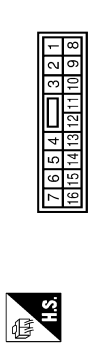

Terminal No.	Color Of Wire	Signal Name [Specification]
10	SB	-
11	Y	-
12	GR	-

Connector No.	B18
Connector Name	WIRE TO WIRE
Connector Type	TH80FW-CS16-TM4



Terminal No.	Color Of Wire	Signal Name [Specification]
1	Y	-
2	G	-
3	L	-
5	Y	-
7	V	-
10	BG	-
11	BG	-
12	LG	-
13	GR	-
14	R	-
15	L	-

16	V	-
18	W	-
19	BR	-
20	W	-
22	R	-
23	V	-
24	R	- [With 2.0L turbo gasoline engine]
24	Y	- [With VR30 engine]
25	V	- [With 2.0L turbo gasoline engine]
26	W	- [With VR30 engine]
27	G	-
28	R	-
28	R	-
31	B	- [With VR30 engine]
31	BR	- [With 2.0L turbo gasoline engine]
32	B	-
33	B	-
34	LG	-
35	P	-
36	W	-
37	SB	-
38	LG	-
40	P	-
41	SB	-
42	BR	-
43	BG	-
44	BG	-
46	R	-
50	W	-
51	SB	-
52	V	-
53	LG	-
54	R	-
55	R	-
58	V	-
58	GR	-
60	G	-
61	G	-
62	BG	-
63	BR	-
64	R	-
68	R	-
70	R	-
71	W	-
72	B	-
73	W	-
74	L	-
75	R	-
76	BR	-

INTELLIGENT CRUISE CONTROL

[ICC]

< WIRING DIAGRAM >

INTELLIGENT CRUISE CONTROL (2.0L TURBO GASOLINE ENGINE)

77	B	-	-	-	-
78	SB	-	-	-	-
79	W	-	-	-	-
81	B	-	-	-	-
82	R	-	-	-	-
83	BG	-	-	-	-
84	L	-	-	-	-
85	B	-	-	-	-
86	G	-	-	-	-
88	V	-	-	-	-
89	GR	-	-	-	-
91	GR	-	-	-	-
93	GR	-	-	-	-
94	GR	-	-	-	-
95	Y	-	-	-	-
98	BR	-	-	-	-
98	Y	-	-	-	-

Connector No.	B22
Connector Name	REAR COMBINATION LAMP U (BODY SIDE)
Connector Type	NSD4MW-CS



Connector No.	B23
Connector Name	REAR COMBINATION LAMP R (BODY SIDE)
Connector Type	NSD4MW-CS



Terminal No.	Color Of Wire	Signal Name [Specification]
1	LG	-
2	R	-
3	V	-
4	B	-

Connector No.	B34
Connector Name	HIGH MOUNTED STOP LAMP
Connector Type	TK02MBR-P



Terminal No.	Color Of Wire	Signal Name [Specification]
1	LG	-
2	P	-
3	SB	-
4	B	-

Connector No.	B52
Connector Name	WIRE TO WIRE
Connector Type	NS16AW-CS



Terminal No.	Color Of Wire	Signal Name [Specification]
1	L	-
4	B	-
4	BR	-
5	BR	-
5	Y	-
6	SHIELD	-
7	R	-
8	SHIELD	-
9	P	-
11	B	-
12	GR	-
13	G	-
14	B	-
15	W	-
16	BR	-

Connector No.	B60
Connector Name	WIRE TO WIRE
Connector Type	TH16FW-WH



Terminal No.	Color Of Wire	Signal Name [Specification]
7	R	-
8	L	-
10	Y	-
11	SHIELD	-
12	B	-

13	W	-
14	R	-

Connector No.	B62
Connector Name	WIRE TO WIRE
Connector Type	TH80FW-CS16-TM4



Terminal No.	Color Of Wire	Signal Name [Specification]
1	BR	-
1	LG	-
1	W	-
2	L	-
2	SHIELD	-
3	BR	-
3	R	-
3	W	-
4	SHIELD	-
4	Y	-
5	G	-
5	V	-
6	BG	-
6	BR	-
7	B	-
7	BR	-
7	W	-
7	Y	-
8	B	-
8	G	-
8	Y	-
9	LG	-
9	SHIELD	-
10	V	-
11	GR	-
12	Y	-
13	R	-
14	BG	-
15	BG	-
15	GR	-
16	V	-
17	P	-

A
B
C
D
E
F
G
H
I
J
K
L
M
N
P

CCS

JROWC8972GB

INTELLIGENT CRUISE CONTROL

[ICC]

< WIRING DIAGRAM >

INTELLIGENT CRUISE CONTROL (2.0L TURBO GASOLINE ENGINE)

Connector No.	B118
Connector Name	JOINT CONNECTOR-B04
Connector Type	24342_4GAZA



6	5	4	3	2	1
12	11	10	9	8	7
18	17	16	15	14	13
24	23	22	21	20	19

21	L	-	-	[With 2.0L turbo gasoline engine]
22	R	SHIELD	-	[With VR30 engine]
23	R	-	-	-
24	R	-	-	-

Connector No.	B120
Connector Name	JOINT CONNECTOR-B02
Connector Type	24342_4GAZA



6	5	4	3	2	1
12	11	10	9	8	7
18	17	16	15	14	13
24	23	22	21	20	19

Terminal No.	Color Of Wire	Signal Name [Specification]
1	R	-
2	R	-
3	L	- [With VR30 engine]
4	L	- [With 2.0L turbo gasoline engine]
5	L	- [With VR30 engine]
6	L	- [With 2.0L turbo gasoline engine]
7	R	-
8	L	-
9	L	- [With VR30 engine]
10	R	- [With 2.0L turbo gasoline engine]
11	R	- [With VR30 engine]
12	R	-
13	W	-
14	W	-
15	W	-
17	SHIELD	-
18	B	-
19	B	- [With 2.0L turbo gasoline engine]
20	GR	- [With VR30 engine]
21	B	- [With 2.0L turbo gasoline engine]
22	W	- [With VR30 engine]
23	W	-

24	W	-	-
----	---	---	---



Connector No.	B123
Connector Name	JOINT CONNECTOR-B01
Connector Type	TK04FW-J

0	4	3	2	1	0
---	---	---	---	---	---

Terminal No.	Color Of Wire	Signal Name [Specification]
1	SHIELD	-
2	SHIELD	-
3	B	- [With 2.0L turbo gasoline engine]
4	B	- [With VR30 engine]

Connector No.	B169
Connector Name	ADAS CONTROL UNIT 2
Connector Type	TH24FB-NH



1	2	3	4	5	6	7	8	9	10	11	12	13
17	16	15	14	13	12	11	10	9	8	7	6	5
24	23	22	21	20	19	18	17	16	15	14	13	12

Terminal No.	Color Of Wire	Signal Name [Specification]
1	R	WARNING BUZZER SINGAL
2	B	GROUND
3	R	CHASSIS COMMUNICATION-L
9	L	ITS COMMUNICATION-H
12	R	STEERING VIBRATION MOTOR SIGNAL
13	G	WARNING BUZZER SINGAL GROUND
15	L	CHASSIS COMMUNICATION-H
16	G	IGNITION POWER SUPPLY
21	P	ITS COMMUNICATION-L
24	L	STEERING VIBRATION MOTOR SIGNAL GROUND

Connector No.	B170
Connector Name	JOINT CONNECTOR-B13
Connector Type	NH20FG-DC



1	2	3	4	5	6	7	8	9	10	11	12	13	14	15	16	17	18	19	20
---	---	---	---	---	---	---	---	---	----	----	----	----	----	----	----	----	----	----	----

Terminal No.	Color Of Wire	Signal Name [Specification]
1	SHIELD	-
5	SHIELD	-
6	L	-
7	L	-
8	L	-
9	L	-
10	SHIELD	-
11	SHIELD	-
12	SHIELD	-
13	SHIELD	-
14	SHIELD	-
15	SHIELD	-
16	SHIELD	-
17	P	-
18	P	-
19	P	-
20	P	-

Connector No.	B171
Connector Name	WIRE TO WIRE
Connector Type	NS16MMZ-CS



1	2	3	4	5	6	7		
8	9	10	11	12	13	14	15	16

Terminal No.	Color Of Wire	Signal Name [Specification]
4	SHIELD	-
5	V	-
6	L	-

A B C D E F G H I J K L M N P

CCS

JROWC8974GB

INTELLIGENT CRUISE CONTROL

[ICC]

< WIRING DIAGRAM >

INTELLIGENT CRUISE CONTROL (2.0L TURBO GASOLINE ENGINE)

7	L	-
10	P	-
11	SHIELD	-
12	R	-
13	SHIELD	-
14	R	-
15	L	-
16	R	-

Connector No.	B172
Connector Name	WIRE TO WIRE
Connector Type	MS16PW/CS



7	6	5	4	3	2	1
16	15	14	13	12	11	10
9	8	7	6	5	4	3

Terminal No.	Color Of Wire	Signal Name [Specification]
4	SHIELD	-
5	V	-
6	L	-
7	L	-
10	P	-
11	SHIELD	-
12	R	-
13	SHIELD	-
14	R	-
15	L	-
16	R	-

Connector No.	E3
Connector Name	WIRE TO WIRE
Connector Type	TH24MW-AH



1	2	3	4	5	6	7	8	9	10	11	12
13	14	15	16	17	18	19	20	21	22	23	24

Terminal No.	Color Of Wire	Signal Name [Specification]
1	LG	- [With 2.0L turbo gasoline engine]
1	Y	- [With VR30 engine]
2	W	-
4	P	- [With VR30 engine]
4	SB	- [With 2.0L turbo gasoline engine]
5	L	-
6	Y	-
7	LG	-
8	BG	-
9	W	-
10	B	-
11	G	-
12	R	-
13	GR	-
14	G	-
15	LG	- [With 2.0L turbo gasoline engine]
15	V	- [With VR30 engine]
16	Y	-
17	P	-
18	BR	-
19	LG	- [With 2.0L turbo gasoline engine]
19	Y	- [With VR30 engine]
20	GR	-
21	R	- [With 2.0L turbo gasoline engine]
21	V	- [With VR30 engine]
22	L	-
23	P	-
24	B	- [With VR30 engine]
24	BR	- [With 2.0L turbo gasoline engine]

Connector No.	E14
Connector Name	WIRE TO WIRE
Connector Type	SAAL18MB-RS10-S1Z2



1	2	3	4	5	6	7	8	9	10	11	12
13	14	15	16	17	18	19	20	21	22	23	24
25	26	27	28	29	30	31	32	33	34	35	36

Terminal No.	Color Of Wire	Signal Name [Specification]
4	Y	-
5	L	-
6	B	-
7	BG	-
8	LG	-
9	R	-
11	GR	-
12	R	-
13	B	-
14	G	-
15	G	-
16	V	-
17	B	-
18	SB	-
22	SHIELD	-
23	P	-
24	L	-
25	V	-
26	B	-
27	B	-
28	B	-

Connector No.	E22
Connector Name	CHASSIS CONTROL MODULE
Connector Type	TH24FW-AH



3	4	5	6	7	8	10	11	12
19	18	17	16	15	14	13	12	11

Terminal No.	Color Of Wire	Signal Name [Specification]
3	P	CAN-L [With Gateway]
3	R	CAN-L [With Gateway]
4	L	CAN-H
5	V	DRIVE MODE SELECT SWITCH [UP] [With VR30 engine]
5	Y	DRIVE MODE SELECT SWITCH [DOWN] [With VR30 engine]
6	G	DRIVE MODE SELECT SW [DOWN] [With VR30 engine]
6	Y	DRIVE MODE SELECT SW [DOWN] [With VR30 engine]
7	W	CHASSIS COMMUNICATION-L
8	W	CHASSIS COMMUNICATION-L
10	BG	IGNITION POWER SUPPLY [With 2.0L turbo gasoline engine]
10	G	IGNITION POWER SUPPLY [With VR30 engine]
11	L	CHASSIS COMMUNICATION-H
12	B	GROUND [With VR30 engine]
12	B/W	GROUND [With 2.0L turbo gasoline engine]
19	BR	CHASSIS COMMUNICATION-H [With VR30 engine]
19	L	CHASSIS COMMUNICATION-H [With 2.0L turbo gasoline engine]
23	G	ESS RELAY [With VR30 engine]
23	R	ESS RELAY [With 2.0L turbo gasoline engine]

Connector No.	E25
Connector Name	WIRE TO WIRE
Connector Type	TH80FW-CS16-TM4



1	2	3	4	5	6	7	8	9	10	11	12
13	14	15	16	17	18	19	20	21	22	23	24

INTELLIGENT CRUISE CONTROL

[ICC]

< WIRING DIAGRAM >

INTELLIGENT CRUISE CONTROL (2.0L TURBO GASOLINE ENGINE)

Terminal No.	Color Of Wire	Signal Name [Specification]
1	BG	-
6	V	-
7	L	-
8	BG	- [With VR30 engine]
8	BR	- [With 2.0L turbo gasoline engine]
9	B	- [With 2.0L turbo gasoline engine]
9	GR	- [With VR30 engine]
10	BR	-
11	L	-
12	GR	- [With VR30 engine]
12	P	- [With 2.0L turbo gasoline engine]
13	SHIELD	- [With 2.0L turbo gasoline engine]
13	W	- [With VR30 engine]
14	B	-
15	GR	- [With 2.0L turbo gasoline engine]
15	SB	- [With VR30 engine]
16	BR	- [With 2.0L turbo gasoline engine]
16	Y	- [With VR30 engine]
17	BR	- [With 2.0L turbo gasoline engine]
17	GR	- [With VR30 engine]
18	G	- [With 2.0L turbo gasoline engine]
18	P	- [With VR30 engine]
19	Y	-
31	W	- [With 2.0L turbo gasoline engine]
31	Y	- [With VR30 engine]
32	G	- [With 2.0L turbo gasoline engine]
32	GR	- [With VR30 engine]
33	L	- [With 2.0L turbo gasoline engine]
33	P	- [With VR30 engine]
34	P	-
35	GR	-
36	R	-
37	L	- [With 2.0L turbo gasoline engine]
37	V	- [With VR30 engine]
38	L	- [With 2.0L turbo gasoline engine]
38	R	- [With VR30 engine]
39	BR	- [With 2.0L turbo gasoline engine]
39	Y	- [With VR30 engine]
40	SB	-
41	LG	-
45	L	- [With 2.0L turbo gasoline engine]
45	W	- [With VR30 engine]
46	B	- [With 2.0L turbo gasoline engine]
46	Y	- [With VR30 engine]
47	G	-
48	SHIELD	-
49	R	-
50	BR	- [With VR30 engine]

50	GR	- [With 2.0L turbo gasoline engine]
51	L	-
52	W	- [With VR30 engine]
54	P	- [With 2.0L turbo gasoline engine]
55	B	- [With 2.0L turbo gasoline engine]
55	W	- [With VR30 engine]
56	BG	- [With 2.0L turbo gasoline engine]
56	SB	- [With VR30 engine]
57	W	- [With 2.0L turbo gasoline engine]
57	RG	- [With VR30 engine]
58	B/W	-
59	W	-
61	R	-
64	Y	-
65	BR	-
67	LG	-
68	BG	-
69	L	-
70	R	-
71	LG	- [With 2.0L turbo gasoline engine]
71	LG	- [With VR30 engine]
72	L	- [With 2.0L turbo gasoline engine]
72	V	- [With VR30 engine]
73	G	- [With 2.0L turbo gasoline engine]
74	BR	- [With VR30 engine]
74	L	- [With 2.0L turbo gasoline engine]
75	R	- [With 2.0L turbo gasoline engine]
75	V	- [With VR30 engine]
76	G	-
77	Y	-
78	LG	- [With 2.0L turbo gasoline engine and with ADAS]
78	P	- [With VR30 engine]
78	V	- [With 2.0L turbo gasoline engine and without ADAS]
79	SB	-
80	B	- [With VR30 engine]
80	G	- [With 2.0L turbo gasoline engine]
81	V	-
82	V	-
83	BR	- [With 2.0L turbo gasoline engine]
83	R	- [With VR30 engine]
84	LG	-
86	BG	-
87	G	-
88	GR	-
89	LG	-
90	G	- [With VR30 engine]
90	GR	- [With 2.0L turbo gasoline engine]
91	G	-

92	W	-
93	BG	-
94	GR	- [With VR30 engine]
94	L	- [With 2.0L turbo gasoline engine]
95	R	-
96	W	-
97	LG	-
98	L	-
99	LG	- [With 2.0L turbo gasoline engine]
99	P	- [With VR30 engine]
100	SHIELD	-

Connector No.	Color Of Wire	Signal Name [Specification]
E55		
AS5		AS5 ACTUATOR AND REVERSE UNIT (CONTROL UNIT)
S4230FB-SJZ4-U		

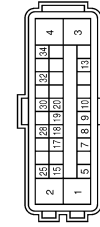

Terminal No.	Color Of Wire	Signal Name [Specification]
1	B	GROUND
2	B	GROUND
3	G	VALVE BATTERY [With VR30 engine]
3	P	VALVE BATTERY [With 2.0L turbo gasoline engine]
4	Y	MOTOR BATTERY
5	LG	STOP LAMP SW SIGNAL [With ADAS]
5	V	STOP LAMP SW SIGNAL [With ASCD]
7	GR	RR LH WHEEL SENSOR SIGNAL
8	G	RR RH WHEEL SENSOR POWER SUPPLY
9	BR	FR RH WHEEL SENSOR SIGNAL
10	GR	FR RH WHEEL SENSOR POWER SUPPLY
13	R	VACUUM SENSOR SIGNAL
15	P	CAN-L [Without Gateway]
15	R	CAN-L [With Gateway]
17	Y	RR RH WHEEL SENSOR SIGNAL
18	LG	RR RH WHEEL SENSOR POWER SUPPLY [With VR30 engine]
18	V	RR RH WHEEL SENSOR POWER SUPPLY [With VR30 engine]
19	SB	FR LH WHEEL SENSOR SIGNAL
20	BG	FR LH WHEEL SENSOR POWER SUPPLY
25	L	CAN-H
28	G	VACUUM SENSOR POWER SUPPLY
30	R	VDC OFF SW SIGNAL
32	SHIELD	VACUUM SENSOR GROUND

34	G	IGN
----	---	-----

Connector No.	Color Of Wire	Signal Name [Specification]
E44		
BRK PEDAL POSITION SWITCH		
S029L		



Terminal No.	Color Of Wire	Signal Name [Specification]
1	G	- [With 2.0L turbo gasoline engine]
1	V	- [With VR30 engine]
2	BG	-
2	BR	- [With 2.0L turbo gasoline engine]

Connector No.	Color Of Wire	Signal Name [Specification]
E52		
ICC BRAKE HOLD RELAY		
MS02FL-M2-LC		



Terminal No.	Color Of Wire	Signal Name [Specification]
1	V	-
2	G	-
3	V	-
5	BR	- [With 2.0L turbo gasoline engine]
5	L	- [With VR30 engine]

A
B
C
D
E
F
G
H
I
J
K
L
M
N
P

CCS

JROWC8976GB

INTELLIGENT CRUISE CONTROL

[ICC]

< WIRING DIAGRAM >

INTELLIGENT CRUISE CONTROL (2.0L TURBO GASOLINE ENGINE)

Connector No.	E57
Connector Name	STOP LAMP SWITCH
Connector Type	M04FW-LC



Terminal No.	Color Of Wire	Signal Name [Specification]
1	G	- [With ASCD]
1	L	- [With ADAS]
2	GR	- [With ASCD]
2	LG	- [With ADAS]
3	BR	-
4	V	-

Connector No.	E58
Connector Name	ESS RELAY
Connector Type	M503FB-M2-LC



Terminal No.	Color Of Wire	Signal Name [Specification]
1	P	- [With V830 engine]
1	R	- [With 2.0L turbo gasoline engine]
2	G	-
3	W	-
4	LG	-

Connector No.	E64
Connector Name	FUSE BLOCK (I/B)
Connector Type	N508FW-CS



Terminal No.	Color Of Wire	Signal Name [Specification]
1E	G	-
2E	P	-
3E	V	-
4E	GR	-
6E	L	-
7E	BG	-

Connector No.	E65
Connector Name	FUSE BLOCK (I/B)
Connector Type	TH12FW-NH

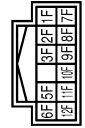

Terminal No.	Color Of Wire	Signal Name [Specification]
10F	W	-
11F	G	- [With 2.0L turbo gasoline engine]
11F	R	- [With V830 engine]
12F	W	- [With V830 engine]
12F	Y	- [With 2.0L turbo gasoline engine]
1F	R	-
2F	BR	-
3F	P	-
6F	L	-
7F	R	-
8F	L	-
9F	L	-

Connector No.	E76
Connector Name	WIRE TO WIRE
Connector Type	SA418FB-BS1D-S1Z2

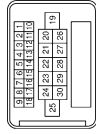

Terminal No.	Color Of Wire	Signal Name [Specification]
4	Y	-
5	L	-
6	B	-
7	BR	-
8	LG	-
9	GR	-
11	LG	-
12	BG	-
13	B	-
14	R	-
15	G	-
16	V	-
17	B	-
18	P	-
22	SHIELD	-
23	P	-
24	L	-
25	V	-
26	B	-
27	B	-
28	B	-

Connector No.	E80
Connector Name	ICC SENSOR
Connector Type	AAZ08FB

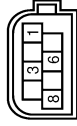

Terminal No.	Color Of Wire	Signal Name [Specification]
1	R	IGNITION POWER SUPPLY
3	L	ITS COMMUNICATION-H
6	Y	ITS COMMUNICATION-L
8	B	GROUND

Connector No.	E200
Connector Name	ECM
Connector Type	ADA52FB-AH26



Terminal No.	Color Of Wire	Signal Name [Specification]
97	G	POWER SUPPLY (MAIN)
98	R	ECM GROUND
99	G	POWER SUPPLY (MAIN)
100	B	ECM GROUND
101	G	POWER SUPPLY (MAIN)
103	B	ECM GROUND
103	V	COOLING FAN CONTROL SIGNAL (PWM)
104	Y	SENSOR POWER SUPPLY
105	R	SENSOR POWER SUPPLY
106	W	SENSOR GROUND
109	P	ENGINE SPEED SIGNAL
111	G	POWER SUPPLY
116	LG	STARTER RELAY-L
119	BR	SENSOR GROUND
120	BG	SENSOR GROUND
123	BR	MAIN RELAY CONTROL SIGNAL

INTELLIGENT CRUISE CONTROL

[ICC]

< WIRING DIAGRAM >

INTELLIGENT CRUISE CONTROL (2.0L TURBO GASOLINE ENGINE)

Terminal No.	Wire	Signal Name [Specification]
127	V	FUEL PUMP ON SIGNAL
132	G	ACCELERATOR PEDAL POSITION SENSOR 1
137	L	CAN-H
138	L	DRIVETRAIN CAN-H
142	GR	BACKLIP LAMP SWITCH
143	LG	REFRIGERANT PRESSURE SENSOR
145	L	ACCELERATOR PEDAL POSITION SENSOR 2
146	L	FUEL TANK PRESSURE SENSOR
148	L	THROTTLE CONTROL MOTOR (CLOSE) (BANK 2)
150	P	CAN-L
151	P	DRIVETRAIN CAN-L
152	B	EVAP CANISTER VENT CONTROL VALVE
153	G	EVAP PURGE CONTROL VALVE

Connector No.	E220
Connector Name	JOINT CONNECTOR E05
Connector Type	IN24FE-J



Terminal No.	Wire	Signal Name [Specification]
3	W	-
4	L	-
7	W	-
8	L	-
15	R	-
16	L	-
19	R	-
20	L	-
22	R	-
24	L	-

Connector No.	E223
Connector Name	JOINT CONNECTOR E06
Connector Type	SGA28FE-J



Terminal No.	Wire	Signal Name [Specification]
2	GR	-
3	G	-
4	BR	-
6	BG	-
7	G	-
8	BR	-
11	G	-
12	L	-
18	V	-
19	W	-
20	BG	-
22	GR	-
23	P	-
24	BR	-
26	V	-
27	W	-
28	BG	-

Connector No.	M13
Connector Name	BCM (BODY CONTROL MODULE)
Connector Type	TH40FG-NH



Terminal No.	Wire	Signal Name [Specification]
1	R	PUSH SW
3	Y	SENS PMW SPLY
4	BG	OPTICAL SENSOR

Terminal No.	Wire	Signal Name [Specification]
5	LG	AIR BAG SIG
10	W	COMBI SW OUTPUT 5
11	SB	COMBI SW OUTPUT 4
12	L	COMBI SW OUTPUT 3
13	G	COMBI SW OUTPUT 2
14	P	COMBI SW OUTPUT 1
15	G	ONE TOUCH LINK SENS (DR)
16	G	ONE TOUCH LINK SENS (PASS)
17	P	RECEIVER/SENSOR GND
18	L	SECURITY IND LAMP CONT
20	R	DEFINT SW
21	SB	STEP LAMP CONT
25	R	STOP LAMP SWZ
26	R	EXTENDED STORAGE FUSE SW
27	P	STOP LAMP SW
30	W	DR DOOR UNLK SENS
33	V	TR LID OP CANCEL SW
36	G	HAZARD SW
39	BR	P/A POSITION

Connector No.	M14
Connector Name	BCM (BODY CONTROL MODULE)
Connector Type	TH40FB-NH

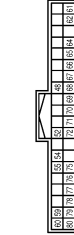

Terminal No.	Wire	Signal Name [Specification]
48	R	PUSH BTN IGN SW (ILL PWR)
52	G	DONGLE LINK
54	V	COMBI LINK
55	R	RAIN SENSOR
59	P	CANCEL
60	L	CAN-H
61	G	REAR WINDOW DEF RLY CONT
62	R	STARTER RLY CONT
64	V	HEY WARN BUZZER
65	B	OUTS HD LAMP CONT
66	B	BLOWER FAN RLY CONT (W/TH VR30 engine)
66	Y	BLOWER FAN RLY CONT (W/TH 2.0L turbo gasoline engine)
67	W/B	IGN RLYAY (F/B) CONT
68	R	DIMMER
69	GR	A/T SHIFT SELECT PMW SPLY

Terminal No.	Wire	Signal Name [Specification]
70	B	IGN RLYAY (PDM E/R) CONT
71	G	DR DOOR REQ SW
72	SB	PASS DOOR REQ SW
75	BR	COMBI SW INRUT 5
76	BG	COMBI SW INRUT 4
77	V	COMBI SW INRUT 3
78	Y	COMBI SW INRUT 2
79	LG	COMBI SW INRUT 1
80	L	TR LID OPNR SW

Connector No.	M18
Connector Name	WIRE TO WIRE
Connector Type	INS16MW-CS

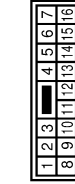

Terminal No.	Wire	Signal Name [Specification]
10	SB	-
11	Y	-
12	GR	-

Connector No.	M19
Connector Name	WIRE TO WIRE
Connector Type	TH80MW-CS16-1M4



Terminal No.	Wire	Signal Name [Specification]
1	Y	-
2	G	-
3	SB	-
5	Y	-
7	W	-
10	BG	-

A
B
C
D
E
F
G
H
I
J
K
L
M
N
P

CCS

JROWC8978GB

INTELLIGENT CRUISE CONTROL

[ICC]

< WIRING DIAGRAM >

INTELLIGENT CRUISE CONTROL (2.0L TURBO GASOLINE ENGINE)

11	BR	-	-	-	-
12	LG	-	-	-	-
13	GR	-	-	-	-
14	R	-	-	-	-
15	L	-	-	-	-
16	V	-	-	-	-
18	W	-	-	-	-
19	BR	-	-	-	-
20	W	-	-	-	-
24	R	-	-	-	-
24	Y	-	-	-	-
25	P	-	-	-	-
25	W	-	-	-	-
26	G	-	-	-	-
27	R	-	-	-	-
28	R	-	-	-	-
31	BR	-	-	-	-
32	B	-	-	-	-
33	B	-	-	-	-
34	V	-	-	-	-
35	P	-	-	-	-
36	W	-	-	-	-
37	SB	-	-	-	-
38	LG	-	-	-	-
40	P	-	-	-	-
41	G	-	-	-	-
42	BR	-	-	-	-
43	BR	-	-	-	-
44	BR	-	-	-	-
46	BG	-	-	-	-
50	W	-	-	-	-
51	Y	-	-	-	-
52	V	-	-	-	-
53	LG	-	-	-	-
54	R	-	-	-	-
55	R	-	-	-	-
58	V	-	-	-	-
59	BG	-	-	-	-
60	G	-	-	-	-
61	G	-	-	-	-
62	BG	-	-	-	-
63	BR	-	-	-	-
64	Y	-	-	-	-
66	R	-	-	-	-
70	LG	-	-	-	-
71	W	-	-	-	-
72	B	-	-	-	-
73	W	-	-	-	-
74	L	-	-	-	-
75	W	-	-	-	-

76	BR	-	-	-	-
77	B	-	-	-	-
78	SB	-	-	-	-
79	W	-	-	-	-
81	B	-	-	-	-
82	R	-	-	-	-
83	BG	-	-	-	-
84	L	-	-	-	-
85	W	-	-	-	-
86	B	-	-	-	-
88	G	-	-	-	-
89	V	-	-	-	-
91	GR	-	-	-	-
93	GR	-	-	-	-
94	W	-	-	-	-
96	W	-	-	-	-
98	BR	-	-	-	-
98	Y	-	-	-	-

Connector No.	M20
Connector Name	WIRE TO WIRE
Connector Type	TH16MV-NH



Terminal No.	Color Of Wire	Signal Name [Specification]
7	W	-
8	L	-
10	Y	-
11	SHIELD	-
12	B	-
13	W	-
14	R	-

Connector No.	M22
Connector Name	WIRE TO WIRE
Connector Type	TH80MW-C516-TM4

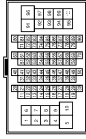

Terminal No.	Color Of Wire	Signal Name [Specification]
1	LG	-
2	L	-
2	SHIELD	-
3	BR	-
3	R	-
4	SHIELD	-
4	Y	-
5	G	-
5	V	-
6	BG	-
6	BR	-
7	LG	-
7	P	-
8	G	-
8	P	-
9	LG	-
9	SHIELD	-
10	V	-
11	GR	-
12	V	-
13	LG	-
14	LG	-
15	BR	-
15	P	-
16	SB	-
16	Y	-
17	Y	-
18	L	-
19	G	-
20	GR	-
21	R	-
23	L	-
24	BG	-
24	V	-
25	L	-
25	SB	-

26	G	-	-	-	-
26	W	-	-	-	-
27	R	-	-	-	-
28	R	-	-	-	-
29	LG	-	-	-	-
30	SB	-	-	-	-
30	W	-	-	-	-
31	SHIELD	-	-	-	-
32	L	-	-	-	-
33	B	-	-	-	-
34	LG	-	-	-	-
34	SHIELD	-	-	-	-
35	LG	-	-	-	-
35	W	-	-	-	-
36	R	-	-	-	-
37	R	-	-	-	-
37	V	-	-	-	-
38	L	-	-	-	-
38	L	-	-	-	-
39	W	-	-	-	-
39	P	-	-	-	-
39	R	-	-	-	-
39	V	-	-	-	-
40	G	-	-	-	-
41	L	-	-	-	-
42	R	-	-	-	-
43	SHIELD	-	-	-	-
44	P	-	-	-	-
45	B	-	-	-	-
45	G	-	-	-	-
46	SHIELD	-	-	-	-
47	G	-	-	-	-
48	BG	-	-	-	-
48	BR	-	-	-	-
48	SB	-	-	-	-
49	G	-	-	-	-
51	L	-	-	-	-
51	V	-	-	-	-
52	L	-	-	-	-
52	Y	-	-	-	-
53	B	-	-	-	-
54	GR	-	-	-	-
55	L	-	-	-	-
56	P	-	-	-	-
57	R	-	-	-	-
58	LG	-	-	-	-
59	SB	-	-	-	-
60	BR	-	-	-	-
61	L	-	-	-	-
61	R	-	-	-	-
62	P	-	-	-	-

INTELLIGENT CRUISE CONTROL

[ICC]

< WIRING DIAGRAM >

INTELLIGENT CRUISE CONTROL (2.0L TURBO GASOLINE ENGINE)

Terminal No.	Color Of Wire	Signal Name [Specification]	Notes
62	V	-	- [With VR30 engine]
63	L	-	- [With VR30 engine]
64	W	-	- [With VR30 engine]
65	R	-	- [With VR30 engine]
66	L	-	- [With VR30 engine]
67	G	-	- [With VR30 engine]
68	P	-	- [With VR30 engine]
69	L	-	- [With VR30 engine]
71	GR	-	- [With VR30 engine]
72	G	-	- [With VR30 engine]
73	LG	-	- [With VR30 engine]
73	SHIELD	-	- [With VR30 engine]
74	L	-	- [With VR30 engine]
74	LG	-	- [With VR30 engine]
75	P	-	- [With VR30 engine]
76	SB	-	- [With VR30 engine]
76	V	-	- [With VR30 engine]
77	Y	-	- [With VR30 engine]
78	L	-	- [With VR30 engine]
79	G	-	- [With VR30 engine]
80	GR	-	- [With VR30 engine]
80	W	-	- [With VR30 engine]
81	B	-	- [With VR30 engine]
81	R	-	- [With VR30 engine]
82	G	-	- [With VR30 engine]
82	SHIELD	-	- [With VR30 engine]
83	R	-	- [With VR30 engine]
83	W	-	- [With VR30 engine]
84	BR	-	- [With VR30 engine]
85	BR	-	- [With VR30 engine]
85	G	-	- [With VR30 engine]
86	R	-	- [With VR30 engine]
87	LG	-	- [With VR30 engine]
87	SHIELD	-	- [With VR30 engine]
88	R	-	- [With VR30 engine]
89	LG	-	- [With VR30 engine]
90	SB	-	- [With VR30 engine]
92	L	-	- [With VR30 engine]
92	W	-	- [With VR30 engine]
93	SHIELD	-	- [With VR30 engine]
94	R	-	- [With VR30 engine]
95	L	-	- [With VR30 engine]
95	Y	-	- [With VR30 engine]
96	W	-	- [With VR30 engine]
97	L	-	- [With VR30 engine]
97	L	-	- [With VR30 engine]
97	R	-	- [With VR30 engine]

Terminal No.	Color Of Wire	Signal Name [Specification]	Notes
99	BR	-	- [With VR30 engine and with BOSE system]
99	P	-	- [With 2.0L turbo gasoline engine]
99	Y	-	- [With VR30 engine and without BOSE system]
100	BR	-	- [With VR30 engine]
100	W	-	- [With 2.0L turbo gasoline engine]

Connector No.	Signal Name [Specification]
M24	CAN GATEWAY
TH12FM-NH	TH12FM-NH

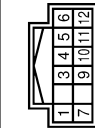

Terminal No.	Color Of Wire	Signal Name [Specification]	Notes
1	L	CAN-H (CAN COMMUNICATION CIRCUIT 1)	
3	W	BATTERY POWER SUPPLY	
4	L	CAN-H (CAN COMMUNICATION CIRCUIT 2)	
5	B	GROUND	
6	L	CAN-H (CAN COMMUNICATION CIRCUIT 2)	
7	P	CAN-L (CAN COMMUNICATION CIRCUIT 1)	
9	W	IGNITION POWER SUPPLY [With VR30 engine]	
9	W	IGNITION POWER SUPPLY [With 2.0L turbo gasoline engine]	
10	R	CAN-L (CAN COMMUNICATION CIRCUIT 2)	
11	B	GROUND	
12	R	CAN-L (CAN COMMUNICATION CIRCUIT 2)	

Connector No.	Signal Name [Specification]
M25	DATA LINK CONNECTOR
BD16FW	BD16FW

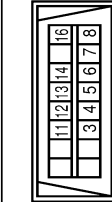

Terminal No.	Color Of Wire	Signal Name [Specification]	Notes
3	LG	M_CAN_L	
4	B	EARTH	
5	B	EARTH	
6	L	CAN-H	
7	V	KLINE [With 2.0L turbo gasoline engine]	
7	W	KLINE [With VR30 engine]	
8	W	IGL SW	
11	SB	M_CAN_H	
12	R	CAN-L	
13	L	CAN-H	
14	P	CAN-L	
16	W	POWER	

Connector No.	Signal Name [Specification]
M40	WIRE TO WIRE
TH80MW-C516-TM4	TH80MW-C516-TM4



Terminal No.	Color Of Wire	Signal Name [Specification]	Notes
1	BG	-	- [With VR30 engine]
6	W/B	-	- [With VR30 engine]
7	V	-	- [With VR30 engine]
8	BG	-	- [With VR30 engine]
8	BR	-	- [With 2.0L turbo gasoline engine]
9	LG	-	- [With VR30 engine]
9	P	-	- [With 2.0L turbo gasoline engine]
10	W	-	- [With VR30 engine]
11	W	-	- [With VR30 engine]
11	Y	-	- [With 2.0L turbo gasoline engine]
12	B	-	- [With VR30 engine]
12	BR	-	- [With 2.0L turbo gasoline engine]
13	GR	-	- [With VR30 engine]
13	SHIELD	-	- [With 2.0L turbo gasoline engine]
14	B	-	- [With VR30 engine]
15	BG	-	- [With 2.0L turbo gasoline engine]
15	SB	-	- [With VR30 engine]
16	B	-	- [With VR30 engine]
16	BR	-	- [With 2.0L turbo gasoline engine]
17	LG	-	- [With VR30 engine]

Terminal No.	Color Of Wire	Signal Name [Specification]	Notes
18	B	-	- [With VR30 engine]
18	W/B	-	- [With 2.0L turbo gasoline engine]
19	Y	-	- [With VR30 engine]
31	W	-	- [With VR30 engine]
32	G	-	- [With 2.0L turbo gasoline engine]
32	V	-	- [With VR30 engine]
33	L	-	- [With VR30 engine]
33	Y	-	- [With 2.0L turbo gasoline engine]
34	P	-	- [With VR30 engine]
35	BG	-	- [With VR30 engine]
36	G	-	- [With VR30 engine]
37	B	-	- [With 2.0L turbo gasoline engine]
38	L	-	- [With VR30 engine]
38	R	-	- [With 2.0L turbo gasoline engine]
39	R	-	- [With 2.0L turbo gasoline engine]
39	Y	-	- [With VR30 engine]
40	GR	-	- [With VR30 engine]
41	L	-	- [With VR30 engine]
45	L	-	- [With 2.0L turbo gasoline engine]
45	W	-	- [With VR30 engine]
46	G	-	- [With VR30 engine]
46	Y	-	- [With 2.0L turbo gasoline engine]
47	BG	-	- [With 2.0L turbo gasoline engine]
47	R	-	- [With VR30 engine]
48	SHIELD	-	- [With VR30 engine]
49	B	-	- [With VR30 engine]
49	G	-	- [With 2.0L turbo gasoline engine]
50	B	-	- [With 2.0L turbo gasoline engine]
50	BR	-	- [With VR30 engine]
51	L	-	- [With VR30 engine]
52	W	-	- [With VR30 engine]
54	SB	-	- [With 2.0L turbo gasoline engine]
54	Y	-	- [With VR30 engine]
55	B	-	- [With 2.0L turbo gasoline engine]
55	P	-	- [With VR30 engine]
56	BG	-	- [With VR30 engine]
56	GR	-	- [With 2.0L turbo gasoline engine]
57	GR	-	- [With VR30 engine]
57	P	-	- [With 2.0L turbo gasoline engine]
58	B	-	- [With VR30 engine]
59	SB	-	- [With VR30 engine]
61	W/B	-	- [With VR30 engine]
64	Y	-	- [With VR30 engine]
65	R	-	- [With VR30 engine]
67	LG	-	- [With VR30 engine]
68	BG	-	- [With VR30 engine]
69	L	-	- [With VR30 engine]
70	R	-	- [With VR30 engine]
71	V	-	- [With VR30 engine]

A
B
C
D
E
F
G
H
I
J
K
L
M
N
P



INTELLIGENT CRUISE CONTROL

[ICC]

< WIRING DIAGRAM >

INTELLIGENT CRUISE CONTROL (2.0L TURBO GASOLINE ENGINE)

71	W	- [With 2.0L turbo gasoline engine]
72	L	- [With 2.0L turbo gasoline engine]
73	LG	- [With VR30 engine]
74	R	- [With VR30 engine]
75	W	- [With 2.0L turbo gasoline engine]
76	BR	- [With VR30 engine]
77	B	- [With 2.0L turbo gasoline engine]
78	R	- [With VR30 engine]
79	G	- [With VR30 engine]
80	B	- [With 2.0L turbo gasoline engine]
81	G	- [With VR30 engine]
82	LG	- [With 2.0L turbo gasoline engine]
83	BR	- [With VR30 engine]
84	V	- [With 2.0L turbo gasoline engine]
85	V	- [With VR30 engine]
86	V	- [With 2.0L turbo gasoline engine]
87	G	- [With VR30 engine]
88	R	- [With 2.0L turbo gasoline engine]
89	V	- [With VR30 engine]
90	G	- [With 2.0L turbo gasoline engine]
91	W	- [With VR30 engine]
92	W	- [With 2.0L turbo gasoline engine]
93	BR	- [With VR30 engine]
94	GR	- [With VR30 engine]
95	BR	- [With 2.0L turbo gasoline engine]
96	W	- [With VR30 engine]
97	LG	- [With 2.0L turbo gasoline engine]
98	Y	- [With VR30 engine]
99	LG	- [With 2.0L turbo gasoline engine]
100	SHIELD	- [With 2.0L turbo gasoline engine]

Connector No.	M58
Connector Name	COMBINATION METER
Connector Type	TH12FW-AH



Terminal No.	Color Of Wire	Signal Name [Specification]
41	L	CAN-H
42	P	CAN-L
43	B	ILLUMINATION CONTROL SIGNAL
44	Y	FUEL LEVEL SENSOR GROUND
45	W	BATTERY POWER SUPPLY
46	BG	Ignition signal. [With 2.0L turbo gasoline engine models]
47	R	IGNITION SIGNAL [With VR30DDTT engine models]
48	LG	AV COMMUNICATION SIGNAL (H)
51	BR	AV COMMUNICATION SIGNAL (L)
52	B	FUEL LEVEL SENSOR SIGNAL GROUND

Connector No.	M77
Connector Name	STEERING ANGLE SENSOR
Connector Type	TH08FW-AH



Terminal No.	Color Of Wire	Signal Name [Specification]
1	B	GROUND
2	P	CAN-L [Without Gateway]
3	R	CAN-L [With Gateway]
4	G	IGN
5	L	CAN-H

Connector No.	M85
Connector Name	RESISTOR
Connector Type	MD2FBR-LC



Terminal No.	Color Of Wire	Signal Name [Specification]
1	LG	-
2	B	-

Connector No.	M107
Connector Name	DRIVER ASSISTANCE BUZZER
Connector Type	NS02FW-CS



Terminal No.	Color Of Wire	Signal Name [Specification]
1	R	-
2	G	-

Connector No.	M133
Connector Name	FUSE BLOCK (I/B)
Connector Type	TH40FW-AH



Terminal No.	Color Of Wire	Signal Name [Specification]
10C	V	-
12C	L	-
13C	L	-
14C	Y	-
15C	R	-
16C	R	-
17C	L	-
18C	BG	- [Without DRPO]
18C	P	- [With DRPO]
19C	B	-
1C	R	-
20C	W	-
21C	L	-
22C	L	-
23C	L	-
23C	LG	-
26C	SB	-
27C	P	-
28C	W	-
29C	W	-
2C	R	-
30C	R	-
31C	W	-
32C	R	-
33C	B	- [With VR30 engine]
33C	R	- [With 2.0L turbo gasoline engine]
34C	W/B	-
35C	SB	-
36C	R	-
37C	W	-
38C	SB	-
39C	V	-
3C	P	-
40C	G	-
4C	P	-
5C	P	-

JROWC8981GB

INTELLIGENT CRUISE CONTROL

[ICC]

< WIRING DIAGRAM >

INTELLIGENT CRUISE CONTROL (2.0L TURBO GASOLINE ENGINE)

6C	G	-	-
7C	G	-	-
8C	G	-	-
9C	V	-	-

Connector No.	M137
Connector Name	JOINT CONNECTOR-M10
Connector Type	24342_4G2A

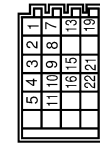

Connector No.	M147
Connector Name	EMCM
Connector Type	RH40FB-R28-4LH-Z



Connector No.	M173
Connector Name	JOINT CONNECTOR-M03
Connector Type	24342_4G2A



Connector No.	M174
Connector Name	JOINT CONNECTOR-M04
Connector Type	24342_4G2A



Terminal No.	Color	Wire	Signal Name [Specification]
1	Y	Y	EMCM RELAY CONTROL (SOPFF)
5	L	L	IGNITION SWITCH
6	LG	LG	STOP LAMP SWITCH
9	L	L	CAN-H
10	P	P	CAN-L
13	W	W	STOP/START OFF SWITCH
15	Y	Y	SENSOR POWER SUPPLY (FOR BATTERY CURRENT/TEMPERATURE SENSORS)
16	W	W	SENSOR GROUND (SUB BATTERY CURRENT/TEMPERATURE SENSORS)
21	V	V	SUB BATTERY RELAY CONTROL
22	G	G	ENGINE RESTART BYPASS CONTROL RELAY
23	BR	BR	BRAKE PEDAL POSITION SWITCH
24	GR	GR	MAIN BATTERY CURRENT SENSOR
25	BG	BG	MAIN BATTERY TEMPERATURE SENSOR
26	R	R	SUB BATTERY CURRENT SENSOR
27	BR	BR	SUB BATTERY TEMPERATURE SENSOR
35	SB	SB	SENSOR GROUND (MAIN BATTERY CURRENT/TEMPERATURE SENSORS)
36	G	G	SENSOR GROUND (SUB BATTERY CURRENT/TEMPERATURE SENSORS)
42	G	G	EMCM POWER SUPPLY
45	R	R	SUB BATTERY VOLTAGE MONITOR
47	B	B	EMCM GROUND
48	B	B	EMCM GROUND

Terminal No.	Color	Wire	Signal Name [Specification]
1	L	L	-
2	L	L	-
3	L	L	-
4	L	L	-
5	L	L	-
6	L	L	-
7	R	R	-
8	R	R	-
9	R	R	-
10	R	R	-
11	R	R	-
12	R	R	-
13	SB	SB	-
14	SB	SB	-
15	SB	SB	-
16	L	L	- [With 2.0L turbo gasoline engine]
16	SB	SB	- [With VR30 engine]
17	L	L	- [With 2.0L turbo gasoline engine]
17	SB	SB	- [With VR30 engine]
18	L	L	- [With 2.0L turbo gasoline engine]
18	SA	SA	- [With VR30 engine]
19	BR	BR	- [With VR30 engine]
19	LG	LG	- [With 2.0L turbo gasoline engine]
20	BR	BR	- [With VR30 engine]
20	LG	LG	- [With 2.0L turbo gasoline engine]
21	BR	BR	- [With VR30 engine]
21	LG	LG	- [With 2.0L turbo gasoline engine]
22	R	R	- [With 2.0L turbo gasoline engine]
22	SB	SB	- [With VR30 engine]
23	R	R	- [With 2.0L turbo gasoline engine]
23	SB	SB	- [With VR30 engine]
24	R	R	- [With 2.0L turbo gasoline engine]
24	SB	SB	- [With VR30 engine]

Terminal No.	Color	Wire	Signal Name [Specification]
3	L	L	-
4	L	L	-
5	L	L	-
6	L	L	-
9	Y	Y	-
10	Y	Y	-
11	Y	Y	-
12	Y	Y	-
13	SB	SB	-
14	SB	SB	-
15	SB	SB	-
16	SB	SB	-
17	SB	SB	-
18	SB	SB	-
19	LG	LG	-
20	LG	LG	-
21	LG	LG	-
22	LG	LG	-
23	LG	LG	-
24	LG	LG	-

A
B
C
D
E
F
G
H
I
J
K
L
M
N
P



JROWC8982GB

INTELLIGENT CRUISE CONTROL

[ICC]

< WIRING DIAGRAM >

INTELLIGENT CRUISE CONTROL (2.0L TURBO GASOLINE ENGINE)

Connector No.	M175
Connector Name	JOINT CONNECTOR-M05
Connector Type	NH20FL-DC

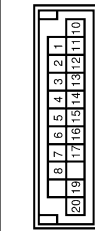

Terminal No.	Color Of Wire	Signal Name [Specification]
1	L	-
2	L	-
3	L	-
4	L	-
5	L	-
6	L	-
7	L	-
8	L	-
10	P	-
11	P	-
12	P	-
13	P	-
14	P	-
15	P	-
16	P	-
17	P	-
19	W	-
20	W	-

Connector No.	M177
Connector Name	JOINT CONNECTOR-M07
Connector Type	24342_4G52A

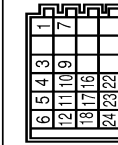

Terminal No.	Color Of Wire	Signal Name [Specification]
1	L	-
3	L	-
4	L	-
5	L	-
6	L	-
7	P	-
9	P	-
10	P	-
11	P	-
12	P	-
16	L	-
17	L	-
18	L	-
22	P	-
23	P	-
24	P	-



Connector No.	M183
Connector Name	JOINT CONNECTOR-M11
Connector Type	TK04FW-J

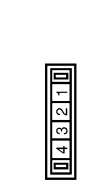

Connector No.	M184
Connector Name	JOINT CONNECTOR-M12
Connector Type	TK04FW-J



Terminal No.	Color Of Wire	Signal Name [Specification]
1	W	-
2	W	-
3	W	-
4	W	-

Connector No.	M190
Connector Name	COMBINATION SWITCH (SPIRAL CABLE)
Connector Type	TH24FW-NHY-GPA

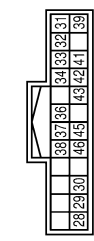

Connector No.	M302
Connector Name	COMBINATION SWITCH (SPIRAL CABLE)
Connector Type	SUMITOMOHTH-12



Terminal No.	Color Of Wire	Signal Name [Specification]
13	-	-
14	-	-
15	-	-
16	-	-
17	-	-
18	-	-
19	-	-
20	-	-
21	-	-
22	-	-
23	-	-
24	-	-

Terminal No.	Color Of Wire	Signal Name [Specification]
28	Y/R	-
29	Y	-
30	Y/B	-
31	SB	-
32	B	-
33	W/B	-
34	P	-
36	BG	-
37	G	-
38	R	-
39	Y	-
41	B	-
42	B	-
43	LG	-
45	L	-
46	R	-

DIAGNOSIS AND REPAIR WORK FLOW

< BASIC INSPECTION >

[ICC]

BASIC INSPECTION

DIAGNOSIS AND REPAIR WORK FLOW

Work Flow

INFOID:000000013711811

OVERALL SEQUENCE

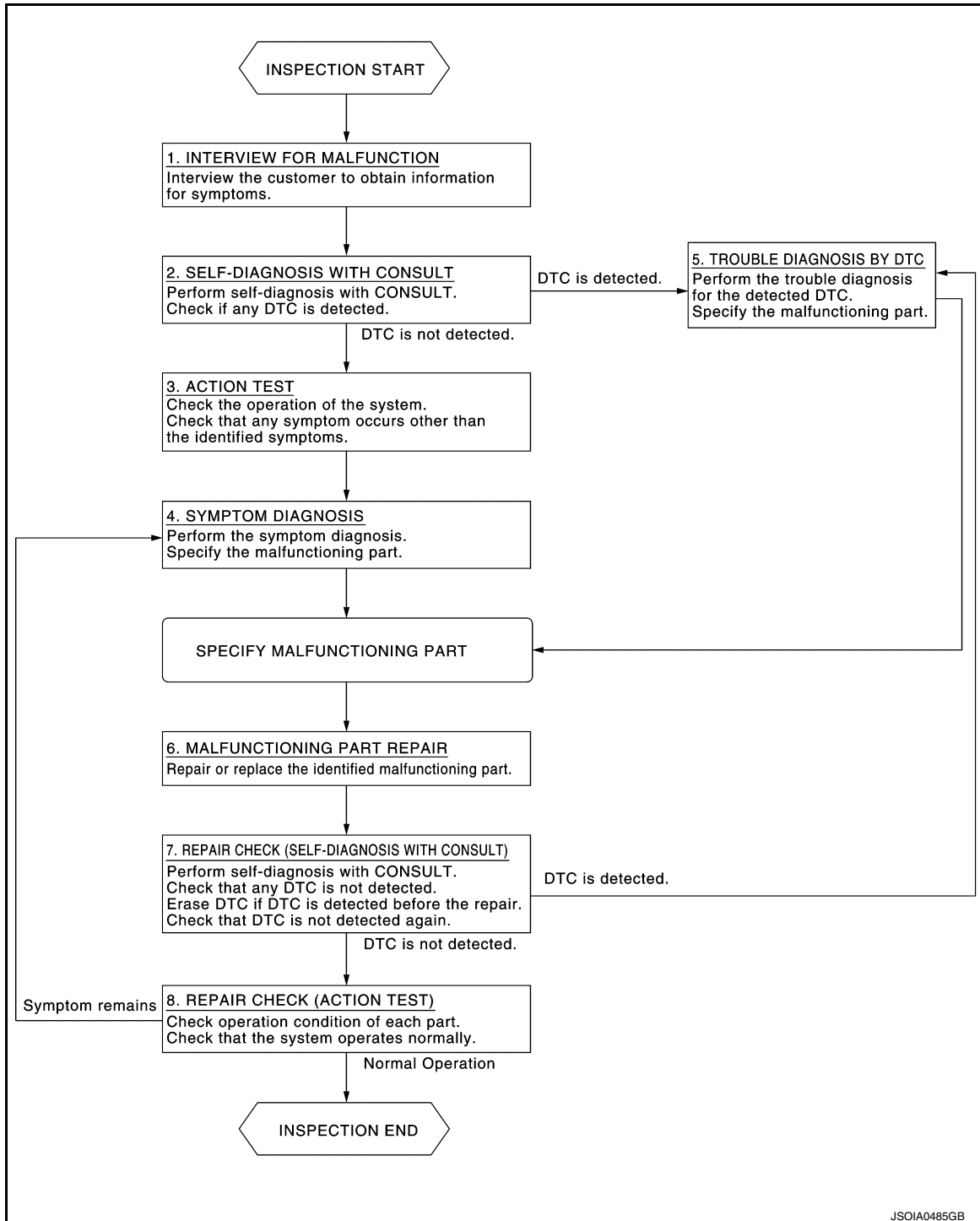

DETAILED FLOW

1. INTERVIEW FOR MALFUNCTION

It is also important to clarify the customer concerns before starting the inspection. Interview the customer about the concerns carefully and understand the symptoms fully.

NOTE:

A
B
C
D
E
F
G
H
I
J
K
L
M
N
P

CCS

DIAGNOSIS AND REPAIR WORK FLOW

[ICC]

< BASIC INSPECTION >

The customers are not professionals. Never assume that “maybe the customer means…” or “maybe the customer mentioned this symptom”.

>> GO TO 2.

2. SELF-DIAGNOSIS WITH CONSULT

1. Perform “All DTC Reading” with CONSULT.
2. Check if any DTC is detected in self-diagnosis results of “ICC/ADAS”, “LASER/RADAR”, and “ICC/ADAS 2”.

Is any DTC detected?

YES >> GO TO 5.

NO >> GO TO 3.

3. ACTION TEST

Perform the ICC system action test to check the operation status. Refer to [CCS-144, "Description"](#).
Check if any other malfunctions occur.

>> GO TO 4.

4. SYMPTOM DIAGNOSIS

Perform the applicable diagnosis according to the diagnosis chart by symptom. Refer to [CCS-174, "Symptom Table"](#).

>> GO TO 6.

5. TROUBLE DIAGNOSIS BY DTC

1. Check the DTC in the self-diagnosis results.
2. Perform trouble diagnosis for the detected DTC. Refer to [DAS-67, "DTC Index"](#) (ICC/ADAS) or [CCS-88, "DTC Index"](#) (LASER/RADAR) or [DAS-77, "DTC Index"](#) (ICC/ADAS 2).

NOTE:

If “DTC: U1000” is detected, first diagnose the CAN communication system or ITS communication system.

>> GO TO 6.

6. MALFUNCTIONING PART REPAIR

Repair or replace the identified malfunctioning parts.

>> GO TO 7.

7. REPAIR CHECK (SELF-DIAGNOSIS WITH CONSULT)

1. Erases self-diagnosis results.
2. Perform “All DTC Reading” again after repairing or replacing the malfunctioning parts.
3. Check if any DTC is detected in self-diagnosis results of “ICC/ADAS”, “LASER/RADAR”, and “ICC/ADAS 2”.

Is any DTC detected?

YES >> GO TO 5.

NO >> GO TO 8.

8. REPAIR CHECK (ACTION TEST)

Perform the ICC system action test. Check if the malfunction symptom is solved or no other symptoms occur.

Is there any malfunction symptom?

YES >> GO TO 4.

NO >> INSPECTION END

ADDITIONAL SERVICE WHEN REPLACING ICC SENSOR

< BASIC INSPECTION >

[ICC]

ADDITIONAL SERVICE WHEN REPLACING ICC SENSOR

Description

INFOID:0000000013711812

- Always perform the radar alignment after removing and installing or replacing the ICC sensor.

CAUTION:

- **The system does not operate normally unless the radar alignment is performed. Always perform it.**
- Perform the ICC system action test to check that the ICC system operates normally.

Work Procedure

INFOID:0000000013711813

1. PERFORM RADAR ALIGNMENT

Perform the radar alignment. Refer to [CCS-132, "Application Notice"](#).

>> GO TO 2.

2. ICC SYSTEM ACTION TEST

1. Perform the ICC system action test. Refer to [CCS-144, "Description"](#).
2. Check that the ICC system operates normally.

>> INSPECTION END

A
B
C
D
E
F
G
H
I
J
K
L
M
N
P

CCS

ICC SENSOR ALIGNMENT

Application Notice

INFOID:000000013711814

Type	Description
TYPE 1	When using KV99112700 for radar alignment. Refer to CCS-132, "TYPE 1 : Description" .
TYPE 2	When using following tools for radar alignment. Refer to CCS-136, "TYPE 2 : Description" . <ul style="list-style-type: none"> • ICC Alignment Kit (1-20-2721-1-IF) • Wheel Adaptor (1-20-2722-1-IF) • ICC alignment kit attachment board (J-50808)

TYPE 1

TYPE 1 : Description

INFOID:000000013711815

OUTLINE OF RADAR ALIGNMENT PROCEDURE

- A 4-wheel vehicle alignment must be performed before proceeding with radar alignment procedure.
- Always perform the radar alignment after removing and installing or replacing the ICC sensor.

WARNING:

Radio waves could adversely affect electric medical equipment. Those who use a pacemaker should contact the electric medical equipment manufacturer for the possible influences before use.

CAUTION:

The system does not operate normally unless the radar alignment is performed. Always perform it.

1. Set the distance sensor target board (SST: KV99112700) to the correct position in front of the vehicle.
2. Set the radar alignment mode ("MILLIWAVE RADAR ADJUST" on "Work support") with CONSULT, and then perform the adjustment according to the display. (ICC sensor automatically adjusts.)

CAUTIONARY POINT FOR RADAR ALIGNMENT PROCEDURE

CAUTION:

- For radar alignment procedure, choose a level location with a few meter of working space in front and surrounding the vehicle.
- Vehicle must be stationary and unoccupied during the whole alignment procedure.
- Any slight vibration during the alignment procedure can cause the test to fail. If this happens, you will have to restart the alignment process.
- The ignition switch must be in the ON position.
- The battery voltage must not fall below 12 volts during the whole alignment procedure. Failure to maintain adequate battery voltage will cause the test to fail. If this happens, you will have to restart the alignment process.
- The ICC target board must be set in front of the vehicle facing the sensor.
- Adjust the radar alignment with CONSULT. (The radar alignment procedure cannot be adjusted without CONSULT.)
- Never enter the vehicle during radar alignment.
- Never block the area between the radar and the ICC target board at any time during the alignment process.
- Accurate steering wheel setting is crucial. Once set, do not disturb the steering wheel for the remainder of the alignment procedure.
- For proper system operation and adjustment, all vehicle wheels must be of the same size.

TYPE 1 : Work Procedure (Preparation)

INFOID:000000013711816

1. ADVANCE PREPARATION FOR RADAR ALIGNMENT

1. Adjust all tire pressure to the specified value.
2. Empty the vehicle. (Remove any luggage from the passenger compartment, trunk room, etc.)
3. Shift the selector lever to "P" position, and release the parking brake.
4. Fully fill the fuel tank, and then check that the coolant and oils are filled up to correct level.

ICC SENSOR ALIGNMENT

< BASIC INSPECTION >

[ICC]

5. Clean the ICC sensor area ① of the front bumper grille.

>> GO TO 2.

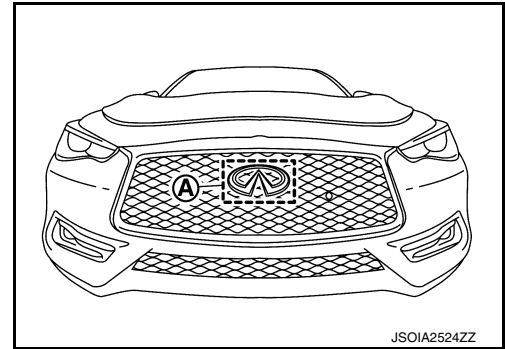

2. RADAR ALIGNMENT OPERATION AREA

Position the vehicle in a place that is level and where ① area can be secured.

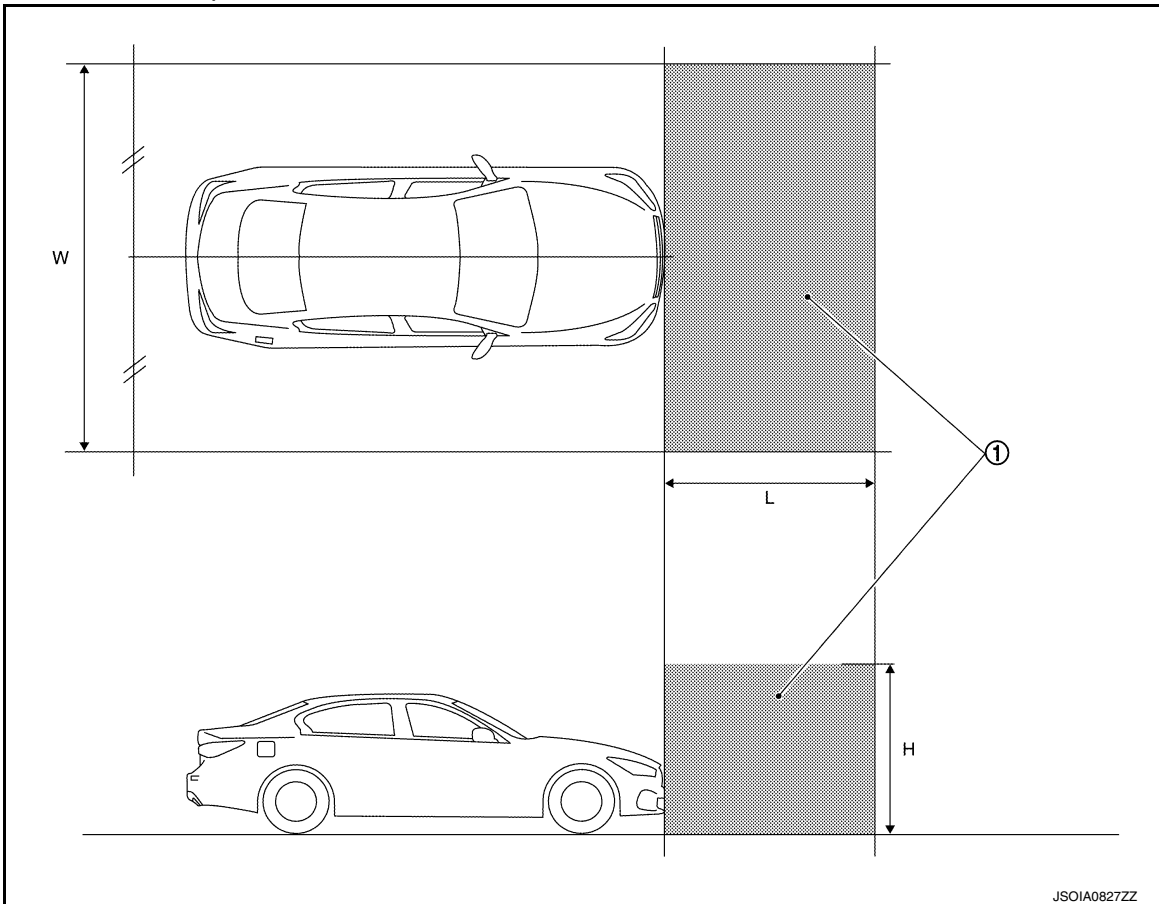

W : 3000 mm (118.11 in)

L : 2000 mm (78.74 in)

H : 2000 mm (78.74 in)

NOTE:

① is a no object zone.

>> Go to [CCS-133. "TYPE 1 : Work Procedure \(Setting The ICC Target Board\)".](#)

TYPE 1 : Work Procedure (Setting The ICC Target Board)

INFOID:000000013711817

DESCRIPTION

Accurate adjustment of the radar alignment requires that the ICC sensor target board be accurately positioned.

CAUTION:

A
B
C
D
E
F
G
H
I
J
K
L
M
N
P

CCS

ICC SENSOR ALIGNMENT

< BASIC INSPECTION >

[ICC]

If the radar alignment is adjusted with the distance sensor target board in the incorrect position, the ICC system does not function normally.

1. DISTANCE SENSOR TARGET BOARD HEIGHT ADJUSTMENT

Adjust the base of ICC target board to approximately 30 mm (1.18 in) from the ground.

>> GO TO 2.

2. PREPARATION OF SETTING DISTANCE SENSOR TARGET BOARD (1)

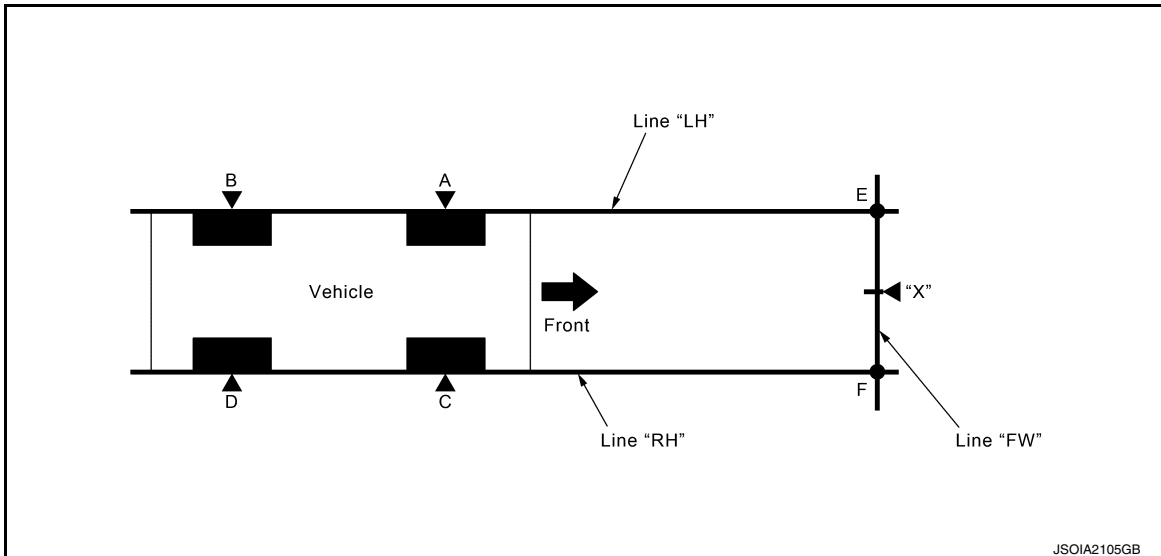

“A” – “E” (“C” – “F”) : 1747 mm (68.78 in)

1. Mark points “A”, “B”, “C” and “D” at the center of the lateral surface of each wheels.

NOTE:

Hang a string with a cone from the fender so as to pass through the center of wheel, and then mark a point at the center of the lateral surface of the wheel.

2. Draw line “LH” passing through points “A” and “B” on the left side of vehicle.

NOTE:

Approximately 2 m (6.56 ft) or more from the front end of vehicle.

3. Mark point “E” on the line “LH” at the positions 1747 mm (68.78 in) from point “A”.
4. Draw line “RH” passing through points “C” and “D” on the right side of vehicle in the same way as step 2.

NOTE:

Approximately 2 m (6.56 ft) or more from the front end of vehicle.

5. Mark point “F” on the line “RH” at the positions 1747 mm (68.78 in) from point “C”.
6. Draw line “FW” passing through the points “E” and “F” on the front side of vehicle.
7. Mark point “X” at the center of point “E” and “F” on the line “FW”.

CAUTION:

Make sure that “E” to “X” is equal to “F” to “X”.

>> GO TO 3.

3. SETTING DISTANCE SENSOR TARGET BOARD

Place the center of ICC target board on point “G” at line “E-F” and install the ICC target board.

CAUTION:

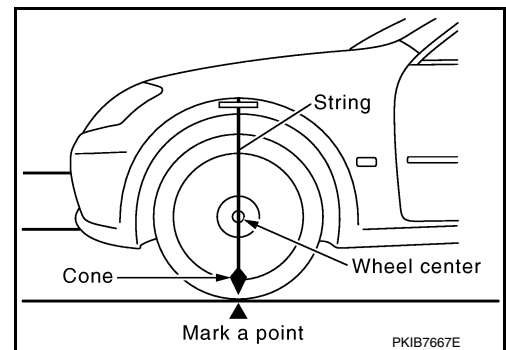

ICC SENSOR ALIGNMENT

< BASIC INSPECTION >

[ICC]

For performing the radar alignment correctly, securely install (ICC target board) to be parallel with the "E-F" line.

L1 : 1747 mm (68.78 in)

L2 : 0 mm (0.00 in)

>> GO TO 4.

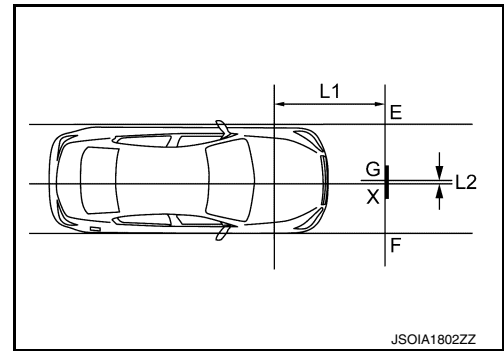

4. CHECK THE DISTANCE SENSOR TARGET BOARD INSTALLATION AREA

Do not place anything other than distance sensor target board in the space shown in the figure (view from top).

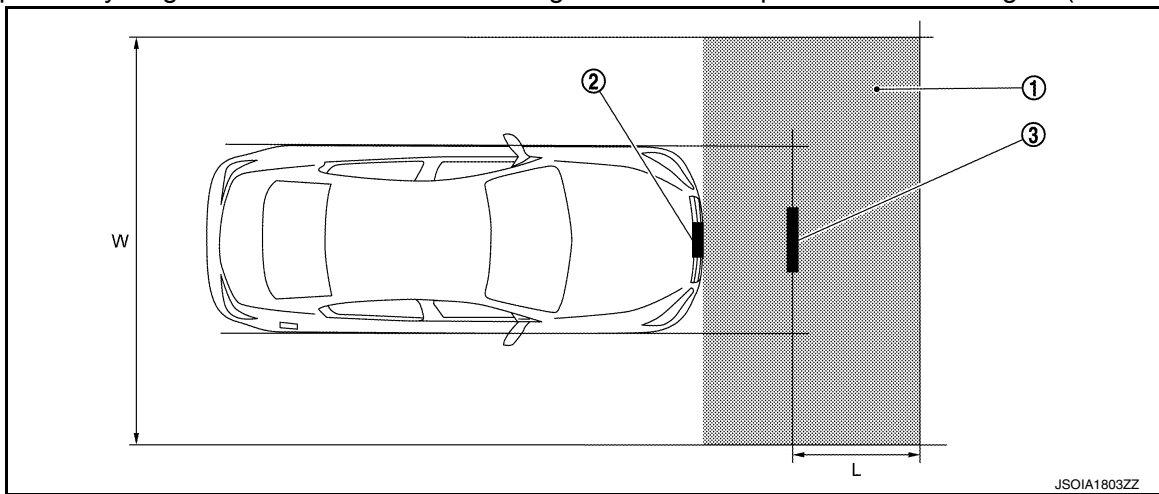

① No object zone

W. 3000 mm (118.11 in)

② ICC sensor

L. 1500 mm (59.06 in)

③ ICC target board

>> Go to [CCS-135, "TYPE 1 : Work Procedure \(Radar Alignment\)"](#).

TYPE 1 : Work Procedure (Radar Alignment)

INFOID:0000000013711818

DESCRIPTION

The radar alignment is performed automatically with CONSULT.

CAUTION:

Perform all necessary work for radar alignment until the adjustment completes as shown in the procedure. If the procedure does not complete, the ICC system is inoperable.

1. PERFORM RADAR ALIGNMENT

1. Start the engine.
2. Connect CONSULT and select "Work support" of "LASER/RADAR".
3. Select "MILLIWAVE RADAR ADJUST" after the "Work support" screen is displayed.

NOTE:

Confirm the following items;

- The target should be accurately placed.
- The vehicle should be stopped.

4. Select "Start" after the "MILLIWAVE RADAR ADJUST" screen is displayed.

CAUTION:

Never select "Start" when the target is not accurately placed.

5. Select "Start" after the preparation information is displayed.
6. Select "Next" after the "Starting alignment." screen is displayed.

NOTE:

A
B
C
D
E
F
G
H
I
J
K
L
M
N
P

CCS

ICC SENSOR ALIGNMENT

< BASIC INSPECTION >

[ICC]

If the radar is in alignment at this time, "Alignment in progress" is displayed. It may take several 10s of seconds until the result is displayed.

7. Confirm the displayed item.
 - "Alignment completed.": Go to 8.
 - Except "Alignment completed.": Perform the following services.

Displayed item	Possible cause	Service procedure
Alignment condition is not ready.	<ul style="list-style-type: none"> • DTC is detected (Except C1A12). • The position of the ICC target board is not correct. • Vehicle is moving. 	Check the vehicle condition and perform radar alignment again.
Alignment condition is not ready. (Stop the vehicle.)	Vehicle is moving.	Stop the vehicle and perform radar alignment again.
Target is not detected.	<ul style="list-style-type: none"> • A target is not-yet-placed. (The ICC sensor cannot detect target) • The position of the ICC target board is not correct. • The position of the ICC sensor is not correct. 	Check the target board condition and perform radar alignment again.
Sensor malfunction.	ICC sensor malfunction.	Check the vehicle condition and perform radar alignment again.

NOTE:

Replace ICC sensor if "Sensor malfunction." is repeatedly indicated.

8. Confirm displayed value.

Displayed item	Monitor item	Reference value
Alignment completed.	FACTORY AIM L/R	Less than ± 2.00 deg
	FACTORY AIM U/D	Less than ± 2.00 deg
	AIMING VALUE L/R	Less than ± 2.00 deg
	AIMING VALUE U/D	Less than ± 2.00 deg

- Within reference value: Go to 9.
- Outside of reference value: Check the target board condition and perform radar alignment again.

NOTE:

- Check the condition of the ICC sensor installation.
- Check the vehicle for damage.
- Replace ICC sensor if it is outside the reference value, even when ICC sensor installation is installed normally and the vehicle is not damaged.

9. Select "OK" after the "No error detected." is displayed.
10. Select "OK" after the "End of alignment." is displayed.

CAUTION:

Once "MILLIWAVE RADAR ADJUST" is started with CONSULT, always continue the work until the horizontal radar alignment is completed successfully. If the job is stopped midway, the radar alignment is not adjusted and the ICC system cannot operate.

>> RADAR ALIGNMENT END

TYPE 2

TYPE 2 : Description

INFOID:000000013711819

OUTLINE OF RADAR ALIGNMENT PROCEDURE

- A 4-wheel vehicle alignment must be performed before proceeding with radar alignment procedure.
- Always perform the radar alignment after removing and installing or replacing the ICC sensor.
- Always perform the radar alignment if rear axle toe settings have been made.

WARNING:

Radio waves could adversely affect electric medical equipment. Those who use a pacemaker should contact the electric medical equipment manufacturer for the possible influences before use.

CAUTION:

The system does not operate normally unless the ICC sensor is aligned properly.

ICC SENSOR ALIGNMENT

[ICC]

< BASIC INSPECTION >

1. Required tools, refer to [CCS-137, "TYPE 2 : Required Tools"](#).
2. Preparation, refer to [CCS-138, "TYPE 2 : Preparation"](#).
3. Vehicle set up, refer to [CCS-138, "TYPE 2 : Vehicle Set Up"](#).
4. Setting the ICC target board, refer to [CCS-141, "TYPE 2 : Setting The ICC Target Board"](#).
5. ICC sensor adjustment, refer to [CCS-142, "TYPE 2 : ICC Sensor Adjustment"](#).

CAUTIONARY POINT FOR RADAR ALIGNMENT PROCEDURE

CAUTION:

- For radar alignment procedure, choose a level location with a few feet of working space in front and surrounding the vehicle.
- Vehicle must be stationary and unoccupied during the whole alignment procedure.
- Any slight vibration during the alignment procedure can cause the test to fail. If this happens, you will have to restart the alignment process.
- The battery voltage must not fall below 12 volts during the whole alignment procedure. Failure to maintain adequate battery voltage will cause the test to fail. If this happens, you will have to restart the alignment process.
- The ICC target board must be set in front of the vehicle facing the sensor.
- Adjust the radar alignment with CONSULT. (The radar alignment procedure cannot be adjusted without CONSULT.)
- Never enter the vehicle during radar alignment.
- Never block the area between the radar and the ICC target board at any time during the alignment process.
- Accurate steering wheel setting is crucial. Once set, do not disturb the steering wheel for the remainder of the alignment procedure.
- For proper system operation and adjustment, all vehicle wheels must be of the same size.

TYPE 2 : Required Tools

INFOID:0000000013711820

- ICC alignment kit in addition to one of the following:
 - a) Hunter self-centering wheel adapter (Hunter wheel alignment tool)
 - b) Special Service Tool kit 1-20-2722-1-IF (kit SCA W/Tire Clamp-ICC Aiming)

The following ICC alignment kit are necessary to perform the ICC sensor alignment:

- ICC target board.
 - ①: Position 1, with top tilted 2° toward vehicle (Not used).
 - ②: Position 2, vertical.
 - ③: Position 3, with top tilted 2° away from vehicle (Not used).

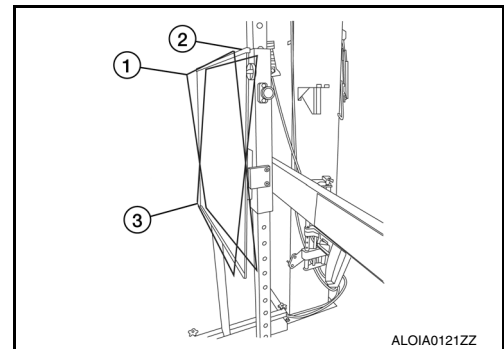

- Hunter self-centering wheel adapter ① [shown with laser assembly ② installed] (Hunter alignment rack head may be substituted).

NOTE:

- Retailers that are not equipped with a Hunter self-centering wheel adapter will require the following kit:
Part No. 1-20-2722-1-IF (kit SCA W/Tire Clamp-ICC Aiming)
- Directional arrows ① and ② are shown to illustrate the direction of the laser assembly beams.

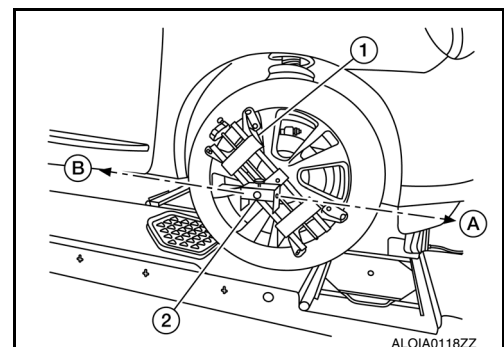

ICC SENSOR ALIGNMENT

[ICC]

< BASIC INSPECTION >

- Laser assembly (with bi-directional laser beam) as shown in the illustration.
 - Tightening knob ①
 - Power ON/OFF button ②
 - Front laser beam opening ③
 - Rear laser beam opening ④
 - Attaching shaft ⑤

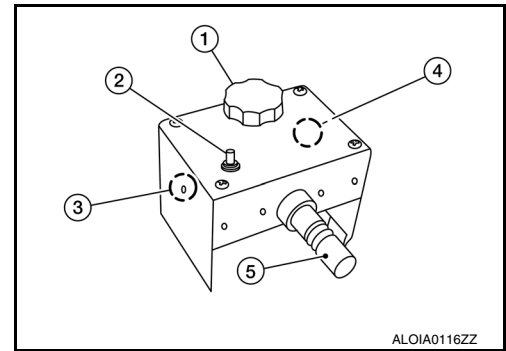

- Stationary target as shown in the illustration.
 - Stationary target ①
 - Laser signal reception plate ②

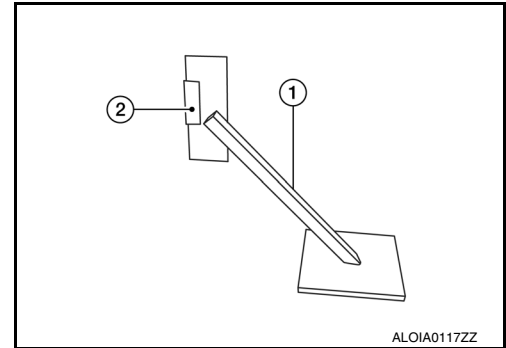

- ICC alignment kit attachment board as shown in the illustration.

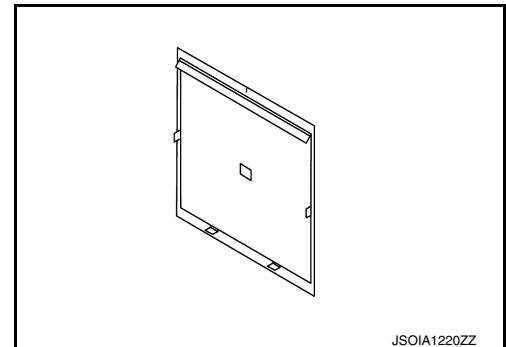

TYPE 2 : Preparation

INFOID:000000013711821

1. ADVANCE PREPARATION FOR RADAR ALIGNMENT PROCEDURE

1. Adjust all tire pressure to the specified value.
2. Empty the vehicle. (Remove any luggage from the passenger compartment, luggage room, etc.)
3. Shift the selector lever to "P" position, and release the parking brake.
4. Fully fill the fuel tank, and then check that the coolant and oils are filled up to correct level.
5. Clean the ICC sensor area ① of the front bumper grille.

>> Refer to [CCS-138. "TYPE 2 : Vehicle Set Up"](#).

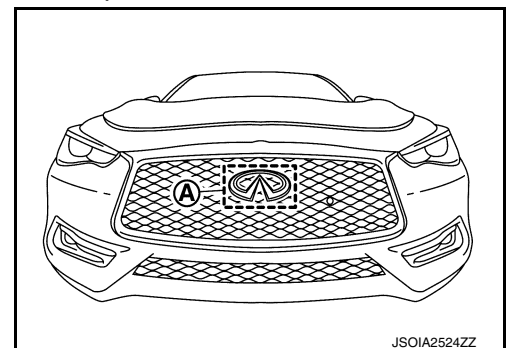

TYPE 2 : Vehicle Set Up

INFOID:000000013711822

DESCRIPTION

ICC SENSOR ALIGNMENT

[ICC]

< BASIC INSPECTION >

Accurate adjustment of the radar alignment requires that the ICC target board, wheel adapter, laser assembly, and stationary target be properly positioned.

CAUTION:

If the radar alignment is adjusted with the ICC target board, wheel adapter, laser assembly, or stationary target in the incorrect position, the ICC system will not function properly or the alignment procedure may not be completed successfully.

1. PREPOSITION TARGET BOARD

NOTE:

- To identify the sensor wave axis center, measure the point ① as shown in the illustration.

- A : 0 mm (0.00 in)**
- B : 573 mm (22.56 in)**
- C : Vehicle center**

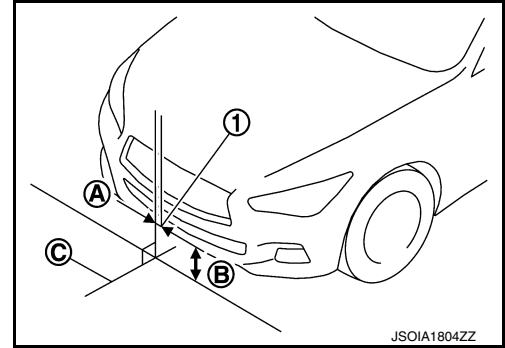

- ICC target board setting must be in the center position. (Position 2)
- Attaching the ICC alignment kit attachment board to the ICC target board.

- Position the ICC target board in front facing the right front side of the vehicle:
 - Place the marked center of the ICC target board ① 1060 mm (41.73 in.) \pm 50 mm (1.97 in) facing the ICC sensor.
 - Adjust the height of the ICC target board using the adjustable nut ② to achieve the proper height. The up/down tolerance is \pm 30 mm (1.18 in).
 - Adjust the ICC target board lateral position aligning the marked center of the board horizontally with the center of the ICC sensor. The right/left tolerance is \pm 80 mm (3.15 in).
- Extend the machined arm of the ICC target board exposing the reflective surface ③ to the right front side of the vehicle.
- Place one side of the laser assembly ② flush against the center of the ICC target board ① to assist in the positioning.

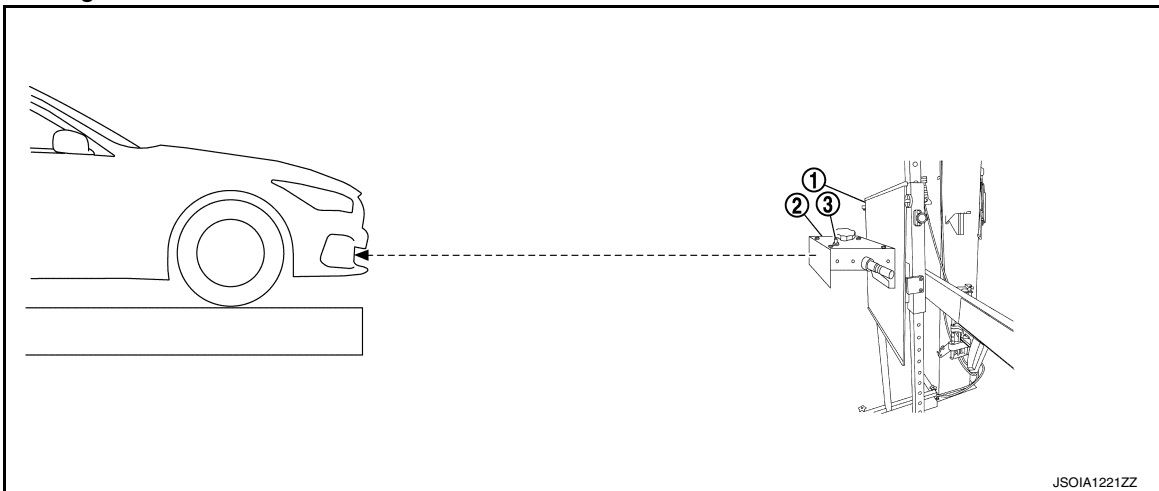
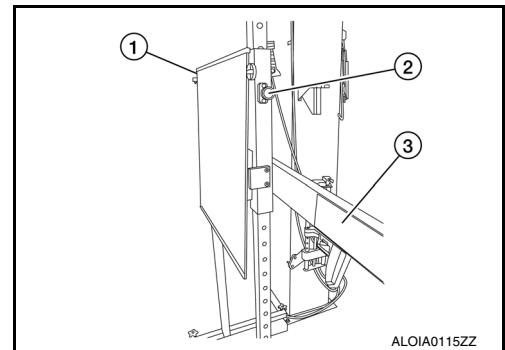

- Turn the laser assembly ON ③ allowing the laser beam to emit through the opening of the laser assembly toward the center of the ICC sensor.
- Move the ICC target board ① as necessary so that center of ICC target board aligns with center of ICC sensor.

A
B
C
D
E
F
G
H
I
J
K
L
M
N
P

CCS

ICC SENSOR ALIGNMENT

[ICC]

< BASIC INSPECTION >

6. Turn the laser assembly OFF when done.

Are using Hunter alignment equipment?

YES >> Refer to Hunter's equipment instructions for complete vehicle set up and ICC target board setting. Then, refer to [CCS-142. "TYPE 2 : ICC Sensor Adjustment"](#).

NO >> GO TO 2.

2. INSTALLING LASER ASSEMBLY

NOTE:

- Insure the steering wheel is positioned in the center straight forward position.
- Insure all 4 vehicle wheels do not contain any physical damage.

1. Install the wheel adapter ① on the right front wheel.
2. Mount the laser assembly ② to the wheel adapter ① as shown in the figure.

NOTE:

When the power switch is turned ON, the front laser signal ① will be emitted toward the front ICC target board, and the rear laser signal ② will be emitted toward the rear of the vehicle.

>> GO TO 3.

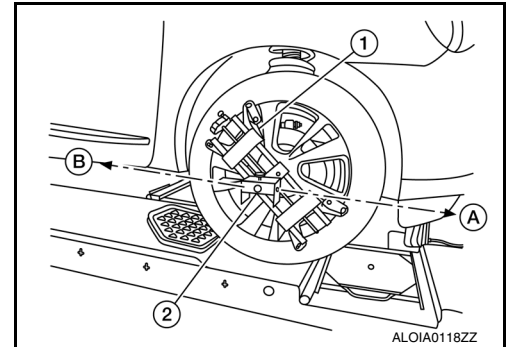

3. SETTING UP STATIONARY TARGET

1. Place the stationary target next to the right rear tire as shown in the figure.

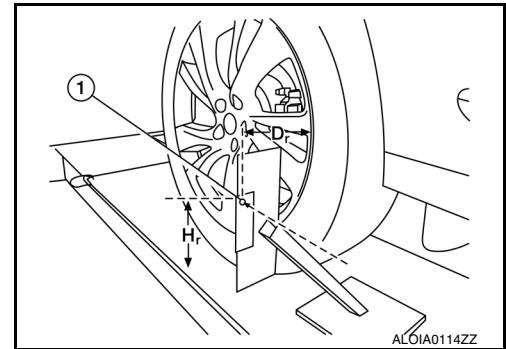

2. Turn the laser assembly ON allowing the laser beam to be emitted through the front and rear laser assembly openings.
3. Measure and record the distance (D_r) between the edge of the right rear wheel and the laser beam ① on the stationary target (horizontal line).
4. Measure and record the height (H_r) between the laser beam ① on the stationary target and ground level (vertical line).
5. Measure and record the distance (D_f) between the edge of the right front wheel and the laser beam signal/opening ① on the laser assembly (horizontal line).
6. Measure and record the height (H_f) between the laser beam signal/opening ① on the laser assembly and ground level (vertical line).

NOTE:

- Horizontal adjustment [front distance (D_f) and rear distance (D_r)] is accomplished by slowly turning the steering wheel until the 2 distances are the same.
- Vertical adjustment [front height (H_f) and rear height (H_r)] is accomplished by rotating the laser assembly around its axis until the two heights are the same.

7. Adjust laser beam as necessary until the two distances match and the two heights match.

NOTE:

Must be verify both horizontal and vertical adjustments anytime one adjustment is made.

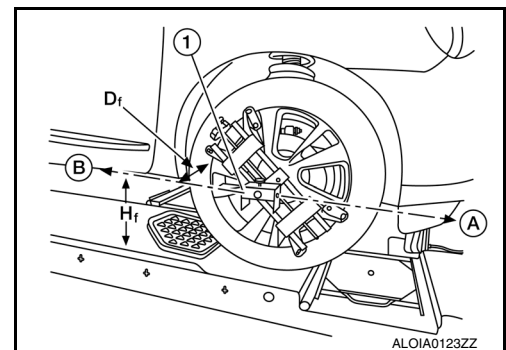

>> Refer to [CCS-141, "TYPE 2 : Setting The ICC Target Board"](#).

TYPE 2 : Setting The ICC Target Board

INFOID:000000013711823

DESCRIPTION

Accurate adjustment of the radar alignment requires that the ICC target board be accurately positioned.

CAUTION:

If the radar alignment is adjusted with the ICC target board in the incorrect position, the ICC system will not function properly or the alignment procedure may not be completed successfully.

1. ICC TARGET BOARD FINAL SETTING

1. With the ICC target board arm extended, the laser beam ① emitted by the laser assembly (A) will be reflected back (B) toward the laser assembly.

NOTE:

When adjusted properly, reflected laser beam (B) must align with emitted laser beam (A) and the two laser beams will be seen as one.

2. Rotate the ICC target board to achieve the necessary horizontal adjustment.
3. Adjust the ICC target board leveling screws to achieve the necessary vertical adjustment.

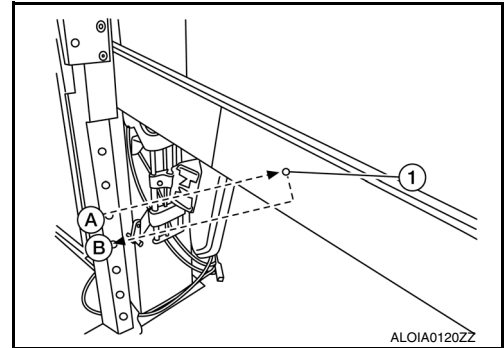

4. The figure shown illustrates the laser beam (A) emitted by the laser assembly (1) and its reflection (B) off of the ICC target board arm.

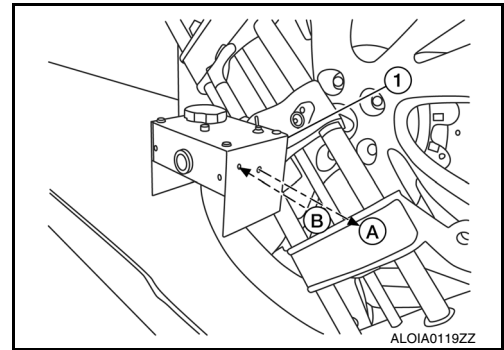

>> GO TO 2.

2. CHECK THE POSITION OF THE ICC TARGET BOARD

Do not place anything other than the ICC target board in the space shown in front of the vehicle (view from top).

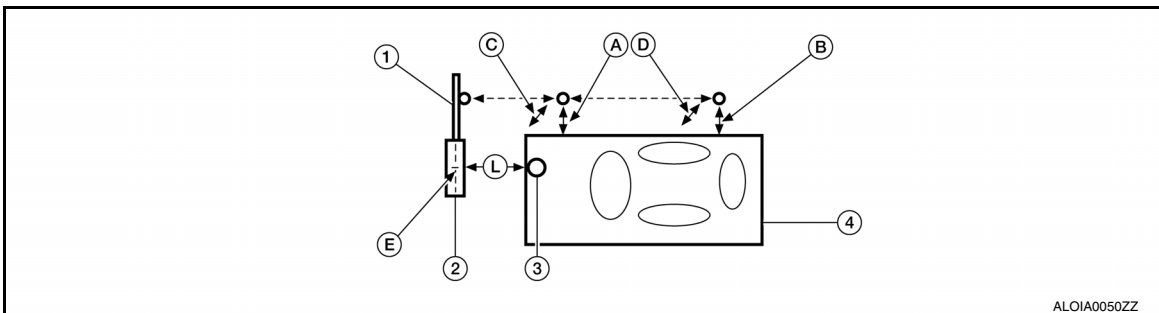

- ① ICC target board arm
- ② ICC target board
- ③ ICC sensor
- ④ Vehicle

A
B
C
D
E
F
G
H
I
J
K
L
M
N
P



ICC SENSOR ALIGNMENT

[ICC]

< BASIC INSPECTION >

- | | | |
|---|--|--|
| Ⓐ Distance between front wheel and laser beam (D _f) | Ⓑ Distance between rear wheel and laser beam (D _r) | Ⓒ Height between front laser beam and ground (H _f) |
| Ⓓ Height between rear laser beam and ground (H _r) | Ⓔ ICC target board center position | Ⓖ 1010 - 1110 mm (39.76 - 43.7 in) |

>> Refer to [CCS-142, "TYPE 2 : ICC Sensor Adjustment"](#).

TYPE 2 : ICC Sensor Adjustment

INFOID:000000013711824

DESCRIPTION

The radar alignment is performed automatically with CONSULT.

CAUTION:

Perform all necessary work for radar alignment until the adjustment completes as shown in the procedure. If the procedure does not complete, the ICC system is inoperable.

1. PERFORM RADAR ALIGNMENT

1. Start the engine.
2. Connect CONSULT and select "Work support" of "LASER/RADAR".
3. Select "MILLIWAVE RADAR ADJUST" after the "Work support" screen is displayed.

NOTE:

Confirm the following items;

- The target should be accurately placed.
- The vehicle should be stopped.

4. Select "Start" after the "MILLIWAVE RADAR ADJUST" screen is displayed.

CAUTION:

Never select "Start" when the target is not accurately placed.

5. Select "Start" after the preparation information is displayed.
6. Select "Next" after the "Starting alignment." screen is displayed.

NOTE:

If the radar is in alignment at this time, "Alignment in progress" is displayed. It may take several 10s of seconds until the result is displayed.

7. Confirm the displayed item.
 - "Alignment completed.": Go to 8.
 - Except "Alignment completed.": Perform the following services.

Displayed item	Possible cause	Service procedure
Alignment condition is not ready.	<ul style="list-style-type: none"> • DTC is detected (Except C1A12). • The position of the ICC target board is not correct. • Vehicle is moving. 	Check the vehicle condition and perform radar alignment again.
Alignment condition is not ready. (Stop the vehicle.)	Vehicle is moving.	Stop the vehicle and perform radar alignment again.
Target is not detected.	<ul style="list-style-type: none"> • A target is not-yet-placed. (The ICC sensor cannot detect target) • The position of the ICC target board is not correct. • The position of the ICC sensor is not correct. 	Check the target board condition and perform radar alignment again.
Sensor malfunction.	ICC sensor malfunction.	Check the vehicle condition and perform radar alignment again.

NOTE:

Replace ICC sensor if "Sensor malfunction." is repeatedly indicated.

8. Confirm displayed value.

ICC SENSOR ALIGNMENT

< BASIC INSPECTION >

[ICC]

Displayed item	Monitor item	Reference value
Alignment completed.	FACTORY AIM L/R	Less than ± 2.00 deg
	FACTORY AIM U/D	Less than ± 2.00 deg
	AIMING VALUE L/R	Less than ± 2.00 deg
	AIMING VALUE U/D	Less than ± 2.00 deg

- Within reference value: Go to 9.
- Outside of reference value: Check the target board condition and perform radar alignment again.

NOTE:

- Check the condition of the ICC sensor installation.
 - Check the vehicle for damage.
 - Replace ICC sensor if it is outside the reference value, even when ICC sensor installation is installed normally and the vehicle is not damaged.
9. Select "OK" after the "No error detected." is displayed.
10. Select "OK" after the "End of alignment." is displayed.

CAUTION:

Once "MILLIWAVE RADAR ADJUST" is started with CONSULT, always continue the work until the horizontal radar alignment is completed successfully. If the job is stopped midway, the radar alignment is not adjusted and the ICC system cannot operate.

>> RADAR ALIGNMENT END

A
B
C
D
E
F
G
H
I
J
K
L
M
N
P

CCS

ACTION TEST

Description

INFOID:000000013711825

Always perform the ICC system action test to check that the ICC system operates normally after replacing the ICC sensor or repairing any ICC system malfunction.

CAUTION:

- Always drive safely when performing the action test.
- Turn the DCA system to OFF when performing the action test.

Work Procedure (Vehicle-To-Vehicle Distance Control Mode)

INFOID:000000013711826

NOTE:

- When there is no vehicle ahead, drive at the set speed steadily.
- When there is a vehicle ahead, control to maintain distance from the vehicle ahead, watching its speed.
- The running speed can be set between 32 km/h (20 MPH) and 144 km/h (90 MPH).

CAUTION:

Never set the cruise speed exceeding the posted speed limit.

1. CHECK FOR MAIN SWITCH

1. Start the engine.
2. Press the MAIN switch ① (less than 1.5 seconds).

Information display status	
MAIN switch indicator ②	: ON
Set distance indicator ③	: Long mode
Set vehicle speed indicator ④	: " _ _ _ "
	: "km/h" ("MPH")

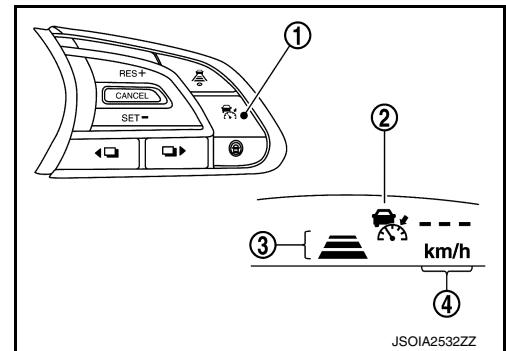

3. Check the ICC system display on the information display to check that the vehicle-to-vehicle distance control mode is ready for activation.
4. Press the MAIN switch, and check that the ICC system display on the information display turns OFF when the ICC system is deactivated.
5. Check that the ICC system display on the information display turns OFF after starting the engine again.

>> GO TO 2.

2. CHECK FOR DISTANCE SWITCH



1. Start the engine.
2. Press the MAIN switch (less than 1.5 seconds).
3. Press the DISTANCE switch.

ACTION TEST

< BASIC INSPECTION >

[ICC]

4. Check that the set distance indicator changes display in order of: (Long)→(Middle)→(Short).

Distance	Display	Approximate distance at 100 km/h (60 MPH) [m (ft)]
Long	 100 km/h	60 (200)
Middle	 100 km/h	45 (150)
Short	 100 km/h	30 (90)

JSOIA1051GB

NOTE:

When the MAIN switch is turned ON, initial setting set to (Long).

>> GO TO 3.

3. CHECK FOR RESUME/ACCELERATE, SET/COAST, AND CANCEL SWITCHES

1. Check that RESUME/ACCELERATE, SET/COAST, CANCEL switches are operated smoothly.
2. Check that switches come up as hand is released from the switches.

>> GO TO 4.

4. SET CHECKING (1)

1. Start the engine.
2. Press the MAIN switch (less than 1.5 seconds) and turn the vehicle-to-vehicle distance control mode ON.
3. Drive the vehicle at 32 km/h (20 MPH) or more.
4. Push down the SET/COAST switch.
5. Check that the desired speed is set and vehicle-to-vehicle distance control mode control starts when releasing SET/COAST switch.

NOTE:

The set vehicle speed is indicated on the set vehicle speed indicator in the ICC system display on the information display.

>> GO TO 5.

5. CHECK FOR INCREASE OF CRUISING SPEED (1)

1. Set the vehicle-to-vehicle distance control mode at desired speed.
2. Check that the set speed increases by 1 km/h (1 MPH) as RESUME/ACCELERATE switch is pushed up.

NOTE:

The maximum set speed of the vehicle-to-vehicle distance control mode is 144 km/h (90 MPH).

CAUTION:

Never set the cruise speed exceeding the posted speed limit.

>> GO TO 6.

6. CHECK FOR DECREASE OF CRUISING SPEED (1)

1. Set the vehicle-to-vehicle distance control mode at desired speed.
2. Check that the set speed decreases by 1 km/h (1 MPH) as SET/COAST switch is pushed down.

NOTE:

- The minimum set speed is approximately 32 km/h (20 MPH).

A
B
C
D
E
F
G
H
I
J
K
L
M
N
P

CCS

ACTION TEST

< BASIC INSPECTION >

[ICC]

- Cancel the control automatically when the vehicle speed is less than approximately 24 km/h (15 MPH) and when the system does not detect any vehicle ahead.

>> GO TO 7.

7.SET CHECKING (2)

1. Stop the vehicle.
2. Drive the vehicle at less than approximately 32 km/h (20 MPH).
3. Push down the SET/COAST switch when the system detects a vehicle ahead.
4. Check that the vehicle-to-vehicle distance control mode is performed so that the vehicle maintains a proper distance according to the vehicle speed [maximum: approximately 32 km/h (20 MPH)] when releasing SET/COAST switch.

NOTE:

- The vehicle-to-vehicle distance control mode cannot be set when the vehicle speed is less than 32 km/h (20 MPH) and when a vehicle ahead is not detected.
- Cancel the control automatically when the vehicle speed is 24 km/h (15 MPH) or less during the control and when the system does not detect any vehicle ahead.
- The set vehicle speed indicator in the ICC system display on the information display is set to 32 km/h (20 MPH).

>> GO TO 8.

8.CHECK FOR INCREASE OF CRUISING SPEED (2)

1. Set the vehicle-to-vehicle distance control mode when the vehicle speed is less than approximately 32 km/h (20 MPH) and when a vehicle ahead is detected.
2. Check that the set speed increases by 1 km/h (1 MPH) as RESUME/ACCELERATE switch is pushed up.

NOTE:

The maximum set speed of the vehicle-to-vehicle distance control mode is 144 km/h (90 MPH).

CAUTION:

Never set the cruise speed exceeding the posted speed limit.

>> GO TO 9.

9.CHECK FOR DECREASE OF CRUISING SPEED INSPECTION (2)

1. Set the vehicle-to-vehicle distance control mode when the vehicle speed is less than approximately 32 km/h (20 MPH) and when a vehicle ahead is detected.
2. Set the set vehicle speed to the desired vehicle speed according to “check for increase of cruising speed”.
3. Check that the set speed decreases by 1 km/h (1 MPH) as SET/COAST switch is pushed down.

NOTE:

- The minimum the set speed is approximately 32 km/h (20 MPH).
- If the vehicle ahead comes to a stop, the vehicle decelerates to a standstill within the limitations of the system. The system will cancel once it judges a standstill with a warning chime.

CAUTION:

The creep occurs because the stop status is not maintained.

>> GO TO 10.

10.CHECK FOR CANCELLATION OF VEHICLE-TO-VEHICLE DISTANCE CONTROL MODE

Check that the vehicle-to-vehicle distance control mode is canceled when performing the following operations.

- When the brake pedal is depressed after vehicle-to-vehicle distance control mode is set and the vehicle is driven.
- When the selector lever is in the “N” position after vehicle-to-vehicle distance control mode is set and the vehicle is driven.
- When the MAIN switch is turned OFF after vehicle-to-vehicle distance control mode is set and the vehicle is driven.
- When the CANCEL switch is pressed after vehicle-to-vehicle distance control mode is set and the vehicle is driven.

>> GO TO 11.

ACTION TEST

< BASIC INSPECTION >

[ICC]

11. CHECK FOR RESTORING SPEED THAT IS SET BY VEHICLE-TO-VEHICLE DISTANCE CONTROL MODE BEFORE CANCELLATION

Check that the vehicle restores the previous speed kept before the system deactivation when performing the following operations.

- Drive the vehicle when the vehicle-to-vehicle distance control mode is set and depress the brake pedal to cancel the control. Check that the vehicle restores the previous vehicle speed kept before the system deactivation when pushing up the RESUME/ACCELERATE switch.
- Drive the vehicle when the vehicle-to-vehicle distance control mode is set and shift the selector lever to the "N" position to cancel the control. Check that the vehicle restores the previous vehicle speed kept before the system deactivation when shifting the selector lever to the "D" position and pushing up the RESUME/ACCELERATE switch.
- Drive the vehicle when the vehicle-to-vehicle distance control mode is set and press the CANCEL switch to cancel the control. Check that the vehicle restores the previous vehicle speed kept before the system deactivation when pushing up the RESUME/ACCELERATE switch.

>> INSPECTION END

Work Procedure [Conventional (Fixed Speed) Cruise Control Mode]

INFOID:000000013711827

NOTE:

The running speed can be set between 40 km/h (25 MPH) and 144 km/h (90 MPH)

CAUTION:

Never set the cruise speed exceeding the posted speed limit.

1. CHECK FOR MAIN SWITCH

1. Start the engine.
2. Press the MAIN switch ① (1.5 seconds or more).

Information display status	:	ON
MAIN switch indicator ②	:	" _ _ _ _ "
Set vehicle speed indicator ③	:	"km/h" ("MPH")

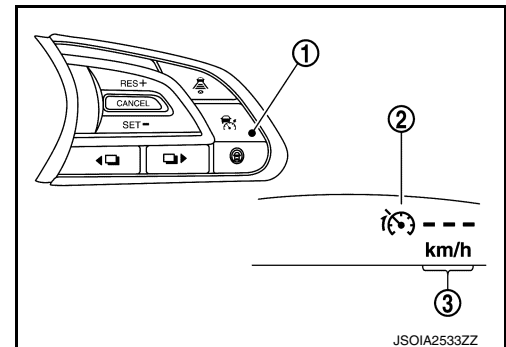

3. Check that the ICC system display on the information display turns on and the display is ready for activation.
4. Press the MAIN switch, and check that the ICC system display on the information display turns OFF when the ICC system is deactivated.
5. Check that the ICC system display on the information display turns OFF after starting the engine again.

>> GO TO 2.

2. CHECK FOR RESUME/ACCELERATE, SET/COAST, AND CANCEL SWITCHES

1. Check that RESUME/ACCELERATE, SET/COAST, CANCEL switches are operated smoothly.
2. Check that switches come up as hand is released from the switches.

>> GO TO 3.

3. SET CHECKING

1. Start the engine.
2. Press the MAIN switch (1.5 seconds or more) and turn the conventional (fixed speed) cruise control mode to ON.
3. Drive the vehicle at 40 km/h (25 MPH) or more.
4. Push down the SET/COAST switch.

A
B
C
D
E
F
G
H
I
J
K
L
M
N
P

ACTION TEST

< BASIC INSPECTION >

[ICC]

5. Check that the desired speed is set and conventional (fixed speed) cruise control mode control starts when releasing SET/COAST switch.

NOTE:

- The set vehicle speed is not displayed in the ICC system display on the information display.
- Display the set status in the ICC system display on the information display.

>> GO TO 4.

4. CHECK FOR INCREASE OF CRUISING SPEED

1. Set the vehicle speed to any desired speed, and drive the vehicle.
2. Check that the set speed increases by 1.6 km/h (1 MPH) as RESUME/ACCELERATE switch is pushed up.

NOTE:

- The maximum set speed is 144 km/h (90 MPH).
- The set vehicle speed increases while pushing up the RESUME/ACCELERATE switch.

CAUTION:

Never set the cruise speed exceeding the posted speed limit.

>> GO TO 5.

5. CHECK FOR DECREASE OF CRUISING SPEED

1. Set the vehicle speed to any desired speed, and drive the vehicle.
2. Check that the set speed decreases by 1.6 km/h (1 MPH) as SET/COAST switch is pushed down.

NOTE:

- The minimum set speed is 40 km/h (25 MPH).
- The set vehicle speed decreases while pressing down the SET/COAST switch.

>> GO TO 6.

6. CHECK FOR CANCELLATION OF CONVENTIONAL (FIXED SPEED) CRUISE CONTROL MODE

Check that the conventional (fixed speed) cruise control mode is canceled when performing the following operations.

- When the brake pedal is depressed after the conventional (fixed speed) cruise control mode is set and the vehicle is driven.
- When the selector lever is in the "N" position after the conventional (fixed speed) cruise control mode is set and the vehicle is driven.
- When the MAIN switch is turned OFF after the conventional (fixed speed) cruise control mode is set and the vehicle is driven.
- When the CANCEL switch is pressed after the conventional (fixed speed) cruise control mode is set and the vehicle is driven.

>> GO TO 7.

7. CHECK FOR RESTORING SPEED THAT IS SET BY CONVENTIONAL (FIXED SPEED) CRUISE CONTROL MODE BEFORE CANCELLATION

Check that the vehicle restores the previous speed kept before the system deactivation when performing the following operations.

- Drive the vehicle when the conventional (fixed speed) cruise control mode is set and depress the brake pedal to cancel the control. Check that the vehicle restores the previous vehicle speed kept before the system deactivation when pushing up the RESUME/ACCELERATE switch at the vehicle speed approximately 40 km/h (25 MPH) or more.
- Drive the vehicle when the conventional (fixed speed) cruise control mode is set and shift the selector lever is in the "N" position to cancel the control. Check that the vehicle restores the previous vehicle speed kept before the system deactivation when shifting the selector lever is in the "D" position and pushing up the RESUME/ACCELERATE switch at the vehicle speed of approximately 40 km/h (25 MPH) or more.
- Drive the vehicle when the conventional (fixed speed) cruise control mode is set and press the CANCEL switch to cancel the control. Check that the vehicle restores the previous vehicle speed kept before the system deactivation when pushing up the RESUME/ACCELERATE switch at the vehicle speed of approximately 40 km/h (25 MPH) or more.

ACTION TEST

< BASIC INSPECTION >

[ICC]

>> INSPECTION END

A

B

C

D

E

F

G

H

I

J

K

L

M

N

CCS

P

DTC/CIRCUIT DIAGNOSIS

C1A00 CONTROL UNIT

DTC Description

INFOID:000000013711828

DTC DETECTION LOGIC

DTC No.	CONSULT screen items (Trouble diagnosis content)	DTC detection condition	
C1A00	CONTROL UNIT (Control unit malfunction)	Diagnosis condition	When engine is running
		Signal (terminal)	—
		Threshold	ICC sensor internal malfunction
		Diagnosis delay time	5 seconds or more

POSSIBLE CAUSE

ICC sensor

FAIL-SAFE

The following systems are canceled.

- Vehicle-to-vehicle distance control mode
- Conventional (fixed speed) cruise control mode
- Distance Control Assist (DCA)
- Forward Emergency Braking (FEB)
- Predictive Forward Collision Warning (PFCW)

DTC CONFIRMATION PROCEDURE

1. PERFORM DTC CONFIRMATION PROCEDURE

1. Start the engine.
2. Perform "All DTC Reading" with CONSULT.
3. Check if the "C1A00" is detected as the current malfunction in "Self Diagnostic Result" of "LASER/RADAR".

Is "C1A00" detected as the current malfunction?

- YES >> Refer to [CCS-150, "Diagnosis Procedure"](#).
- NO-1 >> To check malfunction symptom before repair: Refer to [GI-44, "Intermittent Incident"](#).
- NO-2 >> Confirmation after repair: INSPECTION END

Diagnosis Procedure

INFOID:000000013711829

1. CHECK SELF-DIAGNOSIS RESULTS

Check if any DTC other than "C1A00" is detected in "Self Diagnostic Result" of "LASER/RADAR".

Is any DTC detected?

- YES >> Perform diagnosis on the detected DTC and repair or replace the malfunctioning parts. Refer to [CCS-88, "DTC Index"](#).
- NO >> Replace the ICC sensor. Refer to [CCS-190, "Removal and Installation"](#).

C1A01 POWER SUPPLY CIRCUIT 1, C1A02 POWER SUPPLY CIRCUIT 2

< DTC/CIRCUIT DIAGNOSIS >

[ICC]

C1A01 POWER SUPPLY CIRCUIT 1, C1A02 POWER SUPPLY CIRCUIT 2

DTC Description

INFOID:0000000013711830

DTC DETECTION LOGIC

DTC No.	CONSULT screen items (Trouble diagnosis content)	DTC detection condition	
C1A01	POWER SUPPLY CIR (Power supply circuit)	Diagnosis condition	<ul style="list-style-type: none">When engine is runningWhen MAIN switch of ICC system is ON
		Signal (terminal)	Battery power supply
		Threshold	The battery voltage sent to ICC sensor remains less than 7.9 V
		Diagnosis delay time	5 seconds
C1A02	POWER SUPPLY CIR 2 (Power supply circuit 2)	Diagnosis condition	<ul style="list-style-type: none">When engine is runningWhen MAIN switch of ICC system is ON
		Signal (terminal)	Battery power supply
		Threshold	The battery voltage sent to ICC sensor remains more than 19.3 V
		Diagnosis delay time	5 seconds

POSSIBLE CAUSE

- Connector, harness, fuse
- ICC sensor

FAIL-SAFE

The following systems are canceled.

- Vehicle-to-vehicle distance control mode
- Conventional (fixed speed) cruise control mode
- Distance Control Assist (DCA)
- Forward Emergency Braking (FEB)
- Predictive Forward Collision Warning (PFCW)

DTC CONFIRMATION PROCEDURE

1. PERFORM DTC CONFIRMATION PROCEDURE

- Start the engine.
- Turn the MAIN switch of ICC system ON.
- Perform "All DTC Reading" with CONSULT.
- Check if the "C1A01" or "C1A02" is detected as the current malfunction in "Self Diagnostic Result" of "LASER/RADAR".

Is "C1A01" or "C1A02" detected as the current malfunction?

- YES >> Refer to [CCS-151, "Diagnosis Procedure"](#).
- NO-1 >> To check malfunction symptom before repair: Refer to [GI-44, "Intermittent Incident"](#).
- NO-2 >> Confirmation after repair: INSPECTION END

Diagnosis Procedure

INFOID:0000000013711831

1. CHECK ICC SENSOR POWER SUPPLY AND GROUND CIRCUIT

Check power supply and ground circuit of ICC sensor. Refer to [CCS-173, "Diagnosis Procedure"](#).

Is the inspection result normal?

- YES >> Replace the ICC sensor. Refer to [CCS-190, "Removal and Installation"](#).
- NO >> Repair or replace the malfunctioning parts.

C1A12 RADAR OFF-CENTER

< DTC/CIRCUIT DIAGNOSIS >

[ICC]

C1A12 RADAR OFF-CENTER

DTC Description

INFOID:000000013711832

DTC DETECTION LOGIC

DTC No.	CONSULT screen items (Trouble diagnosis content)	DTC detection condition	
C1A12	RADAR OFF-CENTER (Radar off-center)	Diagnosis condition	<ul style="list-style-type: none">When MAIN switch of ICC system is ONWhen driving the vehicle at 25 km/h (16 MPH) or faster for approximately 15 – 60 minutes or more.
		Signal (terminal)	—
		Threshold	Radar of ICC sensor is off the aiming point
		Diagnosis delay time	30 minutes or more

POSSIBLE CAUSE

Radar is off the aiming point

FAIL-SAFE

The following systems are canceled.

- Vehicle-to-vehicle distance control mode
- Distance Control Assist (DCA)
- Forward Emergency Braking (FEB)
- Predictive Forward Collision Warning (PFCW)

DTC CONFIRMATION PROCEDURE

1. PERFORM DTC CONFIRMATION PROCEDURE

- Start the engine.
- Turn the MAIN switch of ICC system ON.
- Drive the vehicle at 25 km/h (16 MPH) or faster for approximately 15 – 60 minutes or more.
- Perform "All DTC Reading" with CONSULT.
- Check if the "C1A12" is detected as the current malfunction in "Self Diagnostic Result" of "LASER/RADAR".

Is "C1A12" detected as the current malfunction?

- YES >> Refer to [CCS-152, "Diagnosis Procedure"](#).
NO-1 >> To check malfunction symptom before repair: Refer to [GI-44, "Intermittent Incident"](#).
NO-2 >> Confirmation after repair: INSPECTION END

Diagnosis Procedure

INFOID:000000013711833

1. ADJUST RADAR AIMING

- Adjust the radar beam aiming with CONSULT. Refer to [CCS-132, "TYPE 1 : Description"](#).
- Perform "All DTC Reading".
- Check if the "C1A12" is detected in "Self Diagnostic Result" of "LASER/RADAR".

Is "C1A12" detected?

- YES >> Replace the ICC sensor. Refer to [CCS-190, "Removal and Installation"](#).
NO >> INSPECTION END

C1A16 RADAR BLOCKED

< DTC/CIRCUIT DIAGNOSIS >

[ICC]

C1A16 RADAR BLOCKED

DTC Description

INFOID:0000000013711834

DTC DETECTION LOGIC

DTC No.	CONSULT screen items (Trouble diagnosis content)	DTC detection condition	
C1A16	RADAR BLOCKED (Radar blocked)	Diagnosis condition	<ul style="list-style-type: none">When MAIN switch of ICC system is ONWhen driving the vehicle 2km or more.
		Signal (terminal)	—
		Threshold	Inclusion of dirt or stains on the ICC sensor area of the front bumper
		Diagnosis delay time	60 seconds or more

NOTE:

DTC "C1A16" may be detected under the following conditions. (Explain to the customer about the difference between the contamination detection function and the indication when the malfunction is detected and tell them "This is not malfunction".)

- When contamination or foreign materials adhere to the ICC sensor area of the front bumper
- When driving while it is snowing or when frost forms on the ICC sensor area of the front bumper
- When ICC sensor area of the front bumper is temporarily fogged

POSSIBLE CAUSE

- Stain or foreign materials is deposited
- Cracks or scratches exist

FAIL-SAFE

The following systems are canceled.

- Vehicle-to-vehicle distance control mode
- Distance Control Assist (DCA)
- Forward Emergency Braking (FEB)
- Predictive Forward Collision Warning (PFCW)

DTC CONFIRMATION PROCEDURE

1. PERFORM DTC CONFIRMATION PROCEDURE

- Start the engine.
- Turn the MAIN switch of ICC system ON.
- Drive the vehicle 2 km or more.
- Perform "All DTC Reading" with CONSULT.
- Check if the "C1A16" is detected as the current malfunction in "Self Diagnostic Result" of "LASER/RADAR".

Is "C1A16" detected as the current malfunction?

- YES >> Refer to [CCS-153, "Diagnosis Procedure"](#).
- NO-1 >> To check malfunction symptom before repair: Refer to [GI-44, "Intermittent Incident"](#).
- NO-2 >> Confirmation after repair: INSPECTION END

Diagnosis Procedure

INFOID:0000000013711835

CCS

1. VISUAL CHECK 1

Check the contamination and foreign matter on the ICC sensor area of the front bumper.

Does contamination or foreign materials adhere?

- YES >> Wipe out the contamination and foreign matter on the ICC sensor area of the front bumper.
- NO >> GO TO 2.

2. VISUAL CHECK 2

- Remove the front bumper. Refer to [EXT-23, "Removal and Installation"](#).
- Check ICC sensor for contamination and foreign matter.

C1A16 RADAR BLOCKED

[ICC]

< DTC/CIRCUIT DIAGNOSIS >

Does contamination or foreign matter adhere?

- YES >> Wipe out the contamination and foreign matter from the ICC sensor.
- NO >> GO TO 3.

3.VISUAL CHECK 3

Check ICC sensor for cracks and scratches.

Is it found?

- YES >> Replace the ICC sensor. Refer to [CCS-190. "Removal and Installation"](#).
- NO >> GO TO 4.

4.PERFORM RADAR ALIGNMENT

1. Adjust the radar alignment with CONSULT. Refer to [CCS-132. "TYPE 1 : Description"](#) (TYPE 1), or [CCS-136. "TYPE 2 : Description"](#) (TYPE 2).
2. Perform ICC system action test to check the operation status. Refer to [CCS-144. "Description"](#)
3. Perform "All DTC Reading".
4. Check the "C1A16" is detected in "Self Diagnostic Result" of "LASER/RADAR".

Is "C1A16" detected?

- YES >> Replace the ICC sensor. Refer to [CCS-190. "Removal and Installation"](#).
- NO >> GO TO 5.

5.INTERVIEW

1. Ask if there is any trace of contamination or foreign materials adhering to the ICC sensor area of the front bumper.
2. Ask if ICC sensor area of the front bumper was frosted during driving or if vehicle was driven in snow.
3. Ask if ICC sensor area of the front bumper was temporarily fogged. (Windshield glass may also tend to fog, etc.)

Is any of above conditions seen?

- YES >> Explain to the customer about the difference between the contamination detection function and the indication when the malfunction is detected and tell them "This is not malfunction".
- NO >> Replace the ICC sensor. Refer to [CCS-190. "Removal and Installation"](#).

C1A21 UNIT HIGH TEMP

< DTC/CIRCUIT DIAGNOSIS >

[ICC]

C1A21 UNIT HIGH TEMP

DTC Description

INFOID:0000000013711836

DTC DETECTION LOGIC

DTC No.	CONSULT screen items (Trouble diagnosis content)	DTC detection condition	
C1A21	UNIT HIGH TEMP (Unit high temperature)	Diagnosis condition	<ul style="list-style-type: none">When engine is runningWhen MAIN switch of ICC system is ON
		Signal (terminal)	—
		Threshold	Temperature detected by the temperature sensor integrated in ICC sensor remains more than 105 °C (221 °F)
		Diagnosis delay time	5 seconds or more

POSSIBLE CAUSE

Temperature around the ICC sensor becomes extremely low or high

FAIL-SAFE

The following systems are canceled.

- Vehicle-to-vehicle distance control mode
- Conventional (fixed speed) cruise control mode
- Distance Control Assist (DCA)
- Forward Emergency Braking (FEB)
- Predictive Forward Collision Warning (PFCW)

DTC CONFIRMATION PROCEDURE

1. PERFORM DTC CONFIRMATION PROCEDURE

- Turn the ignition switch OFF.
- Wait for 10 minutes or more.
- Start the engine.
- Turn the MAIN switch of ICC system ON.
- Perform "All DTC Reading" with CONSULT.
- Check if the "C1A21" is detected as the current malfunction in "Self Diagnostic Result" of "LASER/RADAR".

Is "C1A21" detected as the current malfunction?

- YES >> Refer to [CCS-155, "Diagnosis Procedure"](#).
- NO-1 >> To check malfunction symptom before repair: Refer to [GI-44, "Intermittent Incident"](#).
- NO-2 >> Confirmation after repair: INSPECTION END

Diagnosis Procedure

INFOID:0000000013711837

1. CHECK ENGINE COOLING SYSTEM

Check for any malfunctions in engine cooling system.

Is engine cooling system normal?

- YES >> Replace the ICC sensor. Refer to [CCS-190, "Removal and Installation"](#).
- NO >> Repair engine cooling system.

CCS

C1A23 UNIT LOW TEMP

< DTC/CIRCUIT DIAGNOSIS >

[ICC]

C1A23 UNIT LOW TEMP

DTC Description

INFOID:000000013711838

DTC DETECTION LOGIC

DTC No.	CONSULT screen items (Trouble diagnosis content)	DTC detection condition	
C1A23	UNIT LOW TEMP (Unit low temperature)	Diagnosis condition	<ul style="list-style-type: none">• When engine is running• When MAIN switch of ICC system is ON
		Signal (terminal)	—
		Threshold	Temperature detected by the temperature sensor integrated in ICC sensor remains less than -45 °C (-49 °F)
		Diagnosis delay time	5 seconds or more

POSSIBLE CAUSE

Temperature around the ICC sensor becomes extremely low or high

FAIL-SAFE

The following systems are canceled.

- Vehicle-to-vehicle distance control mode
- Conventional (fixed speed) cruise control mode
- Distance Control Assist (DCA)
- Forward Emergency Braking (FEB)
- Predictive Forward Collision Warning (PFCW)

DTC CONFIRMATION PROCEDURE

1. PERFORM DTC CONFIRMATION PROCEDURE

1. Turn the ignition switch OFF.
2. Wait for 10 minutes or more.
3. Start the engine.
4. Turn the MAIN switch of ICC system ON.
5. Perform "All DTC Reading" with CONSULT.
6. Check if the "C1A23" is detected as the current malfunction in "Self Diagnostic Result" of "LASER/RADAR".

Is "C1A23" detected as the current malfunction?

- YES >> Refer to [CCS-156, "Diagnosis Procedure"](#).
- NO-1 >> To check malfunction symptom before repair: Refer to [GI-44, "Intermittent Incident"](#).
- NO-2 >> Confirmation after repair: INSPECTION END

Diagnosis Procedure

INFOID:000000013711839

1. CHECK ENVIRONMENT CONDITION

Check ambient temperature.

Is ambient temperature 0°C (32°F) or more?

- YES >> Replace the ICC sensor. Refer to [CCS-190, "Removal and Installation"](#).
- NO >> Perform check again at 0°C (32°F) or more.

C1A39 STEERING ANGLE SENSOR

< DTC/CIRCUIT DIAGNOSIS >

[ICC]

C1A39 STEERING ANGLE SENSOR

DTC Description

INFOID:0000000013711840

DTC DETECTION LOGIC

DTC No.	CONSULT screen items (Trouble diagnosis content)	DTC detection condition	
C1A39	STRG SEN CIR (Steering angle sensor circuit)	Diagnosis condition	<ul style="list-style-type: none">• When engine is running• When MAIN switch of ICC system is ON
		Signal (terminal)	—
		Threshold	If the steering angle sensor is malfunction
		Diagnosis delay time	2 seconds or more

POSSIBLE CAUSE

Steering angle sensor

FAIL-SAFE

The following systems are canceled.

- Vehicle-to-vehicle distance control mode
- Conventional (fixed speed) cruise control mode
- Distance Control Assist (DCA)
- Forward Emergency Braking (FEB)
- Predictive Forward Collision Warning (PFCW)

DTC CONFIRMATION PROCEDURE

1.CHECK DTC PRIORITY

If DTC "C1A39" is displayed with DTC "U1000", first diagnose the DTC "U1000".

Is applicable DTC detected?

- YES >> Perform diagnosis of applicable. Refer to [DAS-222, "ADAS CONTROL UNIT : DTC Description"](#).
NO >> GO TO 2.

2.PERFORM DTC CONFIRMATION PROCEDURE

1. Start the engine.
2. Turn the MAIN switch of ICC system ON.
3. Perform "All DTC Reading" with CONSULT.
4. Check if the "C1A39" is detected as the current malfunction in self-diagnosis results of "LASER/RADAR".

Is "C1A39" detected as the current malfunction?

- YES >> Refer to [CCS-157, "Diagnosis Procedure"](#).
NO-1 >> To check malfunction symptom before repair: Refer to [GI-44, "Intermittent Incident"](#).
NO-2 >> Confirmation after repair: INSPECTION END

Diagnosis Procedure

INFOID:0000000013711841

1.CHECK DTC PRIORITY

If DTC "C1A39" is displayed with DTC "U1000", first diagnose the DTC "U1000".

Is applicable DTC detected?

- YES >> Perform diagnosis of applicable. Refer to [DAS-222, "ADAS CONTROL UNIT : DTC Description"](#).
NO >> GO TO 2.

2.CHECK ADAS CONTROL UNIT SELF-DIAGNOSIS RESULTS

Check if any DTC is detected in "Self Diagnostic Result" of "ICC/ADAS".

Is any DTC detected?

- YES >> Perform diagnosis on the detected DTC and repair or replace the malfunctioning parts. Refer to [DAS-67, "DTC Index"](#).
NO >> Replace the ICC sensor. Refer to [CCS-190, "Removal and Installation"](#).

C1A50 ADAS CONTROL UNIT

< DTC/CIRCUIT DIAGNOSIS >

[ICC]

C1A50 ADAS CONTROL UNIT

DTC Description

INFOID:000000013711842

DTC DETECTION LOGIC

DTC No.	CONSULT screen items (Trouble diagnosis content)	DTC detection condition	
C1A50	ADAS MALFUNCTION (ADAS control unit malfunction)	Diagnosis condition	<ul style="list-style-type: none">• When engine is running• When MAIN switch of ICC system is ON
		Signal (terminal)	—
		Threshold	If ADAS control unit is malfunctioning
		Diagnosis delay time	2 seconds or more

POSSIBLE CAUSE

ADAS control unit

FAIL-SAFE

The following systems are canceled.

- Vehicle-to-vehicle distance control mode
- Conventional (fixed speed) cruise control mode
- Distance Control Assist (DCA)
- Forward Emergency Braking (FEB)
- Predictive Forward Collision Warning (PFCW)

DTC CONFIRMATION PROCEDURE

1.CHECK DTC PRIORITY

If DTC "C1A50" is displayed with DTC "U1000", first diagnose the DTC "U1000".

Is applicable DTC detected?

YES >> Perform diagnosis of applicable. Refer to [CCS-171, "DTC Description"](#).

NO >> GO TO 2.

2.PERFORM DTC CONFIRMATION PROCEDURE

1. Start the engine.
2. Turn the MAIN switch of ICC system ON.
3. Perform "All DTC Reading" with CONSULT.
4. Check if the "C1A50" is detected as the current malfunction in "Self Diagnostic Result" of "LASER/RADAR".

Is "C1A50" detected as the current malfunction?

YES >> Refer to [CCS-158, "Diagnosis Procedure"](#).

NO-1 >> To check malfunction symptom before repair: Refer to [GI-44, "Intermittent Incident"](#).

NO-2 >> Confirmation after repair: INSPECTION END

Diagnosis Procedure

INFOID:000000013711843

1.CHECK DTC PRIORITY

If DTC "C1A50" is displayed with DTC "U1000", first diagnose the DTC "U1000".

Is applicable DTC detected?

YES >> Perform diagnosis of applicable. Refer to [CCS-171, "DTC Description"](#).

NO >> GO TO 2.

2.CHECK ADAS CONTROL UNIT SELF-DIAGNOSIS RESULTS

Check if any DTC is detected in "Self Diagnostic Result" of "ICC/ADAS".

Is any DTC detected?

YES >> Perform diagnosis on the detected DTC and repair or replace the malfunctioning parts. Refer to [DAS-67, "DTC Index"](#).

NO >> Replace the ICC sensor. Refer to [CCS-190, "Removal and Installation"](#).

U0104 ADAS CAN 1

DTC Description

INFOID:0000000013711844

DTC DETECTION LOGIC

DTC No.	CONSULT screen items (Trouble diagnosis content)	DTC detection condition	
U0104	ADAS CAN CIR 1 (ADAS control unit CAN circuit 1)	Diagnosis condition	<ul style="list-style-type: none"> When engine is running When MAIN switch of ICC system is ON
		Signal (terminal)	—
		Threshold	If ICC sensor detects an error signal that is received from ADAS control unit via ITS communication
		Diagnosis delay time	2 seconds or more

POSSIBLE CAUSE

ADAS control unit

FAIL-SAFE

The following systems are canceled.

- Vehicle-to-vehicle distance control mode
- Conventional (fixed speed) cruise control mode
- Distance Control Assist (DCA)
- Forward Emergency Braking (FEB)
- Predictive Forward Collision Warning (PFCW)

DTC CONFIRMATION PROCEDURE

1. CHECK DTC PRIORITY

If DTC “U0104” is displayed with DTC “U1000”, first diagnose the DTC “U1000”.

Is applicable DTC detected?

YES >> Perform diagnosis of applicable. Refer to [CCS-171, "DTC Description"](#).

NO >> GO TO 2.

2. PERFORM DTC CONFIRMATION PROCEDURE

1. Start the engine.
2. Turn the MAIN switch of ICC system ON.
3. Perform “All DTC Reading” with CONSULT.
4. Check if the “U0104” is detected as the current malfunction in “Self Diagnostic Result” of “LASER/RADAR”.

Is “U0104” detected as the current malfunction?

YES >> Refer to [CCS-159, "Diagnosis Procedure"](#).

NO-1 >> To check malfunction symptom before repair: Refer to [GI-44, "Intermittent Incident"](#).

NO-2 >> Confirmation after repair: INSPECTION END

Diagnosis Procedure

INFOID:0000000013711845

1. CHECK DTC PRIORITY

If DTC “U0104” is displayed with DTC “U1000”, first diagnose the DTC “U1000”.

Is applicable DTC detected?

YES >> Perform diagnosis of applicable. Refer to [CCS-171, "DTC Description"](#).

NO >> GO TO 2.

2. CHECK ADAS CONTROL UNIT SELF-DIAGNOSIS RESULTS

Check if any DTC is detected in “Self Diagnostic Result” of “ICC/ADAS”.

Is any DTC detected?

YES >> Perform diagnosis on the detected DTC and repair or replace the malfunctioning parts. Refer to [DAS-67, "DTC Index"](#).

A
B
C
D
E
F
G
H
I
J
K
L
M
N
P



U0104 ADAS CAN 1

< DTC/CIRCUIT DIAGNOSIS >

[ICC]

NO >> Replace the ICC sensor. Refer to [CCS-190. "Removal and Installation"](#).

U0121 VDC CAN 2

< DTC/CIRCUIT DIAGNOSIS >

[ICC]

U0121 VDC CAN 2

DTC Description

INFOID:0000000013711846

DTC DETECTION LOGIC

DTC No.	CONSULT screen items (Trouble diagnosis content)	DTC detection condition	
U0121	VDC CAN CIR2 (VDC CAN circuit2)	Diagnosis condition	<ul style="list-style-type: none">• When engine is running• When MAIN switch of ICC system is ON
		Signal (terminal)	—
		Threshold	If ICC sensor detects an error signal that is received from ABS actuator and electric unit (control unit) via ADAS control unit
		Diagnosis delay time	2 seconds or more

POSSIBLE CAUSE

ABS actuator and electric unit (control unit)

FAIL-SAFE

The following systems are canceled.

- Vehicle-to-vehicle distance control mode
- Conventional (fixed speed) cruise control mode
- Distance Control Assist (DCA)
- Forward Emergency Braking (FEB)
- Predictive Forward Collision Warning (PFCW)

DTC CONFIRMATION PROCEDURE

1. CHECK DTC PRIORITY

If DTC "U0121" is displayed with DTC "U1000", first diagnose the DTC "U1000".

Is applicable DTC detected?

- YES >> Perform diagnosis of applicable. Refer to [CCS-171, "DTC Description"](#).
NO >> GO TO 2.

2. PERFORM DTC CONFIRMATION PROCEDURE

1. Start the engine.
2. Turn the MAIN switch of ICC system ON.
3. Perform "All DTC Reading" with CONSULT.
4. Check if the "U0121" is detected as the current malfunction in "Self Diagnostic Result" of "LASER/RADAR".

Is "U0121" detected as the current malfunction?

- YES >> Refer to [CCS-161, "Diagnosis Procedure"](#).
NO-1 >> To check malfunction symptom before repair: Refer to [GI-44, "Intermittent Incident"](#).
NO-2 >> Confirmation after repair: INSPECTION END

Diagnosis Procedure

INFOID:0000000013711847

1. CHECK DTC PRIORITY

If DTC "U0121" is displayed with DTC "U1000", first diagnose the DTC "U1000".

Is applicable DTC detected?

- YES >> Perform diagnosis of applicable. Refer to [CCS-171, "DTC Description"](#).
NO >> GO TO 2.

2. CHECK ADAS CONTROL UNIT SELF-DIAGNOSIS RESULTS

Check if any DTC is detected in "Self Diagnostic Result" of "ICC/ADAS".

Is any DTC detected?

A
B
C
D
E
F
G
H
I
J
K
L
M
N

CCS

P

U0121 VDC CAN 2

< DTC/CIRCUIT DIAGNOSIS >

[ICC]

-
- YES >> Perform diagnosis on the detected DTC and repair or replace the malfunctioning parts. Refer to [DAS-67, "DTC Index"](#).
- NO >> Replace the ICC sensor. Refer to [CCS-190, "Removal and Installation"](#).

U0126 STRG SEN CAN 1

DTC Description

INFOID:0000000013711848

DTC DETECTION LOGIC

DTC No.	CONSULT screen items (Trouble diagnosis content)	DTC detection condition	
U0126	STRG SEN CAN CIR1 (Steering angle sensor CAN circuit1)	Diagnosis condition	<ul style="list-style-type: none"> When engine is running When MAIN switch of ICC system is ON
		Signal (terminal)	—
		Threshold	If ICC sensor detects an error signal that is received from steering angle sensor via ADAS control unit
		Diagnosis delay time	2 seconds or more

POSSIBLE CAUSE

Steering angle sensor error

FAIL-SAFE

The following systems are canceled.

- Vehicle-to-vehicle distance control mode
- Conventional (fixed speed) cruise control mode
- Distance Control Assist (DCA)
- Forward Emergency Braking (FEB)
- Predictive Forward Collision Warning (PFCW)

DTC CONFIRMATION PROCEDURE

1. CHECK DTC PRIORITY

If DTC "U0126" is displayed with DTC "U1000", first diagnose the DTC "U1000".

Is applicable DTC detected?

- YES >> Perform diagnosis of applicable. Refer to [CCS-171, "DTC Description"](#).
 NO >> GO TO 2.

2. PERFORM DTC CONFIRMATION PROCEDURE

1. Start the engine.
2. Turn the MAIN switch of ICC system ON.
3. Perform "All DTC Reading" with CONSULT.
4. Check if the "U0126" is detected as the current malfunction in "Self Diagnostic Result" of "LASER/RADAR".

Is "U0126" detected as the current malfunction?

- YES >> Refer to [CCS-163, "Diagnosis Procedure"](#).
 NO-1 >> To check malfunction symptom before repair: Refer to [GI-44, "Intermittent Incident"](#).
 NO-2 >> Confirmation after repair: INSPECTION END

Diagnosis Procedure

INFOID:0000000013711849

1. CHECK DTC PRIORITY

If DTC "U0126" is displayed with DTC "U1000", first diagnose the DTC "U1000".

Is applicable DTC detected?

- YES >> Perform diagnosis of applicable. Refer to [CCS-171, "DTC Description"](#).
 NO >> GO TO 2.

2. CHECK ADAS CONTROL UNIT SELF-DIAGNOSIS RESULTS

Check if any DTC is detected in "Self Diagnostic Result" of "ICC/ADAS".

Is any DTC detected?

- YES >> Perform diagnosis on the detected DTC and repair or replace the malfunctioning parts. Refer to [DAS-67, "DTC Index"](#).

U0126 STRG SEN CAN 1

< DTC/CIRCUIT DIAGNOSIS >

[ICC]

NO >> Replace the ICC sensor. Refer to [CCS-190. "Removal and Installation"](#).

U0405 ADAS CAN 2

DTC Description

INFOID:0000000013711850

DTC DETECTION LOGIC

DTC No.	CONSULT screen items (Trouble diagnosis content)	DTC detection condition	
U0405	ADAS CAN CIR 2 (ADAS control unit CAN circuit 2)	Diagnosis condition	<ul style="list-style-type: none"> When engine is running When MAIN switch of ICC system is ON
		Signal (terminal)	—
		Threshold	If ICC sensor detects an error signal that is received from ADAS control unit via ITS communication
		Diagnosis delay time	2 seconds or more

POSSIBLE CAUSE

ADAS control unit

FAIL-SAFE

The following systems are canceled.

- Vehicle-to-vehicle distance control mode
- Conventional (fixed speed) cruise control mode
- Distance Control Assist (DCA)
- Forward Emergency Braking (FEB)
- Predictive Forward Collision Warning (PFCW)

DTC CONFIRMATION PROCEDURE

1.CHECK DTC PRIORITY

If DTC “U0405” is displayed with DTC “U1000”, first diagnose the DTC “U1000”.

Is applicable DTC detected?

YES >> Perform diagnosis of applicable. Refer to [CCS-171, "DTC Description"](#).

NO >> GO TO 2.

2.PERFORM DTC CONFIRMATION PROCEDURE

1. Start the engine.
2. Turn the MAIN switch of ICC system ON.
3. Perform “All DTC Reading” with CONSULT.
4. Check if the “U0405” is detected as the current malfunction in “Self Diagnostic Result” of “LASER/RADAR”.

Is “U0405” detected as the current malfunction?

YES >> Refer to [CCS-165, "Diagnosis Procedure"](#).

NO-1 >> To check malfunction symptom before repair: Refer to [GI-44, "Intermittent Incident"](#).

NO-2 >> Confirmation after repair: INSPECTION END

Diagnosis Procedure

INFOID:0000000013711851

1.CHECK DTC PRIORITY

If DTC “U0405” is displayed with DTC “U1000”, first diagnose the DTC “U1000”.

Is applicable DTC detected?

YES >> Perform diagnosis of applicable. Refer to [CCS-171, "DTC Description"](#).

NO >> GO TO 2.

2.CHECK ADAS CONTROL UNIT SELF-DIAGNOSIS RESULTS

Check if any DTC is detected in “Self Diagnostic Result” of “ICC/ADAS”.

Is any DTC detected?

YES >> Perform diagnosis on the detected DTC and repair or replace the malfunctioning parts. Refer to [DAS-67, "DTC Index"](#).

A
B
C
D
E
F
G
H
I
J
K
L
M
N
P



U0405 ADAS CAN 2

< DTC/CIRCUIT DIAGNOSIS >

[ICC]

NO >> Replace the ICC sensor. Refer to [CCS-190. "Removal and Installation"](#).

U0415 VDC CAN 1

< DTC/CIRCUIT DIAGNOSIS >

[ICC]

U0415 VDC CAN 1

DTC Description

INFOID:0000000013711852

DTC DETECTION LOGIC

DTC No.	CONSULT screen items (Trouble diagnosis content)	DTC detection condition	
U0415	VDC CAN CIR1 (VDC CAN circuit1)	Diagnosis condition	<ul style="list-style-type: none">• When engine is running• When MAIN switch of ICC system is ON
		Signal (terminal)	—
		Threshold	If ICC sensor detects an error signal that is received from ABS actuator and electric unit (control unit) via ADAS control unit
		Diagnosis delay time	2 seconds or more

POSSIBLE CAUSE

ABS actuator and electric unit (control unit)

FAIL-SAFE

The following systems are canceled.

- Vehicle-to-vehicle distance control mode
- Conventional (fixed speed) cruise control mode
- Distance Control Assist (DCA)
- Forward Emergency Braking (FEB)
- Predictive Forward Collision Warning (PFCW)

DTC CONFIRMATION PROCEDURE

1. CHECK DTC PRIORITY

If DTC "U0415" is displayed with DTC "U1000", first diagnose the DTC "U1000".

Is applicable DTC detected?

- YES >> Perform diagnosis of applicable. Refer to [CCS-171, "DTC Description"](#).
NO >> GO TO 2.

2. PERFORM DTC CONFIRMATION PROCEDURE

1. Start the engine.
2. Turn the MAIN switch of ICC system ON.
3. Perform "All DTC Reading" with CONSULT.
4. Check if the "U0415" is detected as the current malfunction in "Self Diagnostic Result" of "LASER/RADAR".

Is "U0415" detected as the current malfunction?

- YES >> Refer to [CCS-167, "Diagnosis Procedure"](#).
NO-1 >> To check malfunction symptom before repair: Refer to [GI-44, "Intermittent Incident"](#).
NO-2 >> Confirmation after repair: INSPECTION END

Diagnosis Procedure

INFOID:0000000013711853

1. CHECK DTC PRIORITY

If DTC "U0415" is displayed with DTC "U1000", first diagnose the DTC "U1000".

Is applicable DTC detected?

- YES >> Perform diagnosis of applicable. Refer to [CCS-171, "DTC Description"](#).
NO >> GO TO 2.

2. CHECK ADAS CONTROL UNIT SELF-DIAGNOSIS RESULTS

Check if any DTC is detected in "Self Diagnostic Result" of "ICC/ADAS".

Is any DTC detected?

A
B
C
D
E
F
G
H
I
J
K
L
M
N

CCS

P

U0415 VDC CAN 1

< DTC/CIRCUIT DIAGNOSIS >

[ICC]

-
- YES >> Perform diagnosis on the detected DTC and repair or replace the malfunctioning parts. Refer to [DAS-67, "DTC Index"](#).
- NO >> Replace the ICC sensor. Refer to [CCS-190, "Removal and Installation"](#).

U0428 STRG SEN CAN 2

DTC Description

INFOID:0000000013711854

DTC DETECTION LOGIC

DTC No.	CONSULT screen items (Trouble diagnosis content)	DTC detection condition	
U0428	STRG SEN CAN CIR2 (Steering angle sensor CAN circuit2)	Diagnosis condition	<ul style="list-style-type: none"> When engine is running When MAIN switch of ICC system is ON
		Signal (terminal)	—
		Threshold	If ICC sensor detects an error signal that is received from steering angle sensor via ADAS control unit
		Diagnosis delay time	2 seconds or more

POSSIBLE CAUSE

Steering angle sensor

FAIL-SAFE

The following systems are canceled.

- Vehicle-to-vehicle distance control mode
- Conventional (fixed speed) cruise control mode
- Distance Control Assist (DCA)
- Forward Emergency Braking (FEB)
- Predictive Forward Collision Warning (PFCW)

DTC CONFIRMATION PROCEDURE

1. CHECK DTC PRIORITY

If DTC "U0428" is displayed with DTC "U1000", first diagnose the DTC "U1000".

Is applicable DTC detected?

- YES >> Perform diagnosis of applicable. Refer to [CCS-171, "DTC Description"](#).
 NO >> GO TO 2.

2. PERFORM DTC CONFIRMATION PROCEDURE

1. Start the engine.
2. Turn the MAIN switch of ICC system ON.
3. Perform "All DTC Reading" with CONSULT.
4. Check if the "U0428" is detected as the current malfunction in "Self Diagnostic Result" of "LASER/RADAR".

Is "U0428" detected as the current malfunction?

- YES >> Refer to [CCS-169, "Diagnosis Procedure"](#).
 NO-1 >> To check malfunction symptom before repair: Refer to [GI-44, "Intermittent Incident"](#).
 NO-2 >> Confirmation after repair: INSPECTION END

Diagnosis Procedure

INFOID:0000000013711855

1. CHECK DTC PRIORITY

If DTC "U0428" is displayed with DTC "U1000", first diagnose the DTC "U1000".

Is applicable DTC detected?

- YES >> Perform diagnosis of applicable. Refer to [CCS-171, "DTC Description"](#).
 NO >> GO TO 2.

2. CHECK ADAS CONTROL UNIT SELF-DIAGNOSIS RESULTS

Check if any DTC is detected in "Self Diagnostic Result" of "ICC/ADAS".

Is any DTC detected?

- YES >> Perform diagnosis on the detected DTC and repair or replace the malfunctioning parts. Refer to [DAS-67, "DTC Index"](#).



U0428 STRG SEN CAN 2

< DTC/CIRCUIT DIAGNOSIS >

[ICC]

NO >> Replace the ICC sensor. Refer to [CCS-190. "Removal and Installation"](#).

U1000 CAN COMM CIRCUIT

< DTC/CIRCUIT DIAGNOSIS >

[ICC]

U1000 CAN COMM CIRCUIT

DTC Description

INFOID:0000000013711857

ITS COMMUNICATION

- ITS communication is a multiplex communication system. This enables the system to transmit and receive large quantities of data at high speed by connecting control units with 2 communication lines.
- ITS communication lines adopt twisted-pair line style (two lines twisted) for noise immunity.

DTC DETECTION LOGIC

DTC No.	CONSULT screen items (Trouble diagnosis content)	DTC detection condition	
U1000	CAN COMM CIRCUIT (CAN communication circuit)	Diagnosis condition	<ul style="list-style-type: none">• When engine is running• When MAIN switch of ICC system is ON
		Signal (terminal)	ITC communication signal
		Threshold	If ICC sensor is not transmitting or receiving ITS communication signal
		Diagnosis delay time	2 seconds or more

POSSIBLE CAUSE

ITS communication system

FAIL-SAFE

The following systems are canceled.

- Vehicle-to-vehicle distance control mode
- Conventional (fixed speed) cruise control mode
- Distance Control Assist (DCA)
- Forward Emergency Braking (FEB)
- Predictive Forward Collision Warning (PFCW)

DTC CONFIRMATION PROCEDURE

1.PERFORM DTC CONFIRMATION PROCEDURE

1. Start the engine.
2. Turn the MAIN switch of ICC system ON.
3. Perform "All DTC Reading" with CONSULT.
4. Check if the "U1000" is detected as the current malfunction in "Self Diagnostic Result" of "ICC/ADAS".

Is "U1000" detected as the current malfunction?

- YES >> Refer to [CCS-171, "Diagnosis Procedure"](#).
- NO-1 >> To check malfunction symptom before repair: Refer to [GI-44, "Intermittent Incident"](#).
- NO-2 >> Confirmation after repair: INSPECTION END

Diagnosis Procedure

INFOID:0000000013711858

1.PERFORM THE SELF-DIAGNOSIS

1. Turn the ignition switch ON.
2. Turn the MAIN switch of ICC system ON, and then wait for 2 seconds or more.
3. Perform "All DTC Reading" with CONSULT.
4. Check if the "U1000" is detected as the current malfunction in "Self Diagnostic Result" of "LASER/RADAR".

Is "U1000" detected as the current malfunction?

- YES >> Refer to [LAN-37, "Trouble Diagnosis Flow Chart"](#).
- NO >> INSPECTION END

U1010 CONTROL UNIT (CAN)

< DTC/CIRCUIT DIAGNOSIS >

[ICC]

U1010 CONTROL UNIT (CAN)

DTC Description

INFOID:000000013711860

CAN controller controls the communication of ITS communication signal and the error detection.

DTC DETECTION LOGIC

DTC No.	CONSULT screen items (Trouble diagnosis content)	DTC detection condition	
U1010	CONTROL UNIT (CAN) [Control unit (CAN)]	Diagnosis condition	<ul style="list-style-type: none">When engine is runningWhen MAIN switch of ICC system is ON
		Signal (terminal)	—
		Threshold	If ICC sensor detects malfunction by CAN controller initial diagnosis
		Diagnosis delay time	5 seconds or more

POSSIBLE CAUSE

ICC sensor

FAIL-SAFE

The following systems are canceled.

- Vehicle-to-vehicle distance control mode
- Conventional (fixed speed) cruise control mode
- Distance Control Assist (DCA)
- Forward Emergency Braking (FEB)
- Predictive Forward Collision Warning (PFCW)

DTC CONFIRMATION PROCEDURE

1. PERFORM DTC CONFIRMATION PROCEDURE

1. Start the engine.
2. Turn the MAIN switch of ICC system ON.
3. Perform "All DTC Reading" with CONSULT.
4. Check if the "U1010" is detected as the current malfunction in "Self Diagnostic Result" of "ICC/ADAS".

Is "U1000" detected as the current malfunction?

- YES >> Refer to [CCS-171, "Diagnosis Procedure"](#).
- NO-1 >> To check malfunction symptom before repair: Refer to [GI-44, "Intermittent Incident"](#).
- NO-2 >> Confirmation after repair: INSPECTION END

Diagnosis Procedure

INFOID:000000013711861

1. PERFORM DTC CONFIRMATION PROCEDURE

1. Turn the MAIN switch of ICC system ON.
2. Perform "All DTC Reading" with CONSULT.
3. Check if the "U1010" is detected as the current malfunction in "Self Diagnostic Result" of "LASER/RADAR".

Is "U1010" detected as the current malfunction?

- YES >> Replace the ICC sensor. Refer to [CCS-190, "Removal and Installation"](#).
- NO >> INSPECTION END

POWER SUPPLY AND GROUND CIRCUIT

< DTC/CIRCUIT DIAGNOSIS >

[ICC]

POWER SUPPLY AND GROUND CIRCUIT

Diagnosis Procedure

INFOID:0000000013711862

1. CHECK FUSES

Check if any of the following fuses are blown:

Signal name	Fuse No.
Ignition power supply (VR30DDTT models)	54
Ignition power supply (2.0L turbo gasoline engine models)	75

Is the inspection result normal?

YES >> GO TO 2.

NO >> Replace the blown fuse after repairing the affected circuit if a fuse is blown.

2. CHECK ICC SENSOR POWER SUPPLY CIRCUIT

Check voltage between ICC sensor harness connector and ground.

Terminal		Condition	Voltage (Approx.)
(+)	(-)		
ICC sensor		Ignition switch	0 V
Connector	Terminal		
E80	1	OFF	0 V
		ON	Battery voltage

Is the inspection result normal?

YES >> GO TO 3.

NO >> Repair the ICC sensor power supply circuit.

3. CHECK ICC SENSOR GROUND CIRCUIT

1. Turn the ignition switch OFF.
2. Disconnect the ICC sensor connector.
3. Check for continuity between ICC sensor harness connector and ground.

ICC sensor		Ground	Continuity
Connector	Terminal		
E80	8		Existed

Is the inspection result normal?

YES >> INSPECTION END

NO >> Repair the ICC sensor ground circuit.

A
B
C
D
E
F
G
H
I
J
K
L
M
N
P

CCS

INTELLIGENT CRUISE CONTROL SYSTEM SYMPTOMS

< SYMPTOM DIAGNOSIS >

[ICC]

SYMPTOM DIAGNOSIS

INTELLIGENT CRUISE CONTROL SYSTEM SYMPTOMS

Symptom Table

INFOID:000000013711863

Symptoms		Reference page
Operation	MAIN switch does not turn ON	Refer to CCS-175. "Description"
	MAIN switch does not turn OFF	
	ICC system cannot be set (MAIN switch turns ON/OFF)	Refer to CCS-176. "Description"
	CANCEL switch does not function	Refer to CCS-178. "Description"
	Resume does not function	
	Set speed does not increase	
	Set distance to a vehicle ahead cannot be changed	
ICC is not canceled when the A/T selector lever is "N" position	Refer to CCS-179. "Description"	
Display/Chime	ICC system display not appear	Refer to MWI-72. "On Board Diagnosis Function"
	Chime does not sound	Refer to CCS-180. "Description"
Control	Driving force is hunting	Refer to CCS-182. "Description"
Function to detect a vehicle ahead	System frequently cannot detect a vehicle ahead	Refer to CCS-183. "Description"
	Distance to detect a vehicle ahead is short	
	System misidentifies a vehicle even though there is no vehicle ahead	<ul style="list-style-type: none"> Perform radar alignment: Refer to CCS-132. "Application Notice" Perform ICC system action test. Refer to CCS-144. "Description"
	System misidentifies a vehicle in the next lane	
	System does not detect a vehicle at all	Refer to CCS-185. "Description"

MAIN SWITCH DOES NOT TURN ON, MAIN SWITCH DOES NOT TURN OFF

< SYMPTOM DIAGNOSIS >

[ICC]

MAIN SWITCH DOES NOT TURN ON, MAIN SWITCH DOES NOT TURN OFF

Description

INFOID:0000000013711864

MAIN switch does not turn ON

- ICC system display does not appear even when MAIN switch is pressed.

MAIN switch does not turn OFF

- When ICC system display is ON, display does not turn OFF even if MAIN switch is pressed.

NOTE:

When ICC system warning illuminates, perform the self-diagnosis of ICC system, and then repair or replace the malfunctioning parts.

Diagnosis Procedure

INFOID:0000000013711865

1.MAIN SWITCH INSPECTION

1. Start the engine.
2. Check that "MAIN SW" and "CRUISE LAMP" operate normally in "DATA MONITOR" of "ICC/ADAS" with CONSULT.

Is the inspection result normal?

YES >> GO TO 2.

NO >> GO TO 4.

2.CHECK COMBINATION METER

Check that "CRUISE IND" operates normally in "DATA MONITOR" of "METER/M&A".

Is the inspection result normal?

YES >> GO TO 3.

NO >> GO TO 4.

3.PERFORM SELF-DIAGNOSIS OF COMBINATION METER

1. Perform "Self Diagnostic Result" of "METER/M&A".
2. Check if DTC is detected. Refer to [MWI-91, "DTC Index"](#).

Is any DTC detected?

YES >> Repair or replace malfunctioning parts.

NO >> GO TO 4.

4.PERFORM SELF-DIAGNOSIS RESULTS OF ICC SYSTEM

1. Perform "All DTC Reading".
2. Check if the "U1000" is detected in self-diagnosis results of "ICC/ADAS".

Is "U1000" detected?

YES >> GO TO 5.

NO >> GO TO 6.

5.CAN COMMUNICATIONS INSPECTION

Check the CAN communication and repair or replace malfunctioning parts. Refer to [CCS-171, "DTC Description"](#).

>> INSPECTION END

6.CHECK ICC STEERING SWITCH

Check the ICC steering switch. Refer to [DAS-151, "ADAS CONTROL UNIT : Diagnosis Procedure \(2.0 TURBO GASOLINE ENGINE\)"](#) (2.0L turbo gasoline engine) or [DAS-150, "ADAS CONTROL UNIT : Diagnosis Procedure \(VR30DDTT\)"](#) (VR30DDTT).

>> INSPECTION END

A
B
C
D
E
F
G
H
I
J
K
L
M
N

CCS

P

ICC SYSTEM CANNOT BE SET (MAIN SWITCH TURNS ON/OFF)

< SYMPTOM DIAGNOSIS >

[ICC]

ICC SYSTEM CANNOT BE SET (MAIN SWITCH TURNS ON/OFF)

Description

INFOID:000000013711866

The MAIN switch can be turned ON/OFF, but the ICC system cannot be set even if the SET/COAST switch is pressed.

NOTE:

The system cannot be set in the following case.

- When the vehicle ahead is not detected below the speed of 32 km/h (20 MPH).
- When the selector lever is not in the “D” position or manual mode.
- When the brake pedal is depressed.
- When the VDC is turned OFF.
- When ABS or VDC (including the TCS) operates.
- When a wheel slips.
- When ABS warning lamp is ON.
- When drive mode select switch is in SNOW position.
- When the radar is temporarily interrupted.

Diagnosis Procedure

INFOID:000000013711867

1. CHECK CAUSE OF AUTOMATIC CANCELLATION

Check if there is the cancellation cause in the “CAUSE OF AUTO-CANCEL” on “WORK SUPPORT” of “ICC/ADAS” with CONSULT.

Is it displayed?

Not displayed >> GO TO 2.

“OPE SW VOLT CIRC” >> Refer to [DAS-149, "ADAS CONTROL UNIT : DTC Description"](#).

“VHCL SPD UNMATCH” >> Refer to [DAS-136, "ADAS CONTROL UNIT : DTC Description"](#).

“IGN LOW VOLT” >> Refer to [CCS-151, "DTC Description"](#).

“ECM CIRCUIT” >> Refer to [DAS-166, "ADAS CONTROL UNIT : DTC Description"](#).

“CAN COMM ERROR” >> Refer to [DAS-211, "ADAS CONTROL UNIT : DTC Description"](#).

“ICC SENSOR CAN COMM ERR” >> Refer to [DAS-211, "ADAS CONTROL UNIT : DTC Description"](#).

“ABS/TCS/VDC CIRC” >> Refer to [DAS-138, "ADAS CONTROL UNIT : DTC Description"](#).

“ECD CIRCUIT” >> Refer to [DAS-173, "ADAS CONTROL UNIT : DTC Description"](#).

2. PERFORM THE SELF-DIAGNOSIS

1. Perform “All DTC Reading”.

2. Check if any DTC is detected in “Self Diagnostic Result” of “ICC/ADAS” or “LASER/RADAR”. Refer to [DAS-67, "DTC Index"](#) (ICC/ADAS) or [CCS-88, "DTC Index"](#) (LASER/RADAR).

Is any DTC detected?

YES >> GO TO 3.

NO >> GO TO 4.

3. REPAIR OR REPLACE MALFUNCTIONING PARTS

Repair or replace malfunctioning parts identified by the self-diagnosis result.

>> GO TO 6.

4. CHECK EACH SWITCH AND VEHICLE SPEED SIGNAL

1. Start the engine.

2. Check that the following items operate normally in “DATA MONITOR” of “ICC/ADAS”.

- “VHCL SPEED SE”
- “D RANGE SW”
- “SET/COAST SW”
- “BRAKE SW”
- “PKB SW”

Is there a malfunctioning item?

All items are normal >> GO TO 5.

“VHCL SPEED SE” >> Refer to [DAS-136, "ADAS CONTROL UNIT : DTC Description"](#).

“D RANGE SW” >> Refer to [CCS-179, "Diagnosis Procedure"](#).

ICC SYSTEM CANNOT BE SET (MAIN SWITCH TURNS ON/OFF)

< SYMPTOM DIAGNOSIS >

[ICC]

“SET/COAST SW”>>Refer to [DAS-149. "ADAS CONTROL UNIT : DTC Description"](#).

“BRAKE SW”>>Refer to [DAS-140. "ADAS CONTROL UNIT : DTC Description"](#).

“PKB SW”>>Refer to [WCS-62. "Diagnosis Procedure"](#).

A

5.REPLACE ADAS CONTROL UNIT

Replace the ADAS control unit. Refer to [DAS-352. "Removal and Installation"](#).

B

>> GO TO 6.

6.CHECK ICC SYSTEM

C

1. Erase the self-diagnosis results, and then perform “All DTC Reading” again after performing the action test. (Refer to [CCS-144. "Description"](#) for action test.)
2. Check that the ICC system is normal.

D

>> INSPECTION END

E

F

G

H

I

J

K

L

M

N

CCS

P

ICC STEERING SWITCH (OTHER THAN MAIN SWITCH) DOES NOT FUNCTION

< SYMPTOM DIAGNOSIS >

[ICC]

ICC STEERING SWITCH (OTHER THAN MAIN SWITCH) DOES NOT FUNCTION

Description

INFOID:000000013711868

ICC MAIN switch can be turned ON/OFF, but the operation of RESUME/ACCELERATE switch, CANCEL switch, and DISTANCE switch cannot be performed during ICC system operation.

NOTE:

Resume is not accepted when the following condition is met.

- When the MAIN switch is turned OFF once.

The set distance change is not accepted when any of the following condition is met.

- When the DCA system is turned ON.

Diagnosis Procedure

INFOID:000000013711869

1. CHECK EACH SWITCH

1. Start the engine.
2. Check that each switch operates normally on "DATA MONITOR" of "ICC/ADAS" with CONSULT.
 - "RESUME/ACC SW"
 - "CANCEL SW"
 - "DISTANCE SW"

Is the inspection result normal?

YES >> GO TO 5.

NO >> GO TO 2.

2. PERFORM ALL OF THE SELF-DIAGNOSIS ITEMS

1. Perform "All DTC Reading".
2. Check if the "U1000" is detected in "Self Diagnostic Result" of "ICC/ADAS".

Is "U1000" detected?

YES >> GO TO 3.

NO >> GO TO 4.

3. CAN COMMUNICATIONS INSPECTION

Check the CAN communication and repair or replace malfunctioning parts. Refer to [CCS-171. "DTC Description"](#).

>> INSPECTION END

4. CHECK ICC STEERING SWITCH

Check the ICC steering switch. Refer to [DAS-152. "ADAS CONTROL UNIT : Component Inspection \(With ICC\)"](#).

>> GO TO 6.

5. REPLACE ADAS CONTROL UNIT

Replace the ADAS control unit. Refer to [DAS-352. "Removal and Installation"](#).

>> GO TO 6.

6. CHECK ICC SYSTEM

1. Erase the self-diagnosis results, and then perform "All DTC Reading" again after performing the action test. (Refer to [CCS-144. "Description"](#) for action test.)
2. Check that the ICC system is normal.

>> INSPECTION END

ICC SYSTEM DOES NOT CANCEL WHEN A/T SELECTOR LEVER SETS ON "N"

Description

INFOID:0000000013711870

The ICC system is not canceled even when the A/T selector lever is shifted to the N position while the ICC system is active.

Diagnosis Procedure

INFOID:0000000013711871

1. CHECK D RANGE SWITCH

Check if "D RANGE SW" operates normally in "DATA MONITOR" of "ICC/ADAS" with CONSULT.

Is the inspection result normal?

- YES >> GO TO 6.
- NO >> GO TO 2.

2. PERFORM ALL SELF-DIAGNOSIS ITEMS

1. Perform "All DTC Reading".
2. Check if the "U1000" is detected in "self-diagnosis results" of "ICC/ADAS".

Is "U1000" detected?

- YES >> GO TO 3.
- NO >> GO TO 4.

3. CAN COMMUNICATIONS INSPECTION

Check the CAN communication and repair or replace malfunctioning parts. Refer to [CCS-171, "DTC Description"](#).

>> INSPECTION END

4. CHECK POSITION SWITCH

Check if "SLCT LVR POSI" operates normally in "DATA MONITOR" of "TRANSMISSION".

Is the inspection result normal?

- YES >> GO TO 6.
- NO >> GO TO 5.

5. PERFORM TCM SELF-DIAGNOSIS

1. Perform the "Self Diagnostic Result" of "TRANSMISSION".
2. Repair or replace malfunctioning parts. Refer to [TM-102, "2.0L TURBO GASOLINE ENGINE : DTC Index"](#) (2.0L turbo gasoline engine) or [TM-111, "VR30DDTT : DTC Index"](#) (VR30DDTT).

>> GO TO 7.

6. REPLACE ADAS CONTROL UNIT

Replace the ADAS control unit. Refer to [DAS-352, "Removal and Installation"](#).

>> GO TO 7.

7. CHECK ICC SYSTEM

1. Erase the self-diagnosis results, and then perform "All DTC Reading" again after performing the action test. (Refer to [CCS-144, "Description"](#) for action test.)
2. Check that the ICC system is normal.

>> INSPECTION END

CHIME DOES NOT SOUND

< SYMPTOM DIAGNOSIS >

[ICC]

CHIME DOES NOT SOUND

Description

INFOID:000000013711872

Symptom check: In the following conditions, the warning chime may not sound even if the vehicle distance is short.

- When the vehicles are traveling at the same speed and the distance between vehicles is not changing.
- When the vehicle ahead is traveling faster and the distance between vehicles is increasing.
- The warning chime will not sound when the accelerator pedal is depressed, overriding the system.
- The warning chime will not sound when own vehicle approaches vehicles that are parked or moving slowly.
- The warning chime does not sound when the system does not detect any vehicle ahead. (Diagnose the conditions under which the system is detecting the vehicle ahead and when the system is malfunctioning. If there is any malfunction in detecting the vehicle ahead, check the system following the [CCS-183, "Description"](#).)

Diagnosis Procedure

INFOID:000000013711873

1.PERFORM ACTIVE TEST

Check if the warning chime sounds on the active test item "ICC BUZZER" of "ICC/ADAS" with CONSULT.

Does the warning chime sound?

- YES >> GO TO 2.
- NO >> GO TO 3.

2.CHECK THE MALFUNCTION SYMPTOM DURING WARNING CHIME OPERATION

Understand the vehicle ahead detecting condition when the malfunction occurred. If the warning chime should have sounded, replace the ADAS control unit. Refer to [DAS-352, "Removal and Installation"](#).

>> GO TO 8.

3.CHECK DRIVER ASSISTANCE BUZZER

Check if the warning chime sounds on the active test item ADAS buzzer 2 of "ICC/ADAS 2" with CONSULT.

Is the inspection result normal?

- YES >> GO TO 4.
- NO >> GO TO 5.

4.PERFORM THE SELF-DIAGNOSIS OF ADAS CONTROL UNIT

1. Perform "All DTC Reading" with CONSULT.
2. Check if the any DTC is detected in self-diagnosis results of "ICC/ADAS".

Is any DTC detected?

- YES >> GO TO 6.
- NO >> GO TO 5.

5.PERFORM THE SELF-DIAGNOSIS OF ADAS CONTROL UNIT 2

1. Perform "All DTC Reading" with CONSULT.
2. Check if the "any DTC" is detected in self-diagnosis results of "ICC/ADAS 2".

Is "any DTC" detected?

- YES >> GO TO 6.
- NO >> GO TO 7.

6.REPAIR OR REPLACE MALFUNCTIONING PARTS

Repair or replace malfunctioning parts.

>> GO TO 8.

7.REPLACE ADAS CONTROL UNIT

Replace the ADAS control unit. Refer to [DAS-352, "Removal and Installation"](#).

CHIME DOES NOT SOUND

< SYMPTOM DIAGNOSIS >

[ICC]

>> GO TO 8.

8. CHECK ICC SYSTEM

1. Erase the self-diagnosis results, and then perform "All DTC Reading" again after performing the action test. (Refer to [CCS-144. "Description"](#) for action test.)
2. Check that the ICC system is normal.

>> INSPECTION END

A
B
C
D
E
F
G
H
I
J
K
L
M
N
P

CCS

DRIVING FORCE IS HUNTING

Description

INFOID:000000013711874

The vehicle causes hunting when the ICC system is active.

Diagnosis Procedure

INFOID:000000013711875

1.PERFORM SELF-DIAGNOSIS OF ECM

1. Perform "All DTC Reading" with CONSULT.
2. Check if the DTC is detected in self-diagnosis results of "ENGINE".
 - 2.0L turbo gasoline engine: Refer to [EC4-145. "DTC Index"](#).
 - VR30DDTT
 - Turbo high pressure model: Refer to [EC6-157. "TURBO HIGH PRESSURE MODEL : DTC Index"](#).
 - Turbo low pressure model: Refer to [EC6-199. "TURBO LOW PRESSURE MODEL : DTC Index"](#).

Is any DTC detected?

- YES >> GO TO 3.
NO >> GO TO 2.

2.CHECK ICC SENSOR

1. Check the vehicle driving conditions. Refer to [CCS-183. "Description"](#).
2. Check the ICC sensor for contamination, foreign materials, or cracks. Refer to [CCS-183. "Diagnosis Procedure"](#).

>> INSPECTION END

3.REPAIR OR REPLACE MALFUNCTIONING PARTS

Repair or replace malfunctioning parts identified by the self-diagnosis result.

>> GO TO 4.

4.CHECK ICC SYSTEM

1. Erase the self-diagnosis results, and then perform "All DTC Reading" again after performing the action test. (Refer to [CCS-144. "Description"](#) for action test.)
2. Check that the ICC system is normal.

>> INSPECTION END

FREQUENTLY CANNOT DETECT THE VEHICLE AHEAD / DETECTION ZONE IS SHORT

< SYMPTOM DIAGNOSIS >

[ICC]

FREQUENTLY CANNOT DETECT THE VEHICLE AHEAD / DETECTION ZONE IS SHORT

Description

INFOID:0000000013711876

The detection function may become unstable in the following cases.

- When radar reflections from the vehicle ahead is interrupted.
- When driving a road with extremely sharp corners.
- When the sensor cannot detect a vehicle ahead while the vehicle ahead passes a hill or valley.

Diagnosis Procedure

INFOID:0000000013711877

1.VISUAL CHECK (1)

Check the contamination and foreign matter on the ICC sensor area of the front bumper.

Do foreign matter adhere?

YES >> GO TO 3.

NO >> GO TO 2.

2.VISUAL CHECK (2)

1. Remove the front bumper. Refer to [EXT-23, "Removal and Installation"](#).

2. Check ICC sensor for contamination and foreign matter.

Do foreign matter adhere?

YES >> GO TO 3.

NO >> GO TO 4.

3.WIPE OUT DIRT AND FOREIGN MATERIALS

Wipe out the contamination and foreign matter in the area around the ICC sensor.

>> GO TO 8.

4.VISUAL CHECK (3)

Check ICC sensor for cracks and scratches.

Are there any cracks or scratches?

YES >> GO TO 6.

NO >> GO TO 5.

5.PERFORM RADAR ALIGNMENT

1. Install the front bumper. Refer to [EXT-23, "Removal and Installation"](#).

2. Perform the radar alignment. Refer to [CCS-132, "Application Notice"](#).

3. Perform ICC system action test. Refer to [CCS-144, "Description"](#).

4. Check that the vehicle ahead detection performance improves.

Does it improve?

YES >> INSPECTION END

NO >> GO TO 6.

6.REPLACE ICC SENSOR

1. Replace the ICC sensor. Refer to [CCS-190, "Exploded View"](#).

2. Install the front bumper. Refer to [EXT-23, "Removal and Installation"](#).

3. Perform the radar alignment. Refer to [CCS-132, "Application Notice"](#).

4. Perform ICC system action test. Refer to [CCS-144, "Description"](#).

5. Check that the vehicle ahead detection performance improves.

Does it improve?

YES >> INSPECTION END

NO >> GO TO 7.

7.REPLACE ADAS CONTROL UNIT

Replace ADAS control unit. Refer to [DAS-352, "Removal and Installation"](#).

A
B
C
D
E
F
G
H
I
J
K
L
M
N
P

FREQUENTLY CANNOT DETECT THE VEHICLE AHEAD / DETECTION ZONE IS SHORT

< SYMPTOM DIAGNOSIS >

[ICC]

>> GO TO 8.

8. CHECK ICC SYSTEM

1. Erase the self-diagnosis results, and then perform "All DTC Reading" again after performing the action-test. (Refer to [CCS-144. "Description"](#) for action test).
2. Check that the ICC system is normal.

>> INSPECTION END

THE SYSTEM DOES NOT DETECT THE VEHICLE AHEAD AT ALL

< SYMPTOM DIAGNOSIS >

[ICC]

THE SYSTEM DOES NOT DETECT THE VEHICLE AHEAD AT ALL

Description

INFOID:0000000013711878

When ICC system is active, the ICC system does not perform any control even through there is a vehicle ahead.

Diagnosis Procedure

INFOID:0000000013711879

1. CHECK ICC SYSTEM DISPLAY ON MULTI INFORMATION DISPLAY

1. Start the self-diagnosis mode of combination meter. Refer to [MWI-72. "On Board Diagnosis Function"](#).
2. Check that the multi information display turns on normally.

Is the inspection result normal?

- YES >> GO TO 2.
NO >> Replace the combination meter.

2. VISUAL CHECK (1)

Check the contamination and foreign matter on the ICC sensor area of the front bumper.

Do foreign materials adhere?

- YES >> GO TO 4.
NO >> GO TO 3.

3. VISUAL CHECK (2)

1. Remove the front bumper. Refer to [EXT-23. "Removal and Installation"](#).
2. Check ICC sensor for contamination and foreign matter.

Do foreign matter adhere?

- YES >> GO TO 4.
NO >> GO TO 5.

4. WIPE OUT DIRT AND FOREIGN MATERIALS

Wipe out the contamination and foreign matter in the area around the ICC sensor.

>> GO TO 9.

5. VISUAL CHECK (3)

Check ICC sensor for cracks and/or scratches.

Are there cracks?

- YES >> GO TO 7.
NO >> GO TO 6.

6. PERFORM RADAR ALIGNMENT

1. Install the front bumper. Refer to [EXT-23. "Removal and Installation"](#).
2. Perform the radar alignment. Refer to [CCS-132. "Application Notice"](#).
3. Perform ICC system action test. Refer to [CCS-144. "Description"](#).
4. Check that the vehicle ahead detection performance improves.

Does it improve?

- YES >> INSPECTION END
NO >> GO TO 8.

7. REPLACE ICC SENSOR

1. Replace the ICC sensor. Refer to [CCS-190. "Exploded View"](#).
2. Install the front bumper. Refer to [EXT-23. "Removal and Installation"](#).
3. Perform the radar alignment. Refer to [CCS-132. "Application Notice"](#).
4. Perform ICC system action test. Refer to [CCS-144. "Description"](#).
5. Check that the vehicle ahead detection performance improves.

Does it improve?

- YES >> INSPECTION END

A
B
C
D
E
F
G
H
I
J
K
L
M
N
P

THE SYSTEM DOES NOT DETECT THE VEHICLE AHEAD AT ALL

< SYMPTOM DIAGNOSIS >

[ICC]

NO >> GO TO 8.

8.REPLACE ADAS CONTROL UNIT

Replace ADAS control unit. Refer to [DAS-352, "Removal and Installation"](#).

>> GO TO 9.

9.CHECK ICC SYSTEM

-
1. Erase the self-diagnosis results, and then perform "All DTC Reading" again after performing the action test. (Refer to [CCS-144, "Description"](#) for action test.)
 2. Check that the ICC system is normal.

>> INSPECTION END

NORMAL OPERATING CONDITION

Description

INFOID:0000000013711880

PRECAUTIONS FOR VEHICLE-TO-VEHICLE DISTANCE CONTROL MODE

- ICC system is only an aid to assist the driver and is not a collision warning or avoidance device. It is the driver's responsibility to stay alert, drive safely and be in control of the vehicle at all times.
- The system is primarily intended for use on straight, dry, open roads with light traffic. It is not advisable to use the system in city traffic or congested areas.
- This system will not adapt automatically to road conditions. This system should be used in evenly flowing traffic. Do not use the system on roads with sharp curves, or on icy roads, in heavy rain or in fog.
- The ICC sensor will not detect under most conditions.
 - Stationary and slow moving vehicles.
 - Pedestrians or objects in the roadway.
 - Oncoming vehicles in the some lane.
 - Motorcycles traveling offset in the travel lane.
- As there is a performance limit to the distance control function, never rely solely on the ICC system. This system does not correct careless, inattentive or absent-minded driving, or overcome poor visibility in rain, fog, or other bad weather. Decelerate the vehicle speed by depressing the brake pedal, depending on the distance to the vehicle ahead and the surrounding circumstances in order to maintain a safe distance between vehicles.
- If the vehicle ahead comes to a stop, the vehicle decelerates to a standstill within the limitations of the system. The system will cancel once it judges that the vehicle has come to a standstill and sound a warning chime. To prevent the vehicle from moving, the driver must depress the brake pedal.
- The system may not detect the vehicle in front of the driver in certain road or weather conditions. To avoid accidents, never use the ICC system under the following conditions:
 - On roads where the traffic is heavy or there are sharp curves.
 - On slippery road surfaces such as on ice or snow, etc.
 - During bad weather (rain, fog, snow, etc.)
 - When rain, snow or dirt adhere to the system sensor.
 - On steep downhill roads (the vehicle may go beyond the set vehicle speed and frequent braking may result in overheating the brakes).
 - On repeated uphill and downhill roads.
 - When traffic conditions make it difficult to keep a proper distance between vehicles because of frequent acceleration or deceleration.
- In some road or traffic conditions, a vehicle or object can unexpectedly come into the sensor detection zone and cause automatic braking. The driver may need to control the distance from other vehicles using the accelerator pedal. Always stay alert and avoid using the ICC system when it is not recommended in this section.
- The vehicle-to-vehicle distance control mode uses a sensor located behind the lower grille of the front bumper to detect vehicles traveling ahead. The sensor generally detects the signals returned from the vehicle ahead. Therefore, if the sensor cannot detect the reflection from the vehicle ahead, the ICC system may not maintain the selected distance.
- The following are some conditions in which the sensor cannot detect the signals:
 - When the snow or road spray from traveling vehicles reduces the sensor's visibility.
 - When excessively heavy baggage is loaded in the rear seat or the trunk room of own vehicle.
- The ICC system is designed to automatically check the sensor's operation within the limitation of the system. When the sensor area of the front bumper is covered with dirt or is obstructed, the system will automatically be canceled. If the sensor is covered with ice, a transparent or translucent vinyl bag, etc., the ICC system may not detect them. In these instances, the vehicle-to-vehicle distance control mode may not cancel and may not be able to maintain the selected following distance from the vehicle ahead. Be sure to check and clean the sensor regularly.
- The ICC system does not control vehicle speed or warn the driver when own vehicle approaches stationary and slow moving vehicles. The driver must pay attention to vehicle operation to maintain proper distance from vehicles ahead when approaching toll gates or traffic congestion.

A
B
C
D
E
F
G
H
I
J
K
L
M
N
P

CCS

NORMAL OPERATING CONDITION

[ICC]

< SYMPTOM DIAGNOSIS >

- The detection zone of the ICC sensor is limited. A vehicle ahead must be in the detection zone for the vehicle-to-vehicle distance detection mode to maintain the selected distance from the vehicle ahead. A vehicle ahead may move outside of the detection zone due to its position within the same lane of travel. Motorcycles may not be detected in the same lane ahead if they are traveling offset from the center line of the lane. A vehicle that is entering the lane ahead may not be detected until the vehicle has completely moved into the lane. If this occurs, the ICC system may warn the driver by blinking the system indicator and sounding the chime. The driver may have to manually control the proper distance away from vehicle traveling ahead.

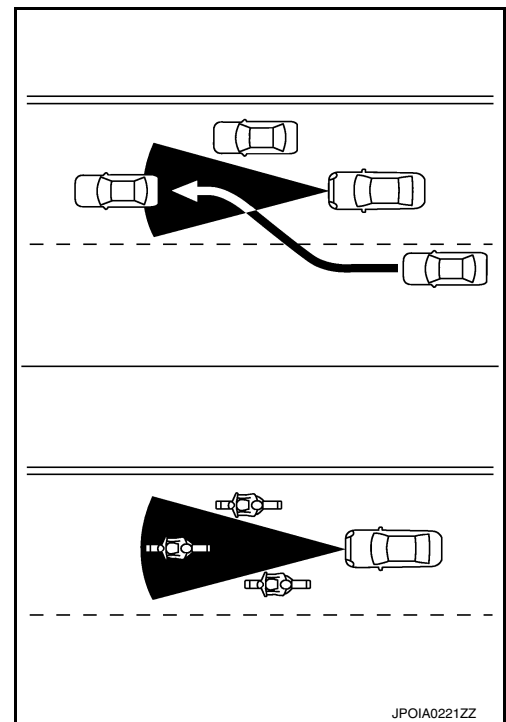

- When driving on some roads, such as winding, hilly, curved, narrow roads, or roads which are under construction, the ICC sensor may detect vehicles in a different lane, or may temporarily not detect a vehicle traveling ahead. This may cause the ICC system to decelerate or accelerate the vehicle. The detection of vehicles may also be affected by vehicle operation (steering maneuver or traveling position in the lane, etc.) or vehicle condition. If this occurs, the ICC system may warn the driver by blinking the system indicator and sounding the chime unexpectedly. The driver will have to manually control the proper distance away from the vehicle traveling ahead.

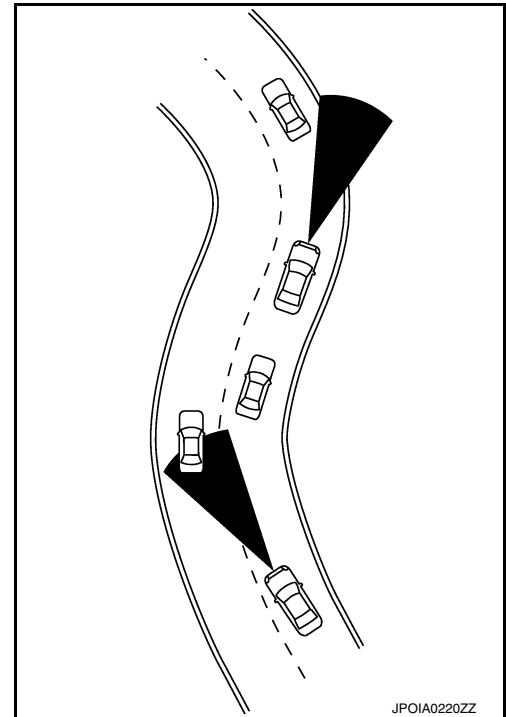

- When driving on the freeway at a set speed and approaching a slower traveling vehicle ahead, the ICC will adjust the speed to maintain the distance, selected by the driver, from the vehicle ahead. If the vehicle ahead changes lanes or exits the freeway, the ICC system will accelerate and maintain the speed up to the set speed. Pay attention to the driving operation to maintain control of the vehicle as it accelerates to the set speed. The vehicle may not maintain the set speed on winding or hilly roads. If this occurs, the driver will have to manually control the vehicle speed.

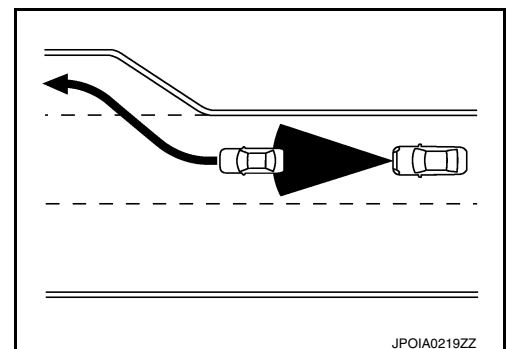

NORMAL OPERATING CONDITION

< SYMPTOM DIAGNOSIS >

[ICC]

- Normally when controlling the distance to a vehicle ahead, this system automatically accelerates or decelerates own vehicle according to the speed of the vehicle ahead. Depress the accelerator to properly accelerate own vehicle when acceleration is required for a lane change. Depress the brake pedal when deceleration is required to maintain a safe distance to the vehicle ahead due to its sudden braking or if a vehicle cuts in. Always stay alert when using the ICC system.

PRECAUTIONS FOR CONVENTIONAL (FIXED SPEED) CRUISE CONTROL MODE

- In the conventional (fixed speed) cruise control mode, a warning chime does not sound to warn the driver if own vehicle is too close to the vehicle ahead, as neither the presence of the vehicle ahead nor the vehicle-to-vehicle distance is detected.
- Pay special attention to the distance between own vehicle and the vehicle ahead or a collision could occur.
- Always confirm the setting in the ICC system display.
- Do not use the conventional (fixed speed) cruise control mode when driving under the following conditions:
 - When it is not possible to keep the vehicle at a set speed.
 - In heavy traffic or in traffic that varies in speed.
 - On winding or hilly roads.
 - On slippery roads (rain, snow, ice, etc.).
 - In very windy areas.
- Doing so could cause a loss of vehicle control and result in an accident.
- To avoid accidentally engaging cruise control, make sure to turn the MAIN switch off when not using the ICC system.

A
B
C
D
E
F
G
H
I
J
K
L
M
N
P

CCS

ICC SENSOR

< REMOVAL AND INSTALLATION >

[ICC]

REMOVAL AND INSTALLATION

ICC SENSOR

Exploded View

INFOID:000000013711881

CAUTION:

Always perform the laser beam aiming adjustment and check the operation after the replacement, removal and installation of ICC sensor.

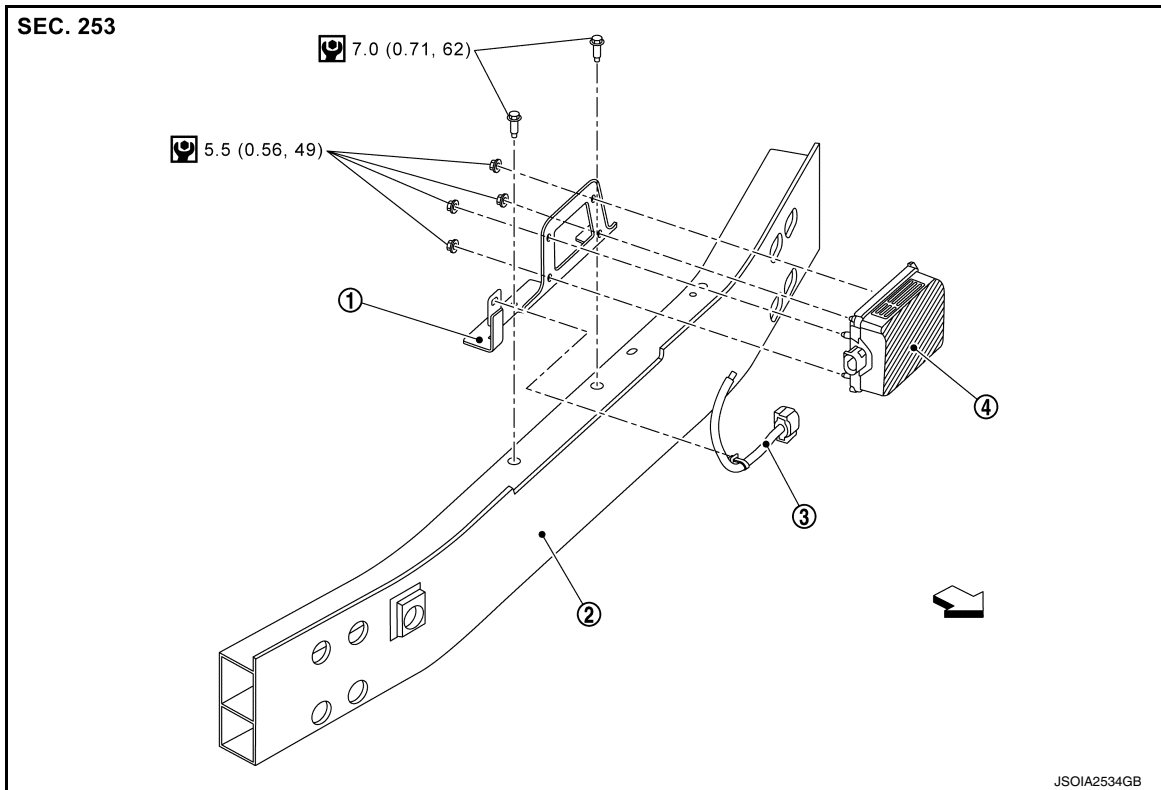

- ① Bracket
 - ② Front bumper reinforcement
 - ③ ICC sensor harness connector
 - ④ ICC sensor
-  : N·m (kg-m, in-lb)

Removal and Installation

INFOID:000000013711882

REMOVAL

1. Remove front bumper fascia. Refer to [EXT-23. "Removal and Installation"](#).
2. Disconnect ICC sensor connector.
3. Remove mounting bolts (A) of bracket to remove ICC sensor with bracket.

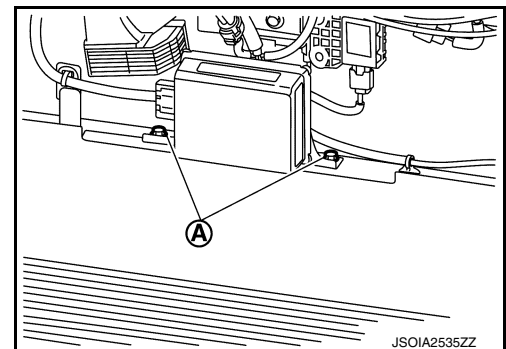

ICC SENSOR

< REMOVAL AND INSTALLATION >

[ICC]

4. Remove mounting nuts (A) of ICC sensor.

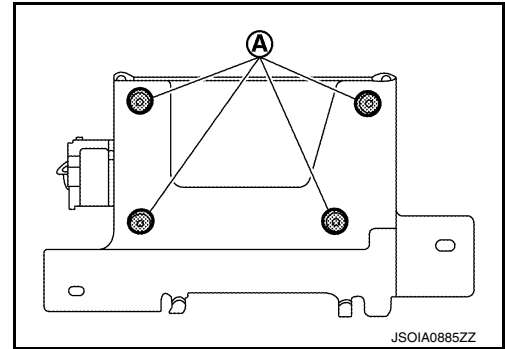

5. Remove ICC sensor.

INSTALLATION

Install in the reverse order of removal.

CAUTION:

Always perform the radar alignment and check the operation after the replacement, removal, and installation of ICC sensor. Refer to [CCS-131, "Description"](#).

A
B
C
D
E
F
G
H
I
J
K
L
M
N
P

CCS

ICC STEERING SWITCH

< REMOVAL AND INSTALLATION >

[ICC]

ICC STEERING SWITCH

Exploded View

INFOID:000000013711883

ICC steering switch is integrated in the steering switch.

Refer to [ST-133. "Removal and Installation"](#).

NOTE:

Always remove ICC steering switch together with steering wheel.

HOW TO USE THIS MANUAL

HOW TO USE THIS SECTION

Information

INFOID:0000000013711884

For ICC system, refer to [CCS-15, "System Description"](#).

FOR 2.0L TURBO GASOLINE ENGINE MODELS

This section includes information of the system except for 2.0l turbo gasoline engine models.

FOR VR30DDTT ENGINE MODELS

Automatic Speed Control Device (ASCD) system for VR30DDTT engine models is controlled by ECM.

Regarding the information for ASCD system for VR30DDTT engine models, refer to [EC6-74, "AUTOMATIC SPEED CONTROL DEVICE \(ASCD\) : System Description"](#).

A
B
C
D
E
F
G
H
I
J
K
L
M
N
P

CCS

< PRECAUTION >

PRECAUTION

PRECAUTIONS

Precautions for Removing Battery Terminal

INFOID:000000013952962

When disconnecting the battery terminal, pay attention to the following.

- Always use a 12V battery as power source.
- Never disconnect battery terminal while engine is running.
- When removing the 12V battery terminal, turn OFF the ignition switch and wait at least 30 seconds.
- For vehicles with the engine listed below, remove the battery terminal after a lapse of the specified time:

BR08DE	: 4 minutes	YD25DDTi	: 2 minutes
D4D engine	: 20 minutes	YS23DDT	: 4 minutes
HRA2DDT	: 12 minutes	YS23DDTT	: 4 minutes
K9K engine	: 4 minutes	ZD30DDTi	: 60 seconds
M9R engine	: 4 minutes	ZD30DDTT	: 60 seconds
R9M engine	: 4 minutes		
V9X engine	: 4 minutes		

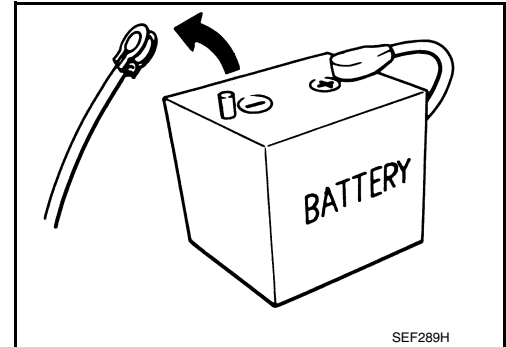

NOTE:

ECU may be active for several tens of seconds after the ignition switch is turned OFF. If the battery terminal is removed before ECU stops, then a DTC detection error or ECU data corruption may occur.

- After high-load driving, if the vehicle is equipped with the V9X engine, turn the ignition switch OFF and wait for at least 15 minutes to remove the battery terminal.

NOTE:

- Turbocharger cooling pump may operate in a few minutes after the ignition switch is turned OFF.
- Example of high-load driving
 - Driving for 30 minutes or more at 140 km/h (86 MPH) or more.
 - Driving for 30 minutes or more on a steep slope.
- For vehicles with the 2-batteries, be sure to connect the main battery and the sub battery before turning ON the ignition switch.

NOTE:

If the ignition switch is turned ON with any one of the terminals of main battery and sub battery disconnected, then DTC may be detected.

- After installing the 12V battery, always check "Self Diagnosis Result" of all ECUs and erase DTC.

NOTE:

The removal of 12V battery may cause a DTC detection error.

Precaution for Battery Service

INFOID:000000014277119

Before disconnecting the battery, lower both the driver and passenger windows. This will prevent any interference between the window edge and the vehicle when the door is opened/closed. During normal operation, the window slightly raises and lowers automatically to prevent any window to vehicle interference. The automatic window function will not work with the battery disconnected.

SYSTEM DESCRIPTION

COMPONENT PARTS

Component Parts Location

INFOID:000000013711886

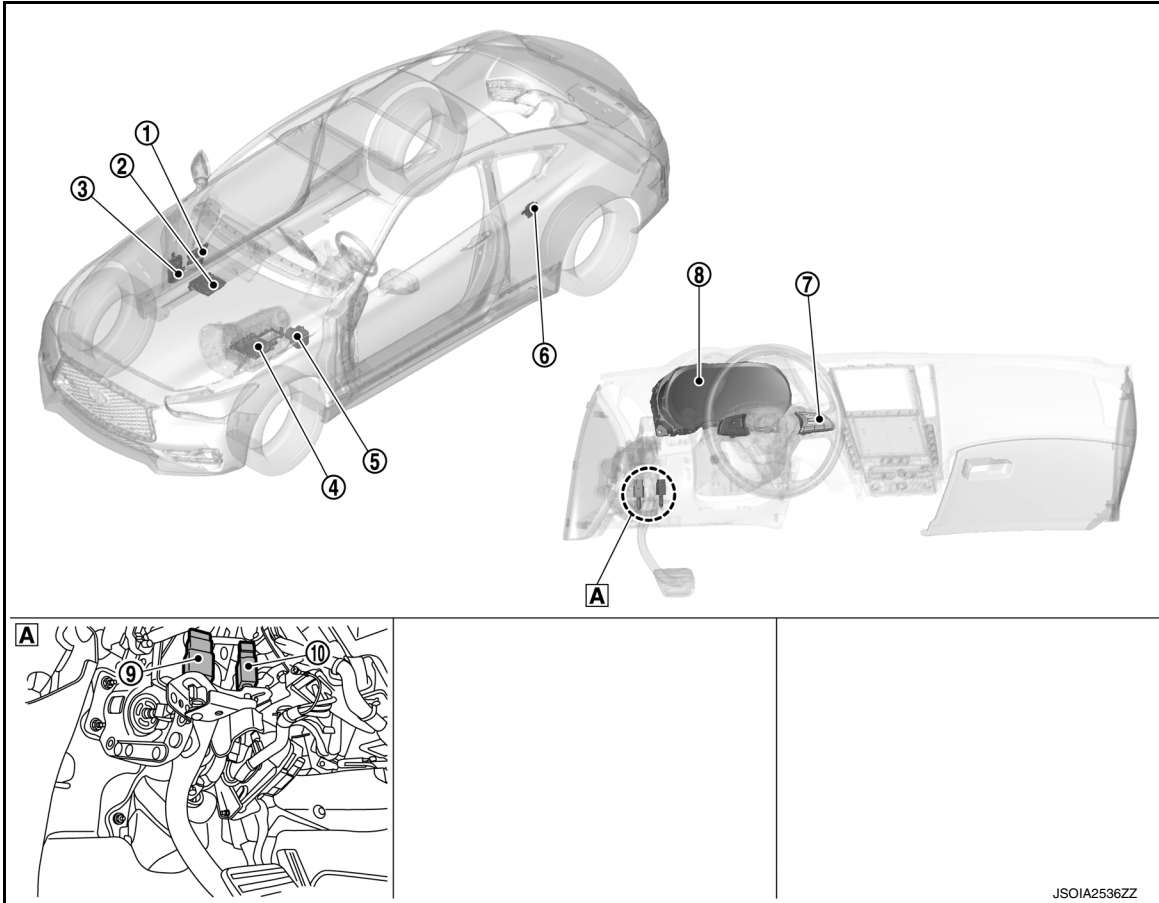

A Upper side of brake pedal

×: Applicable

No.	Component	Description
①	ADAS control unit	<ul style="list-style-type: none"> Refer to CCS-196. "ADAS Control Unit" Refer to DAS-18. "Component Parts Location" for detailed installation location
②	ECM	<ul style="list-style-type: none"> ECM transmits the accelerator pedal position signal, etc. to ADAS control unit via CAN communication ECM controls the fuel injection quantity based on the engine torque demand received from the ADAS control unit via CAN communication Refer to EC4-25. "ENGINE CONTROL SYSTEM : Component Parts Location" for detailed installation location
③	BCM	<ul style="list-style-type: none"> BCM transmits the stop lamp switch signal to ADAS control unit via CAN communication Refer to BCS-5. "BODY CONTROL SYSTEM : Component Parts Location" for detailed installation location
④	EMCM	<ul style="list-style-type: none"> EMCM transmits the brake pedal position switch signal to ADAS control unit via CAN communication EMCM transmits the brake pedal position switch signal, stop lamp switch signal to ECM control unit via CAN communication Refer to EC4-25. "ENGINE CONTROL SYSTEM : Component Parts Location" for detailed installation location

A
B
C
D
E
F
G
H
I
J
K
L
M
N
P

CCS

COMPONENT PARTS

< SYSTEM DESCRIPTION >

[ASCD]

No.	Component	Description
⑤	TCM	<ul style="list-style-type: none"> TCM transmits the signal related to A/T control to ADAS control unit via ECM Refer to TM-14, "A/T CONTROL SYSTEM : Component Parts Location" for detailed installation location
⑥	ABS actuator and electric unit (control unit)	<ul style="list-style-type: none"> ABS actuator and electric unit (control unit) transmits the vehicle speed signal (wheel speed), stop lamp switch signal and VDC/TCS/ABS system operation condition to ADAS control unit via CAN communication Refer to BRC-11, "Component Parts Location" for detailed installation location
⑦	Chassis control module	<ul style="list-style-type: none"> Chassis control module transmits the a drive mode signal to ADAS control unit via CAN communication Refer to DAS-666, "Component Parts Location" for detailed installation location
⑧	Steering switch	<ul style="list-style-type: none"> Description: Refer to CCS-196, "ASCD Steering Switch" Switch name and function: CCS-201, "AUTOMATIC SPEED CONTROL DEVICE (AS-CD) : Switch Name and Function"
⑨	Combination meter	<p>Performs the following operations using the signals received from the ADAS control unit via the CAN communication</p> <ul style="list-style-type: none"> Description: Refer to CCS-197, "Combination Meter" System display and warning: CCS-201, "AUTOMATIC SPEED CONTROL DEVICE (ASCD) : Menu Displayed by Pressing Each Switch"
⑩	Brake pedal position switch	Refer to CCS-196, "Brake Pedal Position Switch / Stop Lamp Switch"
⑪	Stop lamp switch	

ADAS Control Unit

INFOID:000000013965387

- ADAS control unit is installed at rear side panel LH.
- Communicates with each control unit via CAN communication/ITS communication/Chassis communication.
- ADAS control unit included gateway function, and necessary for system control signals are transmitted to each control unit between CAN communication and ITS communication by the ADAS control unit.
- ADAS control unit controls the each system, based on ITS communication signal, CAN communication signal, and chassis communication signal from each control unit.

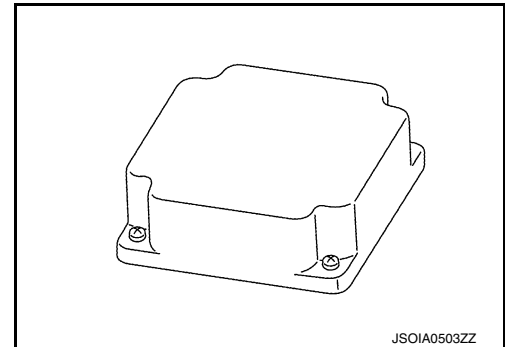

ASCD Steering Switch

INFOID:000000013711888

- ASCD steering switch is installed to the steering wheel and allows the driver to operate the ASCD/Speed limiter system by using this switch.
- ASCD steering switch allows the ON/OFF of the Automatic Speed Control Device (ASCD) and Speed limiter.
- ASCD steering switch signal is transmitted to ADAS control unit.

Brake Pedal Position Switch / Stop Lamp Switch

INFOID:000000013711889

- Brake pedal position switch is installed at the upper part of the brake pedal and detects a brake operation performed by the driver.

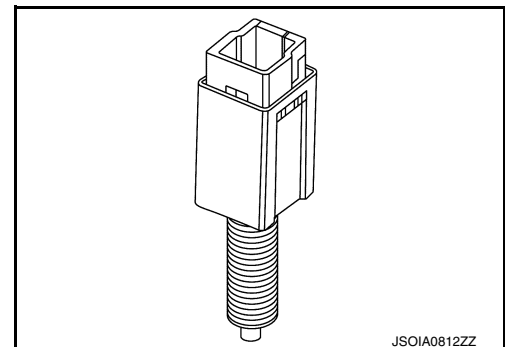

- Brake pedal position switch is turned OFF when depressing the brake pedal.

COMPONENT PARTS

[ASCD]

< SYSTEM DESCRIPTION >

- Brake pedal position switch signal is input to EMCM. Brake pedal position switch signal is transmitted from EMCM to ADAS control unit and ECM via CAN communication.
- Stop lamp switch is installed at the upper part of the brake pedal and detects a brake operation performed by the driver.
- Stop lamp switch is turned ON, when depressing the brake pedal.
- Stop lamp switch signal is input to BCM and ABS actuator and electric unit (control unit). Stop lamp switch signals are transmitted from BCM and ABS actuator and electric unit (control unit) to ADAS control unit via CAN communication.
- Stop lamp switch signal is input to EMCM. Stop lamp switch signal is transmitted from EMCM to ECM via CAN communication.

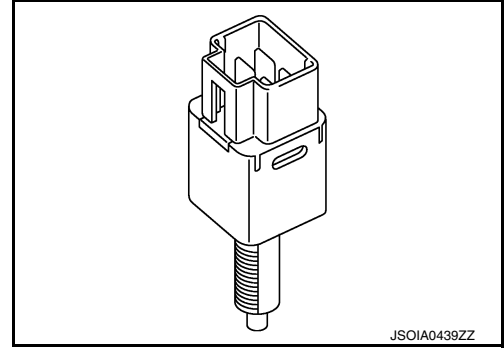

Combination Meter

- Receives meter display signal from ADAS control unit via CAN communication.
- Displays the system status according to a signal received from the ADAS control unit.
- Operates the buzzer according to the signal from the ADAS control unit.

INFOID:0000000013711890

A
B
C
D
E
F
G
H
I
J
K
L
M
N
P

CCS

SYSTEM

AUTOMATIC SPEED CONTROL DEVICE (ASCD)

AUTOMATIC SPEED CONTROL DEVICE (ASCD) : System Description

INFOID:000000013711891

SYSTEM DIAGRAM

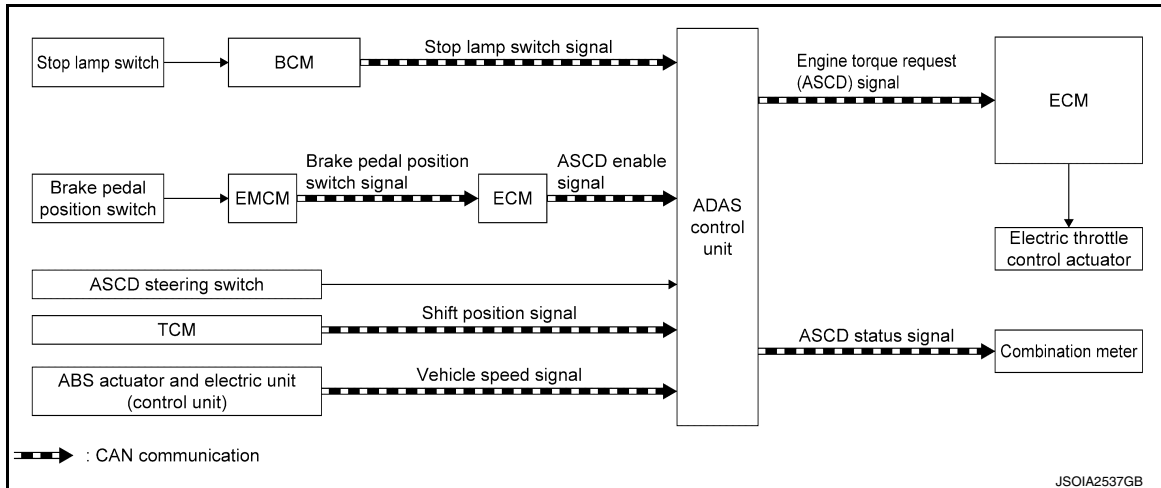

SYSTEM DESCRIPTION

Automatic Speed Control Device (ASCD) allows a driver to keep vehicle at predetermined constant speed without depressing accelerator pedal. The selectable speed ranges are as follows:

- Between approximately 40 km/h (25 MPH) and 144 km/h (90 MPH)

ECM controls fuel injectors to regulate engine speed.

Operation status of ASCD is indicated on the information display in the combination meter. If any malfunction occurs in ASCD system, it automatically deactivates control.

For the switch function, refer to [CCS-201, "AUTOMATIC SPEED CONTROL DEVICE \(ASCD\) : Switch Name and Function"](#).

For the ASCD indicator, refer to [CCS-201, "AUTOMATIC SPEED CONTROL DEVICE \(ASCD\) : Menu Displayed by Pressing Each Switch"](#).

CAUTION:

Always drive vehicle in a safe manner according to traffic conditions and obey all traffic laws.

SET OPERATION

Press MAIN switch. (The CRUISE indicator in combination meter illuminates.)

When vehicle speed reaches a desired speed, press SET/COAST switch. (Then SET lamp in combination meter illuminates.)

NOTE:

The selectable speed ranges are as follows:

- Between approximately 40 km/h (25 MPH) and 144 km/h (90 MPH)

ACCELERATE OPERATION

the switch is released or vehicle speed reaches maximum speed controlled by the system.

And then ASCD will maintain the new set speed.

COAST OPERATION

When the SET/COAST switch is pressed during cruise control driving, decrease vehicle set speed until the switch is released. And then ASCD will keep the new set speed.

CANCEL OPERATION

When any of following conditions exist, cruise operation will be canceled.

- CANCEL switch is pressed
- More than 2 switches on ASCD steering switch are pressed at the same time (Set speed will be cleared)
- Brake pedal is depressed
- Selector lever position is N, P, or R position
- Vehicle speed decreased to 13 km/h (8 MPH) lower than the set speed
- TCS system is operated

SYSTEM

< SYSTEM DESCRIPTION >

[ASCD]

RESUME OPERATION

When the RESUME/ACCELERATE switch is pressed after cancel operation other than pressing ASCD MAIN switch is performed, vehicle speed will return to last set speed. To resume vehicle set speed, vehicle condition must meet following conditions.

- Brake pedal is released
- Selector lever position is not P, R, or N.
- Vehicle speed between 40 km/h (25 MPH) and 144 km/h (90 MPH)

AUTOMATIC SPEED CONTROL DEVICE (ASCD) : Fail-safe (ADAS Control Unit)

INFOID:000000013965384

If a malfunction occurs in each system, ADAS control unit cancels each control, sounds a beep, and turns ON the warning or indicator lamp.

System	Buzzer	Warning lamp/Warning display	Description
Vehicle-to-vehicle distance control mode	High-pitched tone	ICC system warning	Cancel
Conventional (fixed speed) cruise control mode	High-pitched tone	ICC system warning	Cancel
Forward Emergency Braking (FEB)	High-pitched tone	<ul style="list-style-type: none"> • FEB warning lamp • Warning systems indicator (Forward position: Yellow) 	Cancel
Predictive Forward Collision Warning (PFCW)	High-pitched tone	Warning systems indicator (Forward position: Yellow)	Cancel
Distance Control Assist (DCA)	High-pitched tone	Warning systems indicator (Forward position: Yellow)	Cancel
Blind Spot Warning (BSW)	—	Warning systems indicator (Blind spot position: Yellow)	Cancel
Back-up Collision Intervention (BCI)	High-pitched tone	BCI system warning	Cancel

A
B
C
D
E
F
G
H
I
J
K
L
M
N

CCS

P

SYSTEM

< SYSTEM DESCRIPTION >

[ASCD]

Circuit Diagram

INFOID:000000013711892

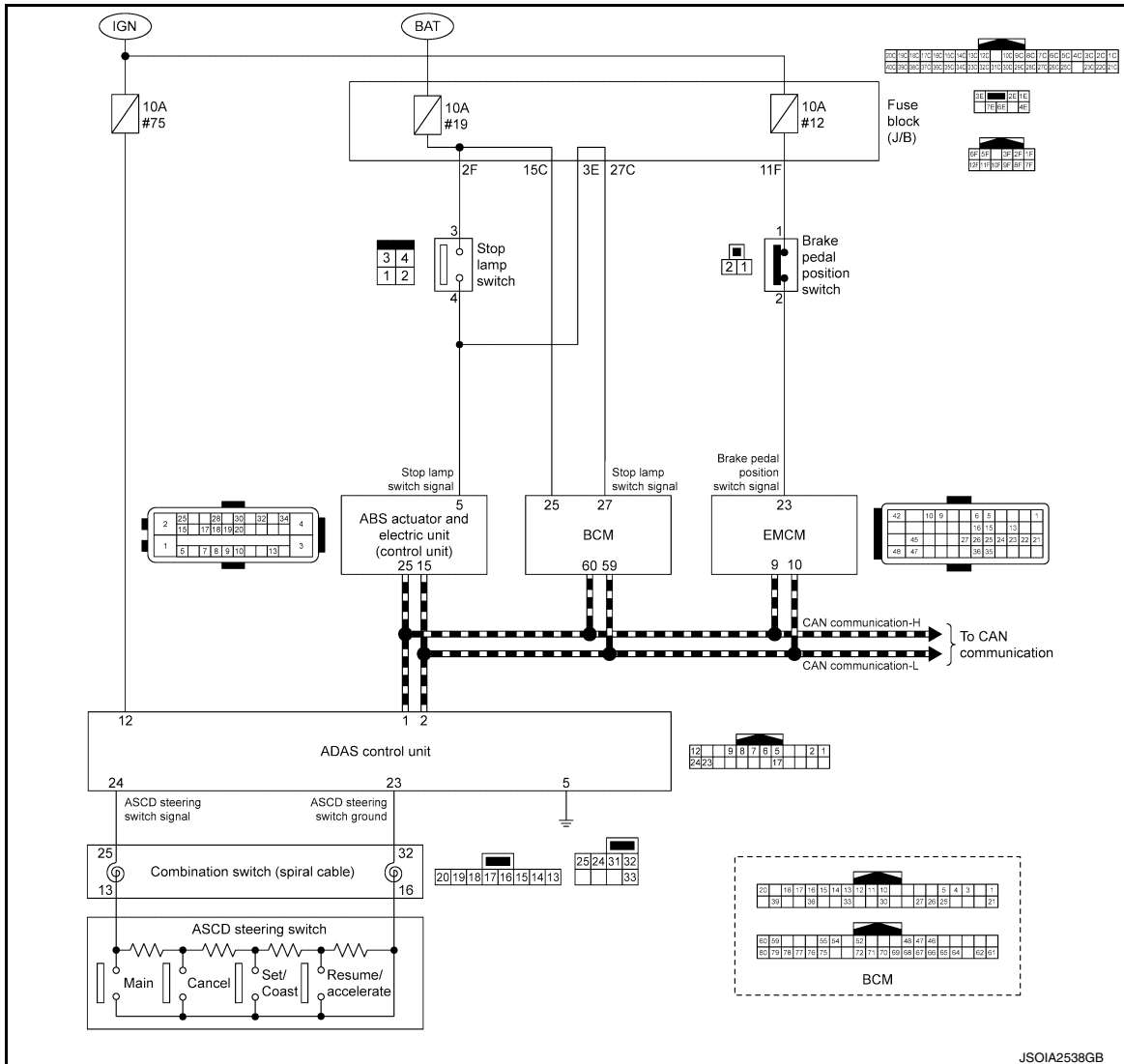

JSOIA2538GB

WARNING/INDICATOR/CHIME LIST

WARNING/INDICATOR/CHIME LIST : Indicator/Information

INFOID:000000013711893

Item	Symbol	Function
ASCD indicator	<p style="text-align: right;">JSCIA0831ZZ</p>	<p>For detail of ASCD function, refer to CCS-201, "AUTOMATIC SPEED CONTROL DEVICE (ASCD) : Menu Displayed by Pressing Each Switch".</p>

OPERATION

< SYSTEM DESCRIPTION >

[ASCD]

OPERATION

AUTOMATIC SPEED CONTROL DEVICE (ASCD)

AUTOMATIC SPEED CONTROL DEVICE (ASCD) : Switch Name and Function

INFOID:000000013711894

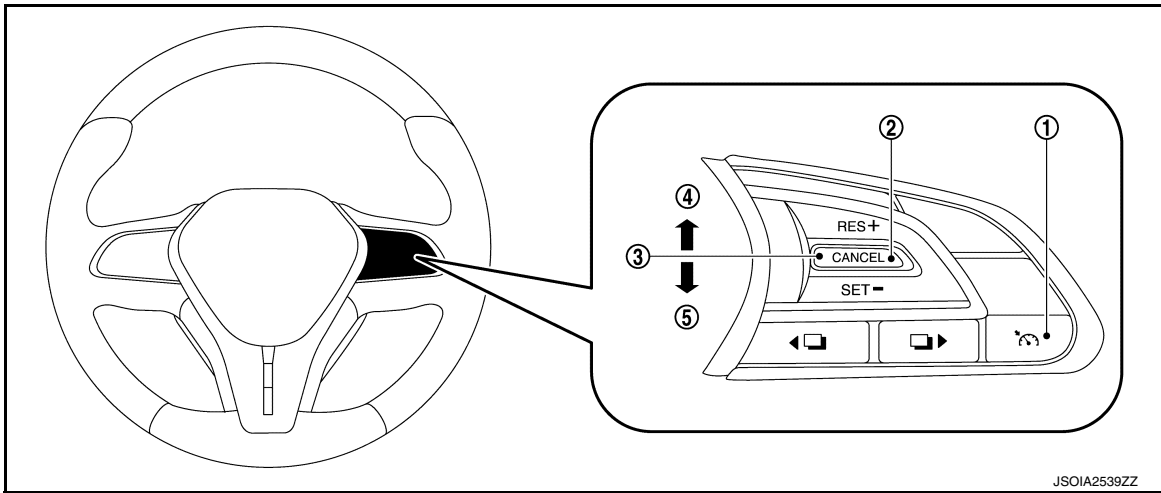

No.	Description	Function
①	ASCD MAIN switch	Master switch to activate the system
②	CANCEL switch	Deactivates system without erasing set speed
③	RESUME/ACCELERATE switch	Resumes set speed or increases speed incrementally
④	SET/COAST switch	Sets desired cruise speed or reduces speed incrementally

AUTOMATIC SPEED CONTROL DEVICE (ASCD) : Menu Displayed by Pressing Each Switch

INFOID:000000013711895

ASCD SYSTEM DISPLAY (ON THE INFORMATION DISPLAY)

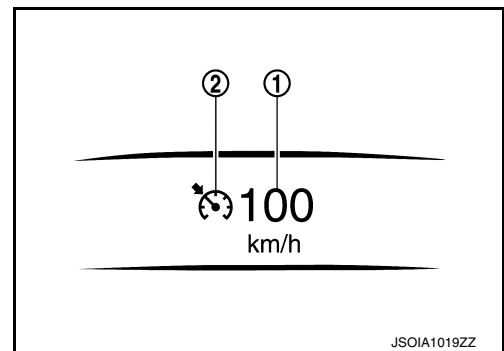

No.	Description	Function
①	Set vehicle speed indicator	Indicates the set vehicle speed
②	ASCD system warning (green: blink)	Indicates that a malfunction occurs in the ICC system
	MAIN switch indicator (white)	Indicates that the MAIN switch is ON (ASCD system ON)
	SET switch indicator (green)	Indicates that the set ASCD is controlled

SYSTEM CONTROL CONDITION DISPLAY



Push and hold the MAIN switch for longer than approximately 1.5 seconds. This mode will be in a standby state for setting.

A
B
C
D
E
F
G
H
I
J
K
L
M
N
P

OPERATION

< SYSTEM DESCRIPTION >

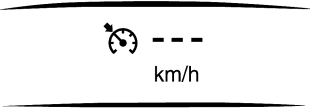
[ASCD]

Condition	Display on system display
Standby mode	 <p style="text-align: right; font-size: small;">J50IA1020ZZ</p>
Control mode	 <p style="text-align: right; font-size: small;">J50IA1021ZZ</p>

WARNING AND AUTOMATIC CANCELLATION DISPLAY

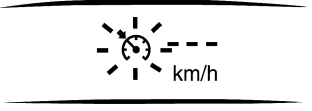
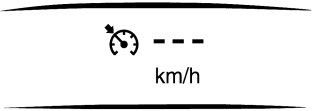
	Condition	Description	Display on system display
Warning display	When the ASCD system is malfunctioning	A chime sounds and the control is automatically canceled NOTE: Turn the engine OFF and restart engine. If there is no malfunction, it is possible to set the system	 <p style="text-align: right; font-size: small;">J50IA1022ZZ</p>
System cancel display	<ul style="list-style-type: none"> When brake pedal is depressed When pressing CANCEL switch When the vehicle slows down more than 13 km/h (8 MPH) below the set speed When the selector lever is not in the "D" position or manual mode When the parking brakes are applied When VDC (including the TCS) operates When a wheel slips 	A chime sounds and the control is automatically canceled NOTE: <ul style="list-style-type: none"> The system will be in a standby, after the control is automatically canceled A chime sounds when the control is automatically canceled, except when brake pedal is depressed or when CANCEL switch is pressed 	 <p style="text-align: right; font-size: small;">J50IA1020ZZ</p>

NOTE:
 When the ASCD system is automatically canceled, the cancellation condition can be displayed on "WORK SUPPORT" of CONSULT (ICC/ADAS).

HANDLING PRECAUTION

< SYSTEM DESCRIPTION >

[ASCD]

HANDLING PRECAUTION

Precautions for Automatic Speed Control Device (ASCD)

INFOID:000000013711896

- Always observe the posted speed limits and do not set the speed over them.
- Do not use the cruise control when driving under the following conditions. Doing so could cause a loss of vehicle control and result in an accident.
 - When it is not possible to keep the vehicle at a constant speed
 - When driving in heavy traffic
 - When driving in traffic that varies speed
 - When driving in windy areas
 - When driving on winding or hilly roads
 - When driving on slippery (rain, snow, ice, etc.) roads

A
B
C
D
E
F
G
H
I
J
K
L
M
N
P

CCS

DIAGNOSIS SYSTEM (ADAS CONTROL UNIT)

< SYSTEM DESCRIPTION >

[ASCD]

DIAGNOSIS SYSTEM (ADAS CONTROL UNIT)

CONSULT Function (ICC/ADAS)

INFOID:000000013965382

APPLICATION ITEMS

CONSULT performs the following functions via CAN communication using ADAS control unit.

Diagnosis mode	Description
Configuration*	<ul style="list-style-type: none">The vehicle specification that is written in ADAS control unit can be displayed or storedThe vehicle specification can be written when ADAS control unit is replaced
Work Support	Displays causes of automatic system cancellation occurred during system control
Self Diagnostic Result	Displays the name of a malfunctioning system stored in the ADAS control unit
Data Monitor	Displays ADAS control unit input/output data in real time
Active Test	Enables an operational check of a load by transmitting a driving signal from the ADAS control unit to the load
ECU Identification	Displays ADAS control unit part number
CAN Diag Support Monitor	Displays a reception/transmission state of CAN communication and ITS communication

*: Models with FEB system only.

CONFIGURATION

Configuration includes functions as follows.

NOTE:

Models with FEB system only.

Function	Description
Read/Write Configuration	Before Replace ECU Allows the reading of vehicle specification written in ADAS control unit to store the specification in CONSULT.
	After Replace ECU Allows the writing of the vehicle information stored in CONSULT into the ADAS control unit.
Manual Configuration	Allows the writing of the vehicle specification into the ADAS control unit by hand.

WORK SUPPORT

Work support items	Description
CAUSE OF AUTO-CANCEL 1	Displays causes of automatic system cancellation occurred during control of the following systems <ul style="list-style-type: none">Vehicle-to-vehicle control modeConventional (fixed speed) control modeDistance Control Assist (DCA)Forward Emergency Braking (FEB)
CAUSE OF AUTO-CANCEL 2	Displays causes of automatic system cancellation occurred during control of the following systems <ul style="list-style-type: none">Lane Departure Prevention (LDP) (Without DAST)Blind Spot Intervention (Without DAST)
CAUSE OF AUTO-CANCEL 3	Displays causes of automatic system cancellation occurred during control of the Back-up Collision Intervention (BCI)
FEB OPERATION MILEAGE	Displays mileage at FEB system operation
FEB DEFAULT SETTING	ON/OFF setting of FEB system at engine start can be changed

NOTE:

- Causes of the maximum five cancellations (system cancel) are displayed.
- The displayed cancellation causes display the number of the ignition switch ON/OFF up to 254. It is fixed to 254 if it is over 254. It returns to 0 when the same cancellation cause is detected again.

Display Items for The Cause of Automatic Cancellation 1

DIAGNOSIS SYSTEM (ADAS CONTROL UNIT)

< SYSTEM DESCRIPTION >

[ASCD]

Cause of cancellation	Vehicle-to-vehicle distance control mode	•Conventional (fixed speed) cruise control mode •Automatic Speed Control Device (ASCD)	Distance Control Assist	Forward Emergency Braking	Description
OPERATING ABS	×		×	×	ABS function was operated
OPERATING TCS	×	×	×		TCS function was operated
OPERATING VDC	×	×	×	×	VDC function was operated
ECM CIRCUIT	×	×			ECM did not permit ICC operation
OPE SW VOLT CIRC	×	×	×		The ICC steering switch input voltage is not within standard range
SNOW MODE SW	×		×		Shifting of the drive mode selector to SNOW position
OP SW DOUBLE TOUCH	×	×			ICC steering switches were pressed at the same time
VHCL SPD DOWN	×	×	×		Vehicle speed lower than the speed as follows <ul style="list-style-type: none"> • Vehicle-to-vehicle distance control mode is 24 km/h (15 MPH) • Conventional (fixed speed) cruise control mode is 32 km/h (20 MPH)
WHL SPD ELEC NOISE	×	×	×		Wheel speed sensor signal caught electromagnetic noise
VDC/TCS OFF SW	×		×	×	VDC OFF switch was pressed
VHCL SPD UNMATCH	×	×	×		Wheel speed became different from A/T vehicle speed
TIRE SLIP	×	×			Wheel slipped
IGN LOW VOLT	×	×	×	×	Decrease in ADAS control unit ignition voltage
PARKING BRAKE ON	×	×			The parking brake is operating
WHEEL SPD UNMATCH	×	×	×		The wheel speeds of 4 wheels are out of the specified values
INCHING LOST	×				A vehicle ahead is not detected during the following driving when the vehicle speed is approximately 24 km/h (15 MPH) or less
CAN COMM ERROR	×	×	×	×	ADAS control unit received an abnormal signal with CAN communication
ABS/TCS/VDC CIRC	×	×	×	×	An abnormal condition occurs in VDC/TCS/ABS system
ECD CIRCUIT	×	×	×	×	An abnormal condition occurs in ECD system
ENG SPEED DOWN	×	×			Engine speed became extremely low while controlling ICC system
ASCD VHCL SPD DTAC		×			Vehicle speed is detached from set vehicle speed
ASCD DOUBLE COMD		×			Cancel switch and operation switch are detected simultaneously
APA HI TEMP			×		The accelerator pedal actuator integrated motor temperature is high
ICC SENSOR CAN COMM ERR	×		×	×	Communication error between ADAS control unit and the ICC sensor
ABS WARNING LAMP	×		×		ABS warning lamp ON
FR RADAR BLOCKED	×		×	×	Inclusion of dirt or stains on the ICC sensor area of the front bumper

A
B
C
D
E
F
G
H
I
J
K
L
M
N
P

CCS

DIAGNOSIS SYSTEM (ADAS CONTROL UNIT)

< SYSTEM DESCRIPTION >

[ASCD]

FEB) CURVATURE				×	Road curve was more than the specified value
FEB) YAW RATE				×	Detected yawing speed was more than the specified value
FEB) LTRL ACCELERATION				×	Detected lateral speed is the specified value or more
RADAR INTERFERENCE	×		×	×	ICC sensor receives electromagnetic interference
LANE CAMERA BLOCKED				×	Inclusion of dirt or stain on lane camera field of view (example) window with fogging, window with dirt, strong light from front etc...)
Lane camera offset center				×	Significant change in vehicle attitude or improper installation position of lane camera NOTE: If "Lane camera offset center" is frequently detected, check vehicle attitude (e.g. tire pressure) and installation condition of lane camera. After this inspection, perform front camera aiming again.
NO RECORD	×	×	×		—

Display Items for The Cause of Automatic Cancellation 2

Cause of cancellation	Lane departure prevention	Blind spot intervention	Description
OPE VDC/TCS/ABS 1	×		The activation of VDC, TCS, or ABS during LDP system control
Vehicle dynamics	×		Vehicle behavior exceeds specified value
Steering speed	×		Steering speed was more than the specified value in evasive direction
End by yaw angle	×		Yaw angle was the end of LDP control
Departure yaw large	×		Detected more than the specified value of yaw angle in departure direction
ICC WARNING	×		Target approach warning of ICC system, FEB system, or PFCW system was activated
CURVATURE	×		Road curve was more than the specified value
Steering angle large	×		Steering angle was more than the specified value
Brake is operated	×		Brake pedal was operated
IGN LOW VOLT	×		Decrease in ADAS control unit IGN voltage
Lateral offset	×		Distance of vehicle and lane was detached in lateral direction more than the specified value
Lane marker lost	×		Lane camera unit lost the trace of lane marker
Lane marker unclear	×		Detected lane marker was unclear
Yaw acceleration	×		Detected yawing speed was more than the specified value
Deceleration large	×		Deceleration in a longitudinal direction was more than the specified value
Accel is operated	×		Accelerator pedal was depressed
Departure steering	×		Steering wheel was steered more than the specified value in departure direction
Evasive steering	×		Steering wheel was steered more than the specified value in the evasive direction
R range	×		Selector lever was operated to R range
Parking brake drift	×		Rear wheels lock was detected
Not operating condition	×		Did not meet the operating condition (vehicle speed, turn signal operation, etc.)
SNOW MODE SW	×		Shifting of the drive mode selector to SNOW position
VDC OFF SW	×		VDC OFF switch was pressed

DIAGNOSIS SYSTEM (ADAS CONTROL UNIT)

< SYSTEM DESCRIPTION >

[ASCD]

Cause of cancellation	Lane departure prevention	Blind spot intervention	Description
OPE VDC/ABS 2	×		The activation of VDC or ABS during a standby time of LDP system control
BSI WARNING	×		Blind Spot Intervention system was activated
LANE CAMERA BLOCKED	×		Inclusion of dirt or stain on lane camera field of view (example) window with fogging, window with dirt, strong light from front etc...)
Lane camera offset center	×		Significant change in vehicle attitude or improper installation position of lane camera NOTE: If "Lane camera offset center" is frequently detected, check vehicle attitude (e.g. tire pressure) and installation condition of lane camera. After this inspection, perform front camera aiming again.
BSI) OPE VDC/TCS/ABS 1		×	The activation of VDC, TCS, or ABS during Blind Spot Intervention system control
BSI) Vehicle dynamics		×	Vehicle behavior exceeds specified value
BSI) Steering speed		×	Steering speed was more than the specified value in evasive direction
BSI) End by yaw angle		×	Yaw angle was the end of Blind Spot Intervention control
BSI) Departure yaw large		×	Detected more than the specified value of yaw angle in departure direction
BSI) ICC WARNING		×	Target approach warning of ICC system, FEB system or PFCW system was activated
BSI) CURVATURE		×	Road curve was more than the specified value
BSI) Steering angle large		×	Steering angle was more than the specified value
BSI) Brake is operated		×	Brake pedal was operated
BSI) IGN LOW VOLT		×	Decrease in ADAS control unit IGN voltage
BSI) Lateral offset		×	Distance of vehicle and lane was detached in lateral direction more than the specified
BSI) Lane marker lost		×	Lane camera unit lost the trace of lane marker
BSI) Lane marker unclear		×	Detected lane marker was unclear
BSI) Yaw acceleration		×	Detected yawing speed was more than the specified value
BSI) Deceleration large		×	Deceleration in a longitudinal direction was more than the specified value
BSI) Accel is operated		×	Accelerator pedal was depressed
BSI) Departure steering		×	Steering wheel was steered more than the specified value in departure direction
BSI) Evasive steering		×	Steering wheel was steered more than the specified value in the evasive direction
BSI) R range		×	Selector lever was operated to R range
BSI) Parking brake drift		×	Rear wheels lock was detected
BSI) SNOW MODE SW		×	Shifting of the drive mode selector to SNOW position
BSI) VDC OFF SW		×	VDC OFF switch was pressed
BSI) OPE VDC/ABS 2		×	The activation of VDC or ABS during a standby time of Blind Spot Intervention system control
BSI) Not operating condition		×	Did not meet the operating condition (vehicle speed, turn signal operation, etc.)
Side Radar Lost		×	Unrecognized side radar LH or RH by the ADAS control unit
NO RECORD	×	×	—

Display Items for The Cause of Automatic Cancellation 3

DIAGNOSIS SYSTEM (ADAS CONTROL UNIT)

< SYSTEM DESCRIPTION >

[ASCD]

Cause of cancellation	Back-up Collision Intervention	Description
CAN COMM ERROR (CAN)	×	ADAS control unit received an abnormal signal with CAN communication
CAN COMM ERROR (ECD)	×	ADAS control unit received an abnormal signal with CAN communication
IGN LOW VOLT	×	Decrease in ADAS control unit ignition voltage
VEHICLE SPEED UP	×	Vehicle speed higher than 8 km/h (5 MPH)
ACCEL IS OPERATED	×	Accelerator pedal was depressed
BRAKE IS OPERATED	×	Brake pedal was operated
APA HI TEMP	×	The accelerator pedal actuator integrated motor temperature is high
APA POWER	×	Decrease in accelerator pedal actuator ignition or battery voltage
NO RECORD	×	—

FEB Default Setting

Setting item	Description
On (Factory setting)	FEB are turned ON automatically when engine started.
Off	FEB are not turned ON automatically when engine started.

SELF DIAGNOSTIC RESULT

Refer to [CCS-229, "DTC Index"](#).

NOTE:

- The details of time display are as per the following.
 - CRNT: A malfunction is detected now
 - PAST: A malfunction was detected in the past
- IGN counter is displayed on FFD (Freeze Frame Data).
 - 0: The malfunctions that are detected now
CAN communication system (U1000, U1010)
 - 1 - 39: It increases like 0 → 1 → 2 ... 38 → 39 after returning to the normal condition whenever the ignition switch OFF → ON. It returns to 0 when a malfunction is detected again in the process.
 - If it is over 39, it is fixed to 39 until the self-diagnosis results are erased.
 - Other than CAN communication system (Other than U1000, U1010)
 - 1 - 49: It increases like 0 → 1 → 2 ... 38 → 49 after returning to the normal condition whenever the ignition switch OFF → ON. It returns to 0 when a malfunction is detected again in the process.
 - If it is over 49, it is fixed to 49 until the self-diagnosis results are erased.

DATA MONITOR

NOTE:

The following table includes information (items) inapplicable to this vehicle. For information (items) applicable to this vehicle, refer to CONSULT display items.

DIAGNOSIS SYSTEM (ADAS CONTROL UNIT)

< SYSTEM DESCRIPTION >

[ASCD]

Monitored item [Unit]	ALL SIG	ALL SIG (ICC)	MAIN SIG (ICC)	MAIN SIG (LDW/LDP)	MAIN SIG (BSW/BSI)	MAIN SIG (BCI)	Description
MAIN SW [On/Off]	×	×	×	×	×		Indicates [On/Off] status as judged from ICC steering switch
SET/COAST SW [On/Off]	×	×	×				Indicates [On/Off] status as judged from ICC steering switch
CANCEL SW [On/Off]	×	×	×				Indicates [On/Off] status as judged from ICC steering switch
RESUME/ACC SW [On/Off]	×	×	×				Indicates [On/Off] status as judged from ICC steering switch
DISTANCE SW [On/Off]	×	×					Indicates [On/Off] status as judged from ICC steering switch
CRUISE OPE [On/Off]	×	×	×				Indicates whether controlling or not (ON means “controlling”)
BRAKE SW [On/Off]	×	×	×	×	×	×	Indicates [On/Off] status as judged from ICC brake switch signal (ECM transmits ICC brake switch signal through CAN communication)
STOP LAMP SW [On/Off]	×	×	×	×	×	×	Indicates [On/Off] status as judged from stop lamp switch signal (ECM transmits stop lamp switch signal through CAN communication)
IDLE SW [On/Off]	×	×				×	Indicates [On/Off] status of idle switch read from ADAS control unit through CAN communication (ECM transmits On/Off status through CAN communication)
SET DISTANCE [Short/Mid/Long]	×	×	×				Indicates set distance memorized in ADAS control unit
CRUISE LAMP [On/Off]	×	×	×				Indicates [On/Off] status of MAIN switch indicator output
OWN VHCL [On/Off]	×	×					NOTE: The item is displayed, but it is not monitored
VHCL AHEAD [On/Off]	×	×					Indicates [On/Off] status of vehicle ahead detection indicator output
ICC WARNING [On/Off]	×	×					Indicates [On/Off] status of ICC system warning lamp output
VHCL SPEED SE [km/h] or [mph]	×	×	×	×	×	×	Indicates vehicle speed calculated from ADAS control unit through CAN communication [ABS actuator and electric unit (control unit) transmits vehicle speed signal (wheel speed) through CAN communication]
SET VHCL SPD [km/h] or [mph]	×	×	×				Indicates set vehicle speed memorized in ADAS control unit
BUZZER O/P [On/Off]	×	×				×	Indicates [On/Off] status of ICC warning chime output
THRTL SENSOR [deg]	×	×	×				NOTE: The item is displayed, but it is not monitored
ENGINE RPM [rpm]	×	×					Indicates engine speed read from ADAS control unit through CAN communication (ECM transmits engine speed signal through CAN communication)
WIPER SW [OFF/LOW/HIGH]	×	×					Indicates wiper [OFF/LOW/HIGH] status (BCM transmits front wiper request signal through CAN communication)
YAW RATE [deg/s]	×	×					NOTE: The item is displayed, but it is not monitored
BA WARNING [On/Off]	×	×					Indicates [On/Off] status of FEB indicator lamp output

A
B
C
D
E
F
G
H
I
J
K
L
M
N
P

CCS

DIAGNOSIS SYSTEM (ADAS CONTROL UNIT)

< SYSTEM DESCRIPTION >

[ASCD]

Monitored item [Unit]	ALL SIG	ALL SIG (ICC)	MAIN SIG (ICC)	MAIN SIG (LDW/LDP)	MAIN SIG (BSW/BSI)	MAIN SIG (BCI)	Description
RELEASE SW NO [On/Off]	×	×		×	×	×	NOTE: The item is displayed, but it is not monitored
RELEASE SW NC [On/Off]	×	×		×	×	×	NOTE: The item is displayed, but it is not monitored
STP LMP DRIVE [On/Off]	×	×	×			×	Indicates [On/Off] status of ICC brake hold relay drive output
PRESS SENS [bar]	×	×	×				NOTE: The item is displayed, but it is not monitored
D RANGE SW [On/Off]	×	×					Indicates [On/Off] status of "D" or "M" positions read from ADAS control unit through CAN communication; ON when position "D" or "M" (TCM transmits shift position signal through CAN communication).
NP RANGE SW [On/Off]	×	×					Indicates shift position signal read from ADAS control unit through CAN communication (TCM transmits shift position signal through CAN communication)
PKB SW [On/Off]	×	×					Parking brake switch status [On/Off] judged from the parking brake switch signal that ADAS control unit readout via CAN communication is displayed (combination meter transmits the parking brake switch signal via CAN communication)
PWR SUP MONI [V]	×	×	×				Indicates IGN voltage input by ADAS control unit
VHCL SPD AT [km/h] or [mph]	×	×					Indicates vehicle speed calculated from A/T vehicle speed sensor read from ADAS control unit through CAN communication (TCM transmits A/T vehicle speed sensor signal through CAN communication)
THRTL OPENING [%]	×	×	×			×	Indicates throttle position read from ADAS control unit through CAN communication (ECM transmits accelerator pedal position signal through CAN communication).
GEAR [1, 2, 3, 4, 5, 6, 7]	×	×					Indicates A/T gear position read from ADAS control unit through CAN communication (TCM transmits current gear position signal through CAN communication)
MODE SIG [OFF, ICC, ASCD]	×	×					Indicates the active mode from ICC or ASCD [conventional (fixed speed) cruise control mode]
SET DISP IND [On/Off]	×	×					Indicates [On/Off] status of SET switch indicator output
DISTANCE [m]	×	×					Indicates the distance from the vehicle ahead
RELATIVE SPD [m/s]	×	×					Indicates the relative speed of the vehicle ahead
DYNA ASIST SW [On/Off]	×	×	×		×		Indicates [On/Off] status as judged from ICC steering switch signal (ECM transmits ICC steering switch signal through CAN communication)
DCA ON IND [On/Off]	×	×					The status [ON/OFF] of DCA system switch indicator output is displayed
DCA VHL AHED [On/Off]	×	×					The status [ON/OFF] of vehicle ahead detection indicator output in DCA system is displayed
APA TEMP [°C]	×	×				×	Accelerator pedal actuator integrated motor temperature that the ADAS control unit readout via ITS communication is displayed (Accelerator pedal actuator transmits the integrated motor temperature via ITS communication)
FCW MAIN SW							NOTE: The item is displayed, but it is not monitored

DIAGNOSIS SYSTEM (ADAS CONTROL UNIT)

< SYSTEM DESCRIPTION >

[ASCD]

Monitored item [Unit]	ALL SIG	ALL SIG (ICC)	MAIN SIG (ICC)	MAIN SIG (LDW/LDP)	MAIN SIG (BSW/BSI)	MAIN SIG (BCI)	Description
APA PWR [V]	×	×				×	Accelerator pedal actuator power supply voltage that the ADAS control unit readout via ITS communication is displayed (Accelerator pedal actuator transmits the power supply voltage via ITS communication)
NAVI-ICC DISP [On/Off]	×	×					NOTE: The item is displayed, but it is not monitored
LDW SYSTEM ON [On/Off]	×			×			Indicates [On/Off] status of LDW system
LANE DPRT W/L [On/Off]	×			×			Indicates [On/Off] status of LDW/LDP warning display (Yellow) output
LDW BUZER OUT- PUT [On/Off]	×			×			Indicates [On/Off] status of warning buzzer output
LDP SYSTEM ON [On/Off]	×			×			Indicates [On/Off] status of LDP system
WARN REQ [On/Off]	×			×			Indicates an ADAS control unit judged warning state (ON/OFF) of LDP system
READY signal [On/Off]	×			×			Indicates LDP system settings
Camera lost [Detect/Deviate/Both]	×			×	×		Indicates a lane marker detection state judged from a lane marker detection signal read by the ADAS control unit via ITS communication (Lane camera unit transmits a lane marker signal via ITS communication)
Lane unclear [On/Off]	×			×	×		Indicates an ON/OFF state of the lane marker. The ON/OFF state is judged from a detected lane condition signal read by the ADAS control unit via ITS communication (The lane camera unit transmits a detected lane condition signal via ITS communication)
STATUS signal [Stnby/Warn/Cancel/ Off]	×			×			Indicates a control state of LDP system
Shift position [Off, P, R, N, D, M/T1 - 7]	×			×	×	×	Indicates shift position read from ADAS control unit through CAN communication (TCM transmits shift position signal through CAN communication)
Turn signal [OFF/LH/RH/LH&RH]	×			×	×		Indicates turn signal operation status read from ADAS control unit through CAN communication (BCM transmits turn indicator signal through CAN communication)
SIDE G [G]	×			×	×		Indicates lateral G acting on the vehicle. This lateral G is judged from a side G sensor signal read by ADAS control unit via CAN communication (The ABS actuator and electric unit (control unit) transmits a side G sensor signal via CAN communication)
FUNC ITEM (FCW) [On/Off]	×	×	×	×	×		Indicates systems which can be set to ON/OFF by selecting "Driver Aids" ⇒ "Emergency Assist" of the integral switch Forward Emergency Braking
FUNC ITEM (LDW) [On/Off]	×	×	×	×	×		Indicates systems which can be set to ON/OFF by selecting "Driver Aids" ⇒ "Lane" of the integral switch Lane Departure Warning
FUNC ITEM (BSW) [On/Off]	×	×	×	×	×		Indicates systems which can be set to ON/OFF by selecting "Driver Aids" ⇒ "Blind spot" of the integral switch Blind Spot Warning
FUNC ITEM (NV-ICC) [Off]	×	×	×	×	×		NOTE: The item is displayed, but it is not monitored

A
B
C
D
E
F
G
H
I
J
K
L
M
N

CCS

P

DIAGNOSIS SYSTEM (ADAS CONTROL UNIT)

< SYSTEM DESCRIPTION >

[ASCD]

Monitored item [Unit]	ALL SIG	ALL SIG (ICC)	MAIN SIG (ICC)	MAIN SIG (LDW/LDP)	MAIN SIG (BSW/BSI)	MAIN SIG (BCI)	Description
FUNC ITEM (NV-DCA) [Off]	×	×	×	×	×		NOTE: The item is displayed, but it is not monitored
DCA SELECT [On/Off]	×	×	×	×	×		Indicates an ON/OFF state of the DCA system. The DCA system can be set to ON/OFF by selecting "Driving Aids" ⇒ "Front assist" of the integral switch
LDP SELECT [On/Off]	×	×	×	×	×		Indicates an ON/OFF state of LDP system. LDP system can be set to ON/OFF by selecting "Driving Aids" ⇒ "Lane" of the integral switch
BSI SELECT [On/Off]	×	×	×	×	×		Indicates an ON/OFF state of Blind Spot Intervention system. Blind Spot Intervention system can be set to ON/OFF by selecting "Driving Aids" ⇒ "Blind Spot" of the integral switch
FCW SELECT [On/Off]	×	×	×	×	×		Indicates an ON/OFF state of the PFCW system. The PFCW system can be set to ON/OFF by selecting "Driving Aids" ⇒ "Emergency Assist" of the integral switch
LDW SELECT [On/Off]	×	×	×	×	×		Indicates an ON/OFF state of the LDW system. The LDW system can be set to ON/OFF by selecting "Driving Aids" ⇒ "Lane" of the integral switch
BSW SELECT [On/Off]	×	×	×	×	×		Indicates an ON/OFF state of the BSW system. The BSW system can be set to ON/OFF by selecting "Driving Aids" ⇒ "Blind spot" of the integral switch
NAVI ICC SELECT [Off]	×	×	×	×	×		NOTE: The item is displayed, but it is not monitored
NAVI DCA SELECT [Off]	×	×	×	×	×		NOTE: The item is displayed, but it is not monitored
DRIVE MODE STATS [STD/SPORT/ECO/ SNOW/MID/ERROR]	×	×	×	×	×		Indicates a drive mode selector select position judged from a drive mode select switch position signal read by the ADAS control unit via CAN communication (The chassis control module transmits a switch position signal of the drive mode select switch signal via CAN communication)
BSW/BSI WARN LMP [On/Off]	×				×		Indicates [On/Off] status of Blind Spot warning malfunction
BSI ON IND [On/Off]	×				×		Indicates [On/Off] status of Blind Spot Intervention system display
BSW SYSTEM ON [On/Off]	×				×		Indicates [On/Off] status of BSW system
BSI SYSTEM ON [On/Off]	×				×		Indicates [On/Off] status of Blind Spot Intervention system
FCW SYSTEM ON [On/Off]	×	×	×				Indicates [On/Off] status of PFCW system
BCI SYSTEM ON [On/Off]	×					×	Indicates [On/Off] status of BCI system
BATTERY CIRCUIT OFF [On/Off]	×						NOTE: The item is displayed, but it is not used
LDP WARNING INDICATOR [On/Off]	×			×			Indicates [On/Off] status of LDP warning display (Yellow) output
LDW ON INDICATOR [On/Off]	×			×			Indicates [On/Off] status of LDW system ON display output
LDW WARNING INDICATOR [On/Off]	×			×			Indicates [On/Off] status of LDW system warning display output

DIAGNOSIS SYSTEM (ADAS CONTROL UNIT)

< SYSTEM DESCRIPTION >

[ASCD]

Monitored item [Unit]	ALL SIG	ALL SIG (ICC)	MAIN SIG (ICC)	MAIN SIG (LDW/LDP)	MAIN SIG (BSW/BSI)	MAIN SIG (BCI)	Description
SYSTEM CANCEL MESSAGE [NOREQ/SLIP/ SNOW/VDC OFF]	×	×	×	×	×		Indicates status of system cancel display output
CAMERA HI TEMP MSG [On/Off]	×			×	×		Indicates [On/Off] status of lane camera unit high temperature warning display output
ITS SETTING ITEM(DCA) [On/Off]	×	×	×	×	×		Indicates the presence or absence of DCA system.
ITS SETTING ITEM(LDP) [On/Off]	×	×	×	×	×		Indicates the presence or absence of LDP system.
ITS SETTING ITEM(BSI) [On/Off]	×	×	×	×	×		Indicates the presence or absence of Blind Spot Intervention system.
BSI WARNING INDICATOR [On/Off]	×				×		Indicates [On/Off] status of Blind Spot Intervention warning display output
BSW ON INDICATOR [On/Off]	×				×		Indicates [On/Off] status of BSW system ON display output
SIDE RADAR BLOCK COND [On/Off]	×				×		Indicates [On/Off] status of side radar with dirt or foreign materials
LDW WARNING ALERT TIMING [Nothing/Early/Late]	×			×			NOTE: The item is displayed, but it is not monitored
BSW IND BRIGHTNESS [Nothing/Bright/Normal/Dark]	×				×		Indicates status of brightness of Blind Spot Warning/Blind Spot Intervention indicator
SL MAIN SW [On/Off]	×		×				Indicates [On/Off] status as judged from steering switch
PMAS SW [On/Off]	×						NOTE: The item is displayed, but it is not monitored
PMAS IND [On/Off]	×						NOTE: The item is displayed, but it is not monitored
FUNC ITEM(FEB) [On/Off]	×						Indicates systems which can be set to ON/OFF by selecting "Driver Aids" ⇒ "Emergency Assist" of the integral switch Forward Emergency Braking
FEB SELECT [On/Off]	×						Indicates an ON/OFF state of the FEB system. The FEB system can be set to ON/OFF by selecting "Driving Aids" ⇒ "Emergency Assist" of the integral switch
FEB SW [On/Off]	×						Indicates [On/Off] status of FEB system
G SENSOR SIGNAL [On/Off]	×						NOTE: The item is displayed, but it is not used
PMAS BUZZER REQ 1 [On/Off]	×						NOTE: The item is displayed, but it is not used
PMAS BUZZER REQ 2 [On/Off]	×						NOTE: The item is displayed, but it is not used

A
B
C
D
E
F
G
H
I
J
K
L
M
N
P

CCS

DIAGNOSIS SYSTEM (ADAS CONTROL UNIT)

< SYSTEM DESCRIPTION >

[ASCD]

Monitored item [Unit]	ALL SIG	ALL SIG (ICC)	MAIN SIG (ICC)	MAIN SIG (LDW/LDP)	MAIN SIG (BSW/BSI)	MAIN SIG (BCI)	Description
PMAS BUZZER REQ 3 [On/Off]	×						NOTE: The item is displayed, but it is not used
SL TARGET VEHI- CLE SPEED [km/h]	×	×					Indicates set vehicle speed memorized in ADAS control unit
SL SET LAMP [On/Off]	×	×					Indicates [On/Off] status of speed limiter SET display output
SL LIMIT LAMP [On/Off]	×	×					Indicates [On/Off] status of speed limiter MAIN switch display output
ASCD CANCEL (LOW SPEED) [NON/CUT]	×	×					Indicates the vehicle cruise condition. <ul style="list-style-type: none"> • NON: Vehicle speed is maintained at the ASCD set speed. • CUT: Vehicle speed decreased to excessively low, and ASCD operation is cut off.
ASCD CANCEL (SPEED DIFF) [NON/CUT]	×	×					Indicates the vehicle cruise condition. <ul style="list-style-type: none"> • NON: Vehicle speed is maintained at the ASCD set speed. • CUT: Vehicle speed decreased to excessively low compared with the ASCD set speed, and ASCD operation is cut off.
KICK DOWN [On/Off]	×	×					Display Kick Down decision state. <ul style="list-style-type: none"> • On: Accelerator pedal is depressed • Off: Accelerator pedal is fully released

ACTIVE TEST

CAUTION:

- **Never perform “Active Test” while driving the vehicle.**
- **The “Active Test” cannot be performed when the following systems malfunction is displayed.**
 - ICC system
 - DCA
 - LDW
 - LDP
 - Blind Spot Warning
 - Blind Spot Intervention
 - BCI
- **The “Active Test” cannot be performed when the FEB warning lamp is illuminated.**
- **Shift the selector lever to “P” position, and then perform the test.**

Test item	Description
BRAKE ACTUATOR	Activates the brake by an arbitrary operation
ICC BUZZER	Sounds a buzzer used for following systems by arbitrarily operating ON/OFF <ul style="list-style-type: none"> • Intelligent Cruise Control (ICC) • Distance Control Assist (DCA) • Predictive Forward Collision Warning (PFCW) • Forward Emergency Brake (FEB)
METER LAMP	The MAIN switch indicator and FEB warning lamp can be illuminated by ON/OFF operations as necessary
STOP LAMP	The ICC brake hold relay can be operated by ON/OFF operations as necessary, and the stop lamp can be illuminated
ACTIVE PEDAL	The accelerator pedal actuator can be operated as necessary
DCA INDICATOR	The DCA system display can be illuminated by ON/OFF operations as necessary
LDP BUZZER	Sounds a buzzer used for following systems by arbitrarily operating ON/OFF <ul style="list-style-type: none"> • Lane Departure Warning (LDW) • Lane Departure Prevention (LDP) • Blind Spot Warning (BSW) • Blind Spot Intervention

DIAGNOSIS SYSTEM (ADAS CONTROL UNIT)

< SYSTEM DESCRIPTION >

[ASCD]

Test item	Description
LDP ON IND	The LDP system display can be illuminated by ON/OFF operations as necessary
LANE DEPARTURE W/L	The LDW/LDP warning can be illuminated by ON/OFF operations as necessary
BSW/BSI WARNING INDICATOR	The BSW malfunction can be illuminated by ON/OFF operations as necessary
BSI ON INDICATOR	The Blind Spot Intervention system display can be illuminated by ON/OFF operations as necessary
LDW ON INDICATOR	The LDW system display can be illuminated by ON/OFF operations as necessary
LDP WARNING INDICATOR	The LDP malfunction can be illuminated by ON/OFF operations as necessary
LDW WARNING INDICATOR	The LDW malfunction can be illuminated by ON/OFF operations as necessary
BSW ON INDICATOR	The Blind Spot Warning system display can be illuminated by ON/OFF operations as necessary
BSI WARNING INDICATOR	The Blind Spot Intervention malfunction can be illuminated by ON/OFF operations as necessary

BRAKE ACTUATOR

NOTE:

The test can be performed only when the engine is running.

Test item	Operation	Description	"PRESS SENS" value
BRAKE ACTUATOR	MODE1	Transmits the brake fluid pressure control signal to the ABS actuator and electric unit (control unit) via chassis control module	10 bar
	MODE2		20 bar
	MODE3		30 bar
	Test start	Starts the tests of "MODE1", "MODE2" and "MODE3"	—
	Reset	Stops transmitting the brake fluid pressure control signal below to end the test	—
	End	Returns to the "SELECT TEST ITEM" screen	—

NOTE:

The test is finished in 10 seconds after starting

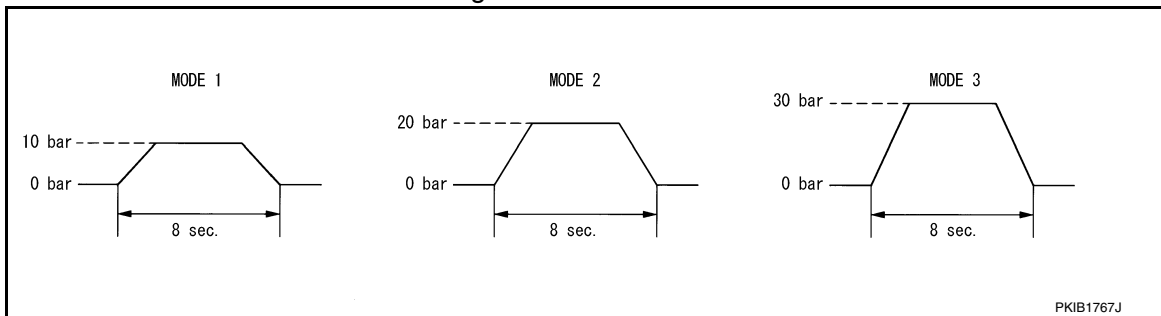

ICC BUZZER

Test item	Operation	Description	Operation sound
ICC BUZZER	MODE1	Transmits the buzzer output signals to the ADAS control unit 2 via ITS communication	Intermittent beep sound
	Test start	Starts the tests of "MODE1"	—
	Reset	Stops transmitting the buzzer output signal below to end the test	—
	End	Returns to the "SELECT TEST ITEM" screen	—

METER LAMP

NOTE:

The test can be performed only when the engine is running.

DIAGNOSIS SYSTEM (ADAS CONTROL UNIT)

< SYSTEM DESCRIPTION >

[ASCD]

Test item	Operation	Description	
METER LAMP	Off	Stops sending the following signals to exit from the test • Meter display signal • FEB warning lamp signal	OFF
	On	Transmits the following signals to the combination meter via CAN communication • Meter display signal • FEB warning lamp signal	ON

STOP LAMP

Test item	Operation	Description	Stop lamp
STOP LAMP	Off	Stops transmitting the ICC brake hold relay drive signal below to end the test	OFF
	On	Transmits the ICC brake hold relay drive signal	ON

ACTIVE PEDAL

CAUTION:

- Shift the selector lever to “P” position, and then perform the test.
- Never depress the accelerator pedal excessively. (The engine speed may rise unexpectedly when finishing the test.)

NOTE:

- Depress the accelerator pedal to check when performing the test.
- The test can be performed only when the engine is running.

Test item	Operation	Description	Accelerator pedal operation
ACTIVE PEDAL	MODE1	Transmit the accelerator pedal feedback force control signal to the accelerator pedal actuator via ITS communication.	Constant with a force of 25 N for 8 seconds
	MODE2		Constant with a force of 15 N for 8 seconds
	MODE3		Change up to a force of 25 N for 8 seconds
	MODE4		Change up to a force of 15 N for 8 seconds
	Test start	Starts the tests of “MODE1”, “MODE2”, “MODE3” and “MODE4”	—
	Reset	Stops transmitting the accelerator pedal feedback force control signal below to end the test.	—
	End	Returns to the “SELECT TEST ITEM” screen	—

NOTE:

The test is finished in 10 seconds after starting

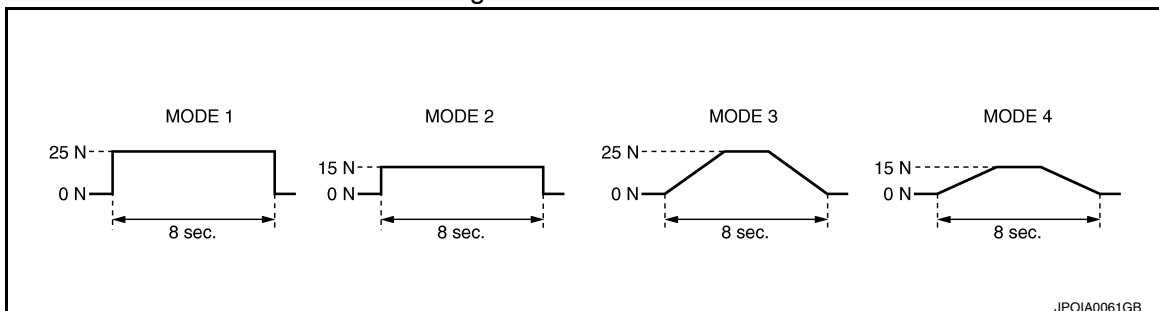

DCA INDICATOR

NOTE:

The test can be performed only when the engine is running.

DIAGNOSIS SYSTEM (ADAS CONTROL UNIT)

< SYSTEM DESCRIPTION >

[ASCD]

Test item	Operation	Description	DCA system display
DCA INDICATOR	Off	Stops transmitting the meter display signal below to end the test	—
	On	Transmits the meter display signal to the combination meter via CAN communication	ON

LDP BUZZER

Test item	Operation	Description	Warning buzzer
LDP BUZZER	Off	Stops transmitting the warning buzzer signal below to end the test	—
	On	Transmits the warning buzzer signal to the warning buzzer	ON

LDP ON IND

Test item	Operation	Description	LDP system display (Green)
LDP ON IND	Off	Stops transmitting the meter display signal below to end the test	—
	On	Transmits the meter display signal to the combination meter via CAN communication	ON

LANE DEPARTURE W/L

Test item	Operation	Description	Lane departure system display (Yellow)
LANE DEPARTURE W/L	Off	Stops transmitting the meter display signal below to end the test	—
	On	Transmits the meter display signal to the combination meter via CAN communication	ON

BSW/BSI WARNING INDICATOR

Test item	Operation	Description	BSW malfunction (Yellow)
BSW/BSI WARNING INDICATOR	Off	Stops transmitting the meter display signal below to end the test	—
	On	Transmits the meter display signal to the combination meter via CAN communication	ON

BSI ON INDICATOR

Test item	Operation	Description	Blind Spot Intervention system display (Green)
BSI ON INDICATOR	Off	Stops transmitting the meter display signal below to end the test	—
	On	Transmits the meter display signal to the combination meter via CAN communication	ON

LDW ON INDICATOR

Test item	Operation	Description	LDW system display (White)
LDW ON INDICATOR	Off	Stops transmitting the meter display signal below to end the test	—
	On	Transmits the meter display signal to the combination meter via CAN communication	ON

DIAGNOSIS SYSTEM (ADAS CONTROL UNIT)

< SYSTEM DESCRIPTION >

[ASCD]

LDP WARNING INDICATOR

Test item	Operation	Description	LDP malfunction (Yellow)
LDP WARNING INDICATOR	Off	Stops transmitting the meter display signal below to end the test	—
	On	Transmits the meter display signal to the combination meter via CAN communication	ON

LDW WARNING INDICATOR

Test item	Operation	Description	LDW malfunction (Yellow)
LDW WARNING INDICATOR	Off	Stops transmitting the meter display signal below to end the test	—
	On	Transmits the meter display signal to the combination meter via CAN communication	ON

BSW ON INDICATOR

Test item	Operation	Description	Blind Spot Warning system display (Yellow)
BSW ON INDICATOR	Off	Stops transmitting the meter display signal below to end the test	—
	On	Transmits the meter display signal to the combination meter via CAN communication	ON

BSI WARNING INDICATOR

Test item	Operation	Description	Blind Spot Intervention malfunction (Yellow)
BSI WARNING INDICATOR	Off	Stops transmitting the meter display signal below to end the test	—
	On	Transmits the meter display signal to the combination meter via CAN communication	ON

ECU IDENTIFICATION

Displays ADAS control unit parts number.

ADAS CONTROL UNIT

< ECU DIAGNOSIS INFORMATION >

[ASCD]

ECU DIAGNOSIS INFORMATION

ADAS CONTROL UNIT

Reference Value

INFOID:0000000013965374

VALUES ON THE DIAGNOSIS TOOL

NOTE:

The following table includes information (items) inapplicable to this vehicle. For information (items) applicable to this vehicle, refer to CONSULT display items.

Monitor item	Condition	Value/Status	
MAIN SW	Ignition switch ON	When MAIN switch is pressed	On
		When MAIN switch is not pressed	Off
SET/COAST SW	Ignition switch ON	When SET/COAST switch is pressed	On
		When SET/COAST switch is not pressed	Off
CANCEL SW	Ignition switch ON	When CANCEL switch is pressed	On
		When CANCEL switch is not pressed	Off
RESUME/ACC SW	Ignition switch ON	When RESUME/ACCELERATE switch is pressed	On
		When RESUME/ACCELERATE switch is not pressed	Off
DISTANCE SW	Ignition switch ON	When DISTANCE switch is pressed	On
		When DISTANCE switch is not pressed	Off
CRUISE OPE	Drive the vehicle and activate the vehicle-to-vehicle distance control mode	When ICC system is controlling	On
		When ICC system is not controlling	Off
BRAKE SW	Ignition switch ON	When brake pedal is depressed	Off
		When brake pedal is not depressed	On
STOP LAMP SW	Ignition switch ON	When brake pedal is depressed	On
		When brake pedal is not depressed	Off
IDLE SW	Engine running	Idling	On
		Except idling (depress accelerator pedal)	Off
SET DISTANCE	<ul style="list-style-type: none"> • Start the engine and turn the ICC system ON • Press the DISTANCE switch to change the vehicle-to-vehicle distance setting 	When set to "long"	Long
		When set to "middle"	Mid
		When set to "short"	Short
CRUISE LAMP	Start the engine and press MAIN switch	ICC system ON (MAIN switch indicator ON)	On
		ICC system OFF (MAIN switch indicator OFF)	Off
OWN VHCL	<p>NOTE: The item is indicated, but not monitored</p>	Off	
VHCL AHEAD	Drive the vehicle and activate the vehicle-to-vehicle distance control mode	When a vehicle ahead is detected (vehicle ahead detection indicator ON)	On
		When a vehicle ahead is not detected (vehicle ahead detection indicator OFF)	Off
ICC WARNING	Start the engine and press MAIN switch	When ICC system is malfunctioning (ICC system malfunction ON)	On
		When ICC system is normal (ICC system malfunction OFF)	Off

A
B
C
D
E
F
G
H
I
J
K
L
M
N
P

CCS

ADAS CONTROL UNIT

< ECU DIAGNOSIS INFORMATION >

[ASCD]

Monitor item	Condition		Value/Status
VHCL SPEED SE	While driving		Displays the vehicle speed calculated by ADAS control unit
SET VHCL SPD	While driving	When vehicle speed is set	Displays the set vehicle speed
BUZZER O/P	Engine running	When the buzzer of the following system operates <ul style="list-style-type: none"> • Vehicle-to-vehicle distance control mode • DCA system • PFCW system • FEB system 	On
		When the buzzer of the following system not operates <ul style="list-style-type: none"> • Vehicle-to-vehicle distance control mode • DCA system • PFCW system • FEB system 	Off
THRTL SENSOR	NOTE: The item is indicated, but not monitored		0.0
ENGINE RPM	Engine running		Equivalent to tachometer reading
WIPER SW	Ignition switch ON	Wiper not operating	Off
		Wiper LO operation	Low
		Wiper HI operation	High
YAW RATE	NOTE: The item is indicated, but not monitored		0.0
BA WARNING	Engine running	FEB OFF indicator lamp ON <ul style="list-style-type: none"> • When FEB system is malfunctioning • When FEB system is turned to OFF 	On
		FEB OFF indicator lamp OFF <ul style="list-style-type: none"> • When FEB system is normal • When FEB system is turned to ON 	Off
RELEASE SW NO	NOTE: The item is indicated, but not monitored		—
RELEASE SW NC	NOTE: The item is indicated, but not monitored		—
STP LMP DRIVE	Drive the vehicle and activate the vehicle-to-vehicle distance control mode	When ICC brake hold relay is activated	On
		When ICC brake hold relay is not activated	Off
PRESS SENS	NOTE: The item is indicated, but not monitored		—
D RANGE SW	Engine running	When the selector lever is in "D" position or manual mode	On
		When the selector lever is in any position other than "D" or manual mode	Off
NP RANGE SW	Engine running	When the selector lever is in "N", "P" position	On
		When the selector lever is in any position other than "N", "P"	Off
PKB SW	Ignition switch ON	When the parking brake is applied	On
		When the parking brake is released	Off
PWR SUP MONI	Engine running		Power supply voltage value of ADAS control unit

ADAS CONTROL UNIT

< ECU DIAGNOSIS INFORMATION >

[ASCD]

Monitor item	Condition		Value/Status
VHCL SPD AT	While driving		Value of A/T vehicle speed sensor signal
THRTL OPENING	Engine running	Depress accelerator pedal	Displays the throttle position
GEAR	While driving		Displays the gear position
MODE SIG	Start the engine and press MAIN switch	When ICC system is deactivated	Off
		When vehicle-to-vehicle distance control mode is activated	ICC
		When conventional (fixed speed) cruise control mode is activated	ASCD
SET DISP IND	<ul style="list-style-type: none"> • Drive the vehicle and activate the conventional (fixed speed) cruise control mode • Press SET/COAST switch 	SET switch indicator ON	On
		SET switch indicator OFF	Off
DISTANCE	Drive the vehicle and activate the vehicle-to-vehicle distance control mode	When a vehicle ahead is detected	Displays the distance from the preceding vehicle
		When a vehicle ahead is not detected	0.0
RELATIVE SPD	Drive the vehicle and activate the vehicle-to-vehicle distance control mode	When a vehicle ahead is detected	Displays the relative speed.
		When a vehicle ahead is not detected	0.0
DYNA ASIST SW	Ignition switch ON	When dynamic driver assistance switch is pressed	On
		When dynamic driver assistance switch is not pressed	Off
DCA ON IND	Start the engine and press dynamic driver assistance switch (When DCA setting is ON)	DCA system OFF	Off
		DCA system ON	On
DCA VHL AHED	Drive the vehicle and activate the DCA system	When a vehicle ahead is not detected (vehicle ahead detection indicator OFF)	Off
		When a vehicle ahead is detected (vehicle ahead detection indicator ON)	On
APA TEMP	Engine running		Display the accelerator pedal actuator integrated motor temperature
FCW MAIN SW	NOTE: The item is indicated, but not monitored		—
APA PWR	Ignition switch ON		Power supply voltage value of accelerator pedal actuator
NAVI-ICC DISP	NOTE: The item is indicated, but not monitored		Off
LDW SYSTEM ON	Ignition switch ON	When the LDW system is ON	On
		When the LDW system is OFF	Off
LANE DPRT W/L	Drive the vehicle and activate the LDW system or LDP system	Lane departure warning lamp ON	On
		Lane departure warning lamp OFF	Off

A
B
C
D
E
F
G
H
I
J
K
L
M
N
P

CCS

ADAS CONTROL UNIT

< ECU DIAGNOSIS INFORMATION >

[ASCD]

Monitor item	Condition		Value/Status
LDW BUZER OUT-PUT	Drive the vehicle and activate the LDW/LDP system or Blind Spot Warning/Blind Spot Intervention system	When the buzzer of the following system operates • LDW/LDP system • Blind Spot Warning/Blind Spot Intervention system	On
		When the buzzer of the following system does not operate • LDW/LDP system • Blind Spot Warning/Blind Spot Intervention system	Off
LDP SYSTEM ON	Start the engine and press dynamic driver assistance switch (When LDP system setting is ON)	When the LDP system is ON	On
		When the LDP system is OFF	Off
WARN REQ	Drive the vehicle and activate the LDP system	Lane departure warning is operating	On
		Lane departure warning is not operating	Off
READY signal	Start the engine and press dynamic driver assistance switch (When LDP system setting is ON)	When the LDP system is ON	On
		When the LDP system is OFF	Off
Camera lost	Drive the vehicle and activate the LDW system, LDP system or Blind Spot Intervention system	Both side lane markers are detected	Detect
		Deviate side lane marker is lost	Deviate
		Both side lane markers are lost	Both
Lane unclear	While driving	Lane marker is unclear	On
		Lane marker is clear	Off
STATUS signal	Drive the vehicle and activate the LDP system	When the LDP system is ON	Stnby
		When the LDP system is operating	Warn
		When the LDP system is canceled	Cancl
		When the LDP system is OFF	Off
Shift position	<ul style="list-style-type: none"> • Engine running • While driving 		Displays the shift position
Turn signal	Turn signal lamps OFF		Off
	Turn signal lamp LH blinking		LH
	Turn signal lamp RH blinking		RH
	Turn signal lamp LH and RH blinking		LH&RH
SIDE G	While driving	Vehicle turning right	Negative value
		Vehicle turning left	Positive value
FUNC ITEM (FCW)	Engine running	"Forward Emergency Braking" set with the integral switch is ON	On
		"Forward Emergency Braking" set with the integral switch is OFF	Off
FUNC ITEM (LDW)	Engine running	"Lane Departure Warning" set with the integral switch is ON	On
		"Lane Departure Warning" set with the integral switch is OFF	Off
FUNC ITEM (BSW)	Engine running	"Blind Spot Warning" set with the integral switch is ON	On
		"Blind Spot Warning" set with the integral switch is OFF	Off
FUNC ITEM (NV-ICC)	NOTE: The item is indicated, but not monitored		Off
FUNC ITEM (NV-DCA)	NOTE: The item is indicated, but not monitored		Off

ADAS CONTROL UNIT

< ECU DIAGNOSIS INFORMATION >

[ASCD]

Monitor item	Condition		Value/Status
DCA SELECT	Ignition switch ON	"Distance Control Assist" set with the integral switch is ON	On
		"Distance Control Assist" set with the integral switch is OFF	Off
LDP SELECT	Ignition switch ON	"Lane Departure Intervention" set with the integral switch is ON	On
		"Lane Departure Intervention" set with the integral switch is OFF	Off
BSI SELECT	Ignition switch ON	"Blind Spot Intervention" set with the integral switch is ON	On
		"Blind Spot Intervention" set with the integral switch is OFF	Off
FCW SELECT	Ignition switch ON	"Forward Emergency Braking" set with the integral switch is ON	On
		"Forward Emergency Braking" set with the integral switch is OFF	Off
LDW SELECT	Ignition switch ON	"Lane Departure Warning" set with the integral switch is ON	On
		"Lane Departure Warning" set with the integral switch is OFF	Off
BSW SELECT	Ignition switch ON	"Blind Spot Warning" set with the integral switch is ON	On
		"Blind Spot Warning" set with the integral switch is OFF	Off
NAVI ICC SELECT	NOTE: The item is indicated, but not monitored		Off
NAVI DCA SELECT	NOTE: The item is indicated, but not monitored		Off
DRIVE MODE STATS	Ignition switch ON	When drive mode select switch position is STANDARD	STD
		When drive mode select switch position is in SPORT	SPORT
		When drive mode select switch position is in ECO	ECO
		When drive mode select switch position is in SNOW	SNOW
		When drive mode select switch position is in PERSONAL	STD
		A signal other than those above is input	ERROR
BSW/BSI WARN LMP	Ignition switch ON	When the BSW system is malfunctioning	On
		When the BSW system is normal	Off
BSI ON IND	Ignition switch ON	Blind Spot Intervention warning ON	On
		Blind Spot Intervention warning OFF	Off
BSW SYSTEM ON	Ignition switch ON	When the BSW system is ON	On
		When the BSW system is OFF	Off
BSI SYSTEM ON	Start the engine and press dynamic driver assistance switch (When Blind Spot Intervention system setting is ON)	When the Blind Spot Intervention system is ON	On
		When the Blind Spot Intervention system is OFF	Off
FCW SYSTEM ON	Engine running	When the FEB/PFCW system is ON	On
		When the FEB/PFCW system is OFF	Off
BCI SYSTEM ON	Engine running	When the BCI system is ON	On
		When the BCI system is OFF	Off
BATTERY CIRCUIT OFF	NOTE: The item is indicated, but not used		Off

A

B

C

D

E

F

G

H

I

J

K

L

M

N

CCS

P

ADAS CONTROL UNIT

< ECU DIAGNOSIS INFORMATION >

[ASCD]

Monitor item	Condition		Value/Status
LDP WARNING INDICATOR	Engine running	When the LDP system is malfunctioning	On
		When the LDP system is normal	Off
LDW ON INDICATOR	Ignition switch ON	LDW system display ON	On
		LDW system display OFF	Off
LDW WARNING INDICATOR	Ignition switch ON	When the LDW system is malfunctioning	On
		When the LDW system is normal	Off
SYSTEM CANCEL MESSAGE	Ignition switch ON	When the vehicle is normal	NOREQ
		When the wheel is slipping	SLIP
		When the drive mode selector is SNOW mode	SNOW
		When the VDC is OFF	VDC OFF
CAMERA HI TEMP MSG	Ignition switch ON	Lane camera unit high temperature warning display ON	On
		Lane camera unit high temperature warning display OFF	Off
ITS SETTING ITEM(DCA)	Ignition switch ON		On
ITS SETTING ITEM(LDP)	Ignition switch ON		On
ITS SETTING ITEM(BSI)	Ignition switch ON		On
BSI WARNING INDICATOR	Engine running	When the Blind Spot Intervention is malfunctioning	On
		When the Blind Spot Intervention is normal	Off
BSW ON INDICATOR	Ignition switch ON	BSW system display ON	On
		BSW system display OFF	Off
SIDE RADAR BLOCK COND	Ignition switch ON	Front bumper or side radar is dirty	On
		Front bumper and side radar is clean	Off
LDW WARNING ALERT TIMING	Ignition switch ON	LDW system OFF	Nothing
		Lane departure warning timing is early setting	Early
		Lane departure warning timing is late setting	Late
BSW IND BRIGHTNESS	Ignition switch ON	BSW system OFF	Nothing
		Blind Spot Warning/Blind Spot Intervention indicator brightness bright	Bright
		Blind Spot Warning/Blind Spot Intervention indicator brightness normal	Normal
		Blind Spot Warning/Blind Spot Intervention indicator brightness dark	Dark
SL MAIN SW	Engine running	When speed limiter MAIN switch is pressed	On
		When speed limiter MAIN switch is not pressed	Off
PMAS SW	NOTE: The item is indicated, but not used		—
PMAS IND	NOTE: The item is indicated, but not used		—
FUNC ITEM (FEB)	Engine running	"Forward Emergency Braking" set with the integral switch is ON	On
		"Forward Emergency Braking" set with the integral switch is OFF	Off
FEB SELECT	Ignition switch ON	"Forward Emergency Braking" set with the integral switch is ON	On
		"Forward Emergency Braking" set with the integral switch is OFF	Off

ADAS CONTROL UNIT

< ECU DIAGNOSIS INFORMATION >

[ASCD]

Monitor item	Condition		Value/Status
FEB SW	Engine running	FEB system ON	On
		FEB system OFF	Off
G SENSOR SIGNAL	NOTE: The item is indicated, but not used		—
PMAS BUZZER REQ 1	NOTE: The item is indicated, but not used		—
PMAS BUZZER REQ 2	NOTE: The item is indicated, but not used		—
PMAS BUZZER REQ 3	NOTE: The item is indicated, but not used		—
SL TARGET VEHICLE SPEED	While driving	When vehicle speed is set	Displays the set vehicle speed
SL SET LAMP	<ul style="list-style-type: none"> • Drive the vehicle and activate the speed limiter • Press speed limiter MAIN switch 	Speed limiter SET indicator ON	On
		Speed limiter SET indicator OFF	Off
SL LIMIT LAMP	<ul style="list-style-type: none"> • Drive the vehicle and activate the speed limiter • Press speed limiter MAIN switch 	Speed limiter system ON	On
		Speed limiter system OFF	Off
ASCD CANCEL (LOW SPEED)	Drive the vehicle and activate the ASCD	ASCD cancelled by low vehicle speed	On
		Other than above	Off
ASCD CANCEL (SPEED DIFF)	Drive the vehicle and activate the ASCD	ASCD cancelled by difference between set speed and vehicle speed	On
		Other than above	Off
KICK DOWN	Drive the vehicle and activate the speed limiter	When accelerator pedal is full depressed	On
		Other than above	Off

TERMINAL LAYOUT

PHYSICAL VALUES

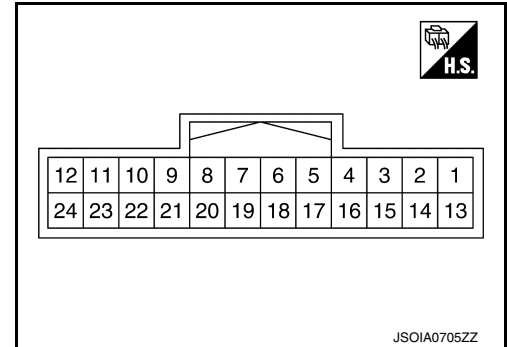

Terminal No. (Wire color)		Description		Condition	Standard value	Reference value
+	-	Signal name	Input/Output			
1 (L)	—	CAN -H	—	—	—	—
2 (R)	—	CAN -L	—	—	—	—
5 (B)	Ground	Ground	—	Ignition switch ON	0 - 0.1 V	Approx. 0 V

ADAS CONTROL UNIT

< ECU DIAGNOSIS INFORMATION >

[ASCD]

Terminal No. (Wire color)		Description		Condition		Standard value	Reference value
+	-	Signal name	Input/ Output				
6 (L)	—	ITS communication-H	—	—	—	—	—
7 (P)		ITS communication-L	—	—	—	—	—
8 (L)		Chassis communication-H	—	—	—	—	—
9 (R)		Chassis communication-L	—	—	—	—	—
12 (GR) ^{*1} (G) ^{*2}	5 (B)	Ignition power supply	Input	Ignition switch ON	—	10 - 16 V	Battery voltage
17 (V)		ICC brake hold relay drive signal	Output	Ignition switch ON	— At "STOP LAMP" test of "Active test"	10 - 16 V 0 - 0.1 V	Approx. 12 V Approx. 0 V
23 (Y)		ICC/ASCD steering switch signal ground	—	Ignition switch ON		0 - 0.1 V	Approx. 0 V
24 ^{*3} (SB)	23 ^{*3} (Y)	ICC steering switch signal	Input	Ignition switch ON	ICC steering switch: OFF	4.1 - 4.3 V	Approx. 4.3 V
					CANCEL switch: Pressed	1.1 - 1.6	Approx. 1.3 V
					RESUME/ACCELERATE switch: Pressed	3.5 - 3.7 V	Approx. 3.7 V
					SET/COAST switch: Pressed	2.8 - 3.1 V	Approx. 3.0 V
					DISTANCE switch: Pressed	2.0 - 2.4 V	Approx. 2.2 V
24 ^{*4} (SB)	23 ^{*4} (Y)	ASCD steering switch signal	Input	Ignition switch ON	ASCD steering switch: OFF	3.8 - 4.3 V	Approx. 4.0 V
					CANCEL switch: Pressed	0.8 - 1.3 V	Approx. 1.0 V
					SET/COAST switch: Pressed	1.8 - 2.2 V	Approx. 2.0 V
					RESUME/ACCELERATE switch: Pressed	2.8 - 3.1 V	Approx. 3.0 V

NOTE:

- *1: VR30DDTT
- *2: 2.0 TURBO GASOLINE ENGINE
- *3: Used only in with ICC.
- *4: Used only in without ICC.

Fail-safe (ADAS Control Unit)

INFOID:0000000013965375

If a malfunction occurs in each system, ADAS control unit cancels each control, sounds a beep, and turns ON the warning or indicator lamp.

ADAS CONTROL UNIT

< ECU DIAGNOSIS INFORMATION >

[ASCD]

System	Buzzer	Warning lamp/Warning display	Description
Vehicle-to-vehicle distance control mode	High-pitched tone	ICC system warning	Cancel
Conventional (fixed speed) cruise control mode	High-pitched tone	ICC system warning	Cancel
Forward Emergency Braking (FEB)	High-pitched tone	<ul style="list-style-type: none"> • FEB warning lamp • Warning systems indicator (Forward position: Yellow) 	Cancel
Predictive Forward Collision Warning (PFCW)	High-pitched tone	Warning systems indicator (Forward position: Yellow)	Cancel
Distance Control Assist (DCA)	High-pitched tone	Warning systems indicator (Forward position: Yellow)	Cancel
Blind Spot Warning (BSW)	—	Warning systems indicator (Blind spot position: Yellow)	Cancel
Back-up Collision Intervention (BCI)	High-pitched tone	BCI system warning	Cancel

DTC Inspection Priority Chart

INFOID:000000013965376

If multiple DTCs are detected simultaneously, check them one by one depending on the following DTC inspection priority chart.

Priority	Detected items (DTC)
1	<ul style="list-style-type: none"> • U1507: LOST COMM (SIDE RDR R) • U1508: LOST COMM (SIDE RDR L)
2	<ul style="list-style-type: none"> • C1A0A: CONFIG UNFINISHED • U1000: CAN COMM CIRCUIT • U1010: CONTROL UNIT (CAN)
3	<ul style="list-style-type: none"> • C1B00: CAMERA UNIT MALF • C1F02: APA C/U MALF • C1B53: SIDE RDR R MALF • C1B54: SIDE RDR L MALF • C1B84: DIST SEN MALFUNCTION

A
B
C
D
E
F
G
H
I
J
K
L
M
N
P



ADAS CONTROL UNIT

< ECU DIAGNOSIS INFORMATION >

[ASCD]

Priority	Detected items (DTC)	
4	<ul style="list-style-type: none"> • C1A01: POWER SUPPLY CIR • C1A02: POWER SUPPLY CIR 2 • C1A04: ABS/TCS/VDC CIRC • C1A05: BRAKE SW/STOP L SW • C1A06: OPERATION SW CIRC • C1A13: STOP LAMP RLY FIX • C1A14: ECM CIRCUIT • C1A24: NP RANGE • C1A26: ECD MODE MALF • C1A27: ECD PWR SUPPLY CIR • C1A33: CAN TRANSMISSION ERR • C1A34: COMMAND ERROR • C1A35: APA CIR • C1A36: APA CAN COMM CIR • C1A37: APA CAN CIR 2 • C1A38: APA CAN CIR 1 • C1A39: STRG SEN CIR • C1B01: CAM AIMING INCOMP • C1B03: CAM ABNRML TMP DETCT • C1B5D: FEB OPE COUNT LIMIT • C1B56: SONAR CIRCUIT • C1B59: CCM CIRCUIT • C1B82: DIST SEN OFF-CENTER • C1B85: DIST SEN ABNORMAL TEMP • C1F01: APA MOTOR MALF • C1F05: APA PWR SUPPLY CIR 	<ul style="list-style-type: none"> • U0121: VDC CAN CIR 2 • U0126: STRG SEN CAN CIR 1 • U0235: ICC SENSOR CAN CIRC 1 • U0401: ECM CAN CIR 1 • U0402: TCM CAN CIR 1 • U0415: VDC CAN CIR 1 • U0424: HVAC CAN CIR 1 • U0428: STRG SEN CAN CIR 2 • U1500: CAM CAN CIR 2 • U1501: CAM CAN CIR 1 • U1502: ICC SEN CAN COMM CIR • U1503: SIDE RDR L CAN CIR 2 • U1504: SIDE RDR L CAN CIR 1 • U1505: SIDE RDR R CAN CIR 2 • U1506: SIDE RDR R CAN CIR 1 • U150B: ECM CAN CIRC 3 • U150C: VDC CAN CIRC 3 • U150D: TCM CAN CIRC 3 • U150E: BCM CAN CIRC 3 • U150F: AV CAN CIRC 3 • U1512: HVAC CAN CIRC 3 • U1513: METER CAN CIRC 3 • U1514: STRG SEN CAN CIRC 3 • U1515: ICC SENSOR CAN CIRC 3 • U1516: CAM CAN CIRC 3 • U1517: APA CAN CIRC 3 • U1518: SIDE RDR L CAN CIRC 3 • U1519: SIDE RDR R CAN CIRC 3 • U1521: SONAR CAN COMMUNICATION 2 • U1522: SONAR CAN COMMUNICATION 1 • U1523: SONAR CAN COMMUNICATION 3 • U1524: AVM CAN COMMUNICATION 1 • U1525: AVM CAN COMMUNICATION 3 • U1527: CCM CAN CIR 1 • U153F: CCM CAN CIR 2 • U1530: DR ASSIST BUZZER CAN CIR 1 • U1540: DAST 3 CAN CIR 1 • U1541: DAST 3 CAN CIR 2
5	<ul style="list-style-type: none"> • C1A03: VHCL SPEED SE CIRC 	
6	<ul style="list-style-type: none"> • C1A15: GEAR POSITION 	
7	<ul style="list-style-type: none"> • C1A00: CONTROL UNIT 	

ADAS CONTROL UNIT

< ECU DIAGNOSIS INFORMATION >

[ASCD]

DTC Index

INFOID:000000013965377

Systems for fail-safe

- A: Vehicle-to-vehicle distance control mode
- B: Conventional (fixed speed) cruise control mode
- C: Distance Control Assist (DCA)
- D: Forward Emergency Braking (FEB)
- E: Predictive Forward Collision Warning (PFCW)
- F: Blind Spot Warning (BSW)/Blind Spot Intervention (Without Active Lane control)
- G: Back-up Collision Intervention (BCI)
- H: Lane Departure Warning (LDW)/Lane Departure Prevention (LDP)
- I: Automatic Speed Control Device (ASCD) (Without ICC)

DTC		CONSULT display	Fail-safe	Reference
CONSULT	On board display		System	
NO DTC IS DETECTED. FURTHER TESTING MAY BE REQUIRED	55	NO DTC IS DETECTED. FURTHER TESTING MAY BE REQUIRED	—	—
C1A0A	41	CONFIG UNFINISHED	A, B, C, D, E, F, G, H, I	DAS-153
C1A00	0	CONTROL UNIT	A, B, C, D, E, F, G, H, I	DAS-133
C1A01	1	POWER SUPPLY CIR	A, B, C, D, E, F, G, H, I	DAS-134
C1A02	2	POWER SUPPLY CIR 2	A, B, C, D, E, F, G, H, I	DAS-134
C1A03	3	VHCL SPEED SE CIRC	A, B, C, D, E, F, G, H, I	DAS-136
C1A04	4	ABS/TCS/VDC CIRC	A, B, C, D, E, F, G, H, I	DAS-138
C1A05	5	BRAKE SW/STOP L SW	A, B, C, D, F, G, H	DAS-140
C1A06	6	OPERATION SW CIRC	A, B, C, D, E, F, H, I	DAS-149
C1A13	13	STOP LAMP RLY FIX	A, B, C, D, E, G	DAS-154
C1A14	14	ECM CIRCUIT	A, B, C, D, E, I	DAS-166
C1A15	15	GEAR POSITION	A, B, C, D, E, I	DAS-168
C1A24	24	NP RANGE	A, B, C, D, E, F, H, G	DAS-171
C1A26	26	ECD MODE MALF	A, B, C, D, E, G	DAS-173
C1A27	27	ECD PWR SUPPLY CIR	A, B, C, D, E, G	DAS-175
C1A33	33	CAN TRANSMISSION ERR	A, B, C, D, E, I	DAS-177
C1A34	34	COMMAND ERROR	A, B, C, D, E, I	DAS-179
C1A35	35	APA CIR	A, C, D, E	DAS-181
C1A36	36	APA CAN COMM CIR	A, C, D, E	DAS-183
C1A37	133	APA CAN CIR 2	A, C, D, E	DAS-185
C1A38	132	APA CAN CIR 1	A, C, D, E	DAS-187
C1A39	39	STRG SEN CIR	A, B, C, D, E, F, G	DAS-189
C1B00	81	CAMERA UNIT MALF	F, H	DAS-191
C1B01	82	CAM AIMING INCOMP	F, H	DAS-192
C1B03	83	CAN ABNRML TMP DETCT	F, H	DAS-193
C1B5D	198	FEB OPE COUNT LIMIT	C, D, E	DAS-199
C1B53	84	SIDE RDR R MALF	F, G	DAS-194
C1B54	85	SIDE RDR L MALF	F, G	DAS-195
C1B56	86	SONAR CIRCUIT	G	DAS-196
C1B59	184	CCM CIRCUIT	A, B, C, F, G, H	DAS-197
C1B82	12	DIST SEN OFF-CENTER	A, C, D, E	DAS-200

A
B
C
D
E
F
G
H
I
J
K
L
M
N
P

CCS

ADAS CONTROL UNIT

< ECU DIAGNOSIS INFORMATION >

[ASCD]

Systems for fail-safe

- A: Vehicle-to-vehicle distance control mode
- B: Conventional (fixed speed) cruise control mode
- C: Distance Control Assist (DCA)
- D: Forward Emergency Braking (FEB)
- E: Predictive Forward Collision Warning (PFCW)
- F: Blind Spot Warning (BSW)/Blind Spot Intervention (Without Active Lane control)
- G: Back-up Collision Intervention (BCI)
- H: Lane Departure Warning (LDW)/Lane Departure Prevention (LDP)
- I: Automatic Speed Control Device (ASCD) (Without ICC)

DTC		CONSULT display	Fail-safe	Reference
CONSULT	On board display		System	
C1B84	17	DIST SEN MALFUNCTION	A, C, D, E	DAS-201
C1B85	21	DIST SEN ABNORMAL TEMP	A, C, D, E	DAS-202
C1F01	91	APA MOTOR MALF	A, C, D, E, G	DAS-203
C1F02	92	APA C/U MALF	A, C, D, E, G	DAS-204
C1F05	95	APA PWR SUPPLY CIR	A, C, D, E, G	DAS-205
U0121	127	VDC CAN CIR 2	A, B, C, D, E, F, G, H, I	DAS-207
U0126	130	STRG SEN CAN CIR 1	A, B, C, D, E, F, G	DAS-209
U0235	144	ICC SENSOR CAN CIRC 1	A, C, D, E	DAS-211
U0401	120	ECM CAN CIR 1	A, B, C, D, E, F, G, I	DAS-213
U0402	122	TCM CAN CIR 1	A, B, C, D, E, F, G, H	DAS-215
U0415	126	VDC CAN CIR 1	A, B, C, D, E, F, G, H, I	DAS-217
U0424	156	HVAC CAN CIR 1	—	DAS-219
U0428	131	STRG SEN CAN CIR 2	A, B, C, D, E, F, G	DAS-220
U1000 ^{NOTE}	100	CAN COMM CIRCUIT	A, B, C, D, E, F, G, H, I	DAS-222
U1010	110	CONTROL UNIT (CAN)	A, B, C, D, E, F, G, H, I	DAS-224
U150B	157	ECM CAN CIRC 3	A, B, C, D, E, F, G, H, I	DAS-225
U150C	158	VDC CAN CIRC 3	A, B, C, D, E, F, G, H, I	DAS-227
U150D	159	TCM CAN CIRC 3	A, B, C, D, E, F, G, H	DAS-229
U150E	160	BCM CAN CIRC 3	A, B, C, D, F, G, H	DAS-231
U150F	161	AV CAN CIRC 3	—	DAS-233
U1500	145	CAM CAN CIR2	F, H	DAS-234
U1501	146	CAM CAN CIR 1	F, H	DAS-236
U1502	147	ICC SEN CAN COMM CIR	A, C, D, E	DAS-238
U1503	150	SIDE RDR L CAN CIR 2	F, G	DAS-240
U1504	151	SIDE RDR L CAN CIR 1	F, G	DAS-242
U1505	152	SIDE RDR R CAN CIR 2	F, G	DAS-244
U1506	153	SIDE RDR R CAN CIR 1	F, G	DAS-246
U1507	154	LOST COMM (SIDE RDR R)	F, G	DAS-248
U1508	155	LOST COMM (SIDE RDR L)	F, G	DAS-250
U1512	162	HVAC CAN CIRC3	F, H	DAS-252
U1513	163	METER CAN CIRC 3	A, B, C, D, E, F, G, H, I	DAS-253
U1514	164	STRG SEN CAN CIRC 3	A, B, C, D, E, F, G	DAS-255
U1515	165	ICC SENSOR CAN CIRC 3	A, C, D, E	DAS-257
U1516	166	CAM CAN CIRC 3	F, H	DAS-259
U1517	167	APA CAN CIRC 3	A, C, D, E	DAS-261

ADAS CONTROL UNIT

< ECU DIAGNOSIS INFORMATION >

[ASCD]

Systems for fail-safe

- A: Vehicle-to-vehicle distance control mode
- B: Conventional (fixed speed) cruise control mode
- C: Distance Control Assist (DCA)
- D: Forward Emergency Braking (FEB)
- E: Predictive Forward Collision Warning (PFCW)
- F: Blind Spot Warning (BSW)/Blind Spot Intervention (Without Active Lane control)
- G: Back-up Collision Intervention (BCI)
- H: Lane Departure Warning (LDW)/Lane Departure Prevention (LDP)
- I: Automatic Speed Control Device (ASCD) (Without ICC)

DTC		CONSULT display	Fail-safe	Reference
CONSULT	On board display		System	
U1518	168	SIDE RDR L CAN CIRC 3	F, G	DAS-263
U1519	169	SIDE RDR R CAN CIRC 3	F, G	DAS-265
U1521	177	SONAR CAN COMMUNICATION 2	G	DAS-267
U1522	178	SONAR CAN COMMUNICATION 1	G	DAS-269
U1523	179	SONAR CAN COMMUNICATION 3	G	DAS-271
U1524	180	AVM CAN COMMUNICATION 1	G	DAS-273
U1525	181	AVM CAN COMMUNICATION 3	G	DAS-274
U1527	185	CCM CAN CIR1	A, B, C, F, G, H	DAS-276
U153F	186	CCM CAN CIR2	A, B, C, F, G, H	DAS-277
U1530	183	DR ASSIST BUZZER CAN CIR1	—	DAS-279
U1540	200	DAST 3 CAN CIR 1	C, D, E	DAS-280
U1541	201	DAST 3 CAN CIR 2	C, D, E	DAS-281

NOTE:

With the detection of “U1000” some systems do not perform the fail-safe operation.

A system controlling based on a signal received from the control unit performs fail-safe operation when the communication with the ADAS control unit becomes inoperable.

A
B
C
D
E
F
G
H
I
J
K
L
M
N
P



AUTOMATIC SPEED CONTROL DEVICE (ASCD)

[ASCD]

< WIRING DIAGRAM >

WIRING DIAGRAM

AUTOMATIC SPEED CONTROL DEVICE (ASCD)

Wiring Diagram

INFOID:000000013711902

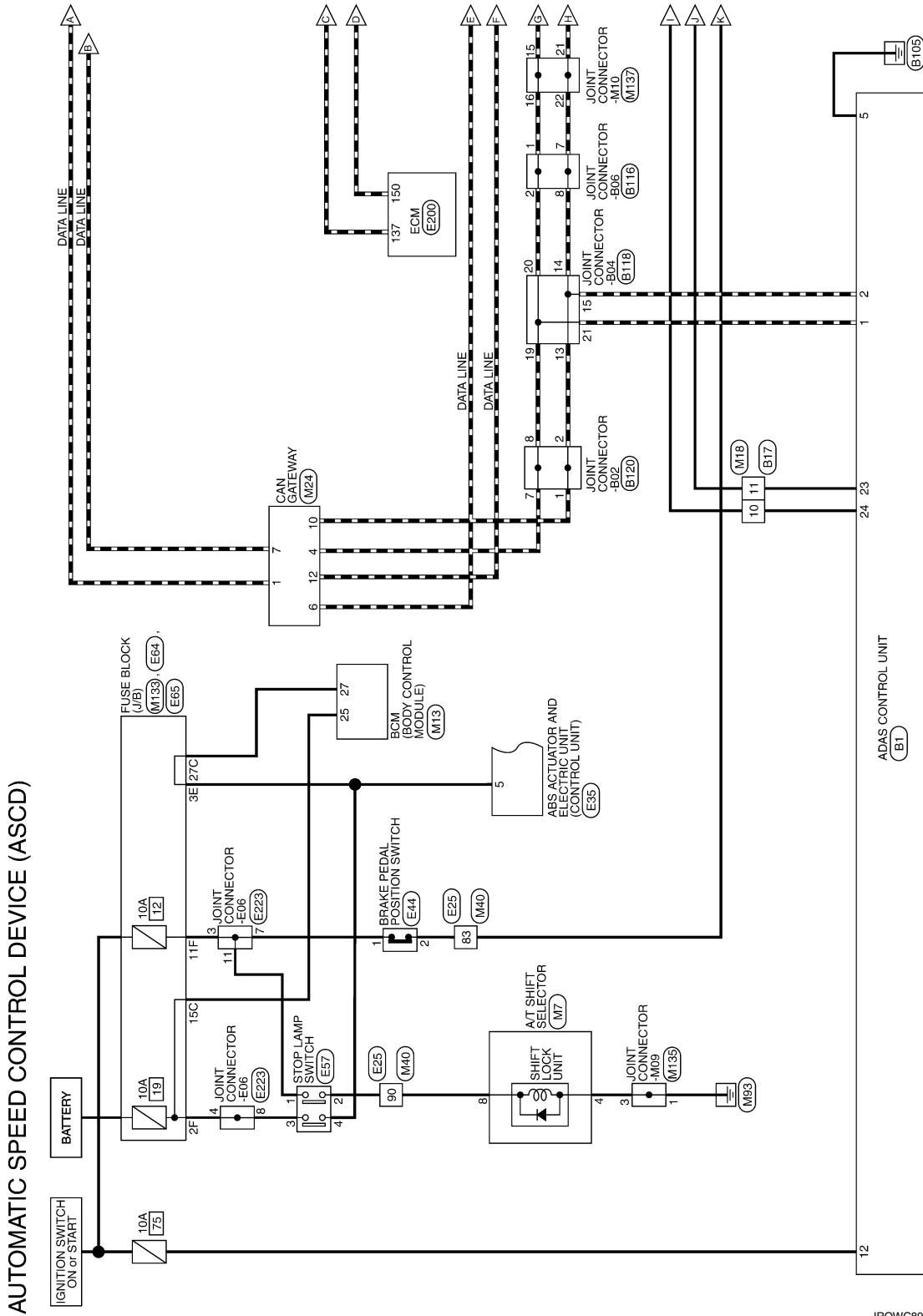

*: This connector is not shown in "Harness Layout".

2016/04/07

JROWC8983GB

AUTOMATIC SPEED CONTROL DEVICE (ASCD)

< WIRING DIAGRAM >

[ASCD]

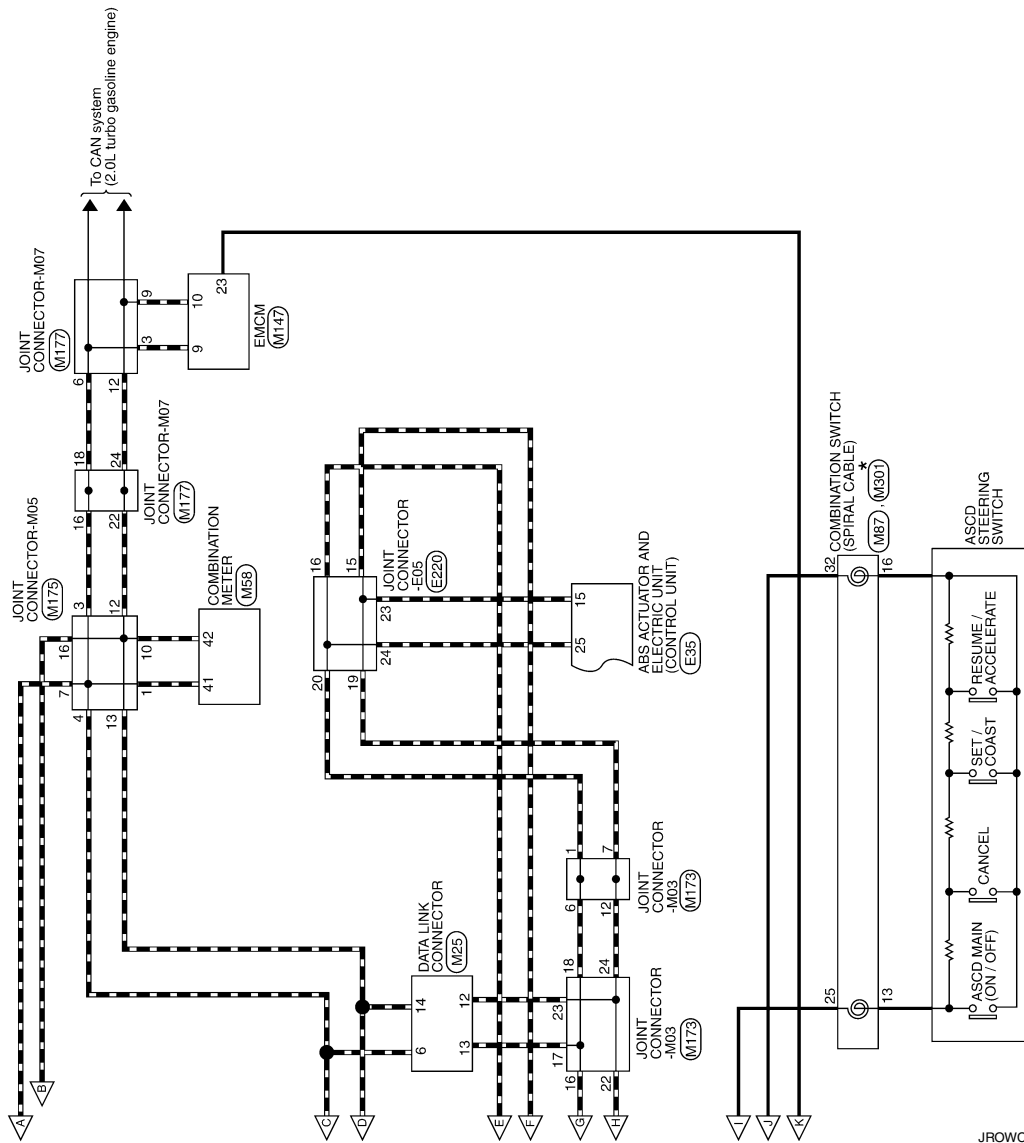

JROWC8984GB

A
B
C
D
E
F
G
H
I
J
K
L
M
N
P



AUTOMATIC SPEED CONTROL DEVICE (ASCD)

< WIRING DIAGRAM >

[ASCD]

AUTOMATIC SPEED CONTROL DEVICE (ASCD)

Connector No.	B1
Connector Name	ADAS CONTROL UNIT
Connector Type	TH24FW-NH



12	9	8	7	6	5	2	1
24	23	22	21	20	19	18	17

Terminal No.	Color Of Wire	Signal Name [Specification]
1	L	CAN-H
2	R	CAN-L
5	B	GROUND
6	L	ITS COMMUNICATION-H
7	P	ITS COMMUNICATION-L
8	L	CHASSIS COMMUNICATION-H
9	R	CHASSIS COMMUNICATION-L
12	G	IGNITION POWER SUPPLY [With 2.0L turbo gasoline engine]
12	GR	IGNITION POWER SUPPLY [With VR30 engine]
17	V	BRAKE HOLD RLY DRIVE SIGNAL
23	Y	STEERING SW SIGNAL GROUND
24	SB	STEERING SW SIGNAL

Connector No.	B17
Connector Name	WIRE TO WIRE
Connector Type	NS16FW-CS



7	6	5	4	3	2	1
16	15	14	13	12	11	10
9	8	7	6	5	4	3

Terminal No.	Color Of Wire	Signal Name [Specification]
10	SB	-
11	V	-
12	GR	-

Connector No.	B116
Connector Name	JOINT CONNECTOR-B06
Connector Type	24342_4GA2A



6	5	4	3	2	1
12	11	10	9	8	7
18	17	16	15	14	13
24	23	22	21	20	19

Terminal No.	Color Of Wire	Signal Name [Specification]
1	L	-
2	L	-
3	L	-
4	L	-
5	L	-
6	L	-
7	R	-
8	R	-
9	R	-
10	V	-
11	V	-
12	P	-
12	R	-
13	SHIELD	-
14	SHIELD	-
15	SHIELD	-
16	SHIELD	-
17	SHIELD	-
18	SHIELD	-
19	L	-
20	L	-
21	L	-
22	R	-
23	R	-
24	R	-

Connector No.	B118
Connector Name	JOINT CONNECTOR-B04
Connector Type	24342_4GA2A



6	5	4	3	2	1
12	11	10	9	8	7
18	17	16	15	14	13
24	23	22	21	20	19

Terminal No.	Color Of Wire	Signal Name [Specification]
1	LG	-
1	SHIELD	-
2	LG	-
2	SHIELD	-
3	LG	-
3	SHIELD	-
4	LG	-
4	SHIELD	-
5	LG	-
5	SHIELD	-
6	LG	-
6	SHIELD	-
7	LG	-
7	R	-
8	R	-
9	LG	-
9	R	-
10	LG	-
10	SHIELD	-
11	LG	-
11	SHIELD	-
12	LG	-
12	SHIELD	-
13	LL	-
13	R	-
14	R	-
14	R	-
15	L	-
15	R	-
16	L	-
17	L	-
18	L	-
19	SHIELD	-
20	L	-

20	SHIELD	-	[With VR30 engine]
21	L	-	[With 2.0L turbo gasoline engine]
21	SHIELD	-	[With VR30 engine]
22	R	-	-
23	R	-	-
24	R	-	-

Connector No.	B120
Connector Name	JOINT CONNECTOR-B02
Connector Type	24342_4GA2A



6	5	4	3	2	1
12	11	10	9	8	7
18	17	16	15	14	13
24	23	22	21	20	19

Terminal No.	Color Of Wire	Signal Name [Specification]
1	R	-
2	R	-
3	L	-
3	R	-
4	L	-
4	R	-
5	L	-
6	L	-
7	L	-
8	L	-
9	R	-
10	L	-
10	R	-
11	R	-
12	R	-
13	W	-
14	W	-
15	W	-
17	SHIELD	-
18	B	-
19	B	-
19	GR	-
20	GR	-
20	SHIELD	-
21	B	-
21	GR	-

AUTOMATIC SPEED CONTROL DEVICE (ASCD)

< WIRING DIAGRAM >

[ASCD]

AUTOMATIC SPEED CONTROL DEVICE (ASCD)

Connector No.	E57
Connector Name	STOP LAMP SWITCH
Connector Type	M04FW-LC



Terminal No.	Color Of Wire	Signal Name [Specification]
1	G	- [With ASCD]
1	L	- [With ADAS]
2	GR	- [With ASCD]
2	LG	- [With ADAS]
3	BR	-
4	V	-

Connector No.	E64
Connector Name	FUSE BLOCK (I/B)
Connector Type	NS08FW-CS



Terminal No.	Color Of Wire	Signal Name [Specification]
1E	G	-
2E	P	-
3E	V	-
4E	GR	-
6E	L	-
7E	BG	-

Connector No.	E65
Connector Name	FUSE BLOCK (I/B)
Connector Type	TH12FW-AH



Terminal No.	Color Of Wire	Signal Name [Specification]
10F	W	-
11F	G	- [With 2.0L turbo gasoline engine]
11F	R	- [With VFS0 engine]
12F	W	- [With VFS0 engine]
12F	Y	- [With 2.0L turbo gasoline engine]
1F	R	-
2F	BR	-
3F	P	-
5F	P	-
6F	L	-
7F	R	-
8F	L	-
9F	L	-

Connector No.	E200
Connector Name	ECM
Connector Type	ADA52FB-AH26



Terminal No.	Color Of Wire	Signal Name [Specification]
97	G	POWER SUPPLY (MAIN)
98	B	ECM GROUND
99	G	POWER SUPPLY (MAIN)
100	B	ECM GROUND
101	G	POWER SUPPLY (MAIN)
102	B	ECM GROUND
103	V	COOLING FAN CONTROL SIGNAL (PWM)

Terminal No.	Color Of Wire	Signal Name [Specification]
104	Y	SENSOR POWER SUPPLY
105	R	SENSOR POWER SUPPLY
106	W	SENSOR GROUND
109	P	ENGINE SPEED SIGNAL
111	G	POWER SUPPLY
116	LG	STARTER RELAY-L
119	BR	SENSOR GROUND
120	BG	SENSOR GROUND
123	BR	MAIN RELAY CONTROL SIGNAL
127	V	FUEL PUMP ON SIGNAL
132	G	ACCELERATOR PEDAL POSITION SENSOR 1
137	L	CON-L
138	L	DRIVETRAIN CAN-H
142	GR	BACK-UP LAMP SWITCH
143	LG	REFRIGERANT PRESSURE SENSOR
145	L	ACCELERATOR PEDAL POSITION SENSOR 2
146	L	FUEL TANK PRESSURE SENSOR
148	L	THROTTLE CONTROL MOTOR (CLOSE) [BANK 2] CAN-L
150	P	CAN-L
151	P	DRIVETRAIN CAN-L
152	B	EVAP CANISTER VENT CONTROL VALVE
153	G	EVAP PURGE CONTROL VALVE

Connector No.	E220
Connector Name	JOINT CONNECTOR-E05
Connector Type	NH24FB-J



Terminal No.	Color Of Wire	Signal Name [Specification]
2	W	-
3	W	-
4	W	-
7	W	-
8	L	-
15	R	-
16	L	-
19	R	-
20	L	-
23	R	-
24	L	-

Connector No.	E223
Connector Name	JOINT CONNECTOR-E06
Connector Type	SGA28FB-J



Terminal No.	Color Of Wire	Signal Name [Specification]
2	GR	-
3	G	-
4	BR	-
6	BG	-
7	G	-
8	BR	-
11	G	-
12	L	-
18	V	-
19	W	-
20	BG	-
22	GR	-
23	P	-
24	BR	-
26	V	-
27	W	-
28	BG	-

Connector No.	M7
Connector Name	A/T SHIFT SELECTOR
Connector Type	TH12FW-AH

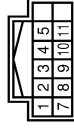

Terminal No.	Color Of Wire	Signal Name [Specification]
1	SB	-
2	GR	-
3	BG	-

AUTOMATIC SPEED CONTROL DEVICE (ASCD)

< WIRING DIAGRAM >

[ASCD]

AUTOMATIC SPEED CONTROL DEVICE (ASCD)

4	B	-	-
5	G	-	-
7	R	-	-
8	L	-	- [With VR30 engine]
8	V	-	- [With 2.0L turbo gasoline engine]
9	B	-	-
10	GR	-	-
11	R	-	-

Connector No.	M13
Connector Name	BCM (BODY CONTROL MODULE)
Connector Type	TH40PG-NH



Terminal No.	Color Of Wire	Signal Name [Specification]
1	R	PUSH SW
3	Y	SENS PWR SPLY
4	BG	OPTICAL SENSOR
5	LG	AIR BAG SIG
10	W	COMBI SW OUTPUT 5
11	SB	COMBI SW OUTPUT 4
12	L	COMBI SW OUTPUT 3
13	G	COMBI SW OUTPUT 2
14	P	COMBI SW OUTPUT 1
15	G	ONE TOUCH LINK SENS (DR)
16	G	ONE TOUCH LINK SENS (PASS)
17	P	RECEIVER/SENSOR GND
18	L	SECURITY IND LAMP CONT
20	R	DEFENT SW
21	SB	STEP LAMP CONT
23	R	STOP LAMP SW2
25	R	EXTENDED STORAGE FUSE SW
27	P	STOP LAMP SW
30	W	DR DOOR LINK SENS
33	V	TR LID OP CANCEL SW
36	G	HAZARD SW
39	BR	P/N POSITION

Connector No.	M18
Connector Name	WIRE TO WIRE
Connector Type	NS15AW-CS

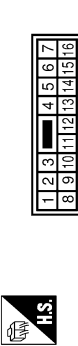

Terminal No.	Color Of Wire	Signal Name [Specification]
10	SB	-
11	Y	-
12	GR	-

Connector No.	M24
Connector Name	CAN GATEWAY
Connector Type	TH12FW-NH



Terminal No.	Color Of Wire	Signal Name [Specification]
1	L	CAN-H (CAN COMMUNICATION CIRCUIT 1)
2	W	BATTERY POWERS SUPPLY
3	W	CAN-H (CAN COMMUNICATION CIRCUIT 2)
4	L	GROUND
5	B	CAN-L (CAN COMMUNICATION CIRCUIT 2)
6	B	CAN-L (CAN COMMUNICATION CIRCUIT 1)
7	P	IGNITION POWER SUPPLY [With VR30 engine]
8	R	IGNITION POWER SUPPLY [With 2.0L turbo gasoline engine]
9	W	CAN-L (CAN COMMUNICATION CIRCUIT 2)
10	R	GROUND
11	B	CAN-L (CAN COMMUNICATION CIRCUIT 1)
12	R	CAN-L (CAN COMMUNICATION CIRCUIT 2)

Connector No.	M25
Connector Name	DATA LINK CONNECTOR
Connector Type	BD16FW



Terminal No.	Color Of Wire	Signal Name [Specification]
3	LG	M_CAN_L
4	B	EARTH
5	B	EARTH
6	L	CAN-H
7	V	K LINE [With 2.0L turbo gasoline engine]
7	W	K LINE [With VR30 engine]
8	W	IGN_SW
11	SB	M_CAN_H
12	R	CAN-L
13	L	CAN-H
14	P	CAN-L
16	W	POWER

Connector No.	M40
Connector Name	WIRE TO WIRE
Connector Type	TH80MW-CS16-TM4



Terminal No.	Color Of Wire	Signal Name [Specification]
1	BG	-
6	W/B	-
7	V	-
8	BG	- [With VR30 engine]
8	BR	- [With 2.0L turbo gasoline engine]
9	LG	- [With VR30 engine]
9	P	- [With 2.0L turbo gasoline engine]
10	W	-

Terminal No.	Color Of Wire	Signal Name [Specification]
11	W	- [With VR30 engine]
11	Y	- [With 2.0L turbo gasoline engine]
12	B	- [With VR30 engine]
12	BR	- [With 2.0L turbo gasoline engine]
13	GR	- [With VR30 engine]
13	GR	- [With 2.0L turbo gasoline engine]
13	SHIELD	- [With 2.0L turbo gasoline engine]
14	B	- [With 2.0L turbo gasoline engine]
15	BG	- [With 2.0L turbo gasoline engine]
15	SB	- [With VR30 engine]
16	B	- [With VR30 engine]
16	BR	- [With 2.0L turbo gasoline engine]
17	LG	-
18	B	- [With VR30 engine]
18	W/B	- [With 2.0L turbo gasoline engine]
19	Y	-
31	W	-
32	G	- [With 2.0L turbo gasoline engine]
32	V	- [With VR30 engine]
33	L	- [With VR30 engine]
33	Y	- [With 2.0L turbo gasoline engine]
34	P	-
35	BG	-
36	G	-
37	B	- [With VR30 engine]
37	L	- [With 2.0L turbo gasoline engine]
38	L	- [With VR30 engine]
38	R	- [With 2.0L turbo gasoline engine]
39	R	- [With 2.0L turbo gasoline engine]
39	Y	- [With VR30 engine]
40	GR	-
41	L	-
45	L	- [With 2.0L turbo gasoline engine]
45	W	- [With VR30 engine]
46	G	- [With VR30 engine]
46	Y	- [With 2.0L turbo gasoline engine]
47	BG	- [With 2.0L turbo gasoline engine]
47	R	- [With VR30 engine]
48	SHIELD	- [With VR30 engine]
49	B	- [With VR30 engine]
49	G	- [With 2.0L turbo gasoline engine]
50	B	- [With 2.0L turbo gasoline engine]
50	BR	- [With VR30 engine]
51	L	-
52	W	-
54	SB	- [With 2.0L turbo gasoline engine]
54	Y	- [With VR30 engine]
55	B	- [With 2.0L turbo gasoline engine]
55	P	- [With VR30 engine]
56	BG	- [With VR30 engine]
56	GR	- [With 2.0L turbo gasoline engine]

A B C D E F G H I J K L M N P

AUTOMATIC SPEED CONTROL DEVICE (ASCD)

< WIRING DIAGRAM >

[ASCD]

AUTOMATIC SPEED CONTROL DEVICE (ASCD)

57	GR	- [With VR30 engine]
57	P	- [With 2.0L turbo gasoline engine]
58	B	-
59	SB	-
61	W/B	-
64	Y	-
65	R	-
67	LG	-
68	BG	-
69	L	-
70	R	-
71	V	- [With VR30 engine]
71	W	- [With 2.0L turbo gasoline engine]
72	L	- [With 2.0L turbo gasoline engine]
73	LG	- [With VR30 engine]
73	R	- [With VR30 engine]
73	W	- [With 2.0L turbo gasoline engine]
74	BR	- [With VR30 engine]
74	L	- [With 2.0L turbo gasoline engine]
75	B	- [With VR30 engine]
75	R	- [With VR30 engine]
76	W/B	-
77	SB	-
78	G	- [With VR30 engine]
78	LG	- [With 2.0L turbo gasoline engine]
79	R	-
80	B	- [With VR30 engine]
80	G	- [With 2.0L turbo gasoline engine]
81	R	-
82	LG	-
83	BR	- [With 2.0L turbo gasoline engine]
83	R	- [With VR30 engine]
84	V	-
86	V	-
87	G	-
88	R	-
89	V	-
90	G	- [With VR30 engine]
90	V	- [With 2.0L turbo gasoline engine]
91	W	-
92	G	- [With VR30 engine]
92	W	- [With 2.0L turbo gasoline engine]
93	BR	-
94	L	- [With VR30 engine]
95	BR	- [With 2.0L turbo gasoline engine]
95	R	- [With VR30 engine]
96	W	-
97	LG	-
98	Y	-

99	BR	- [With VR30 engine]
99	LG	- [With 2.0L turbo gasoline engine]
100	SHIELD	-

Connector No.	M58
Connector Name	COMBINATION METER
Connector Type	TH12FW-NH



Terminal No.	Color Of Wire	Signal Name [Specification]
41	L	CAN-H
42	P	CAN-L
43	B	ILLUMINATION CONTROL SIGNAL
44	Y	FUEL LEVEL SENSOR GROUND
45	W	BATTERY POWER SUPPLY
46	BG	IGNITION SIGNAL [With 2.0L turbo gasoline engine models]
46	R	IGNITION SIGNAL [With VR30DDT engine models]
47	SB	AV COMMUNICATION SIGNAL (H)
48	LG	AV COMMUNICATION SIGNAL (L)
51	BR	FUEL LEVEL SENSOR SIGNAL
52	B	GROUND

Connector No.	M87
Connector Name	COMBINATIONS SWITCH (SPIRAL CABLE)
Connector Type	TI08FCV-TV



Terminal No.	Color Of Wire	Signal Name [Specification]
24	P	-
25	SB	-
31	W/B	-
32	Y	-

33	B	-
----	---	---

Connector No.	M133
Connector Name	FUSE BLOCK (I/B)
Connector Type	TH49FW-NH

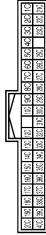

Terminal No.	Color Of Wire	Signal Name [Specification]
10C	V	-
12C	L	-
13C	L	-
14C	Y	-
15C	R	-
16C	R	-
17C	L	-
18C	BG	- [Without DRPO]
18C	P	- [With DRPO]
19C	B	-
1C	R	-
20C	W	-
21C	L	-
22C	L	-
23C	L	-
23C	LG	-
25C	SB	-
26C	P	-
27C	W	-
28C	W	-
29C	W	-
2C	R	-
30C	R	-
31C	W	-
32C	R	-
33C	B	- [With VR30 engine]
33C	R	- [With 2.0L turbo gasoline engine]
34C	W/B	-
35C	SB	-
36C	R	-
37C	W	-
38C	SB	-
39C	V	-
3C	P	-

40C	G	-
4C	P	-
5C	P	-
6C	G	-
7C	G	-
8C	G	-
9C	V	-

Connector No.	M135
Connector Name	JOINT CONNECTOR-M09
Connector Type	Z4342_4G62A

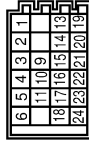

Terminal No.	Color Of Wire	Signal Name [Specification]
1	B	-
2	B	-
3	B	-
4	B	-
5	B	-
6	B	-
9	LG	-
10	LG	-
11	LG	-
13	B	- [With VR30 engine]
13	SB	- [With 2.0L turbo gasoline engine]
14	B	- [With VR30 engine]
14	SB	- [With 2.0L turbo gasoline engine]
15	B	- [With VR30 engine]
15	SB	- [With 2.0L turbo gasoline engine]
16	SB	- [With 2.0L turbo gasoline engine]
16	Y	- [With VR30 engine]
17	SB	- [With 2.0L turbo gasoline engine]
17	F	- [With VR30 engine]
18	SB	- [With 2.0L turbo gasoline engine]
18	Y	- [With VR30 engine]
19	SHIELD	-
20	R	-
21	R	-
22	SHIELD	-
23	L	-
24	L	-

AUTOMATIC SPEED CONTROL DEVICE (ASCD)

< WIRING DIAGRAM >

[ASCD]

AUTOMATIC SPEED CONTROL DEVICE (ASCD)

Connector No.	M137
Connector Name	JOINT CONNECTOR-M10
Connector Type	24342_4GAZA

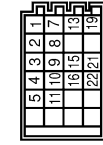

Terminal No.	Color Of Wire	Signal Name [Specification]
1	B	-
2	B	-
3	B	-
4	B	-
5	B	-
7	B	-
8	B	-
9	B	-
10	B	-
11	B	-
13	L	-
15	L	-
16	L	-
19	R	-
21	R	-
22	R	-

Connector No.	M147
Connector Name	EMCM
Connector Type	RH401ER-28-RL1HZ

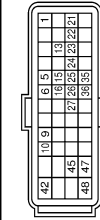

Terminal No.	Color Of Wire	Signal Name [Specification]
1	Y	EMCM RELAY CONTROL (SSOFF)
5	L	IGNITION SWITCH
6	LG	STOP LAMP SWITCH
9	L	CAN-H

Terminal No.	Color Of Wire	Signal Name [Specification]
10	P	CAN-L
13	W	STOP/START OFF SWITCH
15	Y	ENGINE POWER SUPPLY MAIN BATTERY CURRENT (TEMPERATURE SENSOR)
16	W	ENGINE POWER SUPPLY SUB BATTERY CURRENT (TEMPERATURE SENSOR)
21	V	SUB BATTERY RELAY CONTROL
22	G	ENGINE RESTART BYPASS CONTROL RELAY
23	G	ENGINE RESTART BYPASS CONTROL RELAY
24	GR	MAIN BATTERY CURRENT SENSOR
25	RG	MAIN BATTERY TEMPERATURE SENSOR
26	RR	SUB BATTERY CURRENT SENSOR
27	RR	SUB BATTERY TEMPERATURE SENSOR
35	SB	ENGINE POWER SUPPLY MAIN BATTERY CURRENT (TEMPERATURE SENSOR)
36	G	ENGINE POWER SUPPLY SUB BATTERY CURRENT (TEMPERATURE SENSOR)
42	G	EMCM POWER SUPPLY
45	R	SUB BATTERY VOLTAGE MONITOR
47	B	EMCM GROUND
48	B	EMCM GROUND

Connector No.	M173
Connector Name	JOINT CONNECTOR-M03
Connector Type	24342_4GAZA

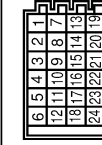

Terminal No.	Color Of Wire	Signal Name [Specification]
1	L	-
2	L	-
3	L	-
4	L	-
5	L	-
6	L	-
7	R	-
8	R	-
9	R	-
10	R	-
11	R	-
12	R	-
13	SB	-
14	SB	-
15	SB	-
16	L	- [With 2.0L turbo gasoline engine]
16	SB	- [With VR30 engine]

Terminal No.	Color Of Wire	Signal Name [Specification]
17	L	- [With 2.0L turbo gasoline engine]
17	SB	- [With VR30 engine]
18	L	- [With 2.0L turbo gasoline engine]
18	SB	- [With VR30 engine]
19	BR	- [With VR30 engine]
20	BR	- [With 2.0L turbo gasoline engine]
20	BR	- [With VR30 engine]
20	LG	- [With 2.0L turbo gasoline engine]
21	BR	- [With VR30 engine]
21	LG	- [With 2.0L turbo gasoline engine]
22	R	- [With 2.0L turbo gasoline engine]
22	SB	- [With VR30 engine]
23	R	- [With 2.0L turbo gasoline engine]
23	SB	- [With VR30 engine]
24	R	- [With 2.0L turbo gasoline engine]
24	SB	- [With VR30 engine]

Connector No.	M175
Connector Name	JOINT CONNECTOR-M05
Connector Type	NH20FL-PC

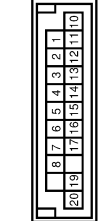

Terminal No.	Color Of Wire	Signal Name [Specification]
1	L	-
2	L	-
3	L	-
4	L	-
5	L	-
6	L	-
7	L	-
8	L	-
10	P	-
11	P	-
12	P	-
13	P	-
14	P	-
15	P	-
16	P	-
17	P	-
19	W	-
20	W	-

Connector No.	M177
Connector Name	JOINT CONNECTOR-M07
Connector Type	24342_4GAZA

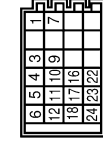

Terminal No.	Color Of Wire	Signal Name [Specification]
1	L	-
3	L	-
4	L	-
5	L	-
6	L	-
7	P	-
9	P	-
10	P	-
11	P	-
12	P	-
16	L	-
17	L	-
18	L	-
22	P	-
23	P	-
24	P	-

Connector No.	M301
Connector Name	COMBINATION SWITCH (SPIRAL CABLE)
Connector Type	TK08FGY



Terminal No.	Color Of Wire	Signal Name [Specification]
13	-	-
14	-	-
14	-	-
15	-	-
15	-	-
16	-	-

A
B
C
D
E
F
G
H
I
J
K
L
M
N
P



AUTOMATIC SPEED CONTROL DEVICE (ASCD)

< WIRING DIAGRAM >

[ASCD]

AUTOMATIC SPEED CONTROL DEVICE (ASCD)

17	-	-
18	-	-
19	-	-
20	-	-

JROWC8991GB

DIAGNOSIS AND REPAIR WORK FLOW

< BASIC INSPECTION >

[ASCD]

BASIC INSPECTION

DIAGNOSIS AND REPAIR WORK FLOW

Work Flow

INFOID:000000013711903

OVERALL SEQUENCE

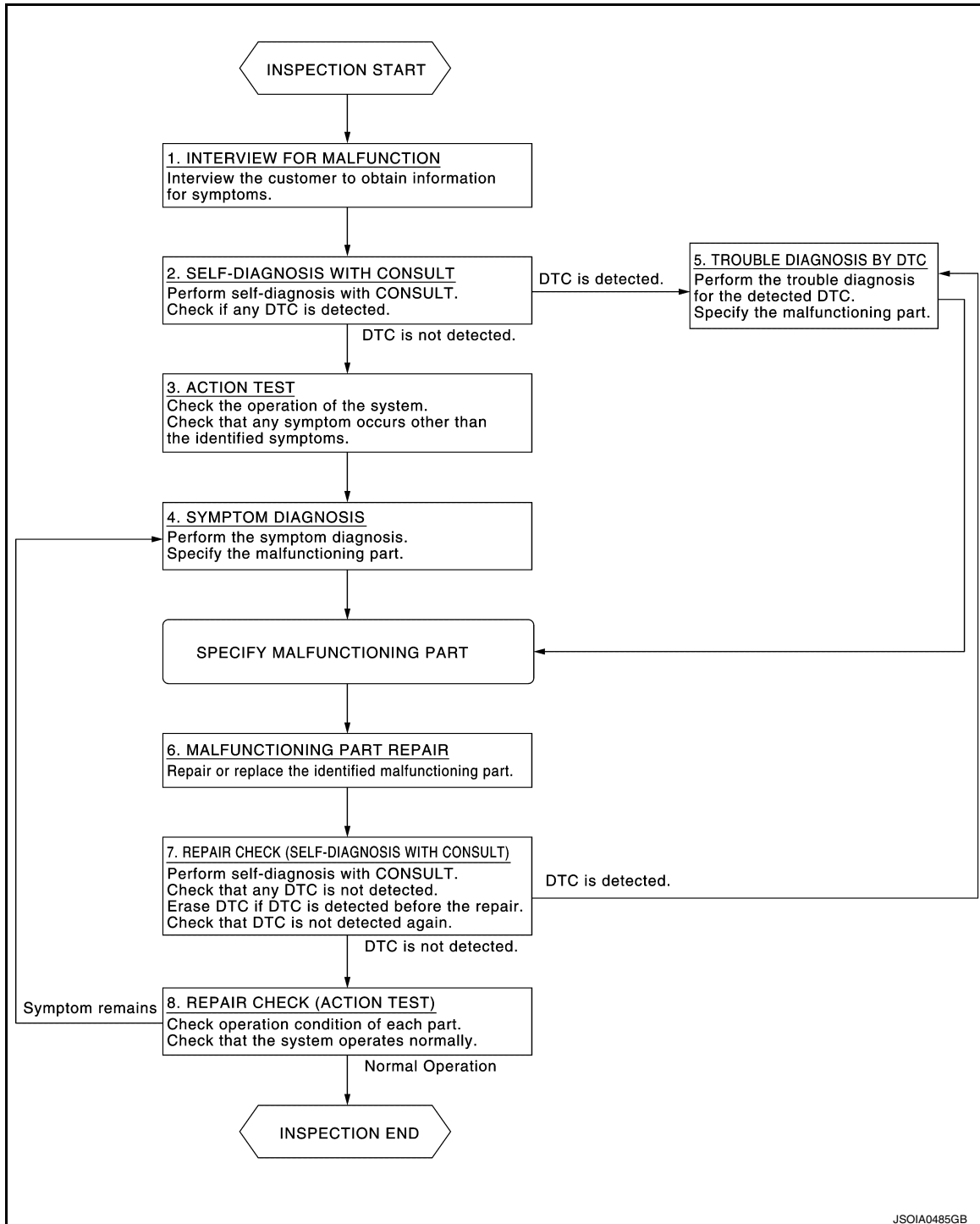

DETAILED FLOW

1. INTERVIEW FOR MALFUNCTION

It is also important to clarify the customer concerns before starting the inspection. Interview the customer about the concerns carefully and understand the symptoms fully.

NOTE:

A
B
C
D
E
F
G
H
I
J
K
L
M
N
P

CCS

DIAGNOSIS AND REPAIR WORK FLOW

[ASCD]

< BASIC INSPECTION >

The customers are not professionals. Never assume that “maybe the customer means…” or “maybe the customer mentioned this symptom”.

>> GO TO 2.

2. SELF-DIAGNOSIS WITH CONSULT

1. Perform “All DTC Reading” with CONSULT.
2. Check if any DTC is detected in self-diagnosis results of “ICC/ADAS”.

Is any DTC detected?

- YES >> GO TO 5.
NO >> GO TO 3.

3. ACTION TEST

Perform the ASCD system action test to check the operation status. Refer to [CCS-243, "Description"](#).
Check if any other malfunctions occur.

>> GO TO 4.

4. SYMPTOM DIAGNOSIS

Perform the applicable diagnosis according to the diagnosis chart by symptom. Refer to [CCS-245, "Symptom Table"](#).

>> GO TO 6.

5. TROUBLE DIAGNOSIS BY DTC

1. Check the DTC in the self-diagnosis results.
2. Perform trouble diagnosis for the detected DTC. Refer to [DAS-67, "DTC Index"](#) (ICC/ADAS).

NOTE:

If “DTC: U1000” is detected, first diagnose the CAN communication system.

>> GO TO 6.

6. MALFUNCTIONING PART REPAIR

Repair or replace the identified malfunctioning parts.

>> GO TO 7.

7. REPAIR CHECK (SELF-DIAGNOSIS WITH CONSULT)

1. Erases self-diagnosis results.
2. Perform “All DTC Reading” again after repairing or replacing the malfunctioning parts.
3. Check if any DTC is detected in self-diagnosis results of “ICC/ADAS”.

Is any DTC detected?

- YES >> GO TO 5.
NO >> GO TO 8.

8. REPAIR CHECK (ACTION TEST)

Perform the ASCD system action test. Check if the malfunction symptom is solved or no other symptoms occur.

Is there any malfunction symptom?

- YES >> GO TO 4.
NO >> INSPECTION END

ACTION TEST

< BASIC INSPECTION >

[ASCD]

ACTION TEST

Description

INFOID:0000000013711904

Always perform the ASCD system action test to check that the ASCD system operates normally after repairing any ASCD system malfunction. Refer to [CCS-243, "Work Procedure \[Automatic Speed Control Device \(ASCD\)\]"](#).

CAUTION:

Always drive safely when performing the action test.

Work Procedure [Automatic Speed Control Device (ASCD)]

INFOID:0000000013711905

NOTE:

The running speed can be set between 40 km/h (25 MPH) and 144 km/h (90 MPH)

CAUTION:

Never set the cruise speed exceeding the posted speed limit.

1. CHECK FOR ASCD MAIN SWITCH

1. Start the engine.
2. Press the ASCD MAIN switch
3. Check that the ASCD system display on the information display turns ON and the display is ready for activation.
4. Press the ASCD MAIN switch, and check that the ASCD system display on the information display turns OFF when the ASCD system is deactivated.
5. Check that the ASCD system display on the information display turns OFF after starting the engine again.

>> GO TO 2.

2. CHECK FOR RESUME/ACCELERATE, SET/COAST, AND CANCEL SWITCHES

1. Check that RESUME/ACCELERATE, SET/COAST, CANCEL switches are operated smoothly.
2. Check that switches come up as hand is released from the switches.

>> GO TO 3.

3. SET CHECKING

1. Start the engine.
2. Press the ASCD MAIN switch and turn the ASCD to ON.
3. Drive the vehicle at 40 km/h (25 MPH) or more.
4. Push down the SET/COAST switch.
5. Check that the desired speed is set and ASCD control starts when releasing SET/COAST switch.

NOTE:

Display the set status in the ASCD system display on the information display.

>> GO TO 4.

4. CHECK FOR INCREASE OF CRUISING SPEED

1. Set the vehicle speed to any desired speed, and drive the vehicle.
2. Check that the set speed increases by 1.6 km/h (1 MPH) as RESUME/ACCELERATE switch is pushed up.

NOTE:

- The maximum set speed is 144 km/h (90 MPH).
- The set vehicle speed increases while pushing up the RESUME/ACCELERATE switch.

CAUTION:

Never set the cruise speed exceeding the posted speed limit.

>> GO TO 5.

5. CHECK FOR DECREASE OF CRUISING SPEED

1. Set the vehicle speed to any desired speed, and drive the vehicle.

A
B
C
D
E
F
G
H
I
J
K
L
M
N
P

ACTION TEST

< BASIC INSPECTION >

[ASCD]

2. Check that the set speed decreases by 1.6 km/h (1 MPH) as SET/COAST switch is pushed down.

NOTE:

- The minimum set speed is 40 km/h (25 MPH).
- The set vehicle speed decreases while pressing down the SET/COAST switch.

>> GO TO 6.

6. CHECK FOR CANCELLATION OF ASCD

Check that the ASCD is canceled when performing the following operations.

- When the brake pedal is depressed after the ASCD is set and the vehicle is driven.
- When the selector lever is in the "N" position after the ASCD is set and the vehicle is driven.
- When the ASCD MAIN switch is turned OFF after the ASCD is set and the vehicle is driven.
- When the CANCEL switch is pressed after the ASCD is set and the vehicle is driven.

>> GO TO 7.

7. CHECK FOR RESTORING SPEED THAT IS SET BY ASCD BEFORE CANCELLATION

Check that the vehicle restores the previous speed kept before the system deactivation when performing the following operations.

- Drive the vehicle when the ASCD is set and depress the brake pedal to cancel the control. Check that the vehicle restores the previous vehicle speed kept before the system deactivation when pushing up the RESUME/ACCELERATE switch at the vehicle speed approximately 40 km/h (25 MPH) or more.
- Drive the vehicle when the ASCD is set and shift the selector lever is in the "N" position to cancel the control. Check that the vehicle restores the previous vehicle speed kept before the system deactivation when shifting the selector lever is in the "D" position and pushing up the RESUME/ACCELERATE switch at the vehicle speed of approximately 40 km/h (25 MPH) or more.
- Drive the vehicle when the ASCD is set and press the CANCEL switch to cancel the control. Check that the vehicle restores the previous vehicle speed kept before the system deactivation when pushing up the RESUME/ACCELERATE switch at the vehicle speed of approximately 40 km/h (25 MPH) or more.

>> INSPECTION END

AUTOMATIC SPEED CONTROL DEVICE (ASCD) SYMPTOMS

< SYMPTOM DIAGNOSIS >

[ASCD]

SYMPTOM DIAGNOSIS

AUTOMATIC SPEED CONTROL DEVICE (ASCD) SYMPTOMS

Symptom Table

INFOID:0000000013711906

Symptoms		Reference page
Operation	MAIN switch does not turn ON	Refer to CCS-246, "Description"
	MAIN switch does not turn OFF	
	System cannot be set (MAIN switch turns ON/OFF)	Refer to CCS-247, "Description"
	CANCEL switch does not function	Refer to CCS-249, "Description"
	Resume does not function	
	Set speed does not increase	
	ASCD is not canceled when the A/T selector lever is "N" position	Refer to CCS-250, "Description"
Display	System display not appear	Refer to MWI-72, "On Board Diagnosis Function"
Control	Driving force is hunting	Refer to CCS-251, "Description"

A
B
C
D
E
F
G
H
I
J
K
L
M
N
P



MAIN SWITCH DOES NOT TURN ON, MAIN SWITCH DOES NOT TURN OFF

< SYMPTOM DIAGNOSIS >

[ASCD]

MAIN SWITCH DOES NOT TURN ON, MAIN SWITCH DOES NOT TURN OFF

Description

INFOID:000000013711907

MAIN switch does not turn ON

- ASCD system display does not appear even when MAIN switch is pressed.

MAIN switch does not turn OFF

- When system display is ON, display does not turn OFF even if ASCD MAIN switch is pressed.

NOTE:

When system malfunction illuminates, perform the self-diagnosis of system, and then repair or replace the malfunctioning parts.

Diagnosis Procedure

INFOID:000000013711908

1.MAIN SWITCH INSPECTION

1. Start the engine.
2. Check that "MAIN SW" and "CRUISE LAMP" operate normally in "DATA MONITOR" of "ICC/ADAS" with CONSULT.

Is the inspection result normal?

YES >> GO TO 2.

NO >> GO TO 4.

2.CHECK COMBINATION METER

Check that "CRUISE IND" operates normally in "DATA MONITOR" of "METER/M&A".

Is the inspection result normal?

YES >> GO TO 3.

NO >> GO TO 4.

3.PERFORM SELF-DIAGNOSIS OF COMBINATION METER

1. Perform "Self Diagnostic Result" of "METER/M&A".
2. Check if DTC is detected. Refer to [MWI-91, "DTC Index"](#).

Is any DTC detected?

YES >> Repair or replace malfunctioning parts.

NO >> GO TO 4.

4.PERFORM SELF-DIAGNOSIS RESULTS OF SYSTEM

1. Perform "All DTC Reading".
2. Check if the "U1000" is detected in self-diagnosis results of "ICC/ADAS".

Is "U1000" detected?

YES >> GO TO 5.

NO >> GO TO 6.

5.CAN COMMUNICATIONS INSPECTION

Check the CAN communication and repair or replace malfunctioning parts. Refer to [DAS-222, "ADAS CONTROL UNIT : DTC Description"](#).

>> INSPECTION END

6.CHECK ASCD STEERING SWITCH

Check the ASCD steering switch. Refer to [DAS-152, "ADAS CONTROL UNIT : Component Inspection \(Without ICC\)"](#).

>> INSPECTION END

SYSTEM CANNOT BE SET (MAIN SWITCH TURNS ON/OFF)

< SYMPTOM DIAGNOSIS >

[ASCD]

SYSTEM CANNOT BE SET (MAIN SWITCH TURNS ON/OFF)

Description

INFOID:0000000013711909

The MAIN switch can be turned ON/OFF, but the ASCD system cannot be set even if the SET/COAST switch is pressed.

NOTE:

The system cannot be set in the following case.

- When the vehicle ahead is not detected below the speed of 32 km/h (20 MPH).
- When the selector lever is not in the “D” position or manual mode.
- When the shift lever is in the neutral position.
- When the brake pedal is depressed.
- When the clutch pedal is depressed.
- When the VDC is turned OFF.
- When ABS or VDC (including the TCS) operates.
- When a wheel slips.
- When ABS warning lamp is ON.
- When drive mode select switch is in SNOW position.

Diagnosis Procedure

INFOID:0000000013711910

1. CHECK CAUSE OF AUTOMATIC CANCELLATION

Check if there is the cancellation cause in the “CAUSE OF AUTO-CANCEL” on “WORK SUPPORT” of “ICC/ADAS” with CONSULT.

Is it displayed?

Not displayed >> GO TO 2.

“OPE SW VOLT CIRC” >> Refer to [DAS-149, "ADAS CONTROL UNIT : DTC Description"](#).

“VHCL SPD UNMATCH” >> Refer to [DAS-136, "ADAS CONTROL UNIT : DTC Description"](#).

“IGN LOW VOLT” >> Refer to [DAS-134, "ADAS CONTROL UNIT : DTC Description"](#).

“ECM CIRCUIT” >> Refer to [DAS-166, "ADAS CONTROL UNIT : DTC Description"](#).

“CAN COMM ERROR” >> Refer to [DAS-222, "ADAS CONTROL UNIT : DTC Description"](#).

“ABS/TCS/VDC CIRC” >> Refer to [DAS-138, "ADAS CONTROL UNIT : DTC Description"](#).

“ECD CIRCUIT” >> Refer to [DAS-173, "ADAS CONTROL UNIT : DTC Description"](#).

2. PERFORM THE SELF-DIAGNOSIS

1. Perform “All DTC Reading”.
2. Check if any DTC is detected in “Self Diagnostic Result” of “ICC/ADAS”. Refer to [DAS-67, "DTC Index" \(ICC/ADAS\)](#).

Is any DTC detected?

YES >> GO TO 3.

NO >> GO TO 4.

3. REPAIR OR REPLACE MALFUNCTIONING PARTS

Repair or replace malfunctioning parts identified by the self-diagnosis result.

>> GO TO 6.

4. CHECK EACH SWITCH AND VEHICLE SPEED SIGNAL

1. Start the engine.
2. Check that the following items operate normally in “DATA MONITOR” of “ICC/ADAS”.
 - “VHCL SPEED SE”
 - “D RANGE SW”
 - “SET/COAST SW”
 - “BRAKE SW”
 - “PKB SW”

Is there a malfunctioning item?

All items are normal >> GO TO 5.

“VHCL SPEED SE” >> Refer to [DAS-136, "ADAS CONTROL UNIT : DTC Description"](#).

“D RANGE SW” >> Refer to [CCS-250, "Diagnosis Procedure"](#).

A

B

C

D

E

F

G

H

I

J

K

L

M

N

CCS

P

SYSTEM CANNOT BE SET (MAIN SWITCH TURNS ON/OFF)

< SYMPTOM DIAGNOSIS >

[ASCD]

“SET/COAST SW”>>Refer to [DAS-149, "ADAS CONTROL UNIT : DTC Description"](#).

“BRAKE SW”>>Refer to [DAS-140, "ADAS CONTROL UNIT : DTC Description"](#).

“PKB SW”>>Refer to [WCS-62, "Diagnosis Procedure"](#).

5.REPLACE ADAS CONTROL UNIT

Replace the ADAS control unit. Refer to [DAS-352, "Removal and Installation"](#).

>> GO TO 6.

6.CHECK AUTOMATIC SPEED CONTROL DEVICE (ASCD) SYSTEM

-
1. Erase the self-diagnosis results, and then perform “All DTC Reading” again after performing the action test. (Refer to [CCS-243, "Description"](#) for action test.)
 2. Check that the ASCD system is normal.

>> INSPECTION END

STEERING SWITCH (OTHER THAN MAIN SWITCH) DOES NOT FUNCTION

< SYMPTOM DIAGNOSIS >

[ASCD]

STEERING SWITCH (OTHER THAN MAIN SWITCH) DOES NOT FUNCTION

Description

INFOID:0000000013711911

MAIN switch can be turned ON/OFF, but the operation of RESUME/ACCELERATE switch and CANCEL switch cannot be performed during ASCD system operation.

NOTE:

Resume is not accepted when the following condition is met.

- When the MAIN switch is turned OFF once.

Diagnosis Procedure

INFOID:0000000013711912

1. CHECK EACH SWITCH

1. Start the engine.
2. Check that each switch operates normally on "DATA MONITOR" of "ICC/ADAS" with CONSULT.
 - "RESUME/ACC SW"
 - "CANCEL SW"

Is the inspection result normal?

YES >> GO TO 5.

NO >> GO TO 2.

2. PERFORM ALL OF THE SELF-DIAGNOSIS ITEMS

1. Perform "All DTC Reading".
2. Check if the "U1000" is detected in "Self Diagnostic Result" of "ICC/ADAS".

Is "U1000" detected?

YES >> GO TO 3.

NO >> GO TO 4.

3. CAN COMMUNICATIONS INSPECTION

Check the CAN communication and repair or replace malfunctioning parts. Refer to [DAS-222, "ADAS CONTROL UNIT : DTC Description"](#).

>> INSPECTION END

4. CHECK ASCD STEERING SWITCH

Check the ASCD steering switch. Refer to [DAS-152, "ADAS CONTROL UNIT : Component Inspection \(Without ICC\)"](#).

>> GO TO 6.

5. REPLACE ADAS CONTROL UNIT

Replace the ADAS control unit. Refer to [DAS-352, "Removal and Installation"](#).

>> GO TO 6.

6. CHECK ASCD SYSTEM

1. Erase the self-diagnosis results, and then perform "All DTC Reading" again after performing the action test. (Refer to [CCS-243, "Description"](#) for action test.)
2. Check that the ASCD system is normal.

>> INSPECTION END

SYSTEM DOES NOT CANCEL WHEN A/T SELECTOR LEVER SETS ON "N"

< SYMPTOM DIAGNOSIS >

[ASCD]

SYSTEM DOES NOT CANCEL WHEN A/T SELECTOR LEVER SETS ON "N"

Description

INFOID:000000013711913

The ASCD system is not canceled even when the A/T selector lever is shifted to the N position while the ASCD system is active.

Diagnosis Procedure

INFOID:000000013711914

1. CHECK D RANGE SWITCH

Check if "D RANGE SW" operates normally in "DATA MONITOR" of "ICC/ADAS" with CONSULT.

Is the inspection result normal?

- YES >> GO TO 6.
- NO >> GO TO 2.

2. PERFORM ALL SELF-DIAGNOSIS ITEMS

1. Perform "All DTC Reading".
2. Check if the "U1000" is detected in "self-diagnosis results" of "ICC/ADAS".

Is "U1000" detected?

- YES >> GO TO 3.
- NO >> GO TO 4.

3. CAN COMMUNICATIONS INSPECTION

Check the CAN communication and repair or replace malfunctioning parts. Refer to [DAS-222, "ADAS CONTROL UNIT : DTC Description"](#).

>> INSPECTION END

4. CHECK POSITION SWITCH

Check if "POSI OF SELECT RANGE VALV" operates normally in "DATA MONITOR" of "TRANSMISSION".

Is the inspection result normal?

- YES >> GO TO 6.
- NO >> GO TO 5.

5. PERFORM TCM SELF-DIAGNOSIS

1. Perform the "Self Diagnostic Result" of "TRANSMISSION".
2. Repair or replace malfunctioning parts. Refer to [TM-102, "2.0L TURBO GASOLINE ENGINE : DTC Index"](#).

>> GO TO 7.

6. REPLACE ADAS CONTROL UNIT

Replace the ADAS control unit. Refer to [DAS-352, "Removal and Installation"](#).

>> GO TO 7.

7. CHECK ASCD SYSTEM

1. Erase the self-diagnosis results, and then perform "All DTC Reading" again after performing the action test. (Refer to [CCS-250, "Description"](#) for action test.)
2. Check that the ASCD system is normal.

>> INSPECTION END

DRIVING FORCE IS HUNTING

< SYMPTOM DIAGNOSIS >

[ASCD]

DRIVING FORCE IS HUNTING

Description

INFOID:0000000013711915

The vehicle causes hunting when the ASCD system is active.

Diagnosis Procedure

INFOID:0000000013711916

1.PERFORM SELF-DIAGNOSIS OF ECM/EMCM

1. Perform "All DTC Reading" with CONSULT.
2. Check if the DTC is detected in self-diagnosis results of "ENGINE". Refer to [EC4-145. "DTC Index"](#).

Is any DTC detected?

- YES >> GO TO 2.
NO >> INSPECTION END

2.REPAIR OR REPLACE MALFUNCTIONING PARTS

Repair or replace malfunctioning parts identified by the self-diagnosis result.

>> GO TO 3.

3.CHECK ASCD SYSTEM

1. Erase the self-diagnosis results, and then perform "All DTC Reading" again after performing the action test. (Refer to [CCS-250. "Description"](#) for action test.)
2. Check that the ASCD system is normal.

>> INSPECTION END

A
B
C
D
E
F
G
H
I
J
K
L
M
N
P

CCS

NORMAL OPERATING CONDITION

< SYMPTOM DIAGNOSIS >

[ASCD]

NORMAL OPERATING CONDITION

Description

INFOID:000000013711917

PRECAUTIONS FOR AUTOMATIC SPEED CONTROL DEVICE (ASCD)

- Always observe the posted speed limits and do not set the speed over them.
- Do not use the cruise control when driving under the following conditions. Doing so could cause a loss of vehicle control and result in an accident.
 - When it is not possible to keep the vehicle at a constant speed
 - When driving in heavy traffic
 - When driving in traffic that varies speed
 - When driving in windy areas
 - When driving on winding or hilly roads
 - When driving on slippery (rain, snow, ice, etc.) roads

STEERING SWITCH

< REMOVAL AND INSTALLATION >

[ASCD]

REMOVAL AND INSTALLATION

STEERING SWITCH

Exploded View

INFOID:0000000013711918

ASCD steering switch is integrated in the steering switch.

Refer to [ST-32, "Exploded View"](#).

NOTE:

Always remove ASCD steering switch together with steering wheel.

A
B
C
D
E
F
G
H
I
J
K
L
M
N
P

