

# MICROPHONE SIGNAL CIRCUIT

< DTC/CIRCUIT DIAGNOSIS >

[INFINITI INTOUCH]

## MICROPHONE SIGNAL CIRCUIT WITHOUT TELEMATICS SYSTEM

### WITHOUT TELEMATICS SYSTEM : Description

INFOID:000000013717413

Supply power from display control unit to microphone. The microphone transmits the sound/voice to the display control unit.

### WITHOUT TELEMATICS SYSTEM : Diagnosis Procedure

INFOID:000000013717414

#### 1. CHECK MICROPHONE SIGNAL

1. Turn ignition switch ON.
2. Check the signal between display control unit harness connector terminal as per the following condition.

Display control unit			Condition	Reference value
Connector	Terminals			
	(+)	(-)		
Terminal				
M101	71	52	Give a voice.	

Is the inspection result normal?

- YES >> Replace display control unit. Refer to [AV-431, "Removal and Installation"](#).  
 NO >> GO TO 2.

#### 2. CHECK VOLTAGE MICROPHONE VCC

1. Turn ignition switch OFF.
2. Disconnect microphone harness connector.
3. Turn ignition switch ON.
4. Check the voltage between microphone harness connector.

Microphone			Voltage (Approx.)
Connector	Terminals		
	(+)	(-)	
Terminal			
R12	4	2	5.0 V

Is the inspection result normal?

- YES >> Replace microphone. Refer to [AV-454, "Removal and Installation"](#).  
 NO >> GO TO 3.

#### 3. CHECK MICROPHONE CIRCUIT FOR OPEN

1. Disconnect display control unit harness connector.
2. Check continuity between display control unit harness connector and microphone harness connector.

# MICROPHONE SIGNAL CIRCUIT

< DTC/CIRCUIT DIAGNOSIS >

[INFINITI INTOUCH]

Display control unit		Microphone		Continuity
Connector	Terminals	Connector	Terminals	
M101	52	R12	2	Existed
	71		1	
	72		4	

Is the inspection result normal?

YES >> GO TO 4.

NO >> Repair or replace malfunctioning parts.

## 4.CHECK MICROPHONE CIRCUIT FOR SHORT

Check the continuity between display control unit harness connector and ground.

Terminals		Continuity	
(+)	(-)		
Display control unit		Ground	Not existed
Connector	Terminals		
M101	71	Ground	Not existed
	72		

Is the inspection result normal?

YES >> Replace display control unit. Refer to [AV-431. "Removal and Installation"](#).

NO >> Repair or replace malfunctioning parts.

## WITH TELEMATICS SYSTEM

### WITH TELEMATICS SYSTEM : Description

INFOID:000000013717415

- TCU supplies power to the microphone when receiving a microphone ON signal from the display control unit.
- The microphone transmits an audio signal to TCU.
- TCU transmits a received sound signal to the display control unit.

### WITH TELEMATICS SYSTEM : Diagnosis Procedure

INFOID:000000013717416

## 1.CHECK CONTINUITY BETWEEN DISPLAY CONTROL UNIT AND TCU CIRCUIT

1. Turn ignition switch OFF.
2. Disconnect display control unit harness connector and TCU harness connector.
3. Check the continuity between display control unit harness connector and TCU harness connector.

Display control unit		TCU		Continuity
Connector	Terminals	Connector	Terminals	
M101	71	M144	12	Existed
	52		11	

4. Check the continuity between display control unit harness connector and ground.

Display control unit		Ground	Continuity
Connector	Terminals		Continuity
M101	71	Not existed	

Is the inspection result normal?

YES >> GO TO 2.

NO >> Repair or replace malfunctioning parts.

## 2.CHECK MICROPHONE SIGNAL (DISPLAY CONTROL UNIT TO TCU)

# MICROPHONE SIGNAL CIRCUIT

[INFINITI INTOUCH]

## < DTC/CIRCUIT DIAGNOSIS >

1. Connect TCU harness connector.
2. Turn ignition switch ON.
3. Check the signal between display control unit harness connector.

Display control unit			Condition	Reference value
Connector	Terminals			
	(+)	(-)		
Terminal				
M101	71	52	Give a voice.	

### Is the inspection result normal?

- YES >> Replace display control unit. Refer to [AV-431, "Removal and Installation"](#).  
 NO >> GO TO 3.

## 3. CHECK CONTINUITY BETWEEN TCU AND MICROPHONE CIRCUIT

1. Turn ignition switch OFF.
2. Disconnect TCU harness connector and microphone harness connector.
3. Check the continuity between TCU harness connector and microphone harness connector.

TCU		Microphone		Continuity
Connector	Terminals	Connector	Terminals	
M144	16	R12	2	Existed
	17		1	
	18		4	

4. Check the continuity between TCU harness connector and ground.

TCU		Ground	Continuity
Connector	Terminals		
M144	17		Not existed
	18		

### Is the inspection result normal?

- YES >> GO TO 4.  
 NO >> Repair or replace malfunctioning parts.

## 4. CHECK VOLTAGE MICROPHONE POWER SUPPLY

1. Connect TCU harness connector.
2. Turn ignition switch ON.
3. Check the voltage between TCU harness connector ground.

Terminals			Voltage (Approx.)
(+) TCU		(-)	
Connector	Terminal		
M144	18	Ground	5.0 V

### Is the inspection result normal?

- YES >> GO TO 5.

A  
B  
C  
D  
E  
F  
G  
H  
I  
J  
K  
L  
M

AV

O  
P

# MICROPHONE SIGNAL CIRCUIT

[INFINITI INTOUCH]

< DTC/CIRCUIT DIAGNOSIS >

NO >> Replace TCU. Refer to [AV-799, "Removal and Installation"](#).

## 5. CHECK MICROPHONE SIGNAL (TCU TO MICROPHONE)

1. Turn ignition switch OFF.
2. Connect microphone harness connector.
3. Turn ignition switch ON.
4. Check the signal between TCU harness connector.

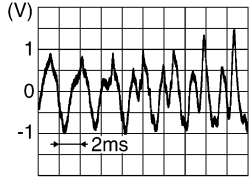
TCU			Condition	Reference value
Connector	Terminals			
	(+)	(-)		
Terminal				
M144	17	16	When inputting interior sound.	 <p>(V)</p> <p>1</p> <p>0</p> <p>-1</p> <p>← 2ms</p> <p>SKIB3609E</p>

Is the inspection result normal?

YES >> Replace TCU. Refer to [AV-799, "Removal and Installation"](#).

NO >> Replace microphone. Refer to [AV-454, "Removal and Installation"](#).

## SOUND SIGNAL CIRCUIT WITHOUT BOSE SYSTEM

### WITHOUT BOSE SYSTEM : Diagnosis Procedure

INFOID:000000013717417

#### 1. CHECK SOUND SIGNAL

1. Turn ignition switch ON.
2. Check the signal between AV control unit terminal as per the following condition.

Sound signal LH

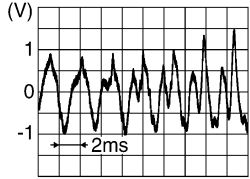
AV control unit			Condition	Reference value
Connector	Terminals			
	(+)	(-)		
Terminal				
M165	61	67	[Ignition switch ON] • Sound output	 <p style="text-align: right; font-size: small;">SKIB3609E</p>

Sound signal RH

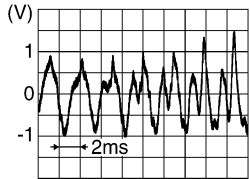
AV control unit			Condition	Reference value
Connector	Terminals			
	(+)	(-)		
Terminal				
M165	62	68	[Ignition switch ON] • Sound output	 <p style="text-align: right; font-size: small;">SKIB3609E</p>

**Is the inspection result normal?**

YES >> Replace AV control unit. Refer to [AV-432, "Removal and Installation"](#).

NO >> GO TO 2.

#### 2. CHECK SOUND SIGNAL CIRCUIT FOR OPEN

1. Turn ignition switch OFF.
2. Disconnect display control unit harness connector and AV control unit harness connector.
3. Check the continuity between display control unit harness connector and AV control unit harness connector.

Sound signal LH

Display control unit		AV control unit		Continuity
Connector	Terminal	Connector	Terminal	
M101	64	M165	61	Existed
	44		67	

A  
B  
C  
D  
E  
F  
G  
H  
I  
J  
K  
L  
M  
O  
P

AV

# SOUND SIGNAL CIRCUIT

[INFINITI INTOUCH]

## < DTC/CIRCUIT DIAGNOSIS >

Sound signal RH

Display control unit		AV control unit		Continuity
Connector	Terminal	Connector	Terminal	
M101	62	M165	62	Existed
	42		68	

Is the inspection result normal?

YES >> GO TO 3.

NO >> Repair or replace malfunctioning parts.

### 3. CHECK SOUND SIGNAL CIRCUIT FOR SHORT

Check the continuity between AV control unit harness connector and ground.

Sound signal LH

Terminals			Continuity
(+)		(-)	
AV control unit			
Connector	Terminal		
M165	61	Ground	Not existed
	67		

Sound signal RH

Terminals			Continuity
(+)		(-)	
AV control unit			
Connector	Terminal		
M165	62	Ground	Not existed
	68		

Is the inspection result normal?

YES >> Replace display control unit. Refer to [AV-431, "Removal and Installation"](#).

NO >> Repair or replace malfunctioning parts.

### WITH BOSE SYSTEM

### WITH BOSE SYSTEM : Diagnosis Procedure

INFOID:0000000013717418

### 1. CHECK SOUND SIGNAL (1)

1. Turn ignition switch ON.
2. Check the signal between AV control unit terminal as per the following condition.

Sound signal LH

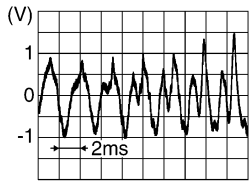
Connector	AV control unit		Condition	Reference value
	Terminals			
	(+)	(-)		
Terminal				
M165	61	67	[Ignition switch ON] • Sound output	 <p style="text-align: right; font-size: small;">SKIB3609E</p>

# SOUND SIGNAL CIRCUIT

< DTC/CIRCUIT DIAGNOSIS >

[INFINITI INTOUCH]

Sound signal RH

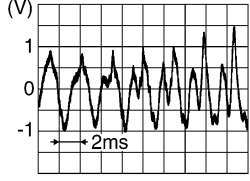
AV control unit			Condition	Reference value
Connector	Terminals			
	(+)	(-)		
Terminal				
M165	62	68	[Ignition switch ON] • Sound output	 <p style="text-align: right; font-size: small;">SKIB3609E</p>

Is the inspection result normal?

- YES >> GO TO 2.
- NO >> GO TO 3.

## 2. CHECK SOUND SIGNAL (2)

Check the signal between BOSE amp. terminal as per the following condition.

Sound signal LH

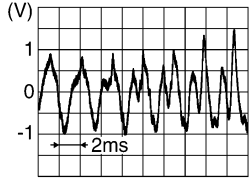
BOSE amp.			Condition	Reference value
Connector	Terminals			
	(+)	(-)		
Terminal				
B55	65	45	[Ignition switch ON] • Sound output	 <p style="text-align: right; font-size: small;">SKIB3609E</p>

Sound signal RH

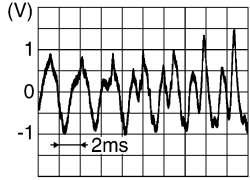
BOSE amp.			Condition	Reference value
Connector	Terminals			
	(+)	(-)		
Terminal				
B55	66	46	[Ignition switch ON] • Sound output	 <p style="text-align: right; font-size: small;">SKIB3609E</p>

Is the inspection result normal?

- YES >> Replace BOSE amp. Refer to [AV-438. "Removal and Installation"](#).
- NO >> GO TO 5.

## 3. CHECK SOUND SIGNAL CIRCUIT FOR OPEN

1. Turn ignition switch OFF.
2. Disconnect display control unit harness connector and AV control unit harness connector.
3. Check the continuity between display control unit harness connector and AV control unit harness connector.

A  
B  
C  
D  
E  
F  
G  
H  
I  
J  
K  
L  
M  
O  
P

AV

# SOUND SIGNAL CIRCUIT

[INFINITI INTOUCH]

## < DTC/CIRCUIT DIAGNOSIS >

Sound signal LH

Display control unit		AV control unit		Continuity
Connector	Terminal	Connector	Terminal	
M101	64	M165	61	Existed
	44		67	

Sound signal RH

Display control unit		AV control unit		Continuity
Connector	Terminal	Connector	Terminal	
M101	62	M165	62	Existed
	42		68	

Is the inspection result normal?

YES >> GO TO 4.

NO >> Repair or replace malfunctioning parts.

### 4. CHECK SOUND SIGNAL CIRCUIT FOR SHORT

Check the continuity between AV control unit harness connector and ground.

Sound signal LH

Terminals			Continuity
(+)		(-)	
AV control unit			
Connector	Terminal	Ground	Not existed
M165	61		
		67	

Sound signal RH

Terminals			Continuity
(+)		(-)	
AV control unit			
Connector	Terminal	Ground	Not existed
M165	62		
		68	

Is the inspection result normal?

YES >> Replace display control unit. Refer to [AV-431. "Removal and Installation"](#).

NO >> Repair or replace malfunctioning parts.

### 5. CHECK SOUND SIGNAL CIRCUIT FOR OPEN

1. Turn ignition switch OFF.
2. Disconnect AV control unit harness connector and BOSE amp. harness connector.
3. Check the continuity between AV control unit harness connector and BOSE amp. harness connector.

Sound signal LH

AV control unit		BOSE amp.		Continuity
Connector	Terminal	Connector	Terminal	
M163	2	B55	65	Existed
	3		45	

# SOUND SIGNAL CIRCUIT

< DTC/CIRCUIT DIAGNOSIS >

[INFINITI INTOUCH]

Sound signal RH

AV control unit		BOSE amp.		Continuity
Connector	Terminal	Connector	Terminal	
M163	11	B55	66	Existed
	12		46	

Is the inspection result normal?

YES >> GO TO 6.

NO >> Repair or replace malfunctioning parts.

## 6. CHECK SOUND SIGNAL CIRCUIT FOR SHORT

Check the continuity between AV control unit harness connector and ground.

Sound signal LH

Terminals			Continuity
(+)		(-)	
BOSE amp.			
Connector	Terminal		
B55	65	Ground	Not existed
	45		

Sound signal RH

Terminals			Continuity
(+)		(-)	
BOSE amp.			
Connector	Terminal		
B55	66	Ground	Not existed
	46		

Is the inspection result normal?

YES >> Replace AV control unit. Refer to [AV-432, "Removal and Installation"](#).

NO >> Repair or replace malfunctioning parts.

A  
B  
C  
D  
E  
F  
G  
H  
I  
J  
K  
L  
M

AV

O  
P

# STEERING SWITCH SIGNAL A CIRCUIT

< DTC/CIRCUIT DIAGNOSIS >

[INFINITI INTOUCH]

## STEERING SWITCH SIGNAL A CIRCUIT

### Component Function Check

INFOID:000000013717419

#### 1.PERFORM COMPONENT FUNCTION CHECK (1)

1. Turn ignition switch ON.
2. Perform On Board Diagnosis Function, and then check steering switch input signal. Refer to [AV-89, "On Board Diagnosis Function"](#).

Is the inspection result normal?

- YES >> INSPECTION END  
NO >> GO TO 2.

#### 2.PERFORM COMPONENT FUNCTION CHECK (2)

Ⓜ With CONSULT

Check "Self Diagnostic Result" of "MULTI AV".

Is DTC U1300 detected?

- YES >> Refer to [AV-361, "DTC Description"](#).  
NO >> Refer to [AV-412, "Diagnosis Procedure"](#).

### Diagnosis Procedure

INFOID:000000013717420

#### 1.CHECK STEERING SWITCH SIGNAL A CIRCUIT

1. Turn ignition switch OFF.
2. Disconnect combination meter harness connector and spiral cable harness connector.
3. Check the continuity between combination meter harness connector and spiral cable harness connector.

Without ICC

Combination meter		Spiral cable		Continuity
Connector	Terminal	Connector	Terminal	
M57	22	M87	24	Existed

With ICC

Combination meter		Spiral cable		Continuity
Connector	Terminal	Connector	Terminal	
M57	22	M190	34	Existed

4. Check the continuity between combination meter harness connector and ground.

Combination meter		Ground	Continuity
Connector	Terminal		
M57	22		Not existed

Is the inspection result normal?

- YES >> GO TO 2.  
NO >> Repair or replace malfunctioning parts.

#### 2.CHECK STEERING SWITCH GROUND CIRCUIT

1. Disconnect combination meter harness connector and spiral cable harness connector.
2. Check the continuity between combination meter harness connector and spiral cable harness connector.

Without ICC

Combination meter		Spiral cable		Continuity
Connector	Terminal	Connector	Terminal	
M57	21	M87	33	Existed

# STEERING SWITCH SIGNAL A CIRCUIT

< DTC/CIRCUIT DIAGNOSIS >

[INFINITI INTOUCH]

With ICC

Combination meter		Spiral cable		Continuity
Connector	Terminal	Connector	Terminal	
M57	21	M190	32	Existed

3. Check the continuity between combination meter harness connector and ground.

Combination meter		Ground	Continuity
Connector	Terminal		
M57	21		Not existed

Is the inspection result normal?

YES >> GO TO 3.

NO >> Repair or replace malfunctioning parts.

## 3.CHECK SPIRAL CABLE

1. Disconnect steering switch connector.
2. Check the continuity between spiral cable harness connectors.

Without ICC

Spiral cable				Continuity
Connector	Terminal	Connector	Terminal	
M87	24	M301	14	Existed

With ICC

Spiral cable				Continuity
Connector	Terminal	Connector	Terminal	
M190	34	M302	13	Existed

Is the inspection result normal?

YES >> GO TO 4.

NO >> Replace spiral cable. Refer to [SR-21. "Removal and Installation"](#).

## 4.CHECK STEERING SWITCH

Check steering switch. Refer to [AV-413. "Component Inspection"](#).

Is the inspection result normal?

YES >> INSPECTION END

NO >> Replace steering wheel. Refer to following.

- Models with vehicle speed sensitive P/S: [ST-32. "Removal and Installation"](#).
- Models with direct adaptive steering: [ST-133. "Removal and Installation"](#).

## Component Inspection

INFOID:000000013717421

WITHOUT ICC

## 1.CHECK STEERING SWITCH

1. Disconnect steering switch harness connector.
2. Check the resistance between the steering switch connector terminals.

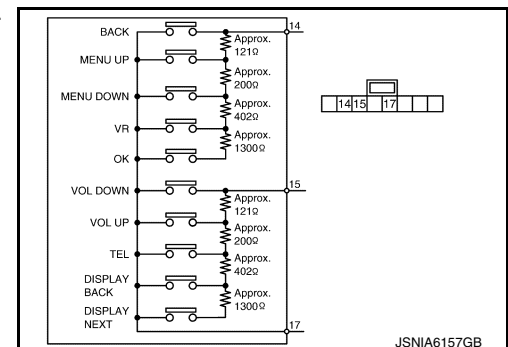

JSNIA6157GB

# STEERING SWITCH SIGNAL A CIRCUIT

< DTC/CIRCUIT DIAGNOSIS >

[INFINITI INTOUCH]

Steering switch		Condition	Resistance (Approx.) $\Omega$
Terminal			
14	17	BACK switch ON	1
		MENU UP switch ON	119 – 123
		MENU DOWN switch ON	315 – 327
		Voice recognition switch ON	709 – 737
		MENU OK switch ON	1983 – 2063
15	17	VOL DOWN switch ON	1
		VOL UP switch ON	119 – 123
		TEL switch ON	315 – 327
		DISPLAY BACK switch ON	709 – 737
		DISPLAY NEXT switch ON	1983 – 2063

Is the inspection result normal?

YES >> INSPECTION END

NO >> Replace steering wheel. Refer to following.

- Models with vehicle speed sensitive P/S: [ST-32, "Removal and Installation"](#).
- Models with direct adaptive steering: [ST-133, "Removal and Installation"](#).

WITH ICC

## 1. CHECK STEERING SWITCH

1. Disconnect steering switch harness connector.
2. Check the resistance between the steering switch connector terminals.

Steering switch		Condition	Resistance (Approx.) $\Omega$
Terminal			
13	15	BACK switch ON	1
		MENU UP switch ON	119 – 123
		MENU DOWN switch ON	315 – 327
		Voice recognition switch ON	709 – 737
		MENU OK switch ON	1983 – 2063
14	15	VOL DOWN switch ON	1
		VOL UP switch ON	119 – 123
		TEL switch ON	315 – 327
		DISPLAY BACK switch ON	709 – 737
		DISPLAY NEXT switch ON	1983 – 2063

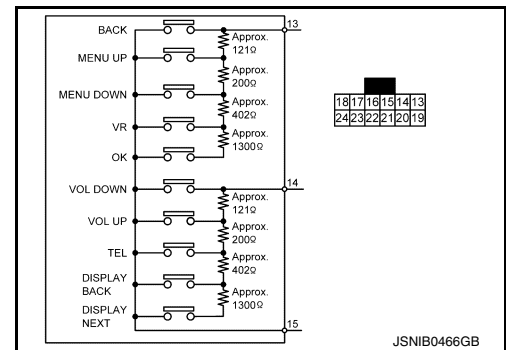

Is the inspection result normal?

YES >> INSPECTION END

NO >> Replace steering wheel. Refer to following.

- Models with vehicle speed sensitive P/S: [ST-32, "Removal and Installation"](#).
- Models with direct adaptive steering: [ST-133, "Removal and Installation"](#).

# STEERING SWITCH SIGNAL B CIRCUIT

< DTC/CIRCUIT DIAGNOSIS >

[INFINITI INTOUCH]

## STEERING SWITCH SIGNAL B CIRCUIT

### Component Function Check

INFOID:000000013717422

#### 1.PERFORM COMPONENT FUNCTION CHECK (1)

1. Turn ignition switch ON.
2. Perform On Board Diagnosis Function, and then check steering switch input signal. Refer to [AV-89, "On Board Diagnosis Function"](#).

Is the inspection result normal?

- YES >> INSPECTION END  
NO >> GO TO 2.

#### 2.PERFORM COMPONENT FUNCTION CHECK (2)

ⓂWith CONSULT

Check "Self Diagnostic Result" of "MULTI AV".

Is DTC U1300 detected?

- YES >> Refer to [AV-361, "DTC Description"](#).  
NO >> Refer to [AV-415, "Diagnosis Procedure"](#).

### Diagnosis Procedure

INFOID:000000013717423

#### 1.CHECK STEERING SWITCH SIGNAL B CIRCUIT

1. Turn ignition switch OFF.
2. Disconnect combination meter harness connector and spiral cable harness connector.
3. Check continuity between combination meter harness connector and spiral cable harness connector.

Without ICC

Combination meter		Spiral cable		Continuity
Connector	Terminal	Connector	Terminal	
M57	23	M87	31	Existed

With ICC

Combination meter		Spiral cable		Continuity
Connector	Terminal	Connector	Terminal	
M57	23	M190	33	Existed

4. Check continuity between combination meter harness connector and ground.

Combination meter		Ground	Continuity
Connector	Terminal		
M57	23		Not existed

Is the inspection result normal?

- YES >> GO TO 2.  
NO >> Repair harness or connector.

#### 2.CHECK STEERING SWITCH GROUND CIRCUIT

1. Disconnect combination meter harness connector and spiral cable harness connector.
2. Check continuity between combination meter harness connector and spiral cable harness connector.

Without ICC

Combination meter		Spiral cable		Continuity
Connector	Terminal	Connector	Terminal	
M57	21	M87	33	Existed

A  
B  
C  
D  
E  
F  
G  
H  
I  
J  
K  
L  
M  
O  
P

AV

# STEERING SWITCH SIGNAL B CIRCUIT

[INFINITI INTOUCH]

## < DTC/CIRCUIT DIAGNOSIS >

With ICC

Combination meter		Spiral cable		Continuity
Connector	Terminal	Connector	Terminal	
M57	21	M190	32	Existed

3. Check continuity between combination meter harness connector and ground.

Combination meter		Ground	Continuity
Connector	Terminal		
M57	21		Not existed

Is the inspection result normal?

YES >> GO TO 3.

NO >> Repair harness or connector.

### 3.CHECK SPIRAL CABLE

1. Disconnect steering switch connector.
2. Check continuity between spiral cable harness connectors.

Without ICC

Spiral cable				Continuity
Connector	Terminal	Connector	Terminal	
M87	31	M301	15	Existed

With ICC

Spiral cable				Continuity
Connector	Terminal	Connector	Terminal	
M190	33	M302	14	Existed

Is the inspection result normal?

YES >> GO TO 4.

NO >> Replace spiral cable. Refer to [SR-21, "Removal and Installation"](#).

### 4.CHECK STEERING SWITCH

Check steering switch. Refer to [AV-416, "Component Inspection"](#).

Is the inspection result normal?

YES >> INSPECTION END

NO >> Replace steering wheel. Refer to following.

- Models with vehicle speed sensitive P/S: [ST-32, "Removal and Installation"](#).
- Models with direct adaptive steering: [ST-133, "Removal and Installation"](#).

### Component Inspection

INFOID:000000013717424

WITHOUT ICC

### 1.CHECK STEERING SWITCH

1. Disconnect steering switch harness connector.
2. Check the resistance between the steering switch connector terminals.

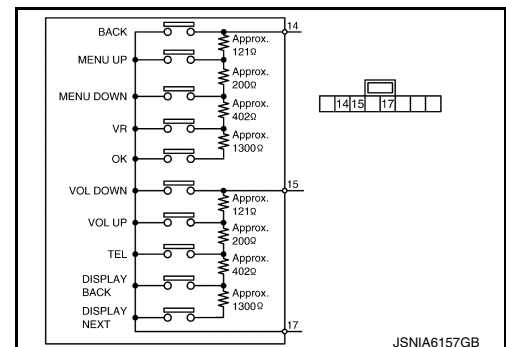

JSNIA6157GB

# STEERING SWITCH SIGNAL B CIRCUIT

< DTC/CIRCUIT DIAGNOSIS >

[INFINITI INTOUCH]

Steering switch		Condition	Resistance (Approx.) $\Omega$
Terminal			
14	17	BACK switch ON	1
		MENU UP switch ON	119 – 123
		MENU DOWN switch ON	315 – 327
		Voice recognition switch ON	709 – 737
		MENU OK switch ON	1983 – 2063
15	17	VOL DOWN switch ON	1
		VOL UP switch ON	119 – 123
		TEL switch ON	315 – 327
		DISPLAY BACK switch ON	709 – 737
		DISPLAY NEXT switch ON	1983 – 2063

Is the inspection result normal?

YES >> INSPECTION END

NO >> Replace steering wheel. Refer to following.

- Models with vehicle speed sensitive P/S: [ST-32, "Removal and Installation"](#).
- Models with direct adaptive steering: [ST-133, "Removal and Installation"](#).

WITH ICC

## 1. CHECK STEERING SWITCH

1. Disconnect steering switch harness connector.
2. Check the resistance between the steering switch connector terminals.

Steering switch		Condition	Resistance (Approx.) $\Omega$
Terminal			
13	15	BACK switch ON	1
		MENU UP switch ON	119 – 123
		MENU DOWN switch ON	315 – 327
		Voice recognition switch ON	709 – 737
		MENU OK switch ON	1983 – 2063
14	15	VOL DOWN switch ON	1
		VOL UP switch ON	119 – 123
		TEL switch ON	315 – 327
		DISPLAY BACK switch ON	709 – 737
		DISPLAY NEXT switch ON	1983 – 2063

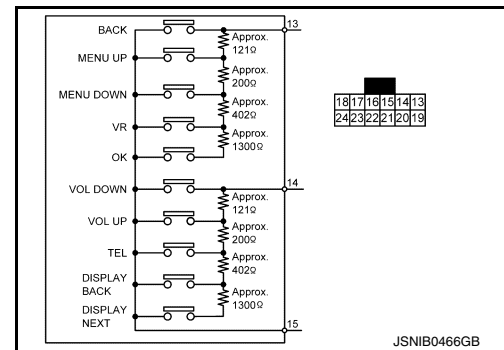

Is the inspection result normal?

YES >> INSPECTION END

NO >> Replace steering wheel. Refer to following.

- Models with vehicle speed sensitive P/S: [ST-32, "Removal and Installation"](#).
- Models with direct adaptive steering: [ST-133, "Removal and Installation"](#).

# VOICE GUIDANCE SIGNAL CIRCUIT

< DTC/CIRCUIT DIAGNOSIS >

[INFINITI INTOUCH]

## VOICE GUIDANCE SIGNAL CIRCUIT

### BASE AUDIO WITHOUT NAVIGATION

### BASE AUDIO WITHOUT NAVIGATION : Diagnosis Procedure

INFOID:000000013717425

#### 1. CHECK VOICE GUIDANCE SIGNAL OUTPUT

1. Turn ignition switch ON.
2. Check the signal between AV control unit terminals as per the following condition.

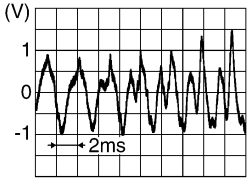
AV control unit			Condition	Continuity
Connector	Terminals			
	(+)	(-)		
Terminal				
M166	75	83	Sound output	

Is the inspection result normal?

- YES >> Replace AV control unit. Refer to [AV-432. "Removal and Installation"](#).  
 NO >> GO TO 2.

#### 2. CHECK VOICE GUIDANCE OUTPUT SIGNAL CIRCUIT FOR OPEN

1. Turn ignition switch OFF.
2. Disconnect AV control unit harness connector and display control unit harness connector.
3. Check the continuity between AV control unit harness connector and display control unit harness connector.

AV control unit		Display control unit		Continuity
Connector	Terminal	Connector	Terminal	
M166	75	M101	67	Existed
	83		47	

Is the inspection result normal?

- YES >> GO TO 3.  
 NO >> Repair or replace malfunctioning parts.

#### 3. CHECK VOICE GUIDANCE OUTPUT SIGNAL FOR SHORT

Check the continuity between AV control unit harness connector and ground.

Terminals			Continuity
(+)		(-)	
AV control unit			
Connector	Terminal	Ground	
M166	75		Ground
	83		

Is the inspection result normal?

- YES >> Replace display control unit. Refer to [AV-431. "Removal and Installation"](#).  
 NO >> Repair or replace malfunctioning parts.

### BOSE AUDIO WITHOUT NAVIGATION

# VOICE GUIDANCE SIGNAL CIRCUIT

< DTC/CIRCUIT DIAGNOSIS >

[INFINITI INTOUCH]

## BOSE AUDIO WITHOUT NAVIGATION : Diagnosis Procedure

INFOID:000000014248431

### 1.CHECK VOICE GUIDANCE SIGNAL OUTPUT

1. Turn ignition switch ON.
2. Check the signal between BOSE amp. terminals as per the following condition.

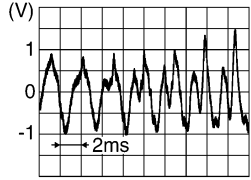
BOSE amp.			Condition	Continuity
Connector	Terminals			
	(+)	(-)		
Terminal				
B55	64	44	Sound output	

Is the inspection result normal?

- YES >> Replace BOSE amp. Refer to [AV-438, "Removal and Installation"](#).  
 NO >> GO TO 2.

### 2.CHECK VOICE GUIDANCE OUTPUT SIGNAL CIRCUIT FOR OPEN

1. Turn ignition switch OFF.
2. Disconnect BOSE amp. harness connector and display control unit harness connector.
3. Check the continuity between BOSE amp. harness connector and display control unit harness connector.

BOSE amp.		Display control unit		Continuity
Connector	Terminal	Connector	Terminal	
B55	64	M101	67	Existed
	44		47	

Is the inspection result normal?

- YES >> GO TO 3.  
 NO >> Repair or replace malfunctioning parts.

### 3.CHECK VOICE GUIDANCE OUTPUT SIGNAL FOR SHORT

Check the continuity between BOSE amp. harness connector and ground.

Terminals			Continuity
(+) BOSE amp.		(-)	
Connector	Terminal		
B55	64	Ground	Not existed
	44		

Is the inspection result normal?

- YES >> Replace display control unit. Refer to [AV-431, "Removal and Installation"](#).  
 NO >> Repair or replace malfunctioning parts.

## BOSE AUDIO WITH NAVIGATION

### BOSE AUDIO WITH NAVIGATION : Diagnosis Procedure

INFOID:000000013717426

### 1.CHECK VOICE GUIDANCE SIGNAL INPUT

# VOICE GUIDANCE SIGNAL CIRCUIT

[INFINITI INTOUCH]

## < DTC/CIRCUIT DIAGNOSIS >

1. Turn ignition switch ON.
2. Check the signal between display control unit terminals as per the following condition.

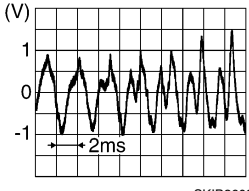
Display control unit			Condition	Continuity
Connector	Terminals			
	(+)	(-)		
Terminal				
M101	68	48	Sound output	

Is the inspection result normal?

- YES >> GO TO 2.  
 NO >> GO TO 3.

## 2. CHECK VOICE GUIDANCE SIGNAL OUTPUT

Check the signal between BOSE amp. terminals as per the following condition.

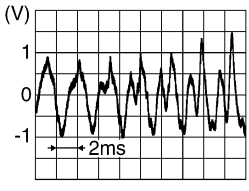
BOSE amp.			Condition	Continuity
Connector	Terminals			
	(+)	(-)		
Terminal				
B55	64	44	Sound output	

Is the inspection result normal?

- YES >> Replace BOSE amp. Refer to [AV-438, "Removal and Installation"](#).  
 NO >> GO TO 5.

## 3. CHECK VOICE GUIDANCE INPUT SIGNAL CIRCUIT FOR OPEN

1. Turn ignition switch OFF.
2. Disconnect display control unit harness connector and NAVI control unit harness connector.
3. Check the continuity between display control unit harness connector and NAVI control unit harness connector.

Display control unit		NAVI control unit		Continuity
Connector	Terminal	Connector	Terminal	
M101	68	M60	14	Existed
	48		28	

Is the inspection result normal?

- YES >> GO TO 4.  
 NO >> Repair or replace malfunctioning parts.

## 4. CHECK VOICE GUIDANCE INPUT SIGNAL FOR SHORT

Check the continuity between display control unit harness connector and ground.

# VOICE GUIDANCE SIGNAL CIRCUIT

< DTC/CIRCUIT DIAGNOSIS >

[INFINITI INTOUCH]

Terminals			Continuity
(+)		(-)	
Display control unit			
Connector	Terminal		
M101	68	Ground	Not existed
	48		

Is the inspection result normal?

- YES >> Replace NAVI control unit. Refer to [AV-433, "Removal and Installation"](#).  
NO >> Repair or replace malfunctioning parts.

## 5.CHECK VOICE GUIDANCE OUTPUT SIGNAL CIRCUIT FOR OPEN

1. Turn ignition switch OFF.
2. Disconnect BOSE amp. harness connector and display control unit harness connector.
3. Check the continuity between BOSE amp. harness connector and display control unit harness connector.

BOSE amp.		Display control unit		Continuity
Connector	Terminal	Connector	Terminal	
B55	64	M101	67	Existed
	44		47	

Is the inspection result normal?

- YES >> GO TO 6.  
NO >> Repair or replace malfunctioning parts.

## 6.CHECK VOICE GUIDANCE OUTPUT SIGNAL FOR SHORT

Check the continuity between BOSE amp. harness connector and ground.

Terminals			Continuity
(+)		(-)	
BOSE amp.			
Connector	Terminal		
B55	64	Ground	Not existed
	44		

Is the inspection result normal?

- YES >> Replace display control unit. Refer to [AV-431, "Removal and Installation"](#).  
NO >> Repair or replace malfunctioning parts.

A  
B  
C  
D  
E  
F  
G  
H  
I  
J  
K  
L  
M  
O  
P

AV

## SYMPTOM DIAGNOSIS

### MULTI AV SYSTEM SYMPTOMS

#### Symptom Table

INFOID:000000013717427

#### RELATED TO NAVIGATION

Symptoms	Check items	Probable malfunction location
MAP is not displayed	The navigation system-related operation can be operated.	LVDS signal circuit between display control unit and integral switch malfunction.
	The navigation system-related operation cannot be operated.	NAVI control unit power supply and ground circuit malfunction. Refer to <a href="#">AV-392. "NAVI CONTROL UNIT : Diagnosis Procedure"</a> .
	"Map data cannot be read. Please confirm~" is displayed on the screen.	<ul style="list-style-type: none"> <li>Check whether SD card is inserted correctly.</li> <li>USB harness between external data input box and NAVI control unit.</li> </ul>
	Only icons, such as a vehicle mark and a clock, are displayed on the screen of display control unit by the background of the black screen.	LVDS harness between display control unit and NAVI control unit.
Fuel economy display, vehicle setting operation is abnormal.	There is malfunction in the CONSULT "self-diagnosis result" of "MULTI AV". Refer to <a href="#">AV-102. "CONSULT Function"</a> .	Perform detected DTC diagnosis. Refer to <a href="#">AV-113. "DTC Index"</a> .
	There is no malfunction in the CONSULT "self-diagnosis results" of "MULTI AV". Refer to <a href="#">AV-102. "CONSULT Function"</a> .	Ignition signal circuit malfunction. Refer to <a href="#">AV-390. "DISPLAY CONTROL UNIT : Diagnosis Procedure"</a> .
Guide sound is not heard or too low.	On the setting display select "system sound (guide sound volume, etc.)," and confirm that guide sound is ON.	Voice guidance signal circuit malfunction. Refer to <a href="#">AV-418. "BASE AUDIO WITHOUT NAVIGATION : Diagnosis Procedure"</a> . (Without BOSE system.) Refer to <a href="#">AV-419. "BOSE AUDIO WITH NAVIGATION : Diagnosis Procedure"</a> . (With BOSE system.)

#### RELATED TO HANDS-FREE PHONE

- Before performing diagnosis, confirm that the cellular phone being used by the customer is compatible with the vehicle.
- It is possible that a malfunction is occurring due to a version change of the phone even though the phone is a compatible type. This can be confirmed by changing the cellular phone to another compatible type, and checking that it operates normally. It is important to determine whether the cause of the malfunction is the vehicle or the cellular phone.

#### Check Compatibility

1. Make sure the customer's Bluetooth<sup>®</sup> related concern is understood.
2. Verify the customer's concern.
 

**NOTE:**  
The customer's phone may be required, depending upon their concern.
3. Write down the customer's phone brand, model, and service provider.
 

**NOTE:**  
It is necessary to know the service provider. On occasion, a given phone may be on the approved list with one provider, but may not be on the approved list with other providers.
4. Go to "www.nissanusa.com/bluetooth/".
  - a. Using the website's search engine, find out if the customer's phone is on the approved list.
  - b. If the customer's phone is NOT on the approved list:
 

Stop diagnosis here. The customer needs to obtain a Bluetooth<sup>®</sup> phone that is on the approved list before any further action.
  - c. If the feature related to the customer's concern shows as "N" (not compatible):

# MULTI AV SYSTEM SYMPTOMS

[INFINITI INTOUCH]

## < SYMPTOM DIAGNOSIS >

Stop diagnosis here. If the customer still wants the feature to function, they will need to get an approved phone showing the feature as “Y” (compatible) in the “Basic Features” list.

- d. If the feature related to the customer's concern shows as “Y” (compatible):  
Perform diagnosis as per the following table.

Symptoms	Check items	Probable malfunction location
Does not recognize cellular phone connection. (no connection is displayed on the display at the guide.)	Repeat the registration of cellular phone.	
Hands-free phone cannot be established.	<ul style="list-style-type: none"> <li>Hands-free phone operation can be made, but the communication cannot be established.</li> <li>Hands-free phone operation can be performed, however, voice between each other cannot be heard during the conversation.</li> </ul>	Display control unit malfunction. Replace display control unit. Refer to <a href="#">AV-431, "Removal and Installation"</a> .
The other party's voice cannot be heard by hands-free phone.	Check the “Voice Microphone Test” in Confirmation/Adjustment mode if sound is heard.	
Originating sound is not heard by the other party with hands-free phone communication.	Sound operation function is normal.	
	Sound operation function does not work.	Microphone signal circuit malfunction. Refer to <a href="#">AV-403, "WITHOUT TELEMATICS SYSTEM : Diagnosis Procedure"</a> .
The system cannot be operated.	Steering switch's "VOL UP", "VOL DOWN" and "☞" switches works, but "☛" switch does not work.	Steering switch signal A circuit malfunction. Refer to <a href="#">AV-412, "Diagnosis Procedure"</a> .
	<ul style="list-style-type: none"> <li>The voice recognition can be controlled.</li> <li>Steering switch "☛" switch work, but "VOL UP", "VOL DOWN" and "☞" switches do not work.</li> </ul>	Steering switch signal B circuit malfunction. Refer to <a href="#">AV-415, "Diagnosis Procedure"</a> .

## RELATED TO VOICE CONTROL

Symptoms	Check items	Probable malfunction location
The voice cannot be controlled even if the voice control screen is displayed.	Voice sounds at “Voice Microphone Test” of Confirmation/Adjustment mode.	Display control unit malfunction. Replace display control unit. Refer to <a href="#">AV-431, "Removal and Installation"</a> .
	Voice does not sound at “Voice Microphone Test” of Confirmation/Adjustment mode.	Microphone circuit malfunction. Refer to <a href="#">AV-403, "WITHOUT TELEMATICS SYSTEM : Diagnosis Procedure"</a> .
The voice cannot be controlled (Voice control screen is not displayed).	<ul style="list-style-type: none"> <li>Hands-free phone system can be operated.</li> <li>Steering switch's "MENU UP", "MENU DOWN", "☞" and "OK" switches do not work.</li> </ul>	Steering switch signal A circuit malfunction. Refer to <a href="#">AV-412, "Diagnosis Procedure"</a> .

## RELATED TO AUDIO

Symptoms	Check items	Probable malfunction location
The disk cannot be removed.	—	Disk eject signal circuit malfunction. Refer to <a href="#">AV-401, "Diagnosis Procedure"</a> .

# MULTI AV SYSTEM SYMPTOMS

< SYMPTOM DIAGNOSIS >

[INFINITI INTOUCH]

Symptoms	Check items	Probable malfunction location
No sound comes out or the level of the sound is low.	No sound from all speakers.	Without BOSE system <ul style="list-style-type: none"> <li>• Sound signal circuit malfunction. Refer to <a href="#">AV-407, "WITHOUT BOSE SYSTEM : Diagnosis Procedure"</a>.</li> </ul> With BOSE system <ul style="list-style-type: none"> <li>• Sound signal circuit malfunction. Refer to <a href="#">AV-408, "WITH BOSE SYSTEM : Diagnosis Procedure"</a>.</li> <li>• BOSE amp. power supply and ground circuit malfunction. Refer to <a href="#">AV-394, "BOSE AMP. : Diagnosis Procedure"</a>.</li> </ul>
	Sound is not heard from woofer.	Sound signal (woofer) circuit malfunction.
Noise is mixed with audio.	Noise comes out from all speakers.	Without BOSE system <ul style="list-style-type: none"> <li>• Malfunction in display control unit.</li> <li>• Malfunction in AV control unit.</li> </ul> With BOSE system <ul style="list-style-type: none"> <li>• Malfunction in display control unit.</li> <li>• Malfunction in AV control unit.</li> <li>• Malfunction in BOSE amp.</li> </ul>
	Noise comes out only from a certain speaker (front right, front left, rear right, or rear left).	Without BOSE system <ul style="list-style-type: none"> <li>• Poor connector connection of speaker.</li> <li>• Sound signal circuit malfunction. Refer to <a href="#">AV-407, "WITHOUT BOSE SYSTEM : Diagnosis Procedure"</a>.</li> <li>• Malfunction in speaker.</li> <li>• Poor installation of speaker (e.g. backlash and looseness)</li> <li>• Malfunction in display control unit.</li> <li>• Malfunction in AV control unit.</li> </ul> With BOSE system <ul style="list-style-type: none"> <li>• Poor connector connection of speaker.</li> <li>• Sound signal circuit malfunction. Refer to <a href="#">AV-408, "WITH BOSE SYSTEM : Diagnosis Procedure"</a>.</li> <li>• Malfunction in speaker.</li> <li>• Poor installation of speaker (e.g. backlash and looseness)</li> <li>• Malfunction in display control unit.</li> <li>• Malfunction in AV control unit.</li> <li>• Malfunction in BOSE amp.</li> </ul>
	Noise is mixed with radio only (when the car hits a bump or while driving over bad roads).	Poor connector connection of antenna or antenna feeder.
	Radio is not received or poor reception.	<ul style="list-style-type: none"> <li>• Other audio sounds are normal.</li> <li>• Any radio cannot be received or poor reception is caused even after moving to a service area with good reception (e.g. a place with clear view and no obstacles generation external noises).</li> </ul> <ul style="list-style-type: none"> <li>• Antenna amp. ON signal circuit malfunction.</li> <li>• Poor connector connection of antenna or antenna feeder.</li> </ul>

## RELATED TO STEERING SWITCH

Symptoms	Probable malfunction location
None of the steering switch operations work.	Steering switch malfunction. Replace steering wheel. Refer to following.
Only specified switch cannot be operated.	<ul style="list-style-type: none"> <li>• Models with vehicle speed sensitive P/S: <a href="#">ST-32, "Removal and Installation"</a>.</li> <li>• Models with direct adaptive steering: <a href="#">ST-133, "Removal and Installation"</a>.</li> </ul>

# MULTI AV SYSTEM SYMPTOMS

< SYMPTOM DIAGNOSIS >

[INFINITI INTOUCH]

Symptoms	Probable malfunction location
Steering switch's "⤴", "MENU UP", "MENU DOWN", "⤵" and "OK" switches do not work.	Steering switch signal A circuit malfunction. Refer to <a href="#">AV-412, "Diagnosis Procedure"</a> .
Steering switch's "VOL UP", "VOL DOWN" and "⏻" switches do not work.	Steering switch signal B circuit malfunction. Refer to <a href="#">AV-415, "Diagnosis Procedure"</a> .

## RELATED TO INTEGRAL SWITCH

### NOTE:

Check that there is no malfunction of integral switch main body before performing a diagnosis.

Symptoms	Check items	Probable malfunction location
Integral switch and multifunction switch operation does not work.	<ul style="list-style-type: none"> <li>All switches cannot be operated.</li> <li>Integral switch display screen is displayed</li> <li>"MULTI AV" is displayed on system selection screen when the CONSULT is started.</li> </ul>	AV communication circuit between display control unit and integral switch malfunction. Perform CONSULT self-diagnosis. Refer to <a href="#">AV-102, "CONSULT Function"</a> .
	<ul style="list-style-type: none"> <li>All switches cannot be operated.</li> <li>Integral switch display screen is not displayed</li> <li>"MULTI AV" is displayed on system selection screen when the CONSULT is started.</li> </ul>	Integral switch power supply and ground circuit malfunction. Refer to <a href="#">AV-395, "INTEGRAL SWITCH : Diagnosis Procedure"</a> .
	<ul style="list-style-type: none"> <li>All switches cannot be operated.</li> <li>"MULTI AV" is not displayed on system selection screen when the CONSULT is initialized.</li> </ul>	Display control unit power supply and ground circuit malfunction. Refer to <a href="#">AV-390, "DISPLAY CONTROL UNIT : Diagnosis Procedure"</a> .
	Only specified switch cannot be operated.	Integral switch or multifunction switch malfunction. Perform multifunction switch and preset switch self-diagnosis function. Refer to <a href="#">AV-89, "On Board Diagnosis Function"</a> .
Integral switch display screen is not displayed	Switches can be operated.	LVDS signal circuit between display control unit and integral switch.
	Switches cannot be operated.	Integral switch power supply and ground circuit malfunction. Refer to <a href="#">AV-395, "INTEGRAL SWITCH : Diagnosis Procedure"</a> .

## RELATED TO EXTERNAL DATA INPUT BOX

### NOTE:

Check that there is no malfunction of external data input box main body before performing a diagnosis.

Symptoms	Probable malfunction location
No voice sound is heard when AUX mode is selected.	AUX sound signal circuit between external data input box and AV control unit.
Image is not displayed when AUX mode is selected.	<ul style="list-style-type: none"> <li>AUX image signal circuit between external data input box and AV control unit.</li> <li>Composite image signal circuit between AV control unit and display control unit. Refer to <a href="#">AV-399, "Diagnosis Procedure"</a>.</li> </ul>
iPod® or USB memory can not be recognized.	<ul style="list-style-type: none"> <li>USB harness malfunction.</li> <li>USB connector malfunction.</li> </ul>

iPod® is a trademark of Apple inc., registered in the U.S. and other countries.

# NORMAL OPERATING CONDITION

< SYMPTOM DIAGNOSIS >

[INFINITI INTOUCH]

## NORMAL OPERATING CONDITION

### Description

INFOID:000000013717428

**NOTE:**

For Navigation system operation information, refer to Navigation system Owner's Manual.

### BASIC OPERATIONS

Symptom	Possible cause	Possible solution
No image is displayed.	The brightness is at the lowest setting.	Adjust the brightness of the display.
	The systems in the video mode.	Press "DISC-AUX" to change the mode.
	The display is turned off.	Press "☀/☾" to turn on the display.
	The interior of the vehicle becomes the a little less than 80°C (176°F) or high temperature, and the protection of the display acts, and a display is turned OFF.	Wait until the interior of the vehicle has cooled down.
Screen not clear.	Contrast setting is not appropriate.	Adjust the contrast of the display.
No voice guidance is available. Or The volume is too high or too low.	The volume is not set correctly, or it is turned OFF.	Adjust the volume of voice guidance.
	Voice guidance is not provided for certain streets (roads displayed in gray).	This is not a malfunction.
No map is displayed on the screen.	A screen other than map screen is displayed.	Press "MAP" switch.
The screen is too dim. The movement is slow.	The temperature in the interior of the vehicle is low.	Wait until the interior of the vehicle has warmed up.
Some pixels in the display are darker or brighter than others.	This condition is an inherent characteristic of liquid crystal displays.	This is not a malfunction.
Some menu items cannot be selected.	Some menu items become unavailable while the vehicle is driven.	Park the vehicle in a safe location, and then operate the navigation system.

**NOTE:**

Locations stored in the Address Book and other memory functions may be lost if the vehicle's battery is disconnected or becomes discharged. If this occurs, service the vehicle's battery as necessary and re-enter the information in the Address Book.

### RELATED TO VOICE RECOGNITION

#### Related to Basic Operation

Symptom	Possible cause	Possible solution
The system does not recognize your command. or The system recognizes your command incorrectly	The interior of the vehicle is too noisy.	Close the windows or have other occupants quiet.
	The volume of your voice is too low.	Speak louder.
	The volume if your voice is too loud.	Speak softer.
	Your pronunciation is unclear.	Speak clearly.
	You are speaking before the voice recognition is ready	Press and release "☑" switch on the steering switch, and speak a command after the tone sounds.
	8 seconds or more have passed after you pressed and released "☑" switch on the steering switch.	Make sure to speak a command within 8 seconds after you press and release "☑" switch on the steering switch.
	Only a limited range of voice commands is usable for each screen.	Use a correct voice command appropriate for the current screen.
	The fan of the air conditioner is too loud.	Lower the fan speed as necessary as voice command can be recognized more easily.

#### Related to Item Choice

## NORMAL OPERATING CONDITION

< SYMPTOM DIAGNOSIS >

[INFINITI INTOUCH]

The system should respond correctly to all voice commands without difficulty. If problems are encountered, follow the solutions given in this guide for the appropriate error.

Where the solutions are listed by number, try each solution in turn, starting with number one, until the problem is resolved.

Symptom/ error message	Solution
Displays "COMMAND NOT RECOGNIZED" or the system fails to interpret the command correctly.	1. Ensure that the command format is valid.
	2. Speak clearly without pausing between words and at a level appropriate to the ambient noise level.
	3. Ensure that the ambient noise level is not excessive, for example, windows open or defrost on. <b>NOTE:</b> If it is too noisy to use the phone, it is likely that voice commands will not be recognized.
	4. If optional words of the command have been omitted, then command should be tried with these in place.
The system consistently selects the wrong voicetag	1. Ensure that the voicetag requested matches what was originally stored. This can be confirmed by giving the "Addressbook" Directory or Phone Directory command.
	2. Replace one of the voicetags being confused with a different voicetag.

### Related to Telephone

The system should respond correctly to all voice commands without difficulty. If problems are encountered, try the following solutions.

Where the solutions are listed by number, try each solution in turn, starting with number 1, until the problem is resolved.

Symptom	Solution
System fails to interpret the command correctly.	1. Ensure that the command is valid.
	2. Ensure that the command is spoken after the tone.
	3. Speak clearly without pausing between words and at level appropriate to the ambient noise level in the vehicle.
	4. Ensure that the ambient noise level is not excessive (for example, windows open or defroster on). <b>NOTE:</b> If it is too noisy to use the phone, it is likely that the voice commands will not be recognized.
	5. If more than one command was said at a time, try saying the commands separately.
	6. If the system consistently fails to recognize commands, the voice training procedure should be carried out to improve the recognition response for the speaker. See "Speaker adaptation (SA) mode" earlier in this section. Refer to "OWNER'S MANUAL".
The system consistently selects the wrong voicetag	1. Ensure that the phone book entry name requested matches what was originally stored. This can be confirmed by using the "List Names" command.
	2. Replace one of the names being confused with a new name.

### RELATED TO AUDIO

- The majority of the audio malfunctions are the result of outside causes (bad CD, electromagnetic interference, etc.). Check the symptoms below to diagnose the malfunction.
- The vehicle itself can be a source of noise if noise prevention parts or electrical equipment is malfunctioning. Check if noise is caused and/or changed by engine speed, ignition switch turned to each position, and operation of each piece of electrical equipment, and then determine the cause.

#### **NOTE:**

- CD-R is not guaranteed to play because they can contain compressed audio (MP3, WMA, AAC, M4A) or could be incorrectly mastered by the customer on a computer.
- Check if the CDs carry the Compact Disc Logo. If not, the disc is not mastered to the "red book" Compact Disc Standard and may not play.

# NORMAL OPERATING CONDITION

< SYMPTOM DIAGNOSIS >

[INFINITI INTOUCH]

Symptom	Cause and Counter measure
Cannot play	Check if the CD was inserted correctly.
	Check if the CD is scratched or dirty.
	Check if there is condensation inside the player, and if there is, wait until the condensation is gone (about 1 hour) before using the player.
	If there is a temperature increase error, the player will play correctly after it returns to the normal temperature.
	If there is a mixture of music CD files (CD-DA data) and MP3/WMA/AAC/M4A files on a CD, only the music CD files (CD-DA data) will be played.
	Files with extensions other than ".MP3", ".WMA", ".AAC", ".M4A", ".mp3", ".wma", ".aac" or ".m4a" cannot be played. In addition, the character codes and number of characters for folder names and file names should be in compliance with the specifications.
	Check if the disc or the file is generated in an irregular format, This may occur depending on the variation or the setting of MP3/WMA/AAC/M4A writing applications or other text editing applications.
	Check if the finalization process, such as session close and disc close, is done for the disc.
Poor sound quality	Check if the CD is scratched or dirty.
	Check if the CD is protected by copyright.
It takes a relatively long time before the music starts playing.	Disks recorded in live file system format are not supported. (For Microsoft Windows Vista, check the settings.)
Music cuts off or skips	Check if the finalization process, such as session close and disc close, is done for the disc.
Skipping with high bit rate files	Check if the CD is protected by copyright.
Move immediately to the next song when playing	Disks recorded in live file system format are not supported. (For Microsoft Windows Vista, check the settings.)
The songs do not play back in the desired order.	The writing software and hardware combination might not match, or the writing speed, writing depth, writing width might not match the specifications. Try using the slowest writing speed.
Poor reception only from a certain radio broadcast station.	Skipping may occur with large quantities if data such as for high bit rate data.
Buzz/rattle sound from speaker	When a non-MP3/WMA/AAC/M4A file has been given an extension of ".MP3", ".WMA", ".AAC", ".M4A", ".mp3", ".wma", ".aac" or ".m4a", or when play is prohibited by copyright protection, the player will skip to the next song.
	The playback order is the order in which the files were written by the software, so the files might not play in the desired order.
	Check incoming radio wave signal strength of applicable broadcast station.
	The majority of rattle sounds are not indicative of an issue with the speaker, usually something nearby the speaker is causing the rattle.

Noise resulting from variations in field strength, such as fading noise and multi-path noise, or external noise from trains and other sources, is not a malfunction.

**NOTE:**

- Fading noise: This noise occurs because of variations in the field strength in a narrow range due to mountains or buildings blocking the signal.
- Multi-path noise: This noise results from a time difference between the broadcast waves directly from the station arriving at the antenna and the waves reflected by mountains or buildings.

**RELATED TO VEHICLE ICON**

Symptom	Possible cause	Possible solution
Names of roads differ between Plan View and Birdview™.	This is because the quantity of the displayed information is reduced so that the screen does not become too crowded. There is also a chance that names of the roads may be displayed multiple times, and the names appearing on the screen may be different because of a processing procedure.	This is not a malfunction.

# NORMAL OPERATING CONDITION

< SYMPTOM DIAGNOSIS >

[INFINITI INTOUCH]

Symptom	Possible cause	Possible solution
The vehicle icon is not displayed in the correct position.	The vehicle was transported after the ignition switch was pressed off, for example, by a ferry or car transporter.	Drive the vehicle for a while on a road where GPS signals can be received.
	The position and direction of the vehicle icon may be incorrect depending on the driving environments and the levels of positioning accuracy of the navigation system.	This is not a malfunction. Drive the vehicle for a while to automatically correct the position and direction of the vehicle icon.
When the vehicle is traveling on a new road, the vehicle icon is located on another road nearby.	Because the new road is not stored in the map data, the system automatically places the vehicle icon on the nearest road available.	Updated road information will be included in the next version of the map data.
The screen does not switch to the night screen even after turning on the headlights.	The daytime screen was set the last time the headlights were turned on.	Set the screen to the night screen mode using <Day/Night> when you turn on the headlights.
The map does not scroll even when the vehicle is moving.	The current location map screen is not displayed.	Press "MAP".
The vehicle icon is not displayed.	The current location map screen is not displayed.	Press "MAP".
The location of the vehicle icon is misaligned from the actual position.	When using tire chains or replacing the tires, speed calculations based on the speed sensor may be incorrect.	Drive the vehicle for a while [at approximately 30 km/h (19 MPH) for about 30 minutes] to automatically correct the vehicle icon position. If this does not correct the vehicle icon position, contact an INFINITI dealer.
	The map data has a mistake or is incomplete (the vehicle icon position is always misaligned in the same area).	Updated road information will be included in the next version of the map data.

## RELATED TO ROUTE CALCULATION AND VISUAL GUIDANCE

Symptom	Possible cause	Possible solution
Waypoints are not included in the auto reroute calculation.	Waypoints that you have already passed are not included in the auto reroute calculation.	If you want to go to that waypoint again, you need to edit the route.
Route information is not displayed.	Route calculation has not yet been performed.	Set the destination and perform route calculation.
	You are not driving on the suggested route.	Drive on the suggested route.
	Route guidance is set to off.	Turn on route guidance.
	Route information is not provided for certain types of roads (roads displayed in gray).	This is not a malfunction.
The auto reroute calculation (or detour calculation) suggests the same route as the one previously suggested.	Route calculations took priority conditions into consideration, but the same route was calculated.	This is not a malfunction.
A waypoint cannot be added.	Five waypoints are already set on the route, including ones that you have already passed.	A maximum of 5 waypoints can be set on the route. If you want to go to 6 or more waypoints, perform route calculations multiple times as necessary.
The suggested route is not displayed.	Roads near the destination cannot be calculated.	Reset the destination to a main or ordinary road, and recalculate the route.
	The starting point and destination are too close.	Set a more distant destination.
	The starting point and destination are too far away.	Divide your trip by selecting one or two intermediate destinations, and perform route calculations multiple times.
	There are time restricted roads (by the day of the week, by time) near the current vehicle location or destination.	Set [Use Time Restricted Roads] to off.

## NORMAL OPERATING CONDITION

< SYMPTOM DIAGNOSIS >

[INFINITI INTOUCH]

Symptom	Possible cause	Possible solution
The part of the route that you have already passed is deleted.	A route is managed by sections between waypoints. If you passed the first waypoint, the section between the starting point and the waypoint is deleted. (It may not be deleted depending on the area.)	This is not a malfunction.
An indirect route is suggested.	If there are restrictions (such as one-way streets) on roads close to the starting point or destination, the system may suggest an indirect route.	Adjust the location of the starting of the starting point or destination.
	The system may suggest an indirect route because route calculation does not take into consideration some areas such as narrow streets (gray roads.)	Reset the destination to a main or ordinary road, and recalculate the route.
The landmark information does not correspond to the actual information.	This may be caused by insufficient or incorrect map data.	Updated information will be included in the next version of the data.
The suggested route does not exactly connect to the starting point, waypoints, or destination.	There is no data for route calculation closes to these locations.	Set the starting point, waypoints and destination on a main road, and perform route calculation.

### RELATED TO VOICE GUIDANCE

Symptom	Possible cause	Possible solution
Voice guidance is not available	Voice guidance is only available at certain intersections marked with In some case, voice guidance is not available even when the vehicle should make a turn.	This is not a malfunction.
	The vehicle has deviated from the suggested route.	Go back to the suggested route or request route calculation again
	Voice guide is set to OFF.	Turn ON voice guidance.
	Route guidance is set to OFF.	Turn ON voice guidance.
The guidance contact does not correspond to the actual condition.	The contact of voice guidance may vary, depending on the types of intersections at which turn are made.	Follow all traffic rules and regulations.

### RELATED TO HANDS-FREE PHONE

Symptom	Cause and Counter measure
Does not recognize cellular phone connection. (No connection is displayed on the display at the guide.)	Some Bluetooth enabled cellular phones may not be recognized by the in-vehicle phone module. Refer to "RELATED TO HANDS-FREE PHONE (Check Compatibility)" of MULTI AV SYSTEM SYMPTOM.
Cannot use hands-free phone	Customer will not be able to use a hands-free phone under the following conditions. <ul style="list-style-type: none"> <li>• The vehicle is outside of the telephone service area.</li> <li>• The vehicle is in an area where it is difficult to receive radio waves; such as in a tunnel, in an underground parking garage, near a tall building or in a mountainous area.</li> <li>• The cellular phone is locked to prevent it from being dialed.</li> </ul> <p><b>NOTE:</b> While a cellular phone is connected through the Bluetooth wireless connection, the battery power of the cellular phone may discharge quicker than usual. The Bluetooth Hands-Free Phone System cannot charge cellular phones.</p>
The other party's voice cannot be heard by hands-free phone.	When the radio wave condition is not ideal or ambient sound is too loud, it may be difficult to hear the other person's voice during a call.
Poor sound quality	Do not place the cellular phone in an area surrounded by metal or far away from the in-vehicle phone module to prevent tone quality degradation and wireless connection disruption.

# REMOVAL AND INSTALLATION

## DISPLAY CONTROL UNIT

### Removal and Installation

INFOID:000000013717429

#### REMOVAL

**CAUTION:**

- Before replacing display control unit, perform “Read/Write Configuration” to save or print current vehicle specification. For details, refer to [AV-289, "Description"](#).
- Remove battery terminal and display control unit after a lapse of 30 seconds or more after turning the ignition switch OFF.

**NOTE:**

- After the ignition switch is turned OFF, the display control unit continues operating for approximately 30 seconds. Therefore, data corruption may occur if battery voltage is cut off within 30 seconds.
- Downloaded applications are deleted when display control unit is replaced.

1. Remove the integral switch. Refer to [AV-435, "Removal and Installation"](#).
2. Remove the bracket screws (A).
3. Disconnect the harness connector from the display control unit (1).
4. Remove the bracket from display control unit.

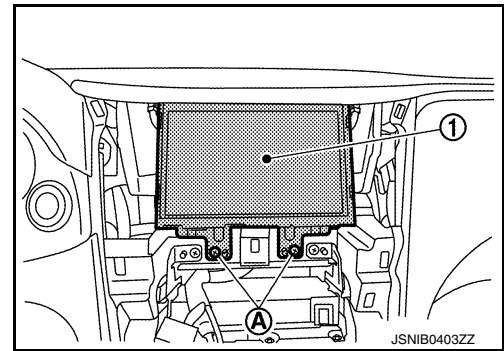

#### INSTALLATION

Install in the reverse order of removal.

**CAUTION:**

Be sure to perform “Read/Write Configuration” when replacing display control unit. For details, refer to [AV-289, "Description"](#).

A  
B  
C  
D  
E  
F  
G  
H  
I  
J  
K  
L  
M  
O  
P

AV

# AV CONTROL UNIT

< REMOVAL AND INSTALLATION >

[INFINITI INTOUCH]

## AV CONTROL UNIT

Exploded View

INFOID:000000013991110

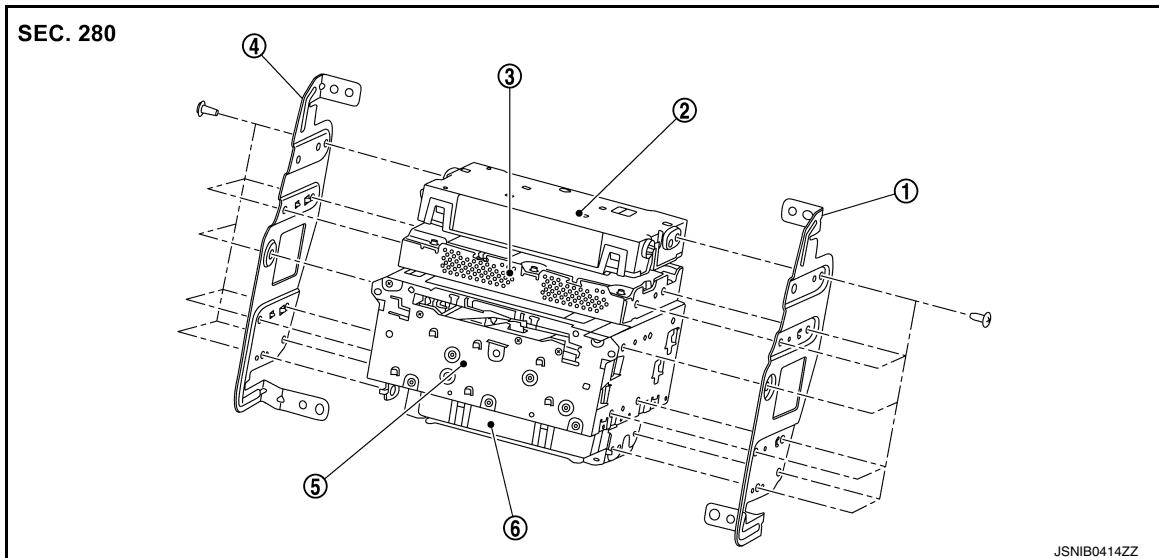

- |              |                   |                     |
|--------------|-------------------|---------------------|
| ① Bracket RH | ② A/C auto amp.   | ③ NAVI control unit |
| ④ Bracket LH | ⑤ AV control unit | ⑥ TCU               |

## Removal and Installation

INFOID:000000013717430

### REMOVAL

#### CAUTION:

- Before replacing AV control unit, perform “Read/Write Configuration” of display control unit to save or print current vehicle specification. For details, refer to [AV-290, "Description"](#).
- Remove battery terminal and AV control unit after a lapse of 30 seconds or more after turning the ignition switch OFF.

#### NOTE:

After the ignition switch is turned OFF, the AV control unit continues operating for approximately 30 seconds. Therefore, data corruption may occur if battery voltage is cut off within 30 seconds.

1. Remove the integral switch. Refer to [AV-435, "Removal and Installation"](#).
2. Remove the bracket screws (A).
3. Disconnect the harness connector from the AV control unit (1).
4. Remove the bracket screws to remove the AV control unit.

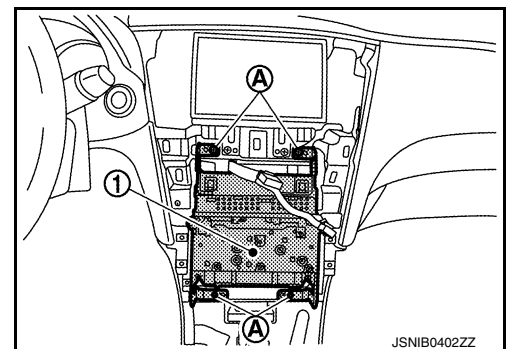

### INSTALLATION

Installation is in the reverse order of removal.

#### CAUTION:

Be sure to perform “Read/Write Configuration” of display control unit when replacing AV control unit. For details, refer to [AV-290, "Description"](#).

# NAVI CONTROL UNIT

< REMOVAL AND INSTALLATION >

[INFINITI INTOUCH]

## NAVI CONTROL UNIT

Exploded View

INFOID:000000013991343

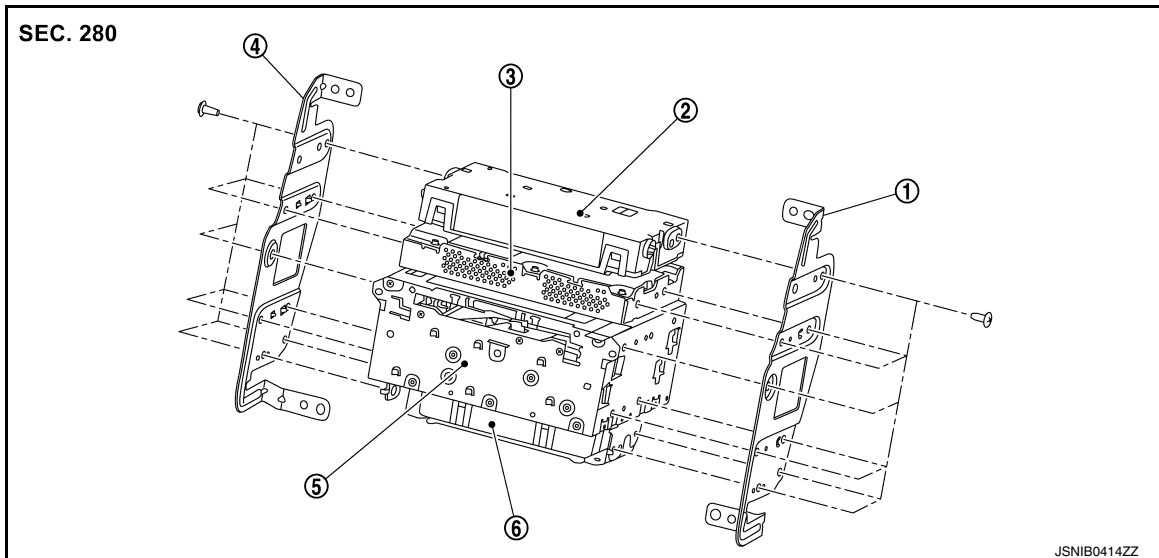

- |              |                   |                     |
|--------------|-------------------|---------------------|
| ① Bracket RH | ② A/C auto amp.   | ③ NAVI control unit |
| ④ Bracket LH | ⑤ AV control unit | ⑥ TCU               |

## Removal and Installation

INFOID:000000013717431

### REMOVAL

#### CAUTION:

- Before replacing NAVI control unit, perform “Read/Write Configuration” of display control unit to save or print current vehicle specification. For details, refer to [AV-291, "Description"](#).
- Remove battery terminal and NAVI control unit after a lapse of 30 seconds or more after turning the ignition switch OFF.

#### NOTE:

After the ignition switch is turned OFF, the NAVI control unit continues operating for approximately 30 seconds. Therefore, data corruption may occur if battery voltage is cut off within 30 seconds.

1. Remove the integral switch. Refer to [AV-435, "Removal and Installation"](#).
2. Remove the bracket screws (A).
3. Disconnect the harness connector from the NAVI control unit (1).
4. Remove the bracket screws to remove the NAVI control unit.

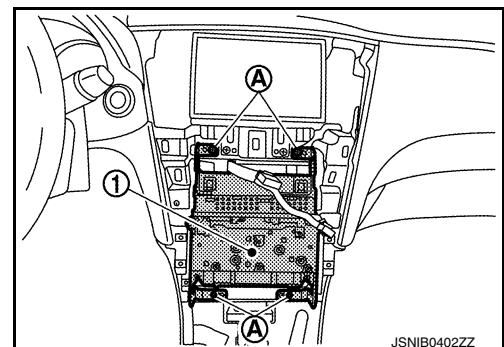

### INSTALLATION

Installation is in the reverse order of removal.

#### NOTE:

Be careful not to install with the top and bottom facing in the wrong directions.

# NAVI CONTROL UNIT

< REMOVAL AND INSTALLATION >

[INFINITI INTOUCH]

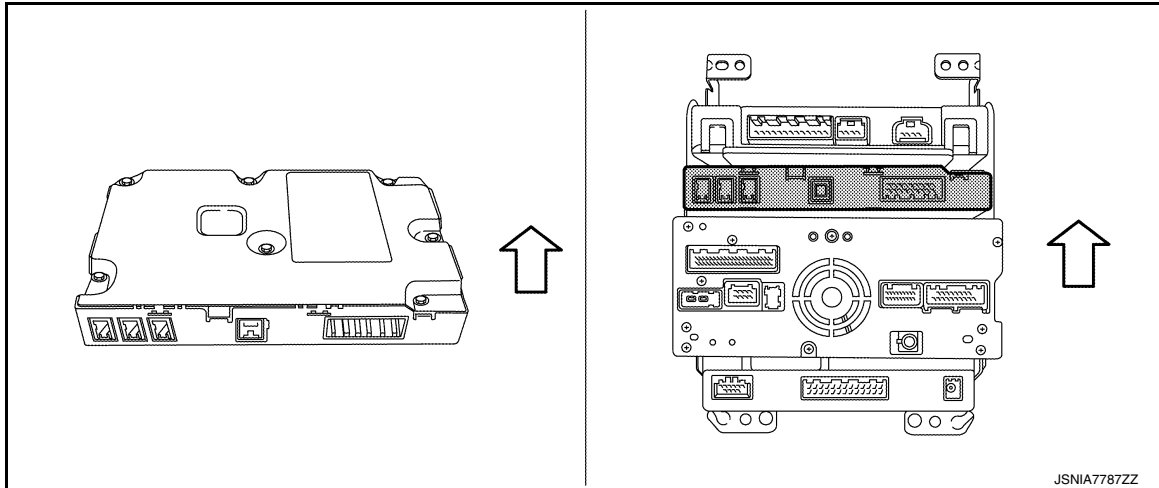

⇐ : Vehicle upper

**CAUTION:**

Be sure to perform "Read/Write Configuration" of display control unit when replacing NAVI control unit. For details, refer to [AV-291, "Description"](#).

# INTEGRAL SWITCH

< REMOVAL AND INSTALLATION >

[INFINITI INTOUCH]

## INTEGRAL SWITCH

### Removal and Installation

INFOID:000000013717432

#### REMOVAL

Remove integral switch. Refer to [JP-13. "Removal and Installation"](#).

#### INSTALLATION

Install in the reverse order of removal.

A

B

C

D

E

F

G

H

I

J

K

L

M

AV

O

P

# MULTIFUNCTION SWITCH

< REMOVAL AND INSTALLATION >

[INFINITI INTOUCH]

## MULTIFUNCTION SWITCH

### Removal and Installation

INFOID:000000013717433

#### REMOVAL

1. Remove the console finisher assembly. Refer to [IP-23. "Removal and Installation"](#).
2. Remove the screws **A** to remove the multifunction switch **1**.

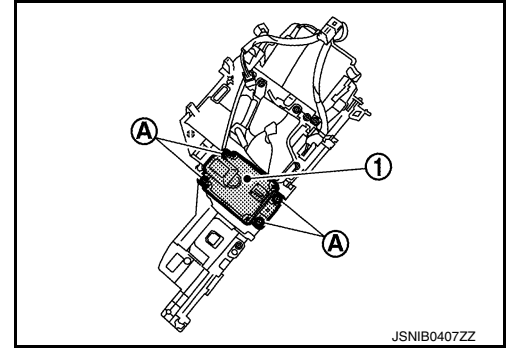

#### INSTALLATION

Installation is in the reverse order of removal.

## EXTERNAL DATA INPUT BOX

### Removal and Installation

INFOID:000000013717434

#### REMOVAL

1. Remove the console box assembly. Refer to [IP-23. "Removal and Installation"](#).
2. Disconnect the harness connector (A).
3. Release the pawls to remove the external data input box ①.

 : Pawl

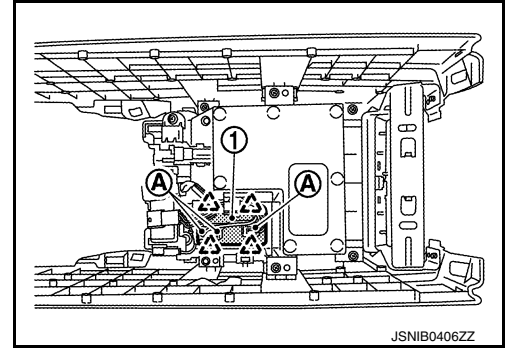

#### INSTALLATION

Installation is in the reverse order of removal.

A  
B  
C  
D  
E  
F  
G  
H  
I  
J  
K  
L  
M  
AV  
O  
P

&lt; REMOVAL AND INSTALLATION &gt;

## BOSE AMP.

## Removal and Installation

INFOID:000000013717435

## REMOVAL

1. Remove the rear side finisher RH. Refer to [INT-23. "REAR SIDE FINISHER : Removal and Installation"](#).
2. Remove the floor carpet assembly ① from pawls (A) and (B).

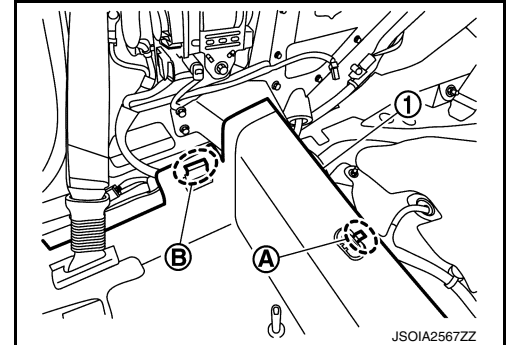

3. Remove bolts (A) and (B) and remove the rear floor gusset RH ①.

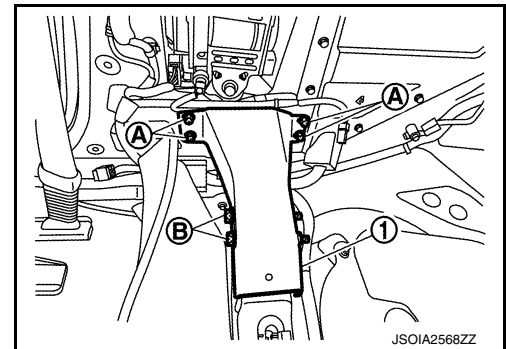

4. Remove the nut (A) and bolts (B) to remove the rear pillar inner reinforcement RH ①.

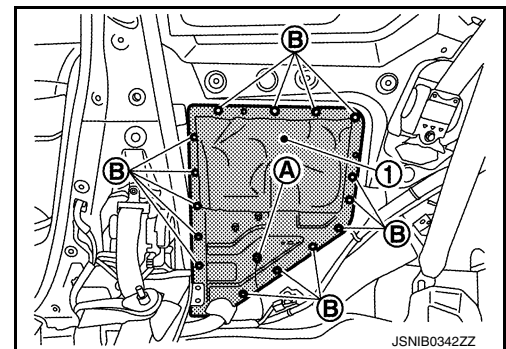

5. Disconnect the connectors (A).
6. Remove the bolts (B) to remove the BOSE amp. ①.

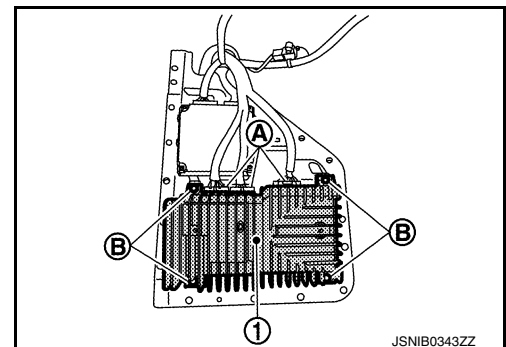

## INSTALLATION

Note the following, and install in the reverse order of removal.

# BOSE AMP.

## < REMOVAL AND INSTALLATION >

[INFINITI INTOUCH]

- Tighten the rear floor gusset RH ① bolts to the specified torque.

**Bolt ① : 35 N·m (3.6 kg-m, 26 ft-lb)**

**Bolt ② : 80 N·m (8.2 kg-m, 59 ft-lb)**

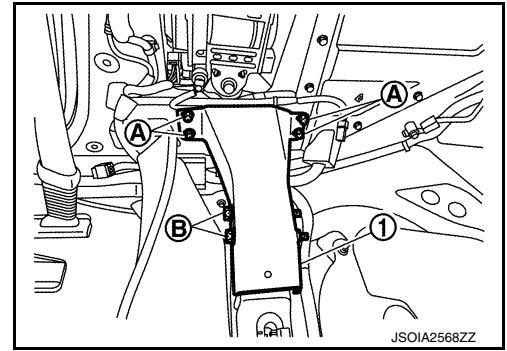

A  
B  
C  
D  
E  
F  
G  
H  
I  
J  
K  
L  
M  
AV  
O  
P

## FRONT SQUAWKER

### Removal and Installation

INFOID:000000013717436

#### REMOVAL

1. Remove the front speaker grille. Refer to [IP-13. "Removal and Installation"](#).
2. Remove the front squawker mounting screws (A).
3. Disconnect the harness connector from the front squawker (1) and remove.

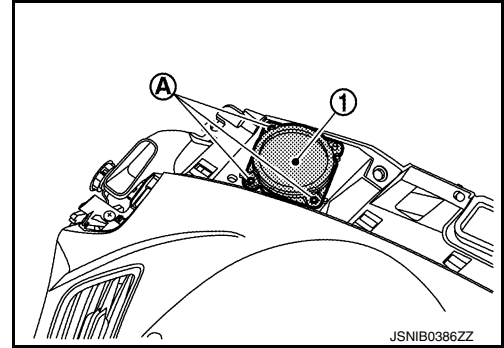

#### INSTALLATION

Installation is in the reverse order of removal.

# CENTER SQUAWKER

< REMOVAL AND INSTALLATION >

[INFINITI INTOUCH]

## CENTER SQUAWKER

### Removal and Installation

INFOID:000000013717437

#### REMOVAL

1. Remove the front speaker grille. Refer to [IP-13, "Removal and Installation"](#).
2. Remove the center squawker mounting screws (A).
3. Disconnect the harness connector from the center squawker ① and remove.

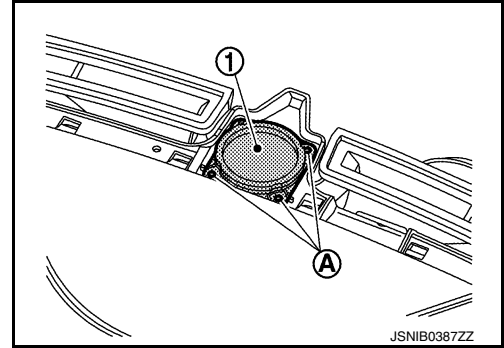

#### INSTALLATION

Installation is in the reverse order of removal.

A  
B  
C  
D  
E  
F  
G  
H  
I  
J  
K  
L  
M  
AV  
O  
P

**TWEETER****Removal and Installation**

INFOID:000000013717438

**REMOVAL**

1. Remove the corner cover. Refer to [MIR-52, "DOOR MIRROR COVER : Removal and Installation"](#) (with ADP) or [MIR-82, "DOOR MIRROR COVER : Removal and Installation"](#) (without ADP).
2. Remove the screws (A) to remove the tweeter (1) from the corner cover.

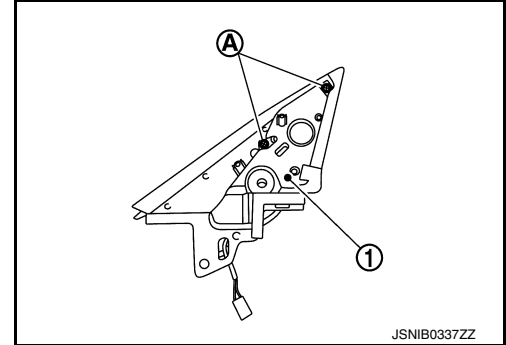

3. Remove the screws (A) to remove the tweeter (1).

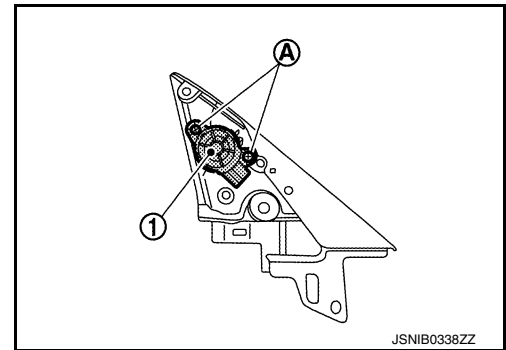
**INSTALLATION**

Installation is the reverse order of removal.

## DOOR SQUAWKER

### Removal and Installation

INFOID:000000013717439

#### REMOVAL

1. Remove the door finisher. Refer to [INT-14, "Removal and Installation"](#).
2. Remove the screws (A) to remove the door squawker (1).

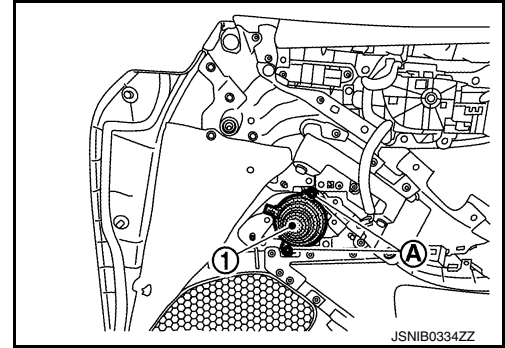

#### INSTALLATION

Install in the reverse order of removal.

A  
B  
C  
D  
E  
F  
G  
H  
I  
J  
K  
L  
M  
O  
P

AV

## DOOR WOOFER

### Removal and Installation

INFOID:000000013717440

#### REMOVAL

1. Remove the door finisher. Refer to [INT-14, "Removal and Installation"](#).
2. Remove the door woofer mounting screws (A).
3. Disconnect the harness connector (B) from the door woofer (1) and remove.

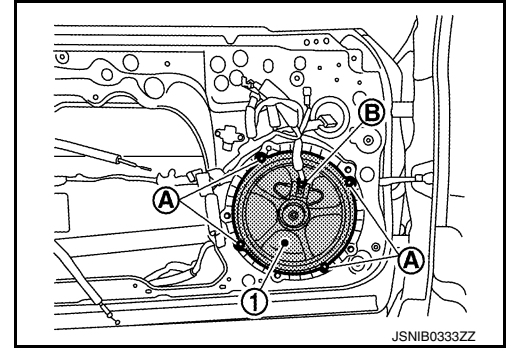

#### INSTALLATION

Install in the reverse order of removal.

## DOOR SPEAKER

### Removal and Installation

INFOID:000000013717444

#### REMOVAL

1. Remove the door finisher. Refer to [INT-14, "Removal and Installation"](#).
2. Remove the door speaker mounting screws (A).
3. Disconnect the harness connector from the door speaker (1) and remove.

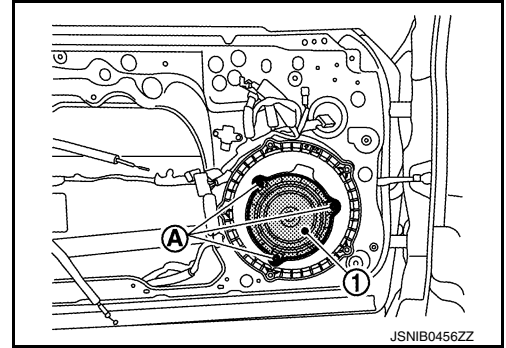

#### INSTALLATION

Install in the reverse order of removal.

A  
B  
C  
D  
E  
F  
G  
H  
I  
J  
K  
L  
M  
AV  
O  
P

## REAR SQUAWKER

### Removal and Installation

INFOID:000000013992002

#### REMOVAL

1. Remove the rear side finisher. Refer to [INT-23. "REAR SIDE FINISHER : Removal and Installation"](#).
2. Remove the screws (A) to remove the rear squawker (1).

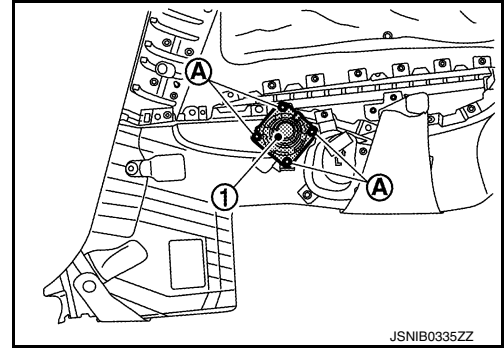

JSNIB0335ZZ

#### INSTALLATION

Install in the reverse order of removal.

## REAR SPEAKER

### Removal and Installation

INFOID:0000000013976118

#### REMOVAL

1. Remove the rear parcel shelf finisher. Refer to [INT-27, "Removal and Installation"](#).
2. Remove the rear speaker mounting bolts (A).
3. Disconnect the harness connector from the rear speaker (1) and remove.

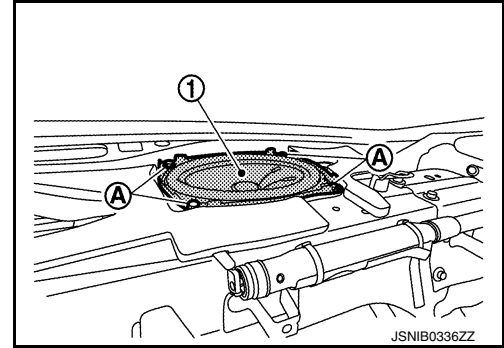

#### INSTALLATION

Install in the reverse order of removal.

A  
B  
C  
D  
E  
F  
G  
H  
I  
J  
K  
L  
M

AV

O  
P

## REAR WOOFER

### Removal and Installation

INFOID:000000013717443

#### REMOVAL

1. Remove the rear parcel shelf finisher. Refer to [INT-27, "Removal and Installation"](#).
2. Remove the rear woofer mounting bolts (A).
3. Disconnect the harness connector from the rear woofer (1) and remove.

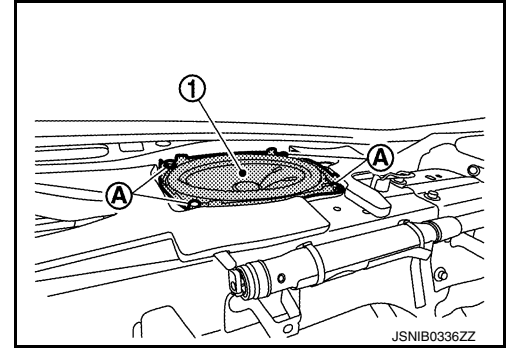

#### INSTALLATION

Install in the reverse order of removal.

# ANTENNA FEEDER

< REMOVAL AND INSTALLATION >

[INFINITI INTOUCH]

## ANTENNA FEEDER

### Feeder Layout

INFOID:000000013717445

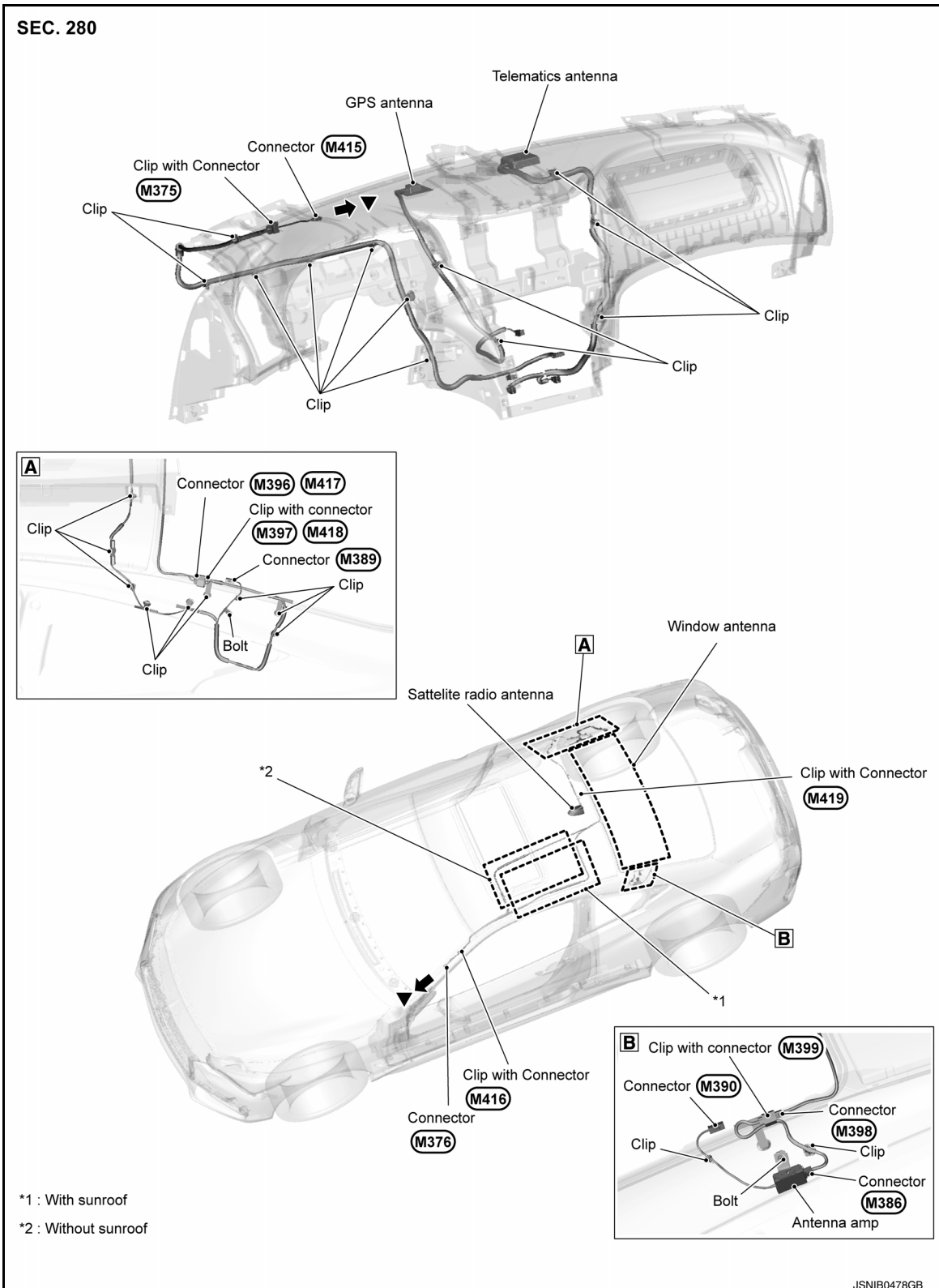

▲: Indicates that the part is connected at points with same symbol in actual vehicle.

A  
B  
C  
D  
E  
F  
G  
H  
I  
J  
K  
L  
M  
AV  
O  
P

# SATELLITE RADIO ANTENNA

< REMOVAL AND INSTALLATION >

[INFINITI INTOUCH]

## SATELLITE RADIO ANTENNA

Exploded View

INFOID:000000013717446

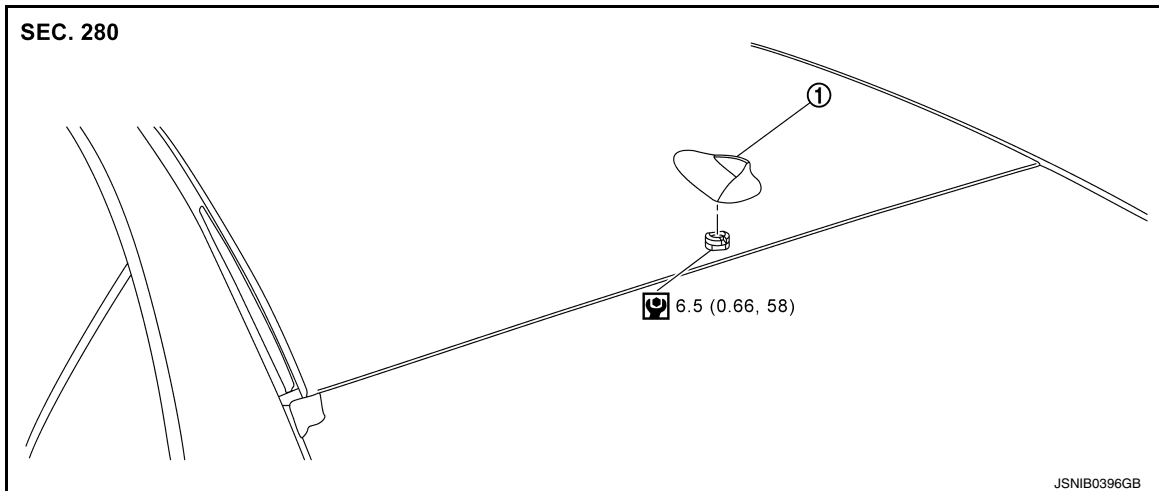

① Satellite radio antenna

 : N·m (kg·m, in·lb)

## Removal and Installation

INFOID:000000013717447

### REMOVAL

1. Remove the headlining assembly. Refer to [INT-35. "Removal and Installation"](#).
2. Disconnect the satellite radio antenna connector (A).
3. Remove the mounting nut (B) to remove the satellite radio antenna (1) from the roof panel.

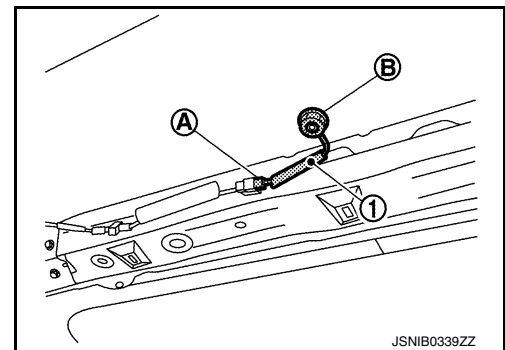

### INSTALLATION

Installation is the reverse order of removal.

#### **CAUTION:**

**Be careful about tightening torque. Antenna sensitivity becomes poor, and when it is excessive, roof panel may be deformed, when satellite radio antenna mounting nut tightening torque is loose.**

## ANTENNA AMP.

### Removal and Installation

INFOID:000000013717448

#### REMOVAL

1. Remove the rear pillar finisher (LH). Refer to [INT-24. "REAR PILLAR FINISHER : Removal and Installation"](#).
2. Disconnect the harness connector (A) from the antenna amp. ①.
3. Disconnect the antenna amp. harness connector (B) from the rear window glass.
4. Remove bolt (C) to remove the antenna amp.

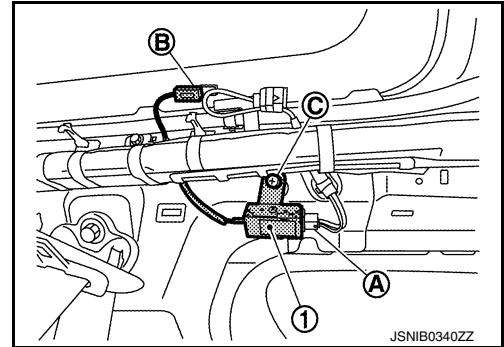

#### INSTALLATION

Installation is the reverse order of removal.

A  
B  
C  
D  
E  
F  
G  
H  
I  
J  
K  
L  
M  
O  
P

AV

## GPS ANTENNA

### Removal and Installation

INFOID:000000013717449

#### REMOVAL

1. Remove the instrument panel assembly. Refer to [IP-13. "Removal and Installation"](#).
2. Remove the screw (A) to remove the GPS antenna (1) from the instrument panel.

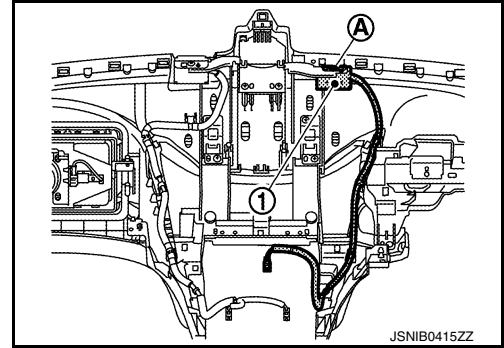

#### INSTALLATION

Install in the reverse order of removal.

# STEERING SWITCH

< REMOVAL AND INSTALLATION >

[INFINITI INTOUCH]

## STEERING SWITCH

### Removal and Installation

INFOID:000000013717450

Refer to [ST-32. "Removal and Installation"](#) (hydraulic pump electric P/S), [ST-81. "Removal and Installation"](#) (electric power steering) or [ST-133. "Removal and Installation"](#) (direct adaptive steering).

**NOTE:**

Always remove steering switch together with steering wheel.

A  
B  
C  
D  
E  
F  
G  
H  
I  
J  
K  
L  
M  
O  
P

AV

## MICROPHONE

### Removal and Installation

INFOID:000000013717451

#### NOTE:

The microphone is integrated with the front microphone.

#### REMOVAL

1. Remove the map lamp assembly. Refer to [INL-76, "MAP LAMP : Removal and Installation"](#).
2. Disconnect the microphone connector (A).
3. Release the pawls to remove the microphone (1).

 : Pawl

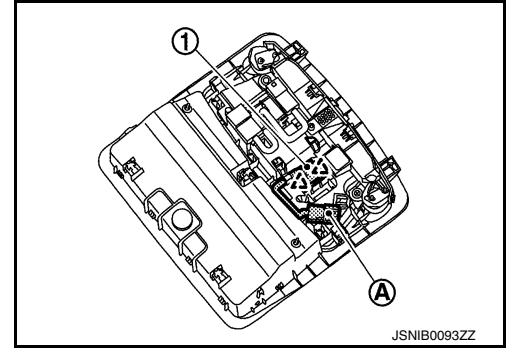

#### INSTALLATION

Installation is in the reverse order of removal.

# ACTIVE NOISE CONTROL UNIT

< REMOVAL AND INSTALLATION >

[INFINITI INTOUCH]

## ACTIVE NOISE CONTROL UNIT

### Removal and Installation

INFOID:000000013717452

#### REMOVAL

1. Remove the rear side finisher RH. Refer to [INT-23. "REAR SIDE FINISHER : Removal and Installation"](#).
2. Remove the floor carpet assembly ① from pawls (A) and (B).

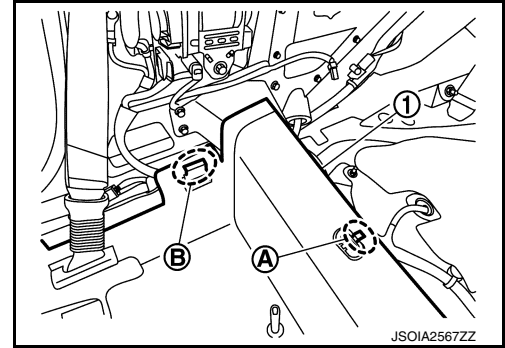

3. Remove bolts (A) and (B) and remove the rear floor gusset RH ①.

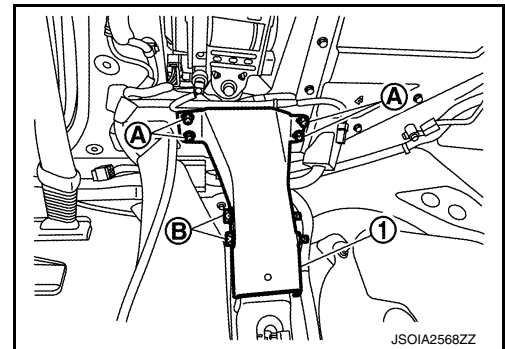

4. Remove the nut (A) and bolts (B).
5. Disconnect harness connector to remove the rear pillar inner reinforcement RH ①.

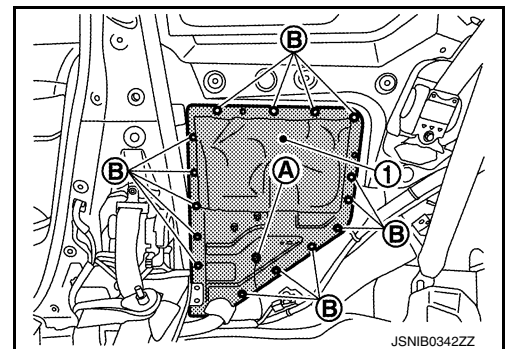

6. Remove the bolts (A) to remove the active noise control unit ①.

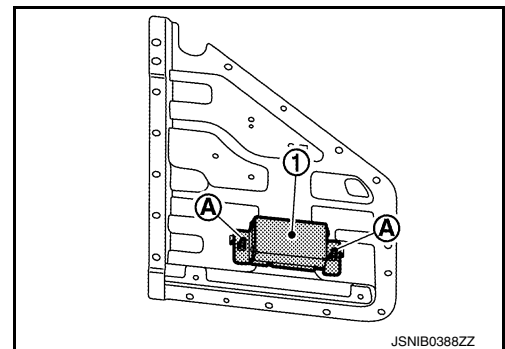

#### INSTALLATION

Note the following, and install in the reverse order of removal.

A  
B  
C  
D  
E  
F  
G  
H  
I  
J  
K  
L  
M  
AV  
O  
P

## ACTIVE NOISE CONTROL UNIT

< REMOVAL AND INSTALLATION >

[INFINITI INTOUCH]

- Tighten the rear floor gusset RH ① bolts to the specified torque.

**Bolt ① : 35 N·m (3.6 kg-m, 26 ft-lb)**

**Bolt ② : 80 N·m (8.2 kg-m, 59 ft-lb)**

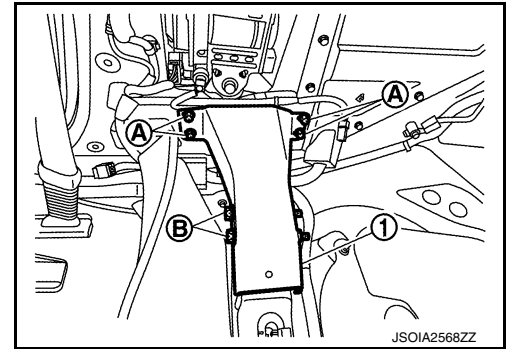

# FRONT MICROPHONE (ACTIVE NOISE CANCELLATION)

< REMOVAL AND INSTALLATION >

[INFINITI INTOUCH]

## FRONT MICROPHONE (ACTIVE NOISE CANCELLATION)

### Removal and Installation

INFOID:000000013717453

#### REMOVAL

1. Remove the headlining assembly. Refer to [INT-35. "Removal and Installation"](#).
2. Disconnect front microphone connector (A).
3. Release the pawls to remove the front microphone (1).

 : Pawl

**CAUTION:**

Carefully handle the pawl fixing the front microphone because the pawl is fragile.

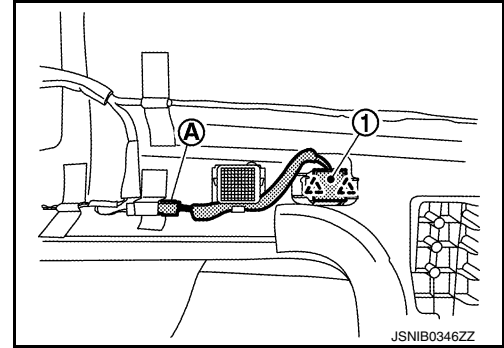

#### INSTALLATION

Installation is in the reverse order of removal.

A  
B  
C  
D  
E  
F  
G  
H  
I  
J  
K  
L  
M

AV

O  
P

# REAR MICROPHONE (ACTIVE NOISE CANCELLATION)

< REMOVAL AND INSTALLATION >

[INFINITI INTOUCH]

## REAR MICROPHONE (ACTIVE NOISE CANCELLATION)

### Removal and Installation

INFOID:000000013717454

#### REMOVAL

1. Remove the rear parcel shelf finisher. Refer to [INT-27, "Removal and Installation"](#).
2. Release the rear microphone finisher pawls to remove the rear microphone ① with the rear microphone finisher attached.

 : Pawl

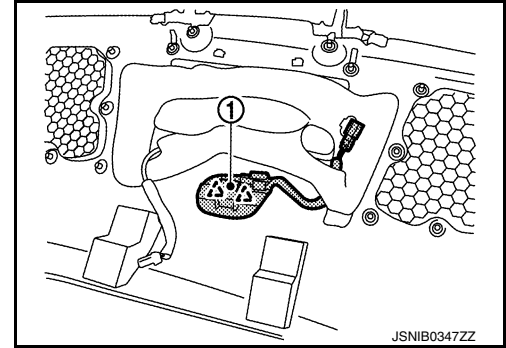

3. Release the rear microphone finisher pawls to remove the rear microphone ①.

 : Pawl

#### **CAUTION:**

Carefully handle the pawl fixing the rear microphone because the pawl is fragile.

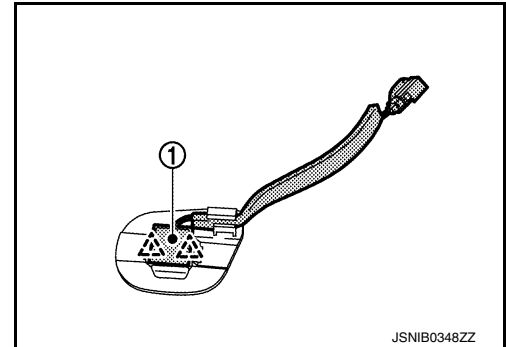

#### INSTALLATION

Installation is the reverse order of removal.

< PRECAUTION >

PRECAUTION

PRECAUTIONS

Precaution for Supplemental Restraint System (SRS) "AIR BAG" and "SEAT BELT PRE-TENSIONER"

INFOID:000000014286301

The Supplemental Restraint System such as "AIR BAG" and "SEAT BELT PRE-TENSIONER", used along with a front seat belt, helps to reduce the risk or severity of injury to the driver and front passenger for certain types of collision. This system includes seat belt switch inputs and dual stage front air bag modules. The SRS system uses the seat belt switches to determine the front air bag deployment, and may only deploy one front air bag, depending on the severity of a collision and whether the front occupants are belted or unbelted. Information necessary to service the system safely is included in the "SRS AIR BAG" and "SEAT BELT" of this Service Manual.

**WARNING:**

Always observe the following items for preventing accidental activation.

- To avoid rendering the SRS inoperative, which could increase the risk of personal injury or death in the event of a collision that would result in air bag inflation, it is recommended that all maintenance and repair be performed by an authorized NISSAN/INFINITI dealer.
- Improper repair, including incorrect removal and installation of the SRS, can lead to personal injury caused by unintentional activation of the system. For removal of Spiral Cable and Air Bag Module, see "SRS AIR BAG".
- Never use electrical test equipment on any circuit related to the SRS unless instructed to in this Service Manual. SRS wiring harnesses can be identified by yellow and/or orange harnesses or harness connectors.

PRECAUTIONS WHEN USING POWER TOOLS (AIR OR ELECTRIC) AND HAMMERS

**WARNING:**

Always observe the following items for preventing accidental activation.

- When working near the Air Bag Diagnosis Sensor Unit or other Air Bag System sensors with the ignition ON or engine running, never use air or electric power tools or strike near the sensor(s) with a hammer. Heavy vibration could activate the sensor(s) and deploy the air bag(s), possibly causing serious injury.
- When using air or electric power tools or hammers, always switch the ignition OFF, disconnect the battery or batteries, and wait at least 3 minutes before performing any service.

Precaution for Battery Service

INFOID:000000014286302

Before disconnecting the battery, lower both the driver and passenger windows. This will prevent any interference between the window edge and the vehicle when the door is opened/closed. During normal operation, the window slightly raises and lowers automatically to prevent any window to vehicle interference. The automatic window function will not work with the battery disconnected.

Precautions for Removing Battery Terminal

INFOID:000000014286303

When disconnecting the battery terminal, pay attention to the following.

- Always use a 12V battery as power source.
- Never disconnect battery terminal while engine is running.
- When removing the 12V battery terminal, turn OFF the ignition switch and wait at least 30 seconds.
- For vehicles with the engine listed below, remove the battery terminal after a lapse of the specified time:

BR08DE	: 4 minutes	YD25DDTi	: 2 minutes
D4D engine	: 20 minutes	YS23DDT	: 4 minutes
HRA2DDT	: 12 minutes	YS23DDTT	: 4 minutes
K9K engine	: 4 minutes	ZD30DDTi	: 60 seconds
M9R engine	: 4 minutes	ZD30DDTT	: 60 seconds
R9M engine	: 4 minutes		
V9X engine	: 4 minutes		

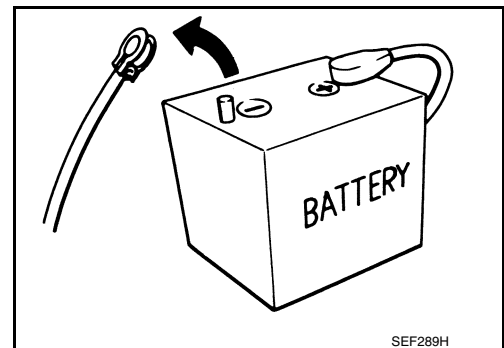

SEF289H

A  
B  
C  
D  
E  
F  
G  
H  
I  
J  
K  
L  
M  
O  
P

AV

# PRECAUTIONS

## [AROUND VIEW MONITOR SYSTEM]

### < PRECAUTION >

#### NOTE:

ECU may be active for several tens of seconds after the ignition switch is turned OFF. If the battery terminal is removed before ECU stops, then a DTC detection error or ECU data corruption may occur.

- After high-load driving, if the vehicle is equipped with the V9X engine, turn the ignition switch OFF and wait for at least 15 minutes to remove the battery terminal.

#### NOTE:

- Turbocharger cooling pump may operate in a few minutes after the ignition switch is turned OFF.
- Example of high-load driving
  - Driving for 30 minutes or more at 140 km/h (86 MPH) or more.
  - Driving for 30 minutes or more on a steep slope.
- For vehicles with the 2-batteries, be sure to connect the main battery and the sub battery before turning ON the ignition switch.

#### NOTE:

If the ignition switch is turned ON with any one of the terminals of main battery and sub battery disconnected, then DTC may be detected.

- After installing the 12V battery, always check "Self Diagnosis Result" of all ECUs and erase DTC.

#### NOTE:

The removal of 12V battery may cause a DTC detection error.

### Precaution for Trouble Diagnosis

INFOID:000000013717457

#### AV COMMUNICATION SYSTEM

- Do not apply voltage of 7.0 V or higher to the measurement terminals.
- Use the tester with its open terminal voltage being 7.0 V or less.
- Be sure to turn ignition switch OFF and disconnect the battery cable from the negative terminal before checking the circuit.

### Precaution for Harness Repair

INFOID:000000013717458

#### AV COMMUNICATION SYSTEM

- Solder the repaired parts, and wrap with tape. [Frays of twisted line must be within 110 mm (4.33 in).]

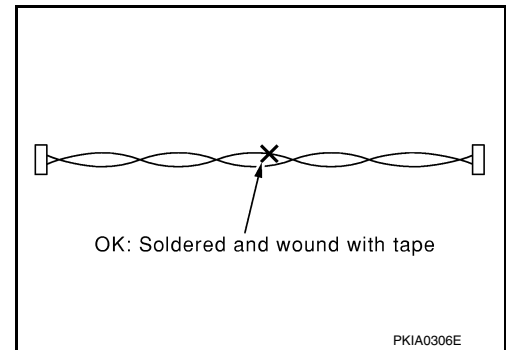

- Do not perform bypass wire connections for the repair parts. (The spliced wire will become separated and the characteristics of twisted line will be lost.)

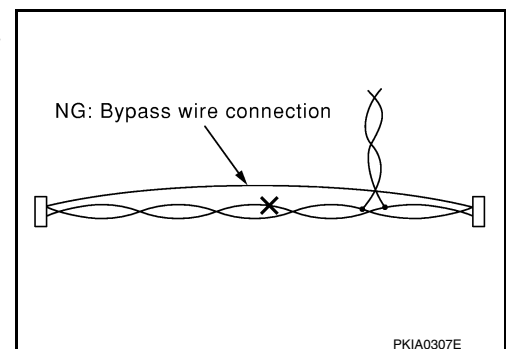

# PREPARATION

< PREPARATION >

[AROUND VIEW MONITOR SYSTEM]

## PREPARATION

### PREPARATION

#### Commercial Service Tools

INFOID:0000000013717459

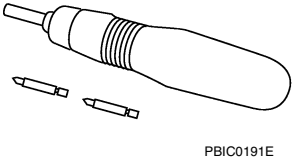
Tool	Description
<p>Power tool</p>  <p>PBIC0191E</p>	<p>Loosening screws</p>

#### Lubricant or/and Sealant

INFOID:0000000013717460

Name	Description	Note
<p>Primer (Sumitomo 3M K520 or equivalent)</p>	<p>Primer for attaching sonar sensor holder to bumper</p>	<p>Sumitomo 3M Limited</p>

A  
B  
C  
D  
E  
F  
G  
H  
I  
J  
K  
L  
M  
O  
P

AV

# COMPONENT PARTS

< SYSTEM DESCRIPTION >

[AROUND VIEW MONITOR SYSTEM]

## SYSTEM DESCRIPTION

### COMPONENT PARTS

#### Component Parts Location

INFOID:000000013717461

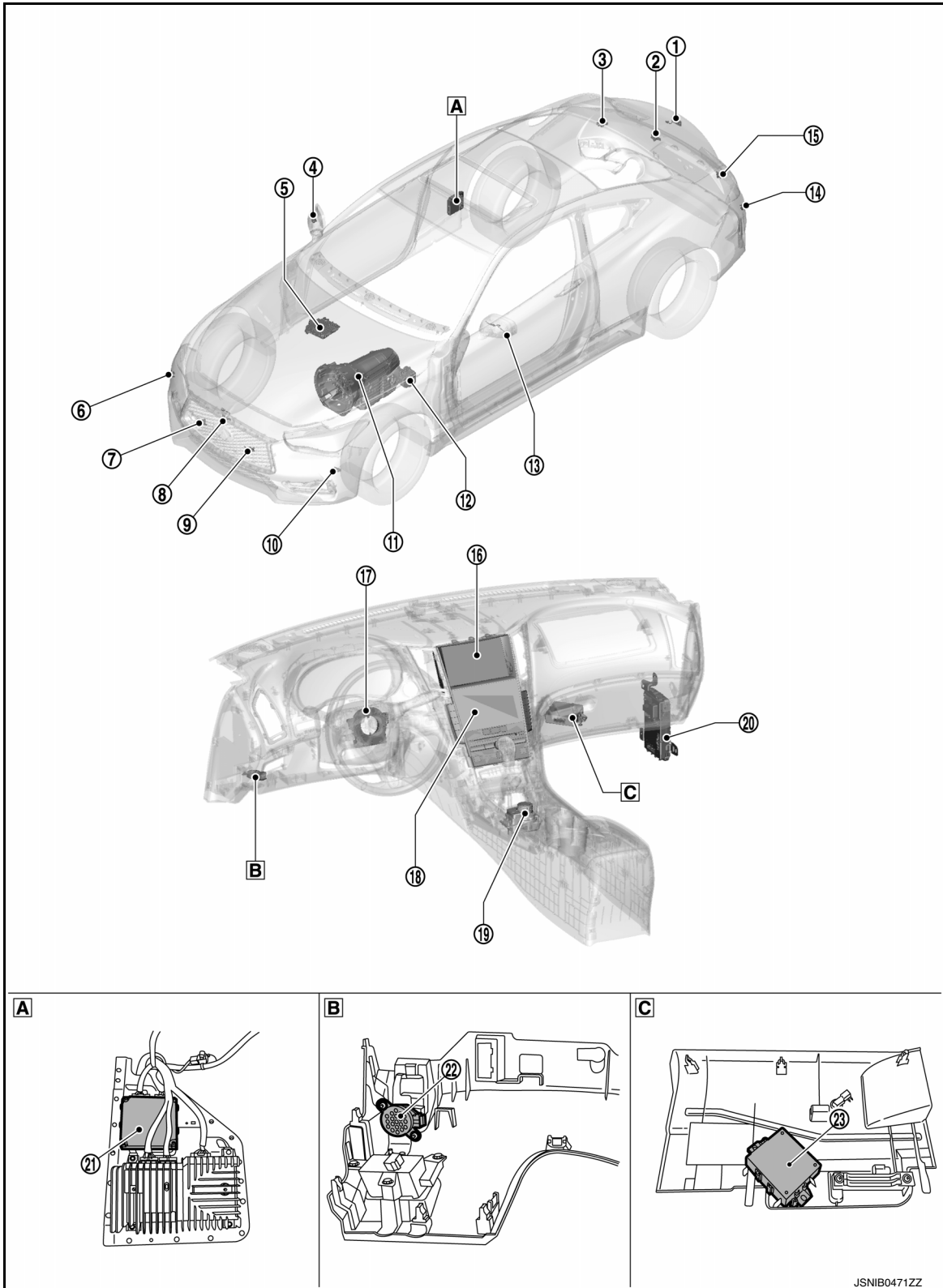

# COMPONENT PARTS

< SYSTEM DESCRIPTION >

[AROUND VIEW MONITOR SYSTEM]

- A Rear pillar inner reinforcement RH removed condition    
 B Instrument lower panel LH removed condition    
 C Instrument lower panel RH removed condition

No.	Component	Function
①	Rear camera	Refer to <a href="#">AV-465, "Rear Camera"</a> .
②	Center sensor rear RH	Refer to <a href="#">AV-465, "Sonar Sensor"</a> .
③	Corner sensor rear RH	Refer to <a href="#">AV-465, "Sonar Sensor"</a> .
④	Side camera RH	Refer to <a href="#">AV-464, "Side Camera"</a> .
⑤	ECM	Transmits the shift position signal to the around view monitor control unit. (2.0L turbo gasoline engine models) Refer to <a href="#">EC4-25, "ENGINE CONTROL SYSTEM : Component Parts Location"</a> , for detailed installation location.
⑥	Corner sensor front RH	Refer to <a href="#">AV-465, "Sonar Sensor"</a> .
⑦	Center sensor front RH	Refer to <a href="#">AV-465, "Sonar Sensor"</a> .
⑧	Front camera	Refer to <a href="#">AV-464, "Front Camera"</a> .
⑨	Center sensor front LH	Refer to <a href="#">AV-465, "Sonar Sensor"</a> .
⑩	Corner sensor front LH	Refer to <a href="#">AV-465, "Sonar Sensor"</a> .
⑪	TCM	Transmits the shift position signal to the around view monitor control unit. (VR30DDTT engine models) Refer to <a href="#">TM-14, "A/T CONTROL SYSTEM : Component Parts Location"</a> , for detailed installation location.
⑫	ABS actuator and electric unit (control unit)	Transmits the following signals to the display control unit. <ul style="list-style-type: none"> <li>• Vehicle speed signal</li> <li>• Rear LH wheel speed signal</li> <li>• Rear RH wheel speed signal</li> </ul> Refer to <a href="#">BRC-11, "Component Parts Location"</a> , for detailed installation location.
⑬	Side camera LH	Refer to <a href="#">AV-464, "Side Camera"</a> .
⑭	Corner sensor rear LH	Refer to <a href="#">AV-465, "Sonar Sensor"</a> .
⑮	Center sensor rear LH	Refer to <a href="#">AV-465, "Sonar Sensor"</a> .
⑯	Display control unit	<ul style="list-style-type: none"> <li>• Camera image signal that is received from around view monitor control unit is displayed in the display.</li> <li>• Transmits the following signals to the around view monitor control unit.</li> <li>- Camera switch signal</li> </ul>
⑰	Steering angle sensor	Refer to <a href="#">AV-466, "Steering Angle Sensor"</a> .
⑱	Integral switch	Push switch B signal and camera switch signal are transmitted from integral switch to the display control unit.
⑲	Multifunction switch	When the "CAMERA" switch is pressed, the push switch B signal is transmitted to integral switch.
⑳	BCM	Transmits the following signals to the around view monitor control unit. <ul style="list-style-type: none"> <li>• Door switch signal</li> <li>• Trunk switch signal</li> </ul> Refer to <a href="#">BCS-5, "BODY CONTROL SYSTEM : Component Parts Location"</a> , for detailed installation location.
㉑	Around view monitor control unit	Refer to <a href="#">AV-464, "Around View Monitor Control Unit"</a> .
㉒	Buzzer	Refer to <a href="#">AV-466, "Buzzer"</a> .
㉓	Sonar control unit	Refer to <a href="#">AV-465, "Sonar Control Unit"</a> .

# COMPONENT PARTS

< SYSTEM DESCRIPTION >

[AROUND VIEW MONITOR SYSTEM]

## Around View Monitor Control Unit

INFOID:000000013717462

- The around view monitor control unit is installed to the rear pillar inner reinforcement RH.
- Necessary signals are transmitted/received to/from control unit via CAN communication.
- Necessary signals are transmitted/received to/from display control unit via AV communication.
- Camera image signals received from each camera are converted/synthesized in the around view monitor control unit and transmitted to the display control unit.
- Vehicle width guide lines, predicted course line, vehicle front guiding line and vehicle side line, tire icon, and vehicle icon are rendered with the around view monitor control unit and combined with camera image.

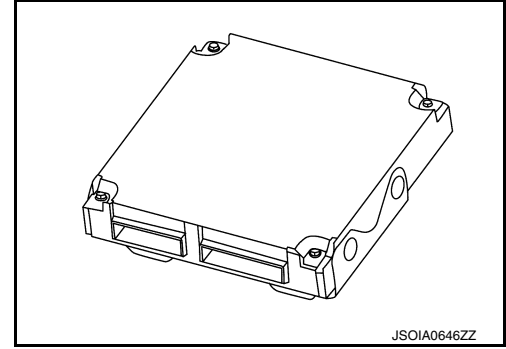

## Front Camera

INFOID:000000013717463

- The front camera is installed to the front grille.
- Super-small CMOS camera (color) using CMOS\* for the image pickup element is adopted.
- Power for the camera is supplied from the around view monitor control unit, and the image at the front of the vehicle is sent to the around view monitor control unit.

**NOTE:**

\*: "CMOS" is abbreviation of Complementary Metal Oxide Semiconductor, and features low power consumption and high speed reading rate of electric charge.

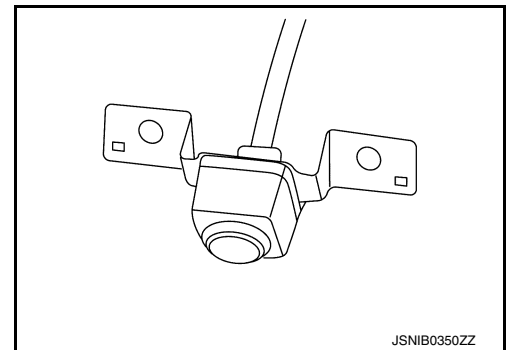

## Specification

Image pickup element	1/3.8-inch CMOS image sensor
Effective number of pixels	Approx. 1280,000 pixels (1296 × 985)
Minimum brightness	2 lx
Angle of view	Horizontal view angle: 154° Vertical view angle: 96°

## Side Camera

INFOID:000000013717464

- The side camera is installed to the door mirror.
- Super-small CMOS camera (color) using CMOS\* for the image pickup element is adopted.
- Power for the camera is supplied from the around view monitor control unit, and the image at the side of the vehicle is sent to the around view monitor control unit.

**NOTE:**

\*: "CMOS" is abbreviation of Complementary Metal Oxide Semiconductor, and features low power consumption and high speed reading rate of electric charge.

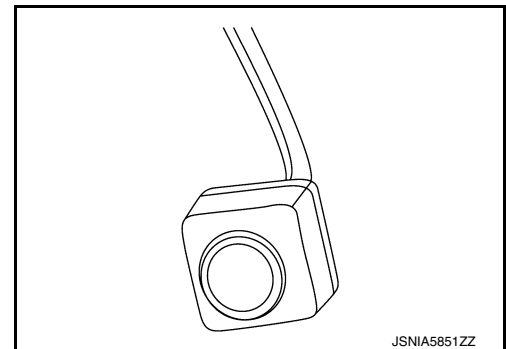

## Specification

Image pickup element	1/3.8-inch CMOS image sensor
Effective number of pixels	Approx. 1280,000 pixels (1296 × 985)
Minimum brightness	2 lx
Angle of view	Horizontal view angle: 154° Vertical view angle: 96°

# COMPONENT PARTS

## [AROUND VIEW MONITOR SYSTEM]

< SYSTEM DESCRIPTION >

### Rear Camera

INFOID:000000013717465

- The rear camera is installed at the center of the trunk lid.
- Super-small CMOS camera (color) using CMOS\* for the image pickup element is adopted.
- With the mirror processing function, a mirror image is sent as if it is viewed by a rear view mirror.
- Power for the camera is supplied from the around view monitor control unit, and the image at the rear of the vehicle is sent to the around view monitor control unit.

**NOTE:**

\*: "CMOS" is abbreviation of Complementary Metal Oxide Semiconductor, and features low power consumption and high speed reading rate of electric charge.

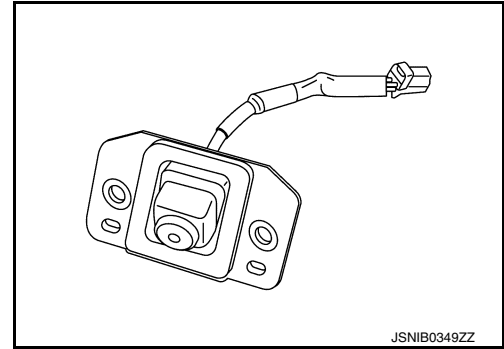

JSNIB0349ZZ

### Specification

Image pickup element	1/3.8-inch CMOS image sensor
Effective number of pixels	Approx. 1280,000 pixels (1296 × 985)
Minimum brightness	2 lx
Angle of view	Horizontal view angle: 154° Vertical view angle: 96°
Image	With the mirror processing function

### Sonar Control Unit

INFOID:000000013717466

- Sonar control unit is located on the passenger instrument lower panel.
- Necessary signals are transmitted/received to/from control unit via CAN communication.
- The tone outputs by inputting the sensor signal from sonar sensors. The tone outputs the each speaker.
- Sensor signal that corresponds to the detected distance to an obstacle is transmitted to around view monitor control unit via CAN communication, and the sonar indicator is displayed on display control unit. Refer to [AV-467. "System Description"](#).

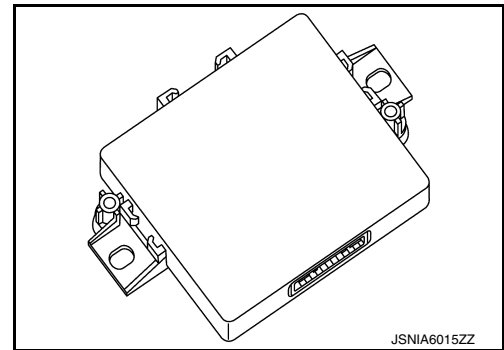

JSNIA6015ZZ

### Sonar Sensor

INFOID:000000013717467

When a distance from an obstacle is detected, a distance signal is transmitted to the sonar control unit.

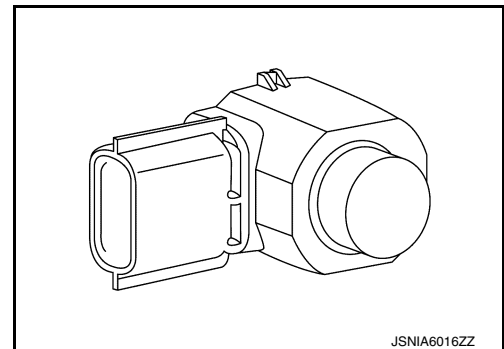

JSNIA6016ZZ

A  
B  
C  
D  
E  
F  
G  
H  
I  
J  
K  
L  
M  
AV  
O  
P

## COMPONENT PARTS

< SYSTEM DESCRIPTION >

[AROUND VIEW MONITOR SYSTEM]

### Buzzer

INFOID:000000013717468

The MOD buzzer sounds with the signal from the sonar control unit.

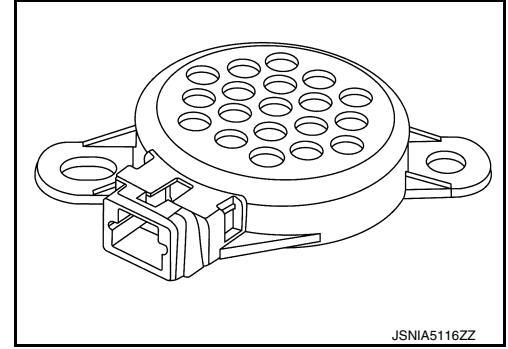

### Steering Angle Sensor

INFOID:000000013717469

- Steering angle sensor is installed to the spiral cable.
- Steering angle sends the steering signal necessary for predictive course line of the front or rear view monitor to the around view monitor control unit via CAN communication.

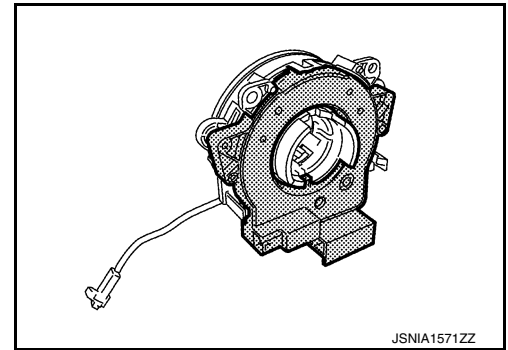

# AROUND VIEW MONITOR SYSTEM

< SYSTEM DESCRIPTION >

[AROUND VIEW MONITOR SYSTEM]

## AROUND VIEW MONITOR SYSTEM

### System Description

INFOID:000000013717470

### SYSTEM DIAGRAM

#### VR30DDTT Engine Models

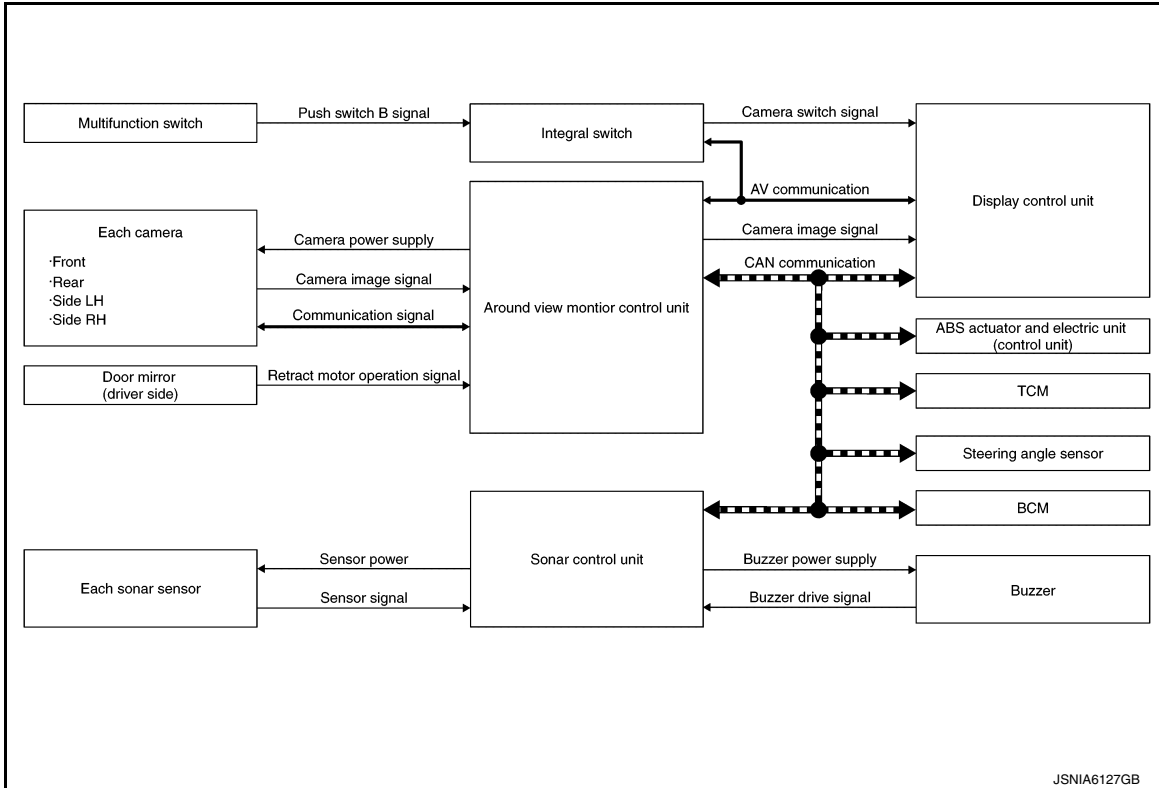

#### 2.0L Turbo Gasoline Engine Models

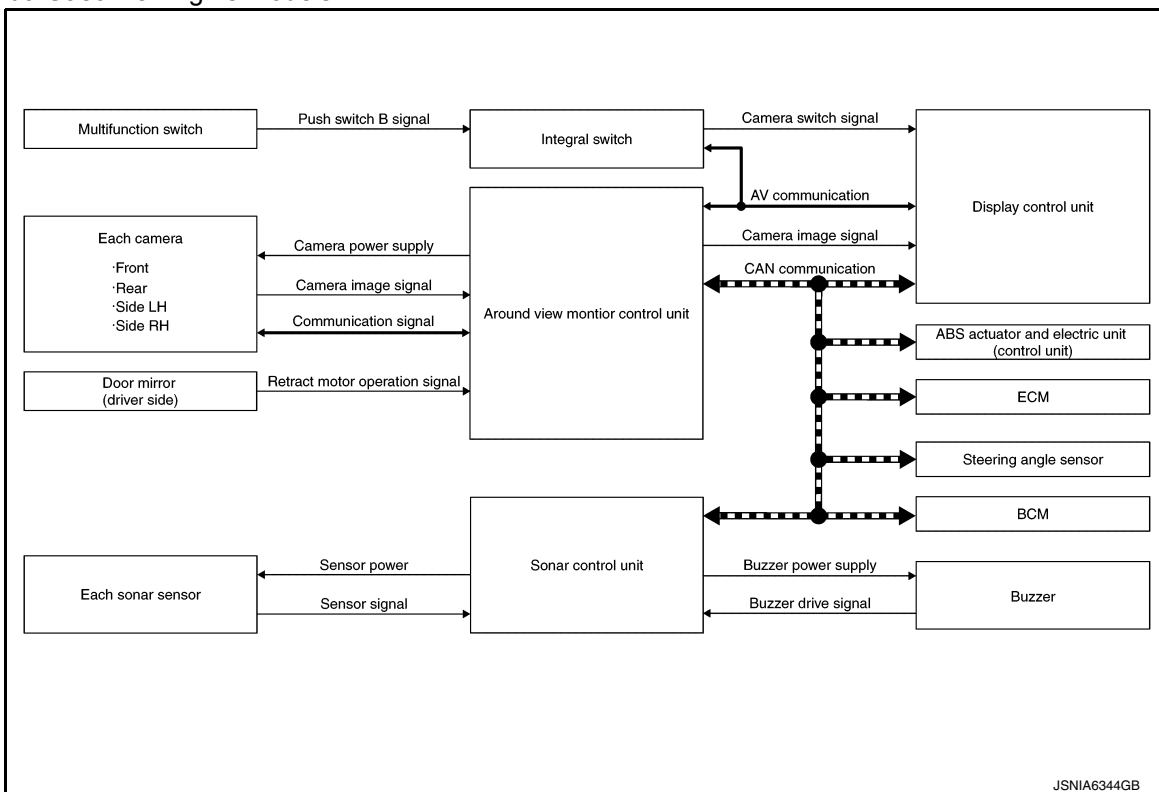

A  
B  
C  
D  
E  
F  
G  
H  
I  
J  
K  
L  
M  
N  
O  
P

AV

# AROUND VIEW MONITOR SYSTEM

< SYSTEM DESCRIPTION >

[AROUND VIEW MONITOR SYSTEM]

## Around View Monitor Control Unit Input Signal (CAN Communication)

Transmit unit	Signal name
Steering angle sensor	Steering angle sensor signal
TCM (VR30DDTT)	Shift position signal
ECM (2.0L turbo gasoline engine)	
ABS actuator and electric unit (control unit)	Vehicle speed signal
	Rear LH wheel speed signal
	Rear RH wheel speed signal
BCM	Door switch signal
	Trunk switch signal
Sonar control unit	Sonar status signal
Display control unit	Camera switch signal

## Around View Monitor Control Unit Output Signal (CAN Communication)

Transmit unit	Signal name
Display control unit	View change signal
Sonar control unit	MOD beep sound output request signal

## Sonar Control Unit Input Signal (CAN Communication)

Transmit unit	Signal name
TCM (VR30DDTT)	Shift position signal
ECM (2.0L turbo gasoline engine)	
ABS actuator and electric unit (control unit)	Vehicle speed signal

## DESCRIPTION

- This system is equipped with wide-angle high-resolution cameras on the front and rear of the vehicle and on both right and left door mirrors. The images from front view, rear view, front-side view RH side, and birds-eye view that shows the view from the top of the vehicle are displayed to monitor the vehicle surroundings.
- Around view monitor control unit cuts out and expands the image received from each camera to create each view.
- The sonar indicator is displayed on display (superimposed on the camera image) in combination with the camera assistance sonar system to warn of the approach of an obstacle.
- Camera image is displayed on the display when an obstacle is detected by sonar system.
- In front view and rear view, the vehicle width, distance lines and predictive course lines are superimposed and displayed. In front-side view, the vehicle distance guiding line and vehicle width guiding line are displayed.
- The Birds-Eye view converts the images from 4 cameras into the overhead view and displays the status of the vehicle on display. The vehicle icon and sonar indicator that are displayed on the Birds-Eye view display are rendered by around view monitor control unit.
- Moving Object Detection (MOD) is adopted that detects moving objects according to camera image and notifies the detection result to the driver.
- Tire icon is adopted for Birds-Eye view image.
- Front wide view function is adopted. Visibility for the left and right that contains invisible area is improved.

## AROUND VIEW MONITOR SCREEN

- Around view monitor combines and displays the travel direction view and “Birds-Eye view”, “Front-Side view” and then it displays the sonar indicator on the “Birds-Eye view”, “Front-Side view”, “Front wide view”.
- Display control unit renders the “Change View” switch, view icon, warning message on display.

# AROUND VIEW MONITOR SYSTEM

< SYSTEM DESCRIPTION >

[AROUND VIEW MONITOR SYSTEM]

## Screen constitution

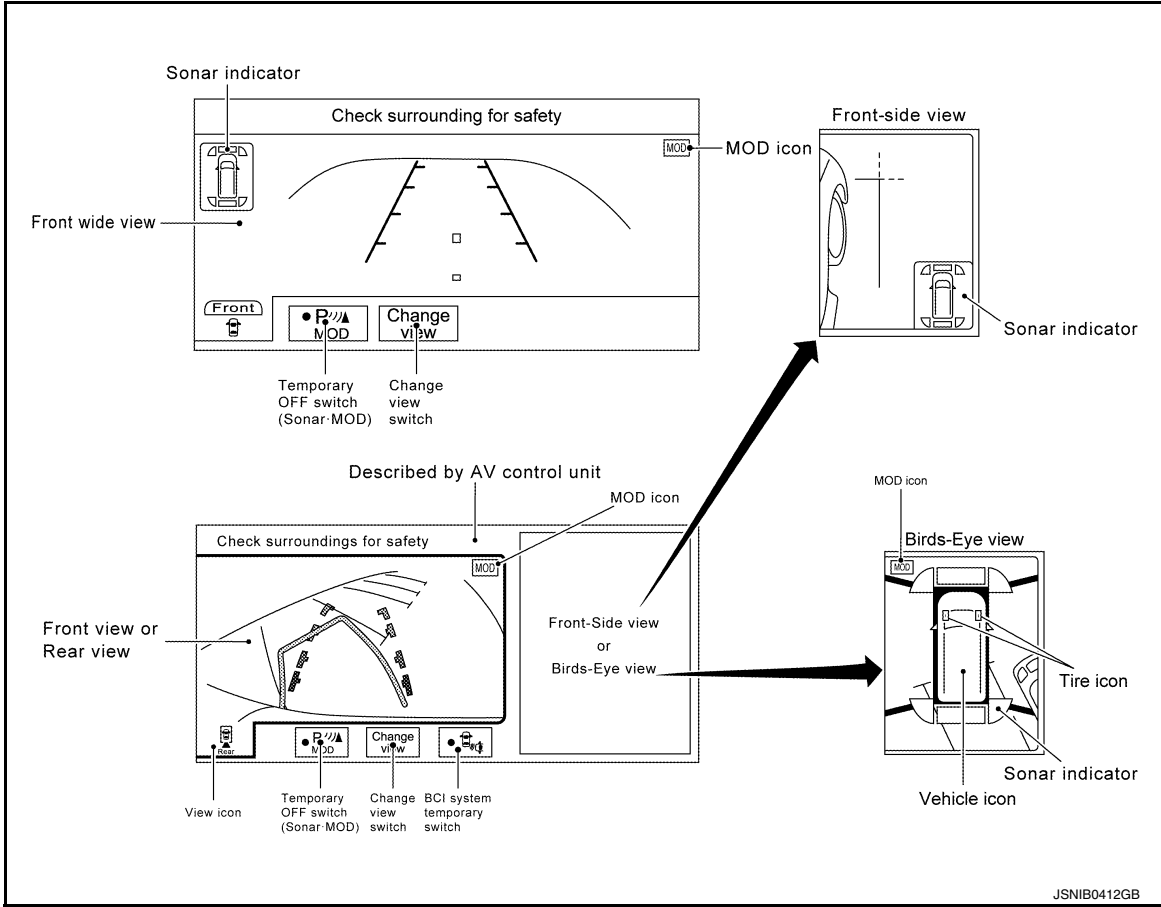

## OPERATION DESCRIPTION

A  
B  
C  
D  
E  
F  
G  
H  
I  
J  
K  
L  
M  
N  
O  
P

AV

# AROUND VIEW MONITOR SYSTEM

< SYSTEM DESCRIPTION >

[AROUND VIEW MONITOR SYSTEM]

## Around view monitor screen transition

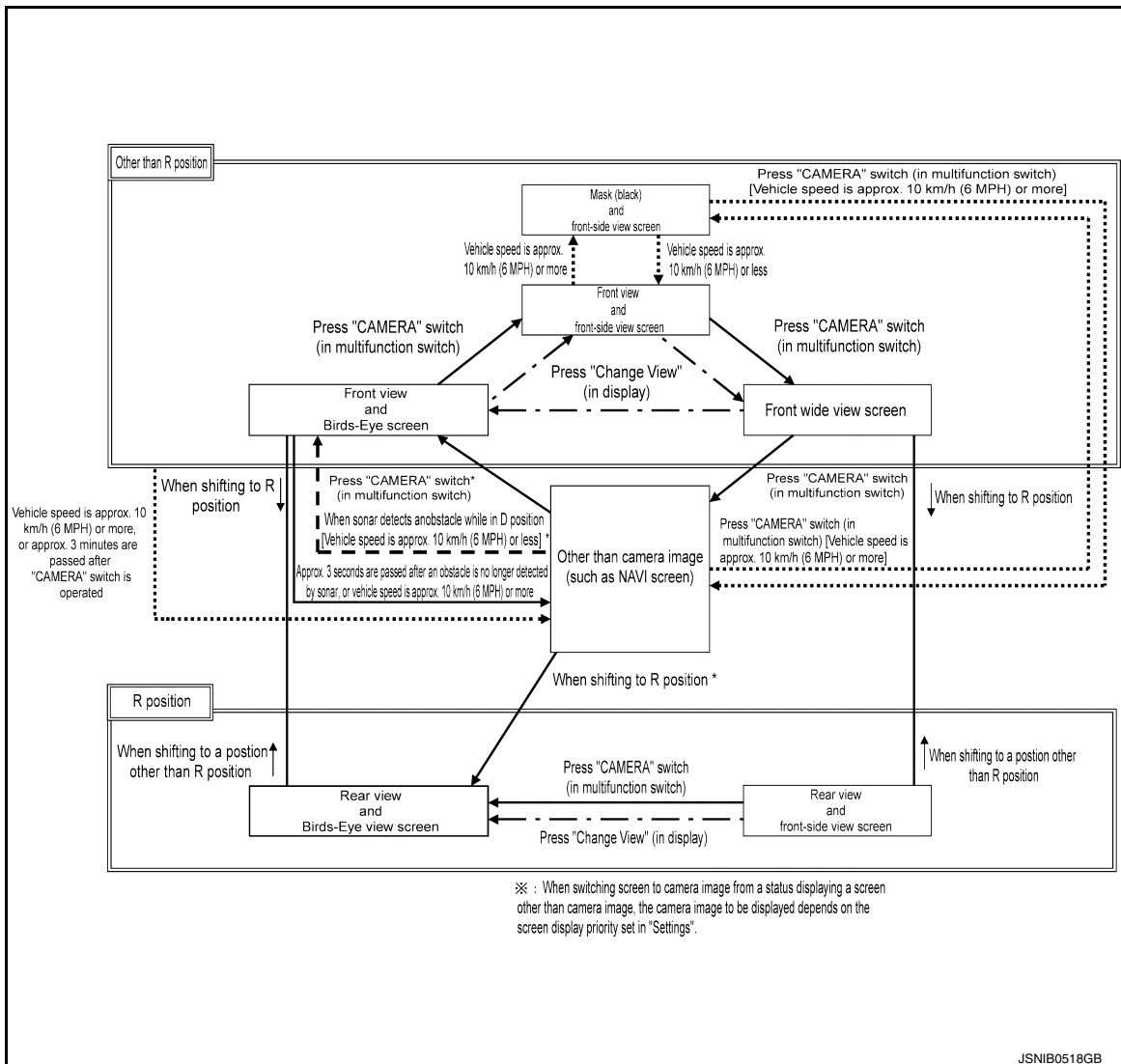

- Around view monitor is displayed on the display when "CAMERA" switch is pressed, when shifting position is reverse, or when an obstacle is detected by sonar system.
- Birds-Eye view, Front-side view, and front wide view can be switched by "Change View" switch (touch switch) or "CAMERA" switch, while around view monitor is displayed.
- Priority of view to be displayed can be set by "Settings" screen.
- While shift position is other than reverse, around view monitor is cancelled when approximately 3 minutes are passed after "CAMERA" switch is pressed, or when vehicle speed is approximately 10 km/h (6 MPH) or more. The screen returns to the screen before displaying around view monitor.
- Setting of Moving Object Detection (MOD) and sonar can be switched ON/OFF by temporary OFF switch of display control unit. (Temporary OFF)
- In temporary OFF, around view monitor is cancelled. Temporary OFF is cancelled when around view monitor is displayed once again. Sonar and MOD are switched to operation-ready status
- In permanent OFF, MOD and sonar are not operative until MOD and sonar are switched to ON by "Settings" screen.
- In Birds-Eye view, an enhanced boundary is displayed on the image indicating the invisible area and clearly indicating the boundary of the 4 cameras. The invisible area is displayed in yellow when Birds-Eye view is displayed after the ignition switch is turned ON.
- In D position, front sonar can detect an obstacle while camera image is not displayed on display control unit. Screen is switched to camera image when an obstacle is detected.
- If information of camera and information written to around view monitor control unit are not the same, error indicator of applicable camera position is displayed when Birds-Eye view is displayed.
- When "CAMERA" switch of multifunction switch is pressed, it receives camera switch signal from display control unit via AV communication.

# AROUND VIEW MONITOR SYSTEM

## [AROUND VIEW MONITOR SYSTEM]

### < SYSTEM DESCRIPTION >

- When around view monitor control unit receives camera switch signal, around view monitor control unit reads the image signal from each camera.
- When around view monitor control unit receives reverse signal, while shift position is R position, around view monitor control unit reads image signal from each camera.
- When around view monitor control unit reads image signal from each camera, it cuts out the required screen for each view, superimposes camera image, vehicle icon, guiding lines, predicted course line, "MOD" icon, and sonar indicator, and then outputs them to display control unit.

#### Front View

- The front view image is from the front camera.
- When the selector lever is in any position other than the reverse position, the front view is displayed by pressing the "CAMERA" switch. It improves the visibility of obstacles in front of the vehicle and helps driving by the images displayed from Birds-Eye view and Front-Side view. The front wide view function allows the display of an image with a 180° horizontal angle.
- Display the vehicle width guiding line and vehicle distance guiding line in front view and display the predictive course line according to the steering angle.
- If the steering angle is within approximately 90 degrees, the predictive course lines on the left/right side are displayed. If the steering angle is exceeding approximately 90 degrees, only the predictive course line on the outside (in the opposite side of steering direction) is displayed.
- Around view monitor control unit is connected to the steering angle sensor and receives the steering angle signal via CAN communication.
- Around view monitor control unit controls the direction and distance of the predictive course line according to the sensor signal from steering angle sensor.

Front view guiding lines

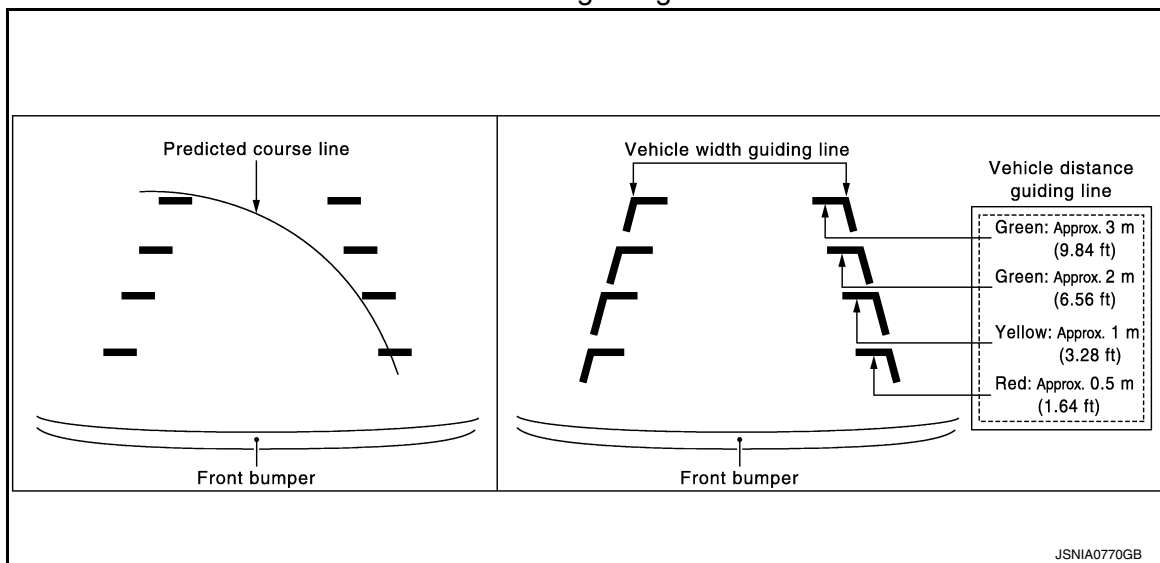

#### Rear View

- The rear view image is from the rear camera.
- When the selector lever is in the reverse position, the rear view is displayed. Backing and parking are improved by the images from Birds-Eye view and Front-Side view.
- Display the vehicle width guiding line and vehicle distance guiding line in Rear view and display the predictive course line according to the steering angle.
- The predictive course line is not displayed at the steering neutral position.
- Around view monitor control unit is connected to the steering angle sensor and receives the steering angle signal via CAN communication.
- Around view monitor control unit controls the direction and distance of predictive course line according to the sensor signal from steering angle sensor.

# AROUND VIEW MONITOR SYSTEM

< SYSTEM DESCRIPTION >

[AROUND VIEW MONITOR SYSTEM]

Rear view guiding lines

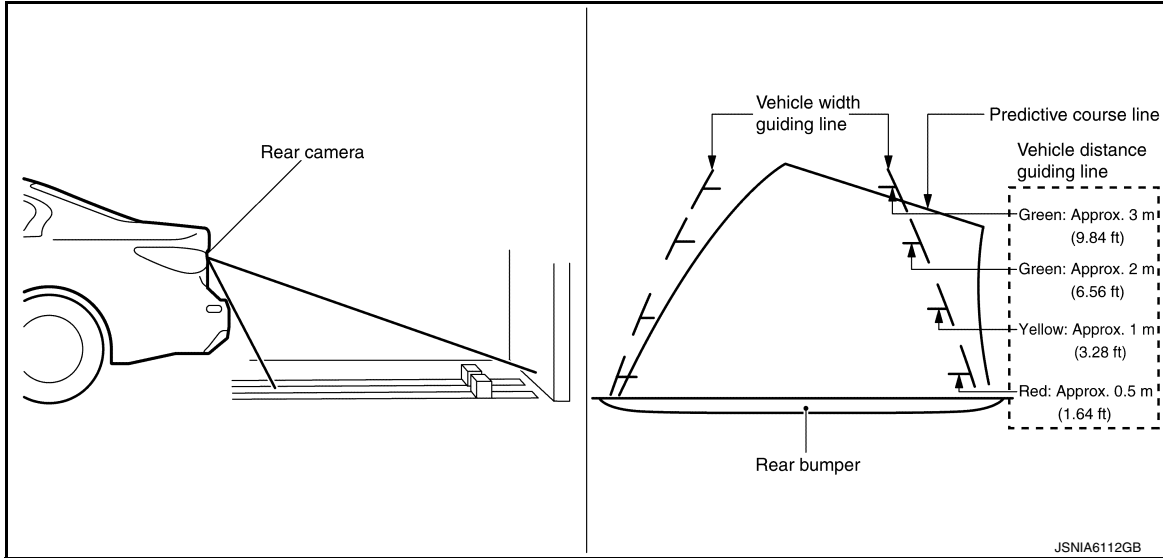

## Front-side View

- The front-side view image is from the side camera RH.
- In Front-Side view, display the vehicle distance guiding line and vehicle width guiding line.

Front-side view area and guiding line

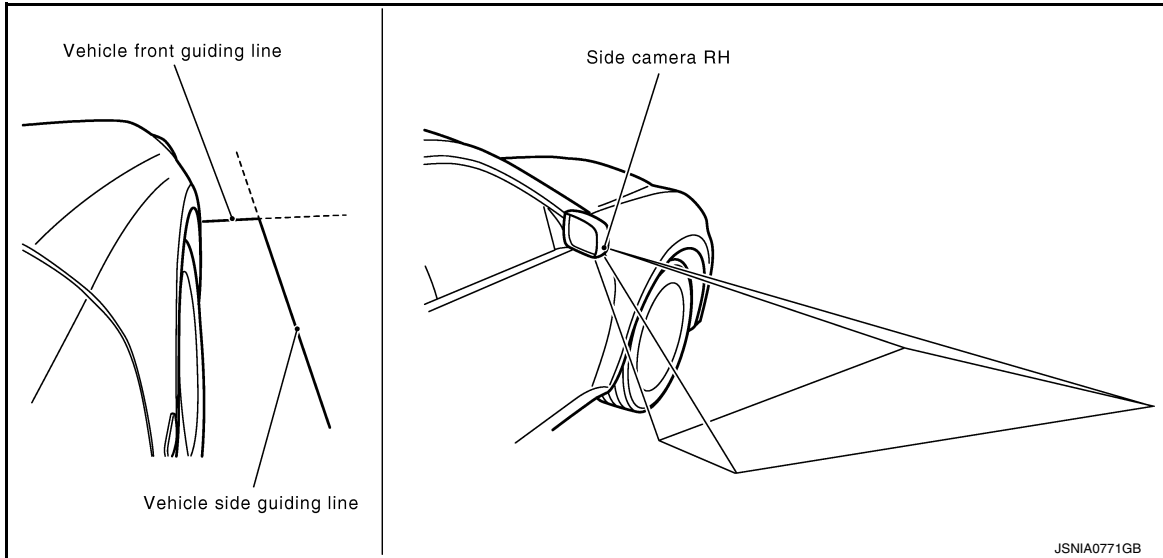

## Birds-eye View

- The image from the 4 cameras is cut out and converted into the overhead view, and the surroundings of the vehicle is displayed in birds-eye view.
- In Birds-Eye view, the invisible area is displayed on the image to specify the boundary of the 4 cameras.
- The invisible area is displayed in yellow in the Birds-Eye view after turning the ignition switch ON as an information for the user. (OFF setting can be performed)

# AROUND VIEW MONITOR SYSTEM

< SYSTEM DESCRIPTION >

[AROUND VIEW MONITOR SYSTEM]

Birds-Eye view display image

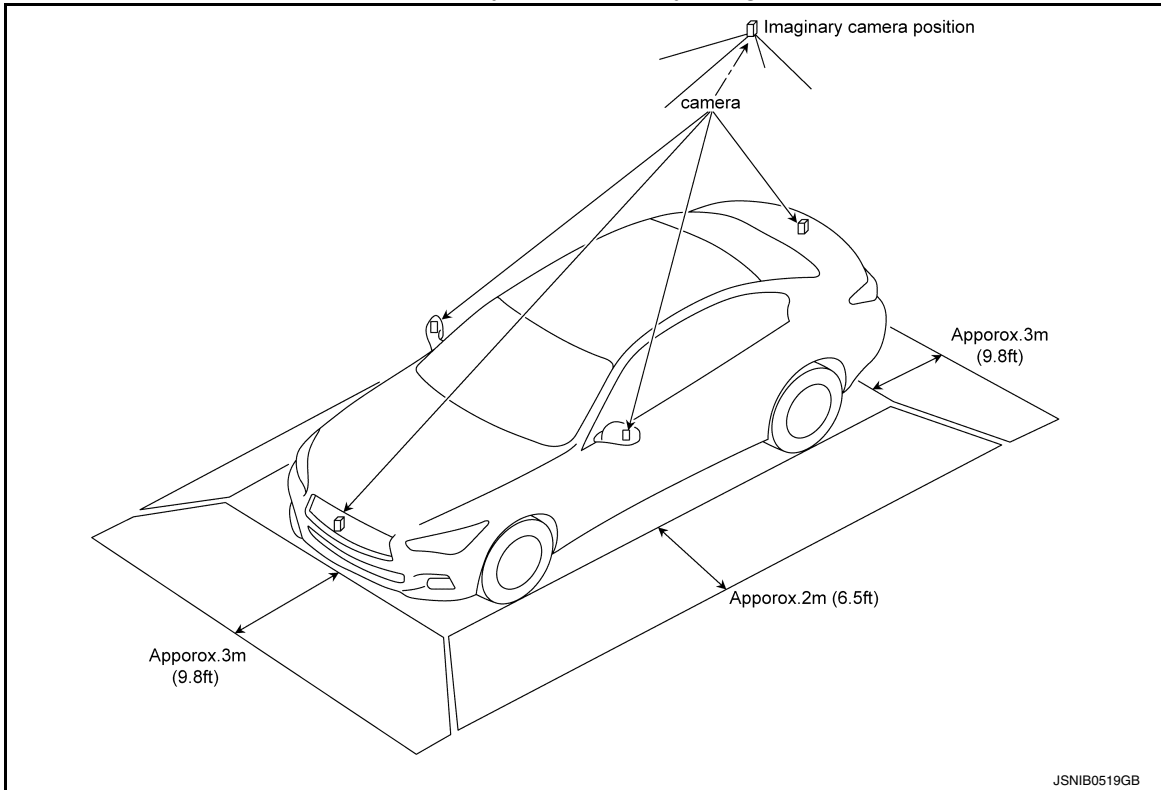

Birds-Eye view display area

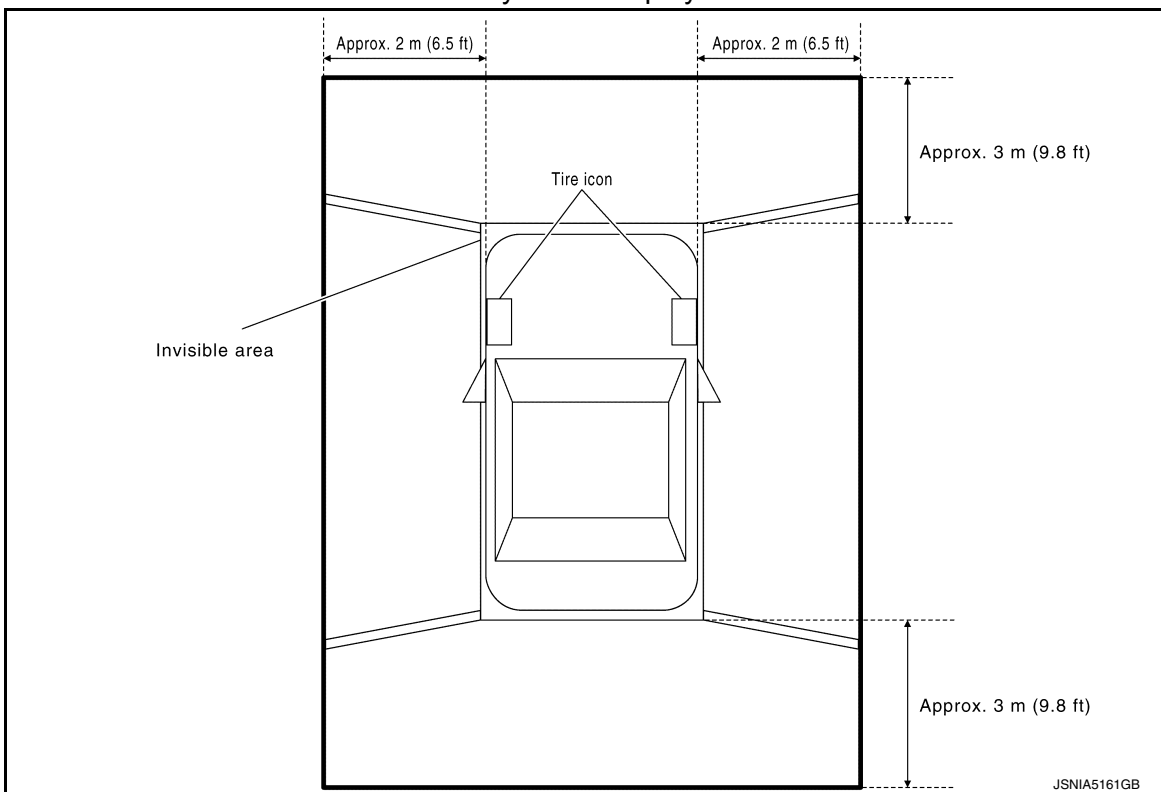

## Moving Object Detection (MOD)

- Moving Object Detection (MOD) is a function that notifies the driver of the presence of moving objects in the area around the vehicle. MOD detects moving objects from camera image, illuminates frame of view in yellow whenever "MOD" icon is displayed in blue, and sounds buzzer connected to sonar control unit.
- MOD detects moving objects while camera image is displayed on display control unit.
- Around view monitor control unit performs the following process when moving objects are detected.
  - Superimposes yellow frame line on camera image signal and outputs them to display control unit.

A  
B  
C  
D  
E  
F  
G  
H  
I  
J  
K  
L  
M  
O  
P

AV

# AROUND VIEW MONITOR SYSTEM

## < SYSTEM DESCRIPTION >

## [AROUND VIEW MONITOR SYSTEM]

- Transmits MOD beep sound output request signal to sonar control unit via CAN communication.
- Sonar control unit that receives the MOD beep sound output request signal from around view monitor control unit, and outputs buzzer drive signal to buzzer.
- Around view monitor control unit detects moving objects from camera image according to an image recognition method called optical flow.
- MOD does not detect a background as a moving object when the vehicle moves (when whole screen moves), but detects a moving object when an actual moving object is displayed on screen.
- MOD can be set to temporary OFF or permanent OFF by the following operation.
- temporary off: MOD is switched to off with a switch on the display control unit (touch switch) while camera image is displayed on display control unit.
- permanent off: MOD is switched to off by “Settings”.
- Color of “MOD” icon indicates whether or not MOD is operative. “MOD” icon is displayed as shown in the following table. when MOD is operative, “MOD” icon is displayed in blue. when MOD is not operative, “MOD” icon is displayed in gray. MOD icon is not displayed when MOD is off (permanent off) by “Settings”, or when MOD is off (temporary off) by switch of display control unit (touch switch).

View		Shift position		
		P or N position	D position	R position
		“MOD” icon display		
Birds-Eye view and rear view	Birds-Eye view	Blue	—	Gray
	Rear view	Gray		Blue
Birds-Eye view and front view	Birds-Eye view	Blue	Gray	—
	Front view	Gray	Blue	
Side view and rear view	Side view	×	—	×
	Rear view	Gray		Blue
Side view and front view	Side view	×	×	—
	Front view	Gray	Blue	
Front wide view		Gray	Blue	—

×: icon is not displayed.

—: view is not displayed in each shift position (D position and R position).

- MOD illuminates frame of view in yellow and sounds buzzer, when any of the conditions in the following table are satisfied.

Operation Condition		View where MOD is operative
Shift position	Vehicle speed	
P or N position	0 km/h	Birds-Eye view
D position	0 km/h (0 MPH) or more - less than 8 km/h (5 MPH)	<ul style="list-style-type: none"> <li>• Front view</li> <li>• Front wide view</li> </ul>
R position	0 km/h (0 MPH) or more - less than 8 km/h (5 MPH)	Rear view

- MOD does not operate or stops operation when any of the conditions in the following table are satisfied.

Operation stop condition	Note
Door open	<ul style="list-style-type: none"> <li>• MOD does not stop operation for front view and front wide view.</li> <li>• Operation stops for rear view while back door is open.</li> <li>• Operation stops for Birds-Eye view when any door is open.</li> </ul>
Door mirror expanding/retracting	Expanding/retracting status of door mirror is judged according to operation signal of door mirror motor transmitted from door mirror (driver side) to around view monitor control unit.

### Tire Icon

- Tire icon is adopted for Birds-Eye view screen.
- Tire icon is a function that notifies the steered direction of front tire to the driver and assists the driving.

# AROUND VIEW MONITOR SYSTEM

## [AROUND VIEW MONITOR SYSTEM]

### < SYSTEM DESCRIPTION >

- In tire icon, around view monitor control unit superimposes steering angle information to camera image and outputs camera image signal to display control unit.
- Around view monitor control unit judges steering angle according to steering signal received from steering angle sensor via CAN communication.

### CAMERA IMAGE OPERATION PRINCIPLE

- If the information writing to around view monitor control unit and the information from the camera are not matched, the applicable camera position is indicated as an error on the Birds-Eye view display. (Calibration operation is necessary when replacing each camera or when replacing around view monitor control unit.)
- Around view monitor control unit receives the camera switch signal from display control unit via AV communication by pressing the “CAMERA” switch of multifunction switch.
- Around view monitor control unit that receives the camera switch signal supplies the power to each camera and inputs the camera image from each camera.
- When the selector lever is in the reverse position, around view monitor control unit receives the reverse signal, supplies the power to each camera, and inputs the camera image from each camera.
- Around view monitor control unit that receives the camera image signal from each camera cuts out the required screen for each view, superimposes the camera image, vehicle icon, guiding lines, sonar indicator, “MOD” icon, and outputs them to the display unit.

### CAMERA ASSISTANCE SONAR FUNCTION

- Sonar sensors are installed on front bumper and rear bumper. When an obstacle is detected while around view monitor is displayed, a sonar indicator display and buzzer sound notify the driver of the proximity of an obstacle. When an obstacle is detected while around view monitor is not displayed, around view monitor screen is displayed automatically, and then notification is similarly as per the display and buzzer sound.
- Approaching distance between bumper and obstacle is displayed in 3 stages according to the color of the sonar indicator in display and blinking cycle of indicator.
- Warning by buzzer sound notifies distance to obstacle according to a 3-stage cycle.

### System Operation Description

- Sonar control unit receives shift position signal from TCM (VR30DDTT) or ECM (2.0L gasoline engine) and vehicle speed signal from ABS actuator control unit via CAN communication, and controls ON/OFF of sonar system.
- Sonar control unit transmits detection signal and detection distance signal to around view monitor via CAN communication, according to signal from corner sensor depending on conditions as shown in the following table. Around view monitor displays the applicable sonar indicator.

Sonar system operation condition			Sonar operation	
Shift position	Vehicle speed	Obstacle	Sonar indicator	Buzzer
R position	Less than 10 km/h (6 MPH)	Yes	Detection status is displayed	Yes
D position	Less than 10 km/h (6 MPH)	Yes	Detection status is displayed	Yes
P or N position	Less than 10 km/h (6 MPH)	Yes	Detection status is displayed*	None
—	10 km/h (6 MPH) or more	Yes	Not displayed	None

\*: Only when camera image is displayed.

- When sonar is OFF in “Settings”, sonar OFF display is displayed. Sonar OFF display is a function that displays frame in orange on the 4 corners of vehicle icon on Birds-Eye view to notify user of sonar OFF status. When sonar is switched to OFF by “Settings”, sonar OFF display is only displayed for rear side of vehicle icon
- Sonar control unit is equipped with diagnosis function. Corner sensor malfunction and sensor harness open circuit can be detected. Malfunction status is transmitted to around view monitor control unit. Sonar OFF status is displayed and notified to the user.

### Obstacle Detection Distance

- Sonar control unit switches output of sonar indicator and buzzer in 3 stages according to obstacle detection distance from corner sensor.
- Sonar control unit can change setting of obstacle detection distance in 3 stages.
- Sonar control unit can change setting of buzzer volume in 3 stages.

# AROUND VIEW MONITOR SYSTEM

< SYSTEM DESCRIPTION >

[AROUND VIEW MONITOR SYSTEM]

Obstacle detection image

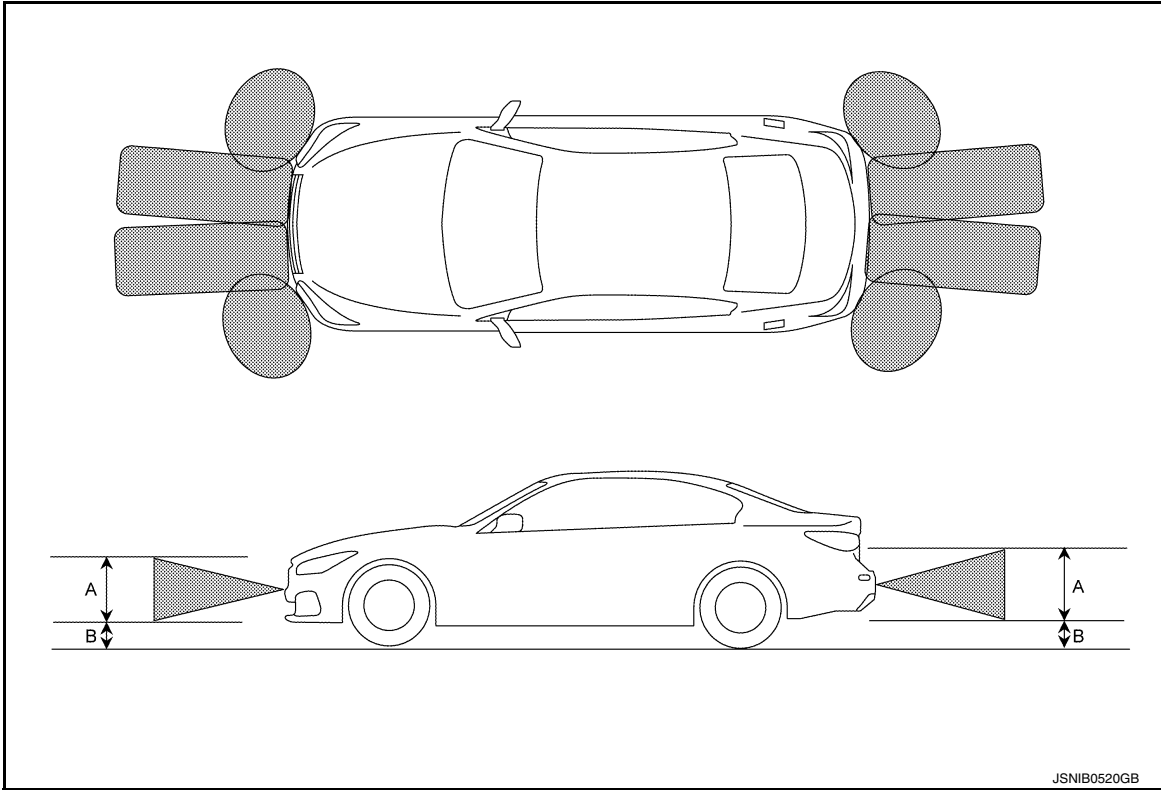

A. Approx. 50 cm (19.7 in)

B. Approx. 15 cm (5.9 in)

Detection distance (default value)

Warning item	Front corner sensor	Front center sensor	Rear corner sensor	Rear center sensor
First warning	—	60 – 100 cm (23.6 – 39.4 in)	—	60 – 150 cm (23.6 – 59.1 in)
Second warning	50 – 60 cm (19.7 – 23.6 in)	50 – 60 cm (19.7 – 23.6 in)	50 – 60 cm (19.7 – 23.6 in)	50 – 60 cm (19.7 – 23.6 in)
Third warning	40 – 50 cm (15.7 – 19.7 in)	40 – 50 cm (15.7 – 19.7 in)	40 – 50 cm (15.7 – 19.7 in)	40 – 50 cm (15.7 – 19.7 in)
Fourth warning	Less than 40 cm (15.7 in)	Less than 40 cm (15.7 in)	Less than 40 cm (15.7 in)	Less than 40 cm (15.7 in)

## Sonar Indicator Display

- When around view monitor control unit receives detection signal and detection distance signal from sonar control unit, the around view monitor control unit displays the sonar indicator on display control unit.
- Around view monitor control unit changes display color and indicator blinking cycle according to detection distance.

# AROUND VIEW MONITOR SYSTEM

< SYSTEM DESCRIPTION >

[AROUND VIEW MONITOR SYSTEM]

## Sonar indicator display color and blinking cycle

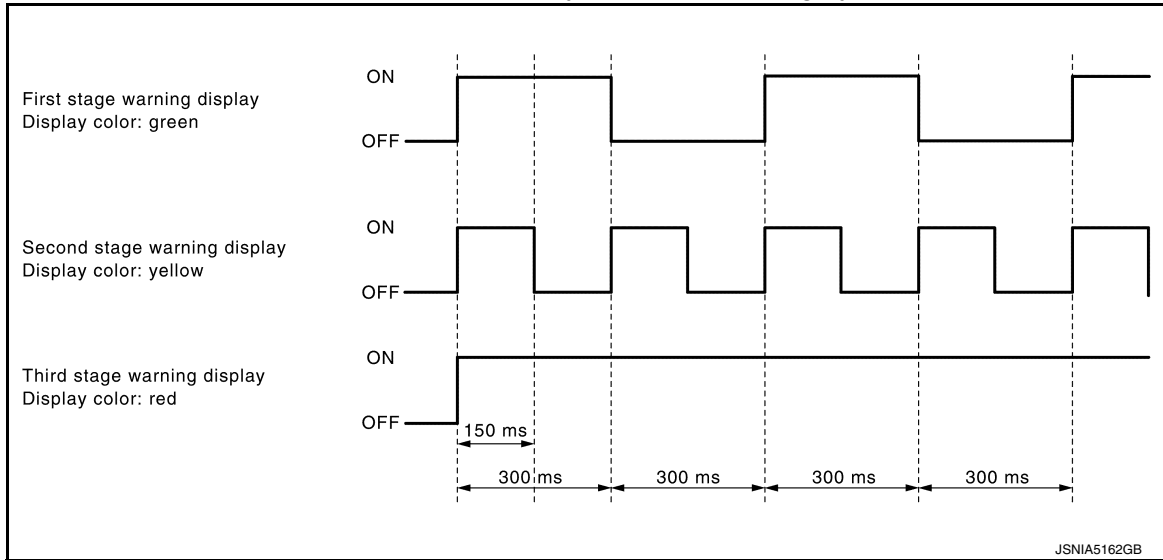

### Warning Buzzer Frequency

- The warning buzzer cycle changes between 4 levels (for front center and rear center) and 3 levels (for corner) according to the detection distance.
- The nearest sensor from the detected obstacle determines the buzzer cycle if plural sensors detect any obstacle simultaneously detected obstacles.
- If both the front and the rear sensor detect different objects simultaneously, the sensor which detects the closer object is prior to another sensor. If the detection distance is equal between the front and the rear, warning buzzer of rear sounds. (The front and the rear buzzers do not output the sounds simultaneously.)

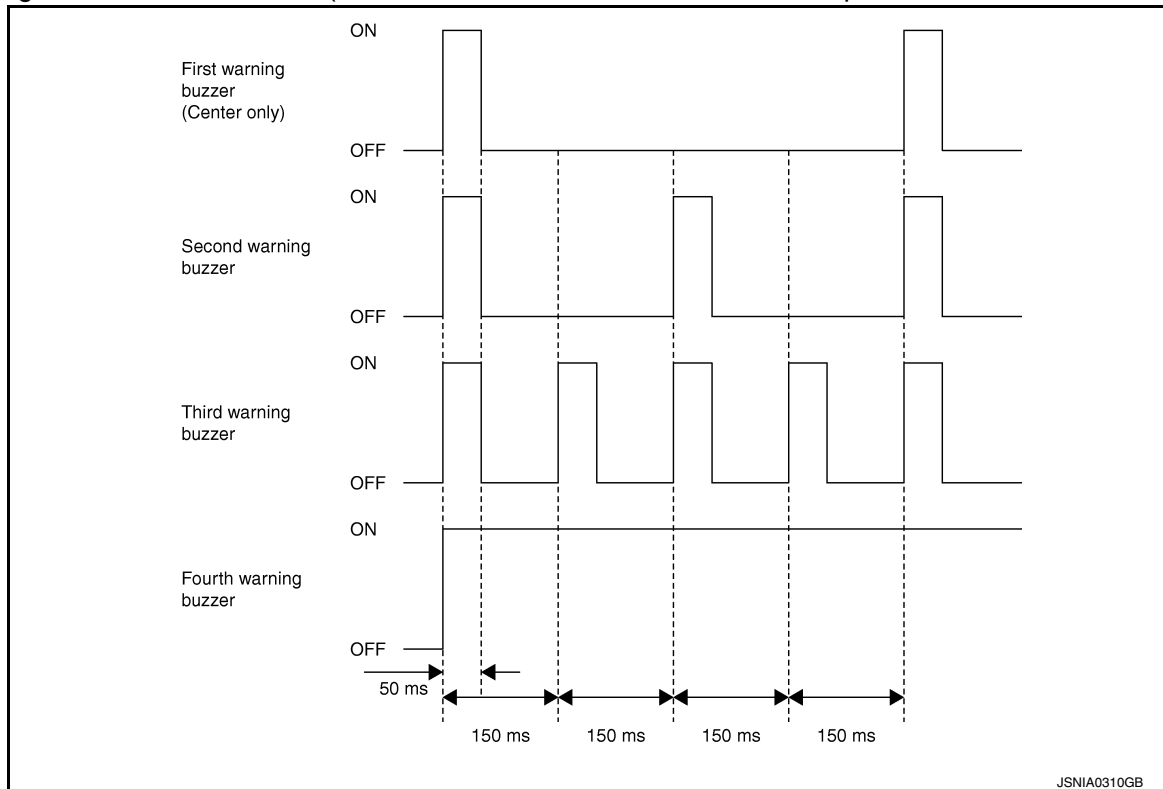

### NOTE:

The warning buzzer of the corner sensor sounds as follows:

- As for the first, second and third stages, the warning buzzer sound for 3 seconds at maximum.
- As for the fourth stage, the warning buzzer does not stop even after a lapse of 3 seconds.
- Buzzer stops when the vehicle moves away from an obstacle and the warning level decreases.

A  
B  
C  
D  
E  
F  
G  
H  
I  
J  
K  
L  
M  
AV  
O  
P

# AROUND VIEW MONITOR SYSTEM

## [AROUND VIEW MONITOR SYSTEM]

< SYSTEM DESCRIPTION >

### Circuit Diagram

INFOID:000000013717471

VR30DDTT

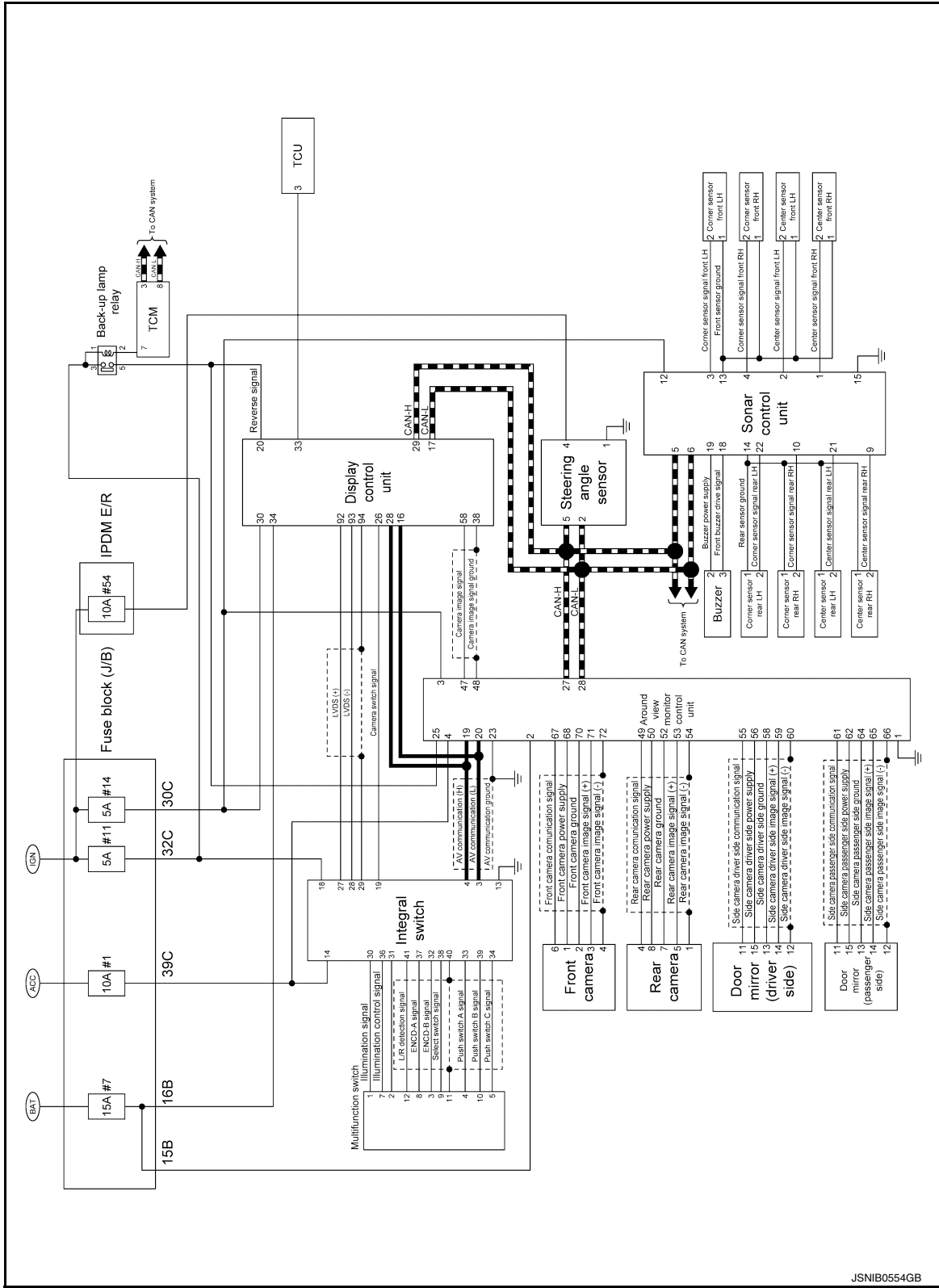

# AROUND VIEW MONITOR SYSTEM

< SYSTEM DESCRIPTION >

[AROUND VIEW MONITOR SYSTEM]

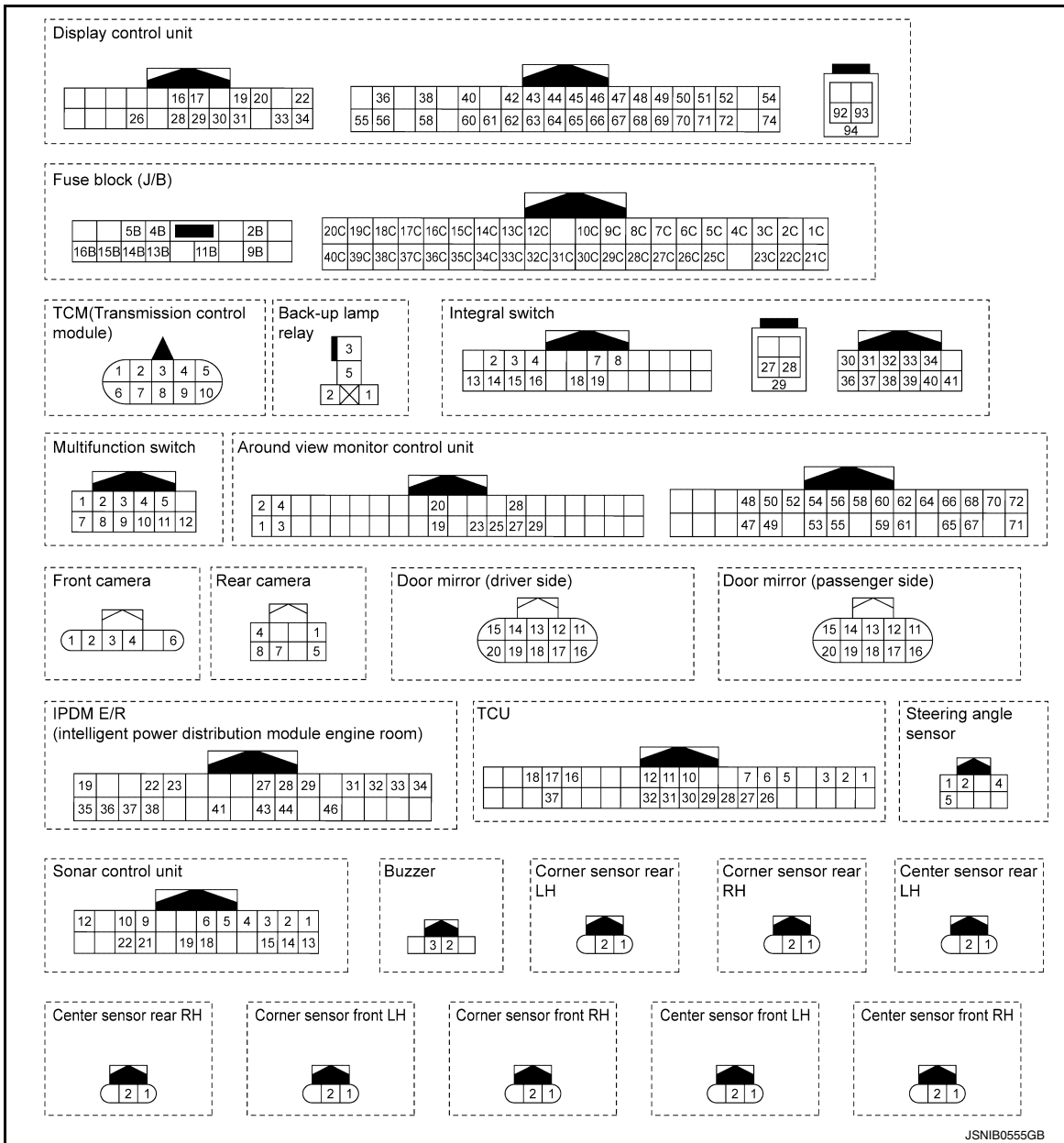

JSNIB0555GB

A  
B  
C  
D  
E  
F  
G  
H  
I  
J  
K  
L  
M  
AV  
O  
P

# AROUND VIEW MONITOR SYSTEM

< SYSTEM DESCRIPTION >

[AROUND VIEW MONITOR SYSTEM]

2.0L TURBO GASOLINE ENGINE

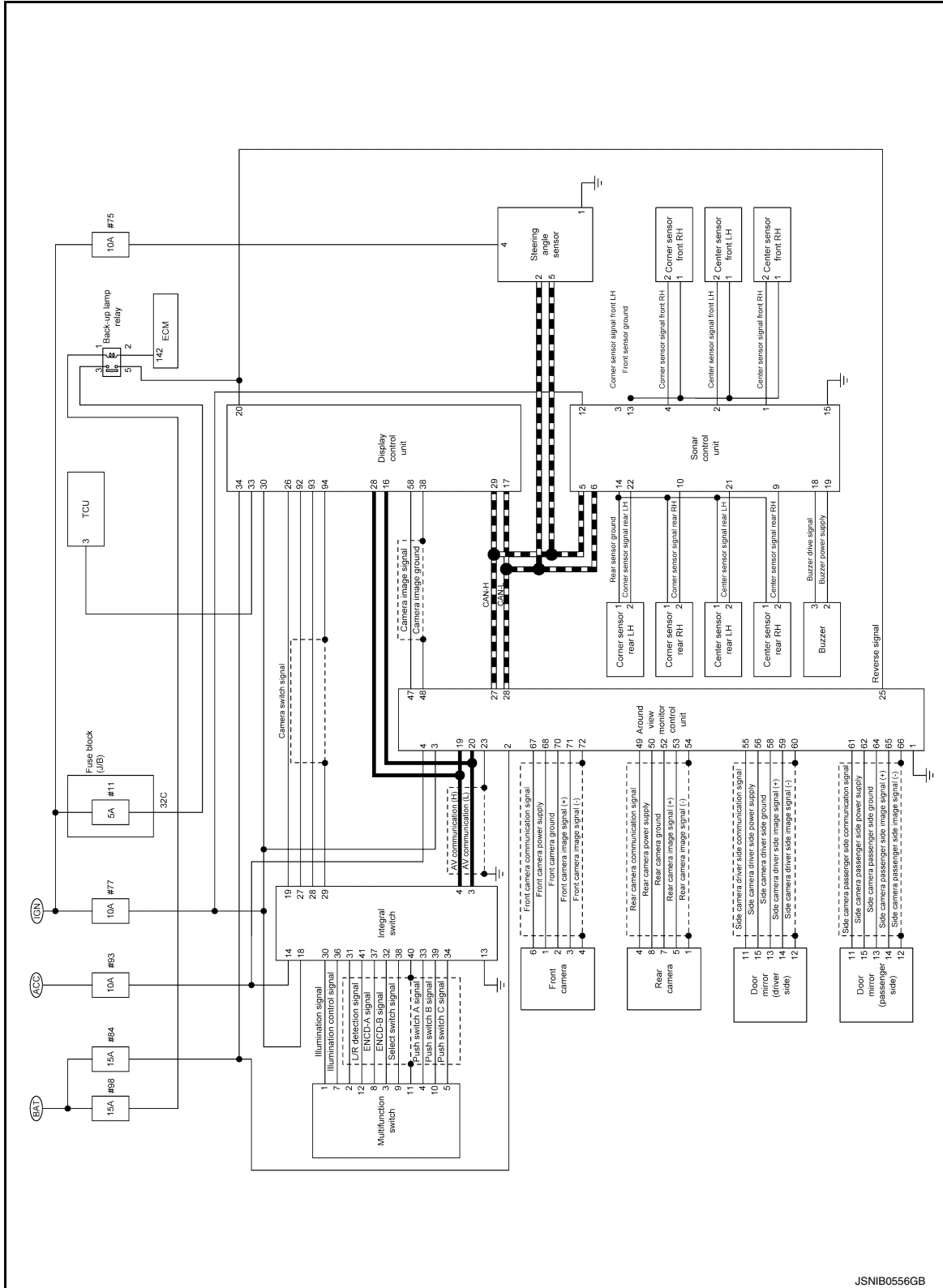

JSNIB0556GB

# AROUND VIEW MONITOR SYSTEM

< SYSTEM DESCRIPTION >

[AROUND VIEW MONITOR SYSTEM]

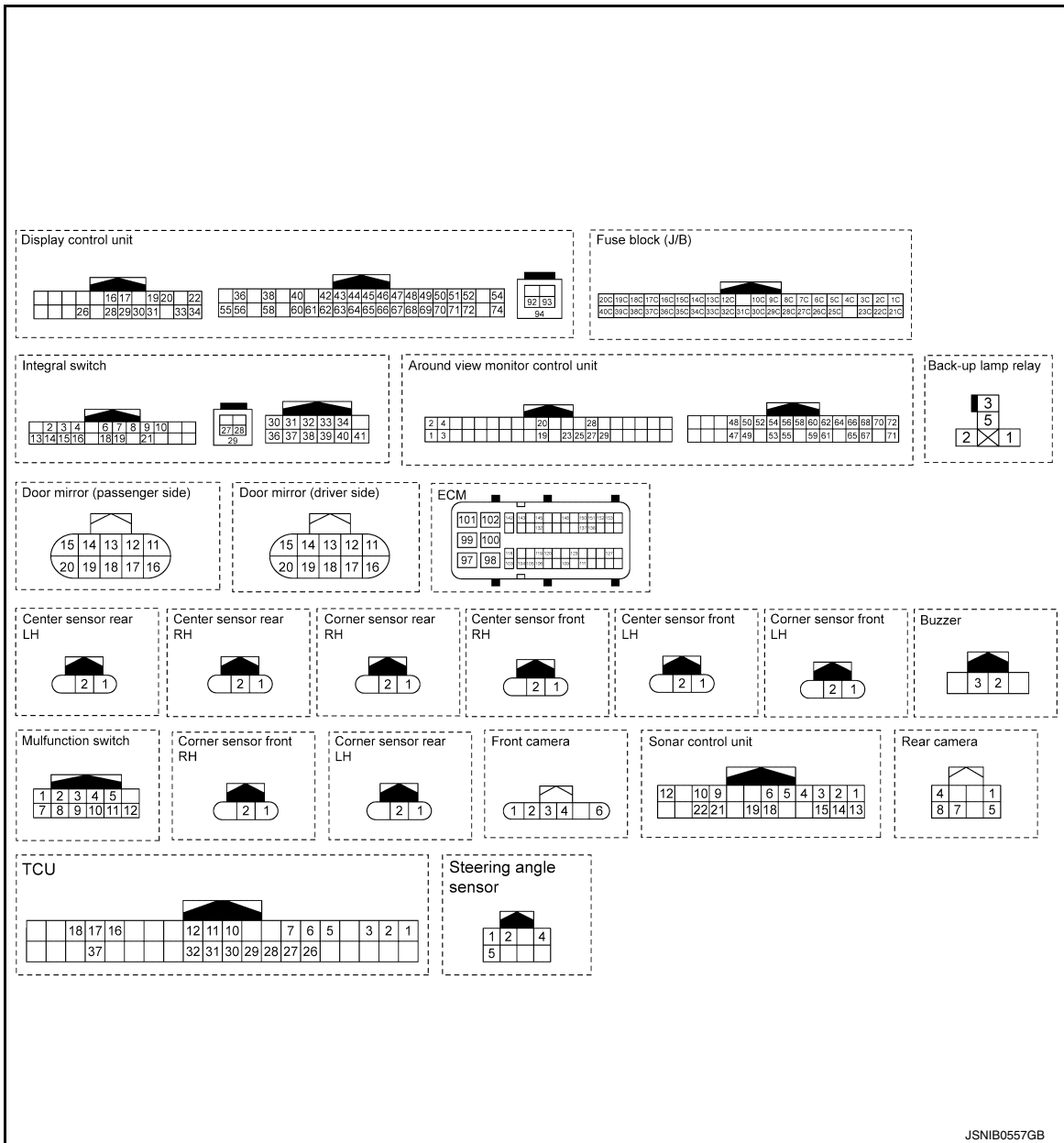

JSNIB0557GB

A  
B  
C  
D  
E  
F  
G  
H  
I  
J  
K  
L  
M

AV

# AROUND VIEW MONITOR SYSTEM

< SYSTEM DESCRIPTION >

[AROUND VIEW MONITOR SYSTEM]

## Fail-Safe (Around View Monitor Control Unit)

INFOID:000000013717472

DTC Display contents of CONSULT	Malfunction detection condition	Fail-safe condition
U0428: ST ANGLE SENSOR CALIBRATION	Neutral position adjustment of steering angle sensor is not complete.	<ul style="list-style-type: none"> <li>• Predicted course line is not displayed.</li> <li>• MOD (Moving Object Detection) function is stopped.</li> <li>• Front tire angle display is stopped.</li> <li>• Using "SETTING" menu display, switch each indicator of predicted course line display and MOD switch to "OFF" (turn OFF) so that switch operation cannot be performed.</li> </ul>
U1000: CAN COMM CIRCUIT	When around view monitor control unit cannot transmit/receive CAN communication signal continuously for 2 seconds or more.	<p>The following functions are stopped</p> <ul style="list-style-type: none"> <li>• When communication of steering angle sensor signal is not normal                             <ul style="list-style-type: none"> <li>- Predicted course line is not displayed.</li> <li>- MOD (Moving Object Detection) function is stopped.</li> <li>- Front tire angle display is stopped.</li> <li>- Using "SETTING" menu display, switch each indicator of predicted course line display and MOD switch to "OFF" (turn OFF) so that switch operation cannot be performed.</li> </ul> </li> <li>• When communication of vehicle signal, wheel speed sensor signal, and shift signal is not normal                             <ul style="list-style-type: none"> <li>- Predicted course line is not displayed.</li> <li>- MOD (Moving Object Detection) function is stopped.</li> <li>- Using "SETTING" menu display, switch each indicator of predicted course line display and MOD switch to "OFF" (turn OFF) so that switch operation cannot be performed</li> </ul> </li> <li>• When communication of sonar signal is not normal                             <ul style="list-style-type: none"> <li>- Predicted course line is not displayed.</li> </ul> </li> </ul>

# AROUND VIEW MONITOR SYSTEM

< SYSTEM DESCRIPTION >

[AROUND VIEW MONITOR SYSTEM]

DTC Display contents of CONSULT	Malfunction detection condition	Fail-safe condition
U111A: REAR CAMERA IMAGE SIGNAL	No-signal status of rear camera image signal is continued for 500 ms or more while ignition switch is ON. <b>NOTE:</b> Current malfunction is displayed only and is not saved.	Camera image is not displayed (Gray screen display).
U111B: SIDE CAMERA RH IMAGE SIGNAL	No-signal status of side camera RH image signal is continued for 500 ms or more while ignition switch is ON. <b>NOTE:</b> Current malfunction is displayed only and is not saved.	
U111C: FRONT CAMERA IMAGE SIGNAL	No-signal status of rear camera image signal is continued for 500 ms or more while ignition switch is ON. <b>NOTE:</b> Current malfunction is displayed only and is not saved.	
U111D: SIDE CAMERA LH IMAGE SIGNAL	No-signal status of side camera LH image signal is continued for 500 ms or more while ignition switch is ON. <b>NOTE:</b> Current malfunction is displayed only and is not saved.	
U1232: ST ANGLE SEN CALIB	Neutral position adjustment of steering angle sensor is performed. NG signal from steering angle sensor is received.	
U1302: CAMERA POWER VOLT	Camera power supply voltage does not satisfy the following conditions for 2 seconds or more when ignition switch is turned ON. <ul style="list-style-type: none"> <li>• When supplemental lighting power supply output is ON: 5.9 – 6.5 V.</li> <li>• When OFF: 0 V by camera power supply measurement.</li> </ul>	Camera power output is stopped.
U1304: CAMERA IMAGE CALIB	<ul style="list-style-type: none"> <li>• When camera calibration is incomplete.</li> <li>• When camera information in around view monitor control unit and information read from camera are not the same.</li> </ul> <b>NOTE:</b> Current malfunction is displayed only and is not saved.	Unmatched icon  display (red) is displayed (applicable for unmatched camera only).
U1305: CONFIG UNFINISH	The vehicle setting of around view monitor control unit is incomplete. <b>NOTE:</b> Current malfunction is displayed only and is not saved.	Operation is according to the vehicle setting value as default value.



A  
B  
C  
D  
E  
F  
G  
H  
I  
J  
K  
L  
M  
O  
P

AV

# AROUND VIEW MONITOR SYSTEM

< SYSTEM DESCRIPTION >

[AROUND VIEW MONITOR SYSTEM]

DTC Display contents of CONSULT	Malfunction detection condition	Fail-safe condition
Other	When around view monitor control unit is not normal.	Switch to camera screen is not allowed.
	When communication between around view monitor control unit and each camera is not normal.	On applicable camera screen  marking (Red) is displayed.
	When communication line between around view monitor control unit and each camera image line are affected by electromagnetic noises.	On applicable camera image screen,  display (Blue) is displayed.

## Fail-Safe (Sonar Control Unit)

INFOID:000000013717473

The warning buzzer function is deactivated when a sensor system error is detected.

## HANDLING PRECAUTION

### Display

INFOID:000000013717474

- When the compartment temperature is low, the display images may look slower because the LCD response is deteriorated. The system will recover its normal operation when the cabin temperature increases to an appropriate level.
- When the compartment temperature is low [0°C (32°F) or less], the display images may look slower. It is characteristic of the LCD monitor and should not be considered to be a malfunction. When the temperature is at the operating temperature [0°C (32°F) to 50°C (122°F)], the display returns to normal.
- There may be small dark or bright dots in the screen or remaining display content may be found (image lag). These are inherent symptoms to any LCD monitor and should not be considered to be a malfunction.
- The image may look bright or dark when viewed obliquely from the rear. It is inherent to any LCD monitor and should not be considered to be a malfunction.
- Do not apply pressure on the LCD monitor. Doing so may cause irregularities in the screen image or render it inoperative.
- Do not use hard cloth, organic solvent (alcohol, benzene, and thinner), or chemical wipe to clean the LCD monitor. Doing so may affect the panel surface. When cleaning the LCD monitor, always wipe it with a soft cloth after shutting off the power. For severe contamination, use a soft cloth dampened with mild detergent (no droplets can be present).

### Around View Monitor

INFOID:000000013717475

#### PRECAUTIONS FOR THE HANDLING OF CAMERA SYSTEM

- The camera system assists the detection of obstacles. When operating the vehicle, the safety must be confirmed and ensured directly by sight, using the mirrors.
- Distance shown by vehicle width guiding lines and predicted course lines may differ from actual distance depending on the number of passengers and fuel capacity. For this reason, these lines must be used only as a guide.
- With the camera lens characteristics, a distance shown on the screen may look different from actual distance or obstacles may look deformed.
- The camera is a precision instrument. Always prevent a strong impact, such as high-pressure car wash. Failure to do this results in a malfunction.
- Adhesion of dirt, rain drops, and snow to the camera lens may lower the sharpness of camera image or cause an improper operation in MOD (Moving Object Detection) function or parking frame recognition function. These adherents must be removed with a soft wet cloth first, then with a dry soft cloth.
- Never damage the camera. Failure to do this may affect camera images.

#### PRECAUTIONS FOR THE HANDLING OF MOD (MOVING OBJECT DETECTION)

- MOD (Moving Object Detection) does not inform the driver of stationary objects.
- MOD (Moving Object Detection) detects a moving object by processing image data of an image shown on the display. The detection performance of a moving object is limited.
- MOD (Moving Object Detection) may not operate properly when any of the following conditions is satisfied:
  - Color and brightness of a moving object are similar to those of its background.
  - Existence of blinking light, such as turn signal lamp
  - Reflection of a strong light, such as head lamp light from other vehicles or sun light.
  - Inappropriate orientation of camera due to folded mirror.
  - Non-moving objects, such as water droplets dripping on the camera lens, white smoke from the muffler or moving shadow may be detected.
  - Detection may not be performed properly depending on the speed, direction, distance, and shape of moving object.

#### PRECAUTIONS FOR THE HANDLING OF SONAR SYSTEM

- Ultrasonic sensors detect an obstacle by using strong reflected waves (echo) reflected from the obstacle. For this reason, an obstacle may not be detected properly if any of the following item applies:
  - Soft and air-containing object, such as cloth, cotton, glass wool, dust, and snow.
  - Slanted slick object.
  - Angle of an angular object.
  - Thin object, such as rope, chain, and wire
  - Fast-moving small animal
- The detection may be unstable due to irregular reflection when any of the following conditions is satisfied:
  - Object with rough surface, such as rock, stone, and gravel.

A  
B  
C  
D  
E  
F  
G  
H  
I  
J  
K  
L  
M  
O  
P

AV

## HANDLING PRECAUTION

< SYSTEM DESCRIPTION >

[AROUND VIEW MONITOR SYSTEM]

---

- Close to an object emitting sonic waves or electromagnetic waves.
- The surface of sensor is frozen, snow-covered, dirty, or wet.
- Extremely close to an obstacle [Approximately 20 cm (7.87 in) or less is the physical limit of obstacle detection by supersonic waves.]
- Under severe weather conditions, such as heavy snow, heavy rain, and strong wind.
- The vehicle is left stand under the hot sun or in a cold climate area for a long time.

# DIAGNOSIS SYSTEM (AROUND VIEW MONITOR CONTROL UNIT)

< SYSTEM DESCRIPTION >

[AROUND VIEW MONITOR SYSTEM]

## DIAGNOSIS SYSTEM (AROUND VIEW MONITOR CONTROL UNIT)

### CONSULT Function

INFOID:000000013717476

### CONSULT FUNCTIONS

CONSULT performs the following functions via the communication with the around view monitor control unit.

Diagnosis mode	Description
Self Diagnostic Result	Around view monitor control unit and AV communication circuit connection diagnosis is performed. Current and previous malfunctions are displayed collectively.
Data Monitor	Diagnosis of vehicle signal that is received by around view monitor control unit can be performed.
Work support	<ul style="list-style-type: none"><li>• Calibration and initialization of each camera can be performed.</li><li>• Fine tuning of Birds-Eye view can be performed.</li><li>• Target line calibration of front wide view can be performed.</li><li>• Display of predicted course line can be switched to ON/OFF.</li><li>• Language of warning message can be selected.</li><li>• Neutral position adjustment of steering angle sensor can be performed.</li><li>• Camera screen activation enhancing display can be switched to ON/OFF.</li><li>• Calibration of turning radius display can be performed.</li><li>• Setting change can be performed depending on the vehicle specification with/without door mirror automatic retracting function.</li><li>• "SONAR OFF" display can be switched to ON/OFF.</li><li>• Camera zoom ratio can be changed and used for fine tuning.</li></ul>
ECU Identification	Around view monitor control unit part number, software version, and hardware version can be identified.
Configuration	<ul style="list-style-type: none"><li>• The vehicle specification that is written in around view monitor control unit can be displayed or stored.</li><li>• The vehicle specification can be written when around view monitor control unit is replaced.</li></ul>

### SELF DIAGNOSTIC RESULT

Refer to [AV-512. "DTC Index"](#).

- In CONSULT self-diagnosis, self-diagnosis results and error history are displayed collectively.
- The current malfunction indicates "CRNT". The past malfunction indicates "PAST".

### Freeze Frame Data (FFD)

The following vehicle status is recorded when DTC is detected and is displayed on CONSULT.

Item name	Display content
IGN COUNTER (0 to 39)	<p>Numerical value is displayed indicating the number of times that ignition switch is turned ON after the DTC is detected.</p> <ul style="list-style-type: none"><li>• When "0" is displayed, it indicates that the system is presently malfunctioning.</li><li>• When any numerical number other than "0" is displayed, it indicates that system malfunction in the past is detected, but the system is presently normal.</li></ul> <p><b>NOTE:</b> Each time when ignition switch turns OFF→ON, numerical number increases from 1→2→3...38→39. When number of times exceeds 39, numeric display does not increase and 39 is displayed until self-diagnosis is erased.</p>

### DATA MONITOR

#### NOTE:

The following table includes information (items) inapplicable to this vehicle. For information (items) applicable to this vehicle, refer to CONSULT display items.

- Displays the status of the following vehicle signals inputted into the around view monitor control unit.
- For each signal, actual signal can be compared with the condition recognized on the system.

# DIAGNOSIS SYSTEM (AROUND VIEW MONITOR CONTROL UNIT)

< SYSTEM DESCRIPTION >

[AROUND VIEW MONITOR SYSTEM]

Display Item	Remarks
ST ANGLE SENSOR SIGNAL [On/Off]	Receiving status of steering angle signal received from steering angle sensor is switched to ON/OFF.
REVERSE SIGNAL [On/Off]	Receiving status of reverse signal received from display control unit is displayed by ON/OFF.
VEHICLE SPEED SIGNAL [On/Off]	Receiving status of vehicle speed signal received from ABS actuator control unit is displayed by ON/OFF.
CAMERA SWITCH SIGNAL [On/Off]	Receiving status of camera switch signal received from display control unit is displayed by ON/OFF.
CAMERA OFF SIGNAL [On/Off]	Receiving status of camera OFF signal received from display control unit is displayed by ON/OFF.
ST ANGLE SENSOR TYPE [Absolute]	Input type of steering angle sensor is displayed. <b>NOTE:</b> For this vehicle, "Absolute" is displayed.
STEERING GEAR RATIO TYPE [TYPE1]	Type of steering gear ratio is displayed. <b>NOTE:</b> For this vehicle, "TYPE 1" is displayed.
STEERING POSITION [LHD/RHD]	Steering position is displayed.
REAR CAMERA IMAGE SIGNAL [OK/NG]	Input status of rear view camera image signal is displayed by OK/NG in real time.
R-CAMERA COMM STATUS [OK/NG]	Communication status with rear camera is displayed by OK/NG in real time.
R-CAMERA COMM LINE [OK/NG]	Status of communication line with rear camera is displayed by OK/NG in real time.
F-CAMERA IMAGE SIGNAL [OK/NG]	Input status of front view camera image signal is displayed by OK/NG in real time.
F-CAMERA COMM STATUS [OK/NG]	Communication status with front camera is displayed by OK/NG in real time.
F-CAMERA COMM LINE [OK/NG]	Status of communication line with front camera is displayed by OK/NG in real time.
DR-SIDE CAMERA IMAGE SIG [OK/NG]	Input status of side camera LH image signal is displayed by OK/NG in real time.
DR CAMERA COMM STATUS [OK/NG]	Communication status with side camera LH is displayed by OK/NG in real time.
DR-SIDE CAMERA COMM LINE [OK/NG]	Status of communication line with side camera LH is displayed by OK/NG in real time.
PA-SIDE CAMERA IMAGE SIG [OK/NG]	Input status of side camera RH image signal is displayed by OK/NG in real time.
PA CAMERA COMM STATUS [OK/NG]	Communication status with side camera RH is displayed by OK/NG in real time.
PA-SIDE CAMERA COMM LINE [OK/NG]	Status of communication line with side camera RH is displayed by OK/NG in real time.
ACC [OK/NG]	Input status of ACC signal input to around view monitor control unit is displayed by ON/OFF in real time.
FOLDING MOTOR VOLT 1 [ON/OFF]	Input status of retractable power door mirror LH operation signal input to around view monitor control unit is displayed by ON/OFF in real time.
FOLDING MOTOR VOLT 2 [ON/OFF]	Input status of retractable power door mirror LH operation signal input to around view monitor control unit is displayed by ON/OFF in real time.

## WORK SUPPORT

# DIAGNOSIS SYSTEM (AROUND VIEW MONITOR CONTROL UNIT)

< SYSTEM DESCRIPTION >

[AROUND VIEW MONITOR SYSTEM]

Work support items	Description	
NON-VIEWABLE AREA REMINDER	ON/OFF setting of the non-viewable area reminder can be performed.	A
INITIALIZE CAMERA IMAGE CALIBRATION	The calibration can be initialized to factory shipment condition. <b>NOTE:</b> Calibration of camera image caused by misalignment of the camera installation position is performed.	B
STEERING ANGLE SENSOR ADJUSTMENT	Steering angle sensor neutral position can be adjusted and registered. <b>CAUTION:</b> For vehicles with VDC, adjust the steering angle sensor neutral position on the ABS actuator control unit side. Refer to <a href="#">BRC-92, "Description"</a> .	C
CALIBRATING CAMERA IMAGE (FRONT CAMERA)	Performs the calibration of front camera. <b>NOTE:</b> Calibration of camera image caused by misalignment of the camera installation position is performed.	D
CALIBRATING CAMERA IMAGE (PASS-SIDE CAMERA)	Performs the calibration of side camera RH. <b>NOTE:</b> Calibration of camera image caused by misalignment of the camera installation position is performed.	E
CALIBRATING CAMERA IMAGE (DR-SIDE CAMERA)	Performs the calibration of side camera LH. <b>NOTE:</b> Calibration of camera image caused by misalignment of the camera installation position is performed.	F
CALIBRATING CAMERA IMAGE (REAR CAMERA)	Performs the calibration of rear camera. <b>NOTE:</b> Calibration of camera image caused by misalignment of the camera installation position is performed.	G
FINE TUNING OF BIRDS-EYE VIEW	The confirmation and adjustment of the difference between each camera can be performed. The fine adjustment function of camera calibration can check and adjust the difference between each camera.	H
TURNING RADIUS CORRECTION	Corrects the length of the turning radius used for parking guidance. <b>NOTE:</b> Not used under normal conditions.	I
PARTS WITH DOOR MIRROR AUTO FOLD FUNC	Item is displayed, but it is not used.	J
SONAR Off POP-UP DISPLAY SETTING CHANGE	"SONAR OFF" display can be switched to ON/OFF.	K
FRONT WIDE-VIEW FIXED GUIDE LINE CORRECTION	The position of front wide view guiding line can be changed.	L
ZOOM FUNCTION	Zoom ratio of each camera can be changed. <b>NOTE:</b> When the position cannot be aligned using "FINE TUNING OF BIRDS-EYE VIEW", the adjustment may be performed using this "ZOOM FUNCTION".	M

A  
B  
C  
D  
E  
F  
G  
H  
I  
J  
K  
L  
M  
AV

## ECU IDENTIFICATION

Around view monitor control unit part number, software version, and hardware version can be identified.

## CONFIGURATION

Configuration includes functions as follows.

Function	Description
Read/Write Configuration	Before Replace ECU Allows the reading of vehicle specification written in around view monitor control unit to store the specification in CONSULT.
	After Replace ECU Allows the writing of the vehicle information stored in CONSULT into the around view monitor control unit.
Manual Configuration	Allows the writing of the vehicle specification into the around view monitor control unit by hand.

O  
P

## DIAGNOSIS SYSTEM (AROUND VIEW MONITOR CONTROL UNIT)

< SYSTEM DESCRIPTION >

[AROUND VIEW MONITOR SYSTEM]

---

### **CAUTION:**

- When replacing around view monitor control unit, you must perform “Read / Write Configuration” or “Manual Configuration” with CONSULT.
- Complete the procedure of “Read / Write Configuration” or “Manual Configuration” in order.
- If you set incorrect “Read / Write Configuration” or “Manual Configuration”, incidents might occur.
- Configuration is different for each vehicle model. Confirm configuration of each vehicle model.
- Never perform “Read / Write Configuration” or “Manual Configuration” except for new around view monitor control unit.

# DIAGNOSIS SYSTEM (SONAR CONTROL UNIT)

< SYSTEM DESCRIPTION >

[AROUND VIEW MONITOR SYSTEM]

## DIAGNOSIS SYSTEM (SONAR CONTROL UNIT)

### CONSULT Function

INFOID:000000013717477

### CONSULT FUNCTIONS

CONSULT performs the following functions via communication with sonar control unit.

Diagnosis mode	Description
Self Diagnostic Result	The malfunctions recorded in the memory of sonar control unit are displayed.
Data Monitor	Sonar control unit input/output signal data is displayed in real time.
Work support	Performs volume adjustment of sonar buzzer.
Active Test	Performs operation check of sonar buzzer.
Ecu Identification	Displays the sonar control unit part number.
Configuration	<ul style="list-style-type: none"><li>The vehicle specification that is written in sonar control unit can be displayed and stored.</li><li>The vehicle specification can be written when sonar control unit is replaced.</li></ul>

### SELF DIAGNOSTIC RESULT

Refer to [AV-518, "DTC Index"](#).

#### Freeze Frame Data (FFD)

The following vehicle status is recorded when DTC is detected and is displayed on CONSULT.

Item name	Display content
ODO/TRIP METER (km)	Total driving distance (odometer value) upon DTC detection is displayed.

### DATA MONITOR

#### NOTE:

The following table includes information (items) inapplicable to this vehicle. For information (items) applicable to this vehicle, refer to CONSULT display items.

Monitor item	Description
VEHICLE SPEED [km/h]	Vehicle speed that is calculated by vehicle speed signal received from the ABS actuator control unit is displayed.
SONAR C/U POWER SUPPLY [V]	Ignition power supply voltage received by sonar control unit is displayed.
SENSOR VOLTAGE [V]	Drive voltage transmitted to each corner sensor is displayed.
DETECTION MODE [Mode 1/Mode 2]	Indicates condition of display detection mode.
SW OPRT AFTR IGN ON [Yes/No]	Indicates condition of switch operation after ignition ON signal.
SONAR TEMPORARY OFF [Yes/No]	Indicates condition of sonar system.
SONAR PERMANENT OFF [Yes/No]	Indicates condition of sonar system.
P N RANGE [On/Off]	Status of P or N position received from TCM is displayed.
LED [On/Off]	Indicates condition of LED.
TRAILER CONNECT [N CON/CON]	Indicates condition of trailer connector.
REVERSE RANGE [On/Off]	Status of R position received from TCM is displayed.

# DIAGNOSIS SYSTEM (SONAR CONTROL UNIT)

< SYSTEM DESCRIPTION >

[AROUND VIEW MONITOR SYSTEM]

Monitor item	Description
SHRT DST FRM RR SENS	Display the closest distance detected by the rear sensor.
SHRT DST FRM FR SENS	Display the closest distance detected by the front sensor.
COR[RL]	Distance according to oscillation from corner sensor rear LH and detection by corner sensor rear LH.
COR[RL]->CEN[RL]/CEN[R]	Distance according to oscillation from corner sensor rear LH and detection by center sensor rear LH.
CEN[RL]/CEN[R]->COR[RL]	Distance according to oscillation from center sensor rear LH and detection by corner sensor rear LH.
CEN[RL]/CEN[R]	Distance according to oscillation from center sensor rear LH and detection by center sensor rear LH.
CEN[RL]->CEN[RR]	Distance according to oscillation from center sensor rear LH and detection by center sensor rear RH.
CEN[RR]->CEN[RL]	Distance according to oscillation from center sensor rear RH and detection by center sensor rear LH.
CEN[RR]	Distance according to oscillation from center sensor rear RH and detection by center sensor rear RH.
CEN[RR]/CEN[R]->COR[RR]	Distance according to oscillation from center sensor rear RH and detection by corner sensor rear RH.
COR[RR]->CEN[RR]/CEN[R]	Distance according to oscillation from corner sensor rear RH and detection by center sensor rear RH.
COR[RR]	Distance according to oscillation from rear corner sensor RH and detection by rear corner sensor RH.
COR[FL]	Distance according to oscillation from front corner sensor LH and detection by front corner sensor LH.
COR[FL]->CEN[FL]/CEN[F]	Distance according to oscillation from corner sensor front LH and detection by center sensor front LH.
CEN[FL]/CEN[F]->COR[FL]	Distance according to oscillation from center sensor front LH and detection by corner sensor front LH.
CEN[FL]/CEN[F]	Distance according to oscillation from center sensor front LH and detection by center sensor front LH.
CEN[FL]->CEN[FR]	Distance according to oscillation from center sensor front LH and detection by center sensor front RH.
CEN[FR]->CEN[FL]	Distance according to oscillation from center sensor front RH and detection by center sensor front LH.
CEN[FR]	Distance according to oscillation from center sensor front RH and detection by center sensor front RH.
CEN[FR]/CEN[F]->COR[FR]	Distance according to oscillation from center sensor front RH and detection by corner sensor front RH.
COR[FR]->CEN[FR]/CEN[F]	Distance according to oscillation from corner sensor front RH and detection by center sensor front RH.
COR[FR]	Distance according to oscillation from corner sensor front RH and detection by front corner sensor RH.
RVRB TIME COR[RL]	Reverberating time of corner sensor rear LH. <b>NOTE:</b> Reverberating time is a period of time while sensor vibrates by super sonic waves after oscillating super sonic waves.
RVRB TIME COR[RR]	Reverberating time of corner sensor rear RH. <b>NOTE:</b> Reverberating time is a period of time while sensor vibrates by super sonic waves after oscillating super sonic waves.
RVRB TIME CEN[RL]	Reverberating time of center sensor rear LH. <b>NOTE:</b> Reverberating time is a period of time while sensor vibrates by super sonic waves after oscillating super sonic waves.
RVRB TIME CEN[RR]	Reverberating time of center sensor rear RH. <b>NOTE:</b> Reverberating time is a period of time while sensor vibrates by super sonic waves after oscillating super sonic waves.

# DIAGNOSIS SYSTEM (SONAR CONTROL UNIT)

[AROUND VIEW MONITOR SYSTEM]

< SYSTEM DESCRIPTION >

Monitor item	Description
RVRB TIME COR[FL]	Reverberating time of corner sensor front LH. <b>NOTE:</b> Reverberating time is a period of time while sensor vibrates by super sonic waves after oscillating super sonic waves.
RVRB TIME COR[FR]	Reverberating time of corner sensor front RH. <b>NOTE:</b> Reverberating time is a period of time while sensor vibrates by super sonic waves after oscillating super sonic waves.
RVRB TIME CEN[FL]	Reverberating time of center sensor front LH. <b>NOTE:</b> Reverberating time is a period of time while sensor vibrates by super sonic waves after oscillating super sonic waves.
RVRB TIME CEN[FR]	Reverberating time of center sensor front RH. <b>NOTE:</b> Reverberating time is a period of time while sensor vibrates by super sonic waves after oscillating super sonic waves.

## WORK SUPPORT

Work support items	Description
VOLUME SETTING	Volume of sonar buzzer can be adjusted in 3 stages.
TRAILER HITCH DETECTION RANGE ADJUSTMENT	Allows to adjust rear sonar sensors for trailer towing.

## ACTIVE TEST

Test item	Function
FRONT BUZZER	Sonar buzzer (front) can be operated.

## ECU IDENTIFICATION INFORMATION

Displays sonar control unit part number.

## CONFIGURATION

Configuration includes functions as follows.

Function	Description	
Read/Write Configuration	Before Replace ECU	Allows the reading of vehicle specification written in sonar control unit to store the specification in CONSULT.
	After Replace ECU	Allows the writing of the vehicle information stored in CONSULT into the sonar control unit.
Manual Configuration	Allows the writing of the vehicle specification into the sonar control unit by hand.	

### CAUTION:

- When replacing sonar control unit, you must perform “Read / Write Configuration” or “Manual Configuration” with CONSULT.
- Complete the procedure of “Read / Write Configuration” or “Manual Configuration” in order.
- If you set incorrect “Read / Write Configuration” or “Manual Configuration”, incidents might occur.
- Configuration is different for each vehicle model. Confirm configuration of each vehicle model.
- Never perform “Read / Write Configuration” or “Manual Configuration” except for new sonar control unit.

# DISPLAY CONTROL UNIT

< ECU DIAGNOSIS INFORMATION >

[AROUND VIEW MONITOR SYSTEM]

## ECU DIAGNOSIS INFORMATION

### DISPLAY CONTROL UNIT

#### Reference Value

INFOID:000000013974238

#### VALUES ON THE DIAGNOSIS TOOL

##### NOTE:

The following table includes information (items) inapplicable to this vehicle. for information (items) applicable to this vehicle, refer to CONSULT display items.

Monitor Item	Condition		Value/Status
VHCL SPD SIG	Ignition switch ON	Vehicle speed > 0 km/h (0 MPH)	On
		Vehicle speed = 0 km/h (0 MPH)	Off
PKB SIG	Ignition switch ON	Parking brake is applied.	On
		Parking brake is released.	Off
ILLUM SIG	Ignition switch ON	Block the light beam from the auto light optical sensor when the light switch is ON.	On
		Expose the auto light optical sensor to light when the light switch is OFF or ON.	Off
IGN SIG	Ignition switch ON.		On
	Ignition switch ACC.		Off
REV SIG	Ignition switch ON	Selector lever in R position.	On
		Selector lever in any position other than R.	Off

#### TERMINAL LAYOUT

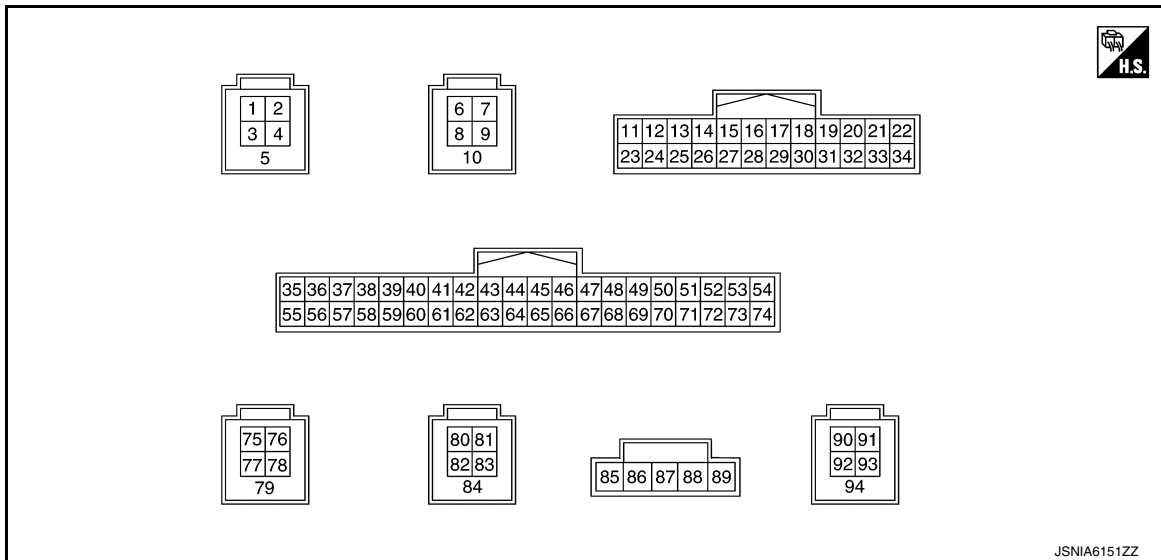

#### PHYSICAL VALUES

Terminal (Wire color)		Description		Condition	Reference value (Approx.)
+	-	Signal name	Input/Output		
1 (G)	—	USB ground	—	—	—
2 (W)	—	USB V BUS signal	Output	—	—

# DISPLAY CONTROL UNIT

< ECU DIAGNOSIS INFORMATION >

[AROUND VIEW MONITOR SYSTEM]

Terminal (Wire color)		Description		Condition	Reference value (Approx.)	A
+	-	Signal name	Input/ Output			B
3 (R)	—	USB D- signal	Input/ Output	—	—	C
4 (L)	—	USB D+ signal	Input/ Output	—	—	D
5 (—)	—	Shield	—	—	—	E
6 (G)	—	USB ground	—	—	—	F
7 (W)	—	USB V BUS signal	Output	—	—	G
8 (R)	—	USB D- signal	Input/ Output	—	—	H
9 (L)	—	USB D+ signal	Input/ Output	—	—	I
10 (—)	—	Shield	—	—	—	J
16 (LG)	—	AV communication signal (L)	Input/ Output	—	—	K
17 (P)	—	CAN-L	Input/ Output	—	—	L
19 (R)	22 (B)	Dimmer signal	Input	[Ignition switch ON] • Either of the following conditions - Lighting switch OFF - Expose the auto light optical sensor to light when the light switch is ON.	0 V	M
				[Ignition switch ON] • Block the light beam from the auto light optical sensor when the light switch is ON.	12.0 V	N
20 (BR)	22 (B)	Reverse signal	Input	[Ignition switch ON] • R position	12.0 V	O
				[Ignition switch ON] • Other than R position	0 V	P
22 (B)	—	Ground	—	[Ignition switch ON]	0 V	Q
26 (BR)	22 (B)	Camera switch signal	Input	[Ignition switch ON] • Camera switch: ON	0 - 2.5 V	R
				[Ignition switch ON] • Camera switch: OFF	3.0 V	S
28 (SB)	—	AV communication signal (H)	Input/ Output	—	—	T
29 (L)	—	CAN-H	Input/ Output	—	—	U
30 (W) <sup>*1</sup> (R) <sup>*2</sup>	22 (B)	Ignition signal	Input	[Ignition switch ON]	Battery voltage	V

# DISPLAY CONTROL UNIT

< ECU DIAGNOSIS INFORMATION >

[AROUND VIEW MONITOR SYSTEM]

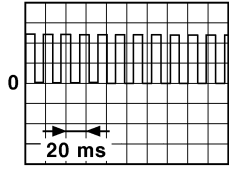
Terminal (Wire color)		Description		Condition	Reference value (Approx.)
+	-	Signal name	Input/ Output		
31 (R)	22 (B)	Vehicle speed signal (8-pulse)	Input	[Ignition switch ON] • When vehicle speed is approx. 40 km/h (25 MPH)	<b>NOTE:</b> The maximum voltage varies depending on the specification (destination unit).  <small>JSNIA0012GB</small>
33 (SB)	22 (B)	ACC power supply	Input	[Ignition switch ACC]	Battery voltage
34 (Y)	22 (B)	Battery power supply	Input	[Ignition switch OFF]	Battery voltage
36 (LG)	—	Composite image signal (-)	—	—	—
38 (—)	—	Shield	—	—	—
40*3 (—)	—	Manufacturer specific signal	—	—	—
42 (G)	—	Sound signal RH (-)	—	—	—
43 (—)	—	Shield	—	—	—
44 (L)	—	Sound signal LH (-)	—	—	—
45 (W)	—	TEL voice signal (-)	—	—	—
46 (—)	—	Shield	—	—	—
47 (R)	—	Voice guidance signal output (-)	—	—	—
48 (B)	—	Voice guidance signal input (-)	—	—	—
49 (W)	—	NS ON/OFF signal	—	—	—
50 (R)	—	Microphone signal ground (With navigation)	—	[Ignition switch ON]	0 V
51 (—)	—	Shield	—	—	—
52 (—)	—	Microphone signal ground	—	[Ignition switch ON]	0 V
54 (W)	—	Camera power supply ground	—	[Ignition switch ON]	0 V
55 (—)	—	Shield	—	—	—

# DISPLAY CONTROL UNIT

< ECU DIAGNOSIS INFORMATION >

[AROUND VIEW MONITOR SYSTEM]

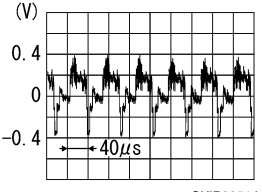
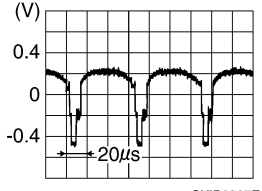
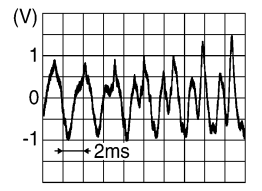
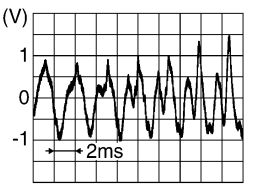
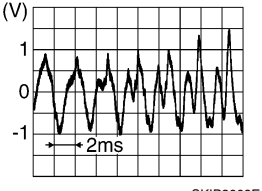
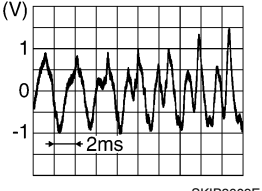
Terminal (Wire color)		Description		Condition	Reference value (Approx.)
+	-	Signal name	Input/ Output		
56 (BR)	36 (LG)	Composite image signal (+)	Input	[Ignition switch ON] • Image is displayed.	 <p style="text-align: right; font-size: small;">SKIB2251J</p>
58 (B)	22 (B)	Camera image signal	Input	[Ignition switch ON] • Image is displayed.	 <p style="text-align: right; font-size: small;">SKIB0827E</p>
60 (W)	—	Sound signal (-)	—	—	—
61 (B)	60 (W)	Sound signal (+)	Input	[Ignition switch ON] • Sound output	 <p style="text-align: right; font-size: small;">SKIB3609E</p>
62 (R)	42 (G)	Sound signal RH (+)	Output	[Ignition switch ON] • Sound output	 <p style="text-align: right; font-size: small;">SKIB3609E</p>
63 (—)	—	Shield	—	—	—
64 (V)	44 (L)	Sound signal LH (+)	Output	[Ignition switch ON] • Sound output	 <p style="text-align: right; font-size: small;">SKIB3609E</p>
65 (B)	45 (W)	TEL voice signal (+)	Input	[Ignition switch ON] • During voice guide output with the switch pressed	 <p style="text-align: right; font-size: small;">SKIB3609E</p>
66 (—)	—	Shield	—	—	—

A  
B  
C  
D  
E  
F  
G  
H  
I  
J  
K  
L  
M  
O  
P

AV

# DISPLAY CONTROL UNIT

< ECU DIAGNOSIS INFORMATION >

[AROUND VIEW MONITOR SYSTEM]

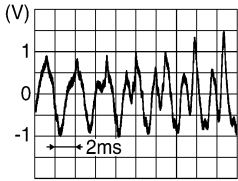
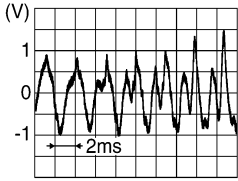
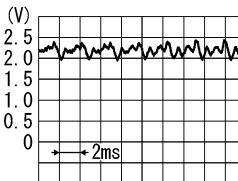
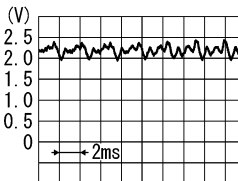
Terminal (Wire color)		Description		Condition	Reference value (Approx.)
+	-	Signal name	Input/ Output		
67 (G)	47 (R)	Voice guidance signal out- put (+)	Output	[Ignition switch ON] • Sound output	 <p style="text-align: right; font-size: small;">SKIB3609E</p>
68 (W)	48 (B)	Voice guidance signal input (+)	Input	[Ignition switch ON] • Sound output	 <p style="text-align: right; font-size: small;">SKIB3609E</p>
69 (-)	-	Shield	-	-	-
70 (G)	50 (R)	Microphone signal (NAVI)	Output	[Ignition switch ON] • Give a voice	 <p style="text-align: right; font-size: small;">PKIB5037J</p>
71 (R) <sup>*4</sup> (G) <sup>*5</sup>	52 (-)	Microphone signal	Output	[Ignition switch ON] • Give a voice	 <p style="text-align: right; font-size: small;">PKIB5037J</p>
72 (L)	22 (B)	Microphone VCC	Output	[Ignition switch ON]	5.0 V
74 (R)	54 (W)	Camera power supply	Output	[Ignition switch ON] • At rear view camera image is dis- played	6.0 V
				[Ignition switch ON] • Except for above	0 V
77 (W)	78 (B)	LVDS (+)	Input/ Output	-	-
78 (B)	-	LVDS (-)	Input/ Output	-	-
79 (-)	-	Shield	-	-	-
80 (G)	-	USB ground	-	-	-
81 (W)	-	USB V BUS signal	Output	-	-
82 (R)	-	USB D- signal	Input/ Output	-	-

# DISPLAY CONTROL UNIT

< ECU DIAGNOSIS INFORMATION >

[AROUND VIEW MONITOR SYSTEM]

Terminal (Wire color)		Description		Condition	Reference value (Approx.)
+	-	Signal name	Input/ Output		
83 (L)	—	USB D+ signal	Input/ Output	—	—
84 (—)	—	Shield	—	—	—
85 (R)	—	USB V BUS signal	Output	—	—
86 (P)	—	USB D- signal	Input/ Output	—	—
87 (W)	—	USB D+ signal	Input/ Output	—	—
89 (—)	—	USB ground	—	—	—
92 (W)	—	LVDS (+)	Input/ Output	—	—
93 (B)	—	LVDS (-)	Input/ Output	—	—
94 (—)	—	Shield	—	—	—

\*1: 2.0L turbo gasoline engine models

\*2: VR30DDTT engine models

\*3: Not used

\*4: With telematics system

\*5: Without telematics system

## Fail-Safe (Display Control Unit)

INFOID:000000013974239

If a malfunction occurs in the Infiniti InTouch, display control unit performs fail-safe activation according to the detected malfunction.

Detection item	Infiniti InTouch operation in fail-safe mode	DTC
Engine speed signal	Active noise cancellation system and active sound enhancement system function are deactivated.	B1F01
Front microphone (LH)	Active noise cancellation function is deactivated.	B1F0B B1F0C B1F0D B1F0E
Front microphone (RH)	Active noise cancellation function is deactivated.	B1F10 B1F11 B1F12 B1F13
Rear microphone	Active noise cancellation function is deactivated.	B1F15 B1F16 B1F17 B1F18
CAN communication	The system using the CAN communication signal from control unit which cannot communicate does not function.	U1000
	The system using the CAN communication signal does not function.	U1010
Display control unit	<ul style="list-style-type: none"> <li>Display is not displayed.</li> <li>Display control unit restart.</li> <li>Display control unit freezes.</li> </ul> <b>NOTE:</b> Symptom other than an item may occur.	U121F

# DISPLAY CONTROL UNIT

< ECU DIAGNOSIS INFORMATION >

[AROUND VIEW MONITOR SYSTEM]

Detection item	Infiniti InTouch operation in fail-safe mode	DTC	
Configuration	A function of display control unit becomes mismatched with a vehicle specification and destination.	U1223	
BOSE amp.	BOSE system does not function.	U1231	
Steering angle sensor	Predictive course line is not displayed.	U1232	
NAVI control unit	<ul style="list-style-type: none"> <li>• Map is not displayed.</li> <li>• Navigation screen does not operate.</li> </ul> <b>NOTE:</b> Symptom other than an item may occur.	U1233	
AV control unit	<ul style="list-style-type: none"> <li>• Sound is not output by a speaker.</li> <li>• CD is not played.</li> <li>• Radio does not operate.</li> </ul> <b>NOTE:</b> Symptom other than an item may occur.	U1234	
GPS antenna	The vehicle positions of a navigation screen differ.	U1244	
AV communication	AV control unit <ul style="list-style-type: none"> <li>• Sound is not output by a speaker.</li> <li>• CD is not played.</li> <li>• Radio does not operate.</li> </ul> <b>NOTE:</b> Symptom other than an item may occur.	U1249	
	BOSE amp.	Sound is not output by a speaker.	U124E
	Integral switch	<ul style="list-style-type: none"> <li>• Integral switch display is not displayed.</li> <li>• Switch operation does not operate.</li> <li>• Touch panel operation does not operate.</li> </ul> <b>NOTE:</b> Symptom other than an item may occur.	U1259
	Around view monitor control unit	Camera image is not displayed.	U125B
	Combination meter	<ul style="list-style-type: none"> <li>• Audio information is not displayed by the information display in the combination meter.</li> <li>• Navigation indicator is not displayed by the information display in the combination meter.</li> <li>• Steering switch does not operate.</li> </ul>	U1267
	Display control unit	The system of ECU which detected abnormalities does not operate.	U1300
		The system which is using AV communication does not operate.	U1310
Satellite radio antenna	Satellite radio is not received.	U1258	
USB communication	NAVI control unit	A navigation menu cannot be selected (hatching display).	U125D
	TCU	Telematics system does not function.	U1266
	External data input box	Audio equipment which connected to USB does not operate.	U12B7
Rear view camera	Rear camera image is not displayed.	U12B8	
Multifunction switch	Multifunction switch operation does not operate.	U12BA	
Radio antenna	Radio is not received.	U12BE	

# DISPLAY CONTROL UNIT

< ECU DIAGNOSIS INFORMATION >

[AROUND VIEW MONITOR SYSTEM]

Detection item	Infiniti InTouch operation in fail-safe mode		DTC
Speaker/squawker/tweeter/ woofer	With BOSE system		
	Door woofer	No sound from door woofer LH or RH.	U1601 U1609
	Door squawker	No sound from door squawker LH or RH.	U1602 U160A
	Tweeter	No sound from tweeter LH or RH.	U1603 U160B
	Front squawker	No sound from front squawker LH or RH.	U1626 U162E
	Center squawker	No sound from center squawker.	U162A
	Rear squawker	No sound from rear squawker LH or RH.	U1716 U171E
	Rear woofer	No sound from rear woofer LH or RH.	U1721 U1729
	Without BOSE system		
	Door speaker	No sound from door speaker LH or RH.	U1600 U1608
Rear speaker	No sound from rear speaker LH or RH.	U1720 U1728	

## DTC Inspection Priority Chart

INFOID:000000013974240

If multiple DTCs are detected simultaneously, check them one by one depending on the following DTC inspection priority chart.

Priority	Detected items (DTC)
1	U1223: CONFIG UNFINISH
2	<ul style="list-style-type: none"> <li>U1000: CAN COMM CIRCUIT</li> <li>U1010: CONTROL UNIT (CAN)</li> </ul>
3	<ul style="list-style-type: none"> <li>B1F01: ENG SPEED SIG ERROR</li> <li>U1249: AUDIO H/U CONN</li> <li>U124E: AMP CONN</li> <li>U1259: 2ND DISP CONN</li> <li>U125B: AROUND CAMERA CONN</li> <li>U1267: METER CONN</li> </ul>

A  
B  
C  
D  
E  
F  
G  
H  
I  
J  
K  
L  
M  
N  
O  
P

AV

# DISPLAY CONTROL UNIT

< ECU DIAGNOSIS INFORMATION >

[AROUND VIEW MONITOR SYSTEM]

Priority	Detected items (DTC)
4	<ul style="list-style-type: none"> <li>• U121F: DISPLAY CONTROL UNIT</li> <li>• U1233: NAVI CONTROL UNIT</li> <li>• U1234: AV CONTROL UNIT</li> <li>• U1300: AV COMM CIRCUIT</li> <li>• U1310: CONTROL UNIT(AV)</li> </ul>
5	<ul style="list-style-type: none"> <li>• B1F0B: ANC MIC1 CIRC OPEN</li> <li>• B1F0C: ANC MIC1 CIRC SHORT</li> <li>• B1F0D: ANC MIC1 CIRC SHORT-BAT</li> <li>• B1F0E: ANC MIC1 CIRC SHORT-GND</li> <li>• B1F10: ANC MIC2 CIRC OPEN</li> <li>• B1F11: ANC MIC2 CIRC SHORT</li> <li>• B1F12: ANC MIC2 CIRC SHORT-BAT</li> <li>• B1F13: ANC MIC2 CIRC SHORT-GND</li> <li>• B1F15: ANC MIC3 CIRC OPEN</li> <li>• B1F16: ANC MIC3 CIRC SHORT</li> <li>• B1F17: ANC MIC3 CIRC SHORT-BAT</li> <li>• B1F18: ANC MIC3 CIRC SHORT-GND</li> <li>• U1232: ST ANGLE SEN CALIB</li> <li>• U1244: GPS ANTENNA CONN</li> <li>• U1258: XM ANTENNA CONN</li> <li>• U125D: DVD NAVI CONN</li> <li>• U1266: TCU CONN</li> <li>• U12B7: USB CONN</li> <li>• U12B8: REAR CAMERA CONN</li> <li>• U12BA: MULTIFUNCTION SWITCH CONN</li> <li>• U12BE: RADIO ANTENA CONN</li> <li>• U1231: AMP TEMP</li> <li>• U1600: FL-DOOR SPEAKER</li> <li>• U1601: FL-DOOR WOOFER</li> <li>• U1602: FL-DOOR SQUAWK</li> <li>• U1603: FL-DOOR TWEETER</li> <li>• U1608: FR-DOOR SPEAKER</li> <li>• U1609: FR-DOOR WOOFER</li> <li>• U160A: FR-DOOR SQUAWK</li> <li>• U160B: FR-DOOR TWEETER</li> <li>• U1626: F-INST L-SQUAWK</li> <li>• U162A: F-INST C-SQUAWK</li> <li>• U162E: F-INST R-SQUAWK</li> <li>• U1716: RL-SIDE SQUAWK</li> <li>• U171E: RR-SIDE SQUAWK</li> <li>• U1720: R-PSHELF L-SPEAKER</li> <li>• U1721: R-PSHELF L-WOOFER</li> <li>• U1728: R-PSHELF R-SPEAKER</li> <li>• U1729: R-PSHELF R-WOOFER</li> </ul>

## DTC Index

INFOID:0000000013974241

## SELF-DIAGNOSIS RESULTS DISPLAY ITEM

DTC	CONSULT display	Reference
B1F01	ENG SPEED SIG ERROR	<a href="#">AV-295, "WITH BOSE SYSTEM : DTC Description"</a>
B1F0B	ANC MIC1 CIRC OPEN	<a href="#">AV-304, "DTC Description"</a>
B1F0C	ANC MIC1 CIRC SHORT	<a href="#">AV-304, "DTC Description"</a>
B1F0D	ANC MIC1 CIRC SHORT-BAT	<a href="#">AV-304, "DTC Description"</a>
B1F0E	ANC MIC1 CIRC SHORT-GND	<a href="#">AV-304, "DTC Description"</a>
B1F10	ANC MIC2 CIRC OPEN	<a href="#">AV-309, "DTC Description"</a>
B1F11	ANC MIC2 CIRC SHORT	<a href="#">AV-309, "DTC Description"</a>
B1F12	ANC MIC2 CIRC SHORT-BAT	<a href="#">AV-309, "DTC Description"</a>

# DISPLAY CONTROL UNIT

< ECU DIAGNOSIS INFORMATION >

[AROUND VIEW MONITOR SYSTEM]

DTC	CONSULT display	Reference	
B1F13	ANC MIC2 CIRC SHORT-GND	<a href="#">AV-309, "DTC Description"</a>	
B1F15	ANC MIC3 CIRC OPEN	<a href="#">AV-314, "DTC Description"</a>	
B1F16	ANC MIC3 CIRC SHORT	<a href="#">AV-314, "DTC Description"</a>	
B1F17	ANC MIC3 CIRC SHORT-BAT	<a href="#">AV-314, "DTC Description"</a>	
B1F18	ANC MIC3 CIRC SHORT-GND	<a href="#">AV-314, "DTC Description"</a>	
U1000	CAN COMM CIRCUIT	<a href="#">AV-327, "DISPLAY CONTROL UNIT : DTC Description"</a>	
U1010	CONTROL UNIT (CAN)	<a href="#">AV-330, "DISPLAY CONTROL UNIT : DTC Description"</a>	
U121F	DISPLAY CONTROL UNIT	<a href="#">AV-332, "DTC Description"</a>	
U1223	CONFIG UNFINISH	<a href="#">AV-333, "DTC Description"</a>	
U1231	AMP TEMP	<a href="#">AV-334, "DTC Description"</a>	
U1232	ST ANGLE SEN CALIB	<a href="#">AV-335, "DTC Description"</a>	
U1233	NAVI CONTROL UNIT	<a href="#">AV-336, "DTC Description"</a>	
U1234	AV CONTROL UNIT	<a href="#">AV-337, "DTC Description"</a>	
U1244	GPS ANTENNA CONN	<a href="#">AV-338, "DTC Description"</a>	
U1249	AUDIO H/U CONN	<a href="#">AV-339, "DTC Description"</a>	
U124E	AMP CONN	<a href="#">AV-341, "DTC Description"</a>	
U1258	XM ANTENNA CONN	GND-SHORT	<a href="#">AV-343, "DTC Description"</a>
		OPEN	
U1259	2ND DISP CONN	<a href="#">AV-345, "DTC Description"</a>	
U125B	AROUND CAMERA CONN	<a href="#">AV-347, "DTC Description"</a>	
U125D	DVD NAVI CONN	<a href="#">AV-349, "DTC Description"</a>	
U1266	TCU CONN	<a href="#">AV-350, "DTC Description"</a>	
U1267	METER CONN	<a href="#">AV-352, "DTC Description"</a>	
U12B7	USB CONN	<a href="#">AV-354, "DTC Description"</a>	
U12B8	REAR CAMERA CONN	<a href="#">AV-355, "DTC Description"</a>	
U12BA	MULTIFUNCTION SWITCH CONN	<a href="#">AV-357, "DTC Description"</a>	
U12BE	RADIO ANTENA CONN	GND-SHORT	<a href="#">AV-359, "DTC Description"</a>
		OPEN	
U1300	AV COMM CIRCUIT	<a href="#">AV-361, "DTC Description"</a>	
U1310	CONTROL UNIT(AV)	<a href="#">AV-363, "DTC Description"</a>	
U1600	FL-DOOR SPEAKER	OPEN	<a href="#">AV-364, "DTC Description"</a>
		SHORT	
		GND-SHORT	
		VB-SHORT	
U1601	FL-DOOR WOOFER	OPEN	<a href="#">AV-367, "DTC Description"</a>
		SHORT	
		GND-SHORT	
		VB-SHORT	
U1602	FL-DOOR SQUAWK	OPEN	<a href="#">AV-370, "DTC Description"</a>
		SHORT	
		GND-SHORT	
		VB-SHORT	

A  
B  
C  
D  
E  
F  
G  
H  
I  
J  
K  
L  
M  
O  
P

AV

# DISPLAY CONTROL UNIT

< ECU DIAGNOSIS INFORMATION >

[AROUND VIEW MONITOR SYSTEM]

DTC	CONSULT display	Reference
U1603	FL-DOOR TWEETER	OPEN
		SHORT
		GND-SHORT
		VB-SHORT
		<a href="#">AV-373, "DTC Description"</a>
U1608	FR-DOOR SPEAKER	OPEN
		SHORT
		GND-SHORT
		VB-SHORT
		<a href="#">AV-364, "DTC Description"</a>
U1609	FR-DOOR WOOFER	OPEN
		SHORT
		GND-SHORT
		VB-SHORT
		<a href="#">AV-367, "DTC Description"</a>
U160A	FR-DOOR SQUAWK	OPEN
		SHORT
		GND-SHORT
		VB-SHORT
		<a href="#">AV-370, "DTC Description"</a>
U160B	FR-DOOR TWEETER	OPEN
		SHORT
		GND-SHORT
		VB-SHORT
		<a href="#">AV-373, "DTC Description"</a>
U1626	F-INST L-SQUAWK	OPEN
		SHORT
		GND-SHORT
		VB-SHORT
		<a href="#">AV-376, "DTC Description"</a>
U162A	F-INST C-SQUAWK	OPEN
		SHORT
		GND-SHORT
		VB-SHORT
		<a href="#">AV-379, "DTC Description"</a>
U162E	F-INST R-SQUAWK	OPEN
		SHORT
		GND-SHORT
		VB-SHORT
		<a href="#">AV-376, "DTC Description"</a>
U1716	RL-SIDE SQUAWK	OPEN
		SHORT
		GND-SHORT
		VB-SHORT
		<a href="#">AV-381, "DTC Description"</a>
U171E	RR-SIDE SQUAWK	OPEN
		SHORT
		GND-SHORT
		VB-SHORT
		<a href="#">AV-381, "DTC Description"</a>
U1720	R-PSHELF L-SPEAKER	OPEN
		SHORT
		GND-SHORT
		VB-SHORT
		<a href="#">AV-384, "DTC Description"</a>

# DISPLAY CONTROL UNIT

< ECU DIAGNOSIS INFORMATION >

[AROUND VIEW MONITOR SYSTEM]

DTC	CONSULT display	Reference
U1721	R-PSHELF L-WOOFER	OPEN
		SHORT
		GND-SHORT
		VB-SHORT
U1728	R-PSHELF R-SPEAKER	OPEN
		SHORT
		GND-SHORT
		VB-SHORT
U1729	R-PSHELF R-WOOFER	OPEN
		SHORT
		GND-SHORT
		VB-SHORT

A  
B  
C  
D  
E  
F  
G  
H  
I  
J  
K  
L  
M

AV

O  
P

# AROUND VIEW MONITOR CONTROL UNIT

< ECU DIAGNOSIS INFORMATION >

[AROUND VIEW MONITOR SYSTEM]

## AROUND VIEW MONITOR CONTROL UNIT

### Reference Value

INFOID:000000013717482

#### VALUES ON THE DIAGNOSIS TOOL

**NOTE:**

The following table includes information (items) inapplicable to this vehicle. For information (items) applicable to this vehicle, refer to CONSULT display items.

Monitor Item	Condition		Value/Status
ST ANGLE SENSOR SIGNAL [On/Off]	Ignition switch ON	When steering angle sensor signal is input	On
		Other than the above	Off
REVERSE SIGNAL [On/Off]	Ignition switch ON	R position	On
		Other than R position	Off
VEHICLE SPEED SIGNAL [On/Off]	Ignition switch ON	When vehicle speed is input	On
		Other than the above	Off
CAMERA SWITCH SIGNAL [On/Off]	Ignition switch ON	When camera switch signal is input	On
		Other than the above	Off
CAMERA OFF SIGNAL [On/Off]	Ignition switch ON	When camera OFF signal is input	On
		Other than the above	Off
ST ANGLE SENSOR TYPE [Absolute]	Ignition switch ON	—	Absolute
STEERING GEAR RATIO TYPE [TYPE1]	Ignition switch ON	—	TYPE1
STEERING POSITION [LHD]	Ignition switch ON	LHD models	LHD
REAR CAMERA IMAGE SIGNAL [OK/NG]	Ignition switch ON	When rear camera image signal input status is normal	OK
		When rear view camera image signal input status is not normal	NG
R-CAMERA COMM STATUS [OK/NG]	Ignition switch ON	When communication status with rear camera is normal	OK
		When communication status with rear camera is not normal	NG
R-CAMERA COMM LINE [OK/NG]	Ignition switch ON	When communication line with rear camera is normal	OK
		When communication line with rear camera is not normal	NG
F-CAMERA IMAGE SIGNAL [OK/NG]	Ignition switch ON	When front camera image signal input status is normal	OK
		When front camera image signal input status is not normal	NG
F-CAMERA COMM STATUS [OK/NG]	Ignition switch ON	When communication status with front camera is normal	OK
		When communication status with front camera is not normal	NG
F-CAMERA COMM LINE [OK/NG]	Ignition switch ON	When communication line with front camera is normal	OK
		When communication line with front camera is not normal	NG
DR-SIDE CAMERA IMAGE SIG [OK/NG]	Ignition switch ON	When side camera LH image signal input status is normal	OK
		When side camera LH image signal input status is not normal	NG

# AROUND VIEW MONITOR CONTROL UNIT

< ECU DIAGNOSIS INFORMATION >

[AROUND VIEW MONITOR SYSTEM]

Monitor Item	Condition		Value/Status
DR CAMERA COMM STATUS [OK/NG]	Ignition switch ON	When communication status with side camera LH is normal	OK
		When communication status with side camera LH is not normal	NG
DR-SIDE CAMERA COMM LINE [OK/NG]	Ignition switch ON	When communication line with side camera LH is normal	OK
		When communication line with side camera LH is not normal	NG
PA-SIDE CAMERA IMAGE SIG [OK/NG]	Ignition switch ON	When side camera RH image signal input status is normal	OK
		When side camera RH image signal input status is not normal	NG
PA CAMERA COMM STATUS [OK/NG]	Ignition switch ON	When communication status with side camera RH is normal	OK
		When communication status with side camera RH is not normal	NG
PA-SIDE CAMERA COMM LINE [OK/NG]	Ignition switch ON	When communication line with side camera RH is normal	OK
		When communication line with side camera RH is not normal	NG
ACC	Ignition switch ACC		On
	Ignition switch OFF		Off
FOLDING MOTOR VOLT 1 [On/Off]	Ignition switch ON	Driver side door mirror is in expanded status	On
		Driver side door mirror is in retracted status	Off
FOLDING MOTOR VOLT 2 [On/Off]	Ignition switch ON	Driver side door mirror is in expanded status	Off
		Driver side door mirror is in retracted status	On

## TERMINAL LAYOUT

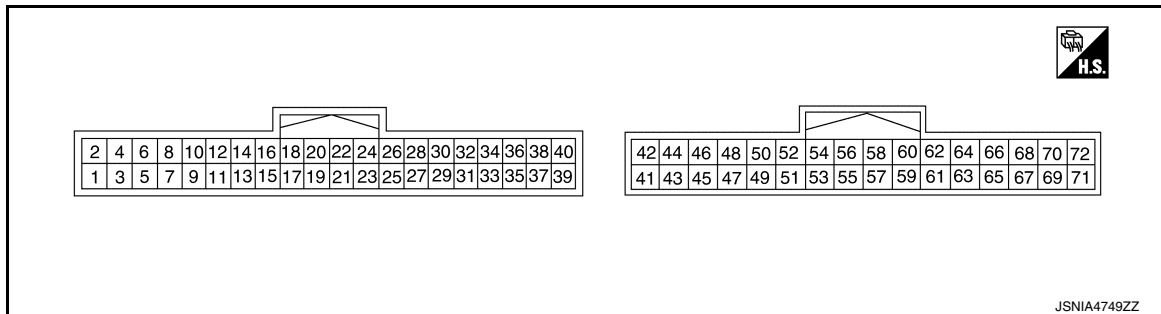

## PHYSICAL VALUES

Terminal (Wire color)		Description		Condition	Reference value (Approx.)
+	-	Signal name	Input/ Output		
1 (B)	Ground	Ground	—	[Ignition switch ON]	0 V
2 (Y)	1 (B)	Battery power supply	Input	[Ignition switch OFF]	Battery voltage
3 (LG)	1 (B)	Ignition signal	Input	[Ignition switch ON]	Battery voltage
4 (P)	1 (B)	ACC power supply	Input	[Ignition switch ACC]	Battery voltage

# AROUND VIEW MONITOR CONTROL UNIT

< ECU DIAGNOSIS INFORMATION >

[AROUND VIEW MONITOR SYSTEM]

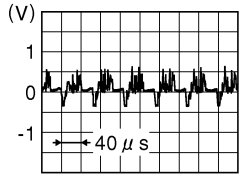
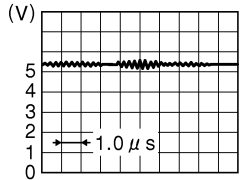
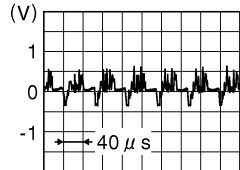
Terminal (Wire color)		Description		Condition	Reference value (Approx.)
+	-	Signal name	Input/ Output		
19 (P)	—	AV communication signal (H)	Input/ Output	—	—
20 (LG)	—	AV communication signal (L)	Input/ Output	—	—
23 (—)	—	AV communication signal ground	—	—	—
25 (BG)	1 (B)	Reverse signal	Input	[Ignition switch ON] • R position	12.0 V
				[Ignition switch ON] • Other than R position	0 V
27 (L)	—	CAN-H	Input/ Output	—	—
28 (P) <sup>*1</sup> (R) <sup>*2</sup>	—	CAN-L	Input/ Output	—	—
29 (—)	—	CAN communication signal ground	—	—	—
47 (B)	48 (—)	Camera image signal	Output	[Ignition switch ON] • CAMERA switch is ON or shift position is R position	 <small>JSNIA0834GB</small>
48 (—)	Ground	Camera image signal ground	—	[Ignition switch ON]	0 V
49 (W)	52 (R)	Rear camera commu- nication signal	Input/ Output	[Ignition switch ON] • CAMERA switch is ON or shift position is R position	 <small>JSNIA0836GB</small>
50 (B)	52 (R)	Rear camera power supply	Output	[Ignition switch ON]	6.0 V
52 (R)	Ground	Rear camera ground	—	[Ignition switch ON]	0 V
53 (G)	54 (—)	Rear camera image signal (+)	Input	[Ignition switch ON] • CAMERA switch is ON or shift position is R position	 <small>JSNIA0834GB</small>
54 (—)	Ground	Rear camera image signal (-)	—	[Ignition switch ON]	0 V

# AROUND VIEW MONITOR CONTROL UNIT

< ECU DIAGNOSIS INFORMATION >

[AROUND VIEW MONITOR SYSTEM]

Terminal (Wire color)		Description	Input/ Output	Condition	Reference value (Approx.)
+	-				
55 (GR)	58 (P)	Side camera driver side communication signal	Input/ Output	[Ignition switch ON] • CAMERA switch is ON or shift position is R position	<p style="text-align: right; font-size: small;">JSNIA0836GB</p>
56 (V)	58 (P)	Side camera driver side power supply	Output	[Ignition switch ON]	6.0 V
58 (P)	Ground	Side camera driver side ground	—	[Ignition switch ON]	0 V
59 (LG)	60 (—)	Side camera driver side image signal (+)	Input	[Ignition switch ON] • CAMERA switch is ON or shift position is R position	<p style="text-align: right; font-size: small;">JSNIA0834GB</p>
60 (—)	Ground	Side camera driver side image signal (-)	—	[Ignition switch ON]	0 V
61 (W)	64 (R)	Side camera passen- ger side communica- tion signal	Input/ Output	[Ignition switch ON] • CAMERA switch is ON or shift position is R position	<p style="text-align: right; font-size: small;">JSNIA0836GB</p>
62 (L)	64 (R)	Side camera passen- ger side power supply	Output	[Ignition switch ON]	6.0 V
64 (R)	Ground	Side camera passen- ger side ground	—	[Ignition switch ON]	0 V
65 (G)	66 (—)	Side camera passen- ger side image signal (+)	Input	[Ignition switch ON] • CAMERA switch is ON or shift position is R position	<p style="text-align: right; font-size: small;">JSNIA0834GB</p>
66 (—)	Ground	Side camera passen- ger side image signal (-)	—	[Ignition switch ON]	0 V
67 (B)	70 (G)	Front camera com- munication signal	Input/ Output	[Ignition switch ON] • CAMERA switch is ON or shift position is R position	<p style="text-align: right; font-size: small;">JSNIA0836GB</p>

A  
B  
C  
D  
E  
F  
G  
H  
I  
J  
K  
L  
M  
O  
P

AV

# AROUND VIEW MONITOR CONTROL UNIT

< ECU DIAGNOSIS INFORMATION >

[AROUND VIEW MONITOR SYSTEM]

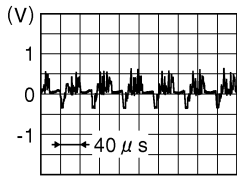
Terminal (Wire color)		Description		Condition	Reference value (Approx.)
+	-	Signal name	Input/ Output		
68 (W)	70 (G)	Front camera power supply	Output	[Ignition switch ON]	6.0 V
70 (G)	Ground	Front camera ground	—	[Ignition switch ON]	0 V
71 (R)	72 (—)	Front camera image signal (+)	Input	[Ignition switch ON] • CAMERA switch is ON or shift position is R position	
72 (—)	Ground	Front camera image signal (-)	—	[Ignition switch ON]	0 V

\*1: With ADAS  
\*2: Without ADAS

## Fail-Safe (Around View Monitor Control Unit)

INFOID:0000000013717483

DTC Display contents of CONSULT	Malfunction detection condition	Fail-safe condition
U0428: ST ANGLE SENSOR CALIBRATION	Neutral position adjustment of steering angle sensor is not complete.	<ul style="list-style-type: none"> <li>• Predicted course line is not displayed.</li> <li>• MOD (Moving Object Detection) function is stopped.</li> <li>• Front tire angle display is stopped.</li> <li>• Using "SETTING" menu display, switch each indicator of predicted course line display and MOD switch to "OFF" (turn OFF) so that switch operation cannot be performed.</li> </ul>
U1000: CAN COMM CIRCUIT	When around view monitor control unit cannot transmit/receive CAN communication signal continuously for 2 seconds or more.	<p>The following functions are stopped</p> <ul style="list-style-type: none"> <li>• When communication of steering angle sensor signal is not normal                             <ul style="list-style-type: none"> <li>- Predicted course line is not displayed.</li> <li>- MOD (Moving Object Detection) function is stopped.</li> <li>- Front tire angle display is stopped.</li> <li>- Using "SETTING" menu display, switch each indicator of predicted course line display and MOD switch to "OFF" (turn OFF) so that switch operation cannot be performed.</li> </ul> </li> <li>• When communication of vehicle signal, wheel speed sensor signal, and shift signal is not normal                             <ul style="list-style-type: none"> <li>- Predicted course line is not displayed.</li> <li>- MOD (Moving Object Detection) function is stopped.</li> <li>- Using "SETTING" menu display, switch each indicator of predicted course line display and MOD switch to "OFF" (turn OFF) so that switch operation cannot be performed</li> </ul> </li> <li>• When communication of sonar signal is not normal                             <ul style="list-style-type: none"> <li>- Predicted course line is not displayed.</li> </ul> </li> </ul>

# AROUND VIEW MONITOR CONTROL UNIT

< ECU DIAGNOSIS INFORMATION >

[AROUND VIEW MONITOR SYSTEM]

DTC Display contents of CONSULT	Malfunction detection condition	Fail-safe condition
U111A: REAR CAMERA IMAGE SIGNAL	No-signal status of rear camera image signal is continued for 500 ms or more while ignition switch is ON. <b>NOTE:</b> Current malfunction is displayed only and is not saved.	Camera image is not displayed (Gray screen display).
U111B: SIDE CAMERA RH IMAGE SIGNAL	No-signal status of side camera RH image signal is continued for 500 ms or more while ignition switch is ON. <b>NOTE:</b> Current malfunction is displayed only and is not saved.	
U111C: FRONT CAMERA IMAGE SIGNAL	No-signal status of rear camera image signal is continued for 500 ms or more while ignition switch is ON. <b>NOTE:</b> Current malfunction is displayed only and is not saved.	
U111D: SIDE CAMERA LH IMAGE SIGNAL	No-signal status of side camera LH image signal is continued for 500 ms or more while ignition switch is ON. <b>NOTE:</b> Current malfunction is displayed only and is not saved.	
U1232: ST ANGLE SEN CALIB	Neutral position adjustment of steering angle sensor is performed. NG signal from steering angle sensor is received.	<ul style="list-style-type: none"> <li>• Predicted course line is not displayed.</li> <li>• MOD (Moving Object Detection) function is stopped.</li> <li>• Tire icon is stopped.</li> <li>• Using "SETTING" menu display, switch each indicator of predicted course line display and MOD switch to "OFF" (turn OFF) so that switch operation cannot be performed.</li> </ul>
U1302: CAMERA POWER VOLT	Camera power supply voltage does not satisfy the following conditions for 2 seconds or more when ignition switch is turned ON. <ul style="list-style-type: none"> <li>• When supplemental lighting power supply output is ON: 5.9 – 6.5 V.</li> <li>• When OFF: 0 V by camera power supply measurement.</li> </ul>	Camera power output is stopped.
U1304: CAMERA IMAGE CALIB	<ul style="list-style-type: none"> <li>• When camera calibration is incomplete.</li> <li>• When camera information in around view monitor control unit and information read from camera are not the same.</li> </ul> <b>NOTE:</b> Current malfunction is displayed only and is not saved.	Unmatched icon  display (red) is displayed (applicable for unmatched camera only).
U1305: CONFIG UNFINISH	The vehicle setting of around view monitor control unit is incomplete. <b>NOTE:</b> Current malfunction is displayed only and is not saved.	Operation is according to the vehicle setting value as default value.



A  
B  
C  
D  
E  
F  
G  
H  
I  
J  
K  
L  
M  
O  
P

AV

# AROUND VIEW MONITOR CONTROL UNIT

< ECU DIAGNOSIS INFORMATION >

[AROUND VIEW MONITOR SYSTEM]

DTC Display contents of CONSULT	Malfunction detection condition	Fail-safe condition
Other	When around view monitor control unit is not normal.	Switch to camera screen is not allowed.
	When communication between around view monitor control unit and each camera is not normal.	On applicable camera screen  marking (Red) is displayed.
	When communication line between around view monitor control unit and each camera image line are affected by electromagnetic noises.	On applicable camera image screen,  display (Blue) is displayed.

## DTC Inspection Priority Chart

INFOID:000000013717484

If multiple DTCs are detected simultaneously, check them one by one depending on the following DTC inspection priority chart.

Priority	Detected items (DTC)
1	U1305: CONFIG UNFINISH
2	<ul style="list-style-type: none"> <li>• U1000: CAN COMM CIRCUIT</li> <li>• U1010: CONTROL UNIT (CAN)</li> </ul>
3	<ul style="list-style-type: none"> <li>• U0428: ST ANGLE SENSOR CALIBRATION</li> <li>• U111A: REAR CAMERA IMAGE SIGNAL</li> <li>• U111B: SIDE CAMERA RH IMAGE SIGNAL</li> <li>• U111C: FRONT CAMERA IMAGE SIGNAL</li> <li>• U111D: SIDE CAMERA LH IMAGE SIGNAL</li> <li>• U1232: ST ANGLE SEN CALIB</li> <li>• U1302: CAMERA POWER VOLT</li> <li>• U1303: LED POWER SUPPLY VOLT</li> <li>• U1304: CAMERA IMAGE CALIB</li> </ul>

## DTC Index

INFOID:000000013717485

DTC	CONSULT display	Refer to
U0428	ST ANGLE SENSOR CALIBRATION	<a href="#">AV-600, "DTC Description"</a>
U1000	CAN COMM CIRCUIT	<a href="#">AV-602, "AROUND VIEW MONITOR CONTROL UNIT : DTC Description"</a>
U1010	CONTROL UNIT (CAN)	<a href="#">AV-605, "AROUND VIEW MONITOR CONTROL UNIT : DTC Description"</a>
U111A	REAR CAMERA IMAGE SIGNAL	<a href="#">AV-607, "DTC Description"</a>
U111B	SIDE CAMERA RH IMAGE SIGNAL	<a href="#">AV-610, "DTC Description"</a>
U111C	FRONT CAMERA IMAGE SIGNAL	<a href="#">AV-613, "DTC Description"</a>
U111D	SIDE CAMERA LH IMAGE SIGNAL	<a href="#">AV-616, "DTC Description"</a>
U1232	ST ANGLE SEN CALIB	<a href="#">AV-619, "DTC Description"</a>
U1302	CAMERA POWER VOLT	<a href="#">AV-620, "DTC Description"</a>
U1303	LED POWER SUPPLY VOLT	<a href="#">AV-624, "DTC Description"</a>
U1304	CAMERA IMAGE CALIB	<a href="#">AV-625, "DTC Description"</a>
U1305	CONFIG UNFINISH	<a href="#">AV-626, "DTC Description"</a>

# SONAR CONTROL UNIT

< ECU DIAGNOSIS INFORMATION >

[AROUND VIEW MONITOR SYSTEM]

## SONAR CONTROL UNIT

### Reference Value

INFOID:000000013717486

### VALUES ON THE DIAGNOSIS TOOL

**NOTE:**

The following table includes information (items) inapplicable to this vehicle. For information (items) applicable to this vehicle, refer to CONSULT display items.

Monitor item	Condition		Value/Status
VEHICLE SPEED	While driving		Input value of vehicle speed signal
SONAR C/U POWER SUPPLY	Ignition switch ON		Battery voltage
SENSOR VOLTAGE	Ignition switch ON		Approx. 8.0 V
DETECTION MODE	Ignition switch ON		Mode 1
			Mode 2
SW OPRT AFTR IGN ON	Switch operation after ignition ON.		Yes
			No
SONAR TEMPORARY OFF	Ignition switch ON, selector lever in R (reverse) position.		No
	When selector lever is in any position other than R (reverse).		Yes
SONAR PERMANENT OFF	Ignition switch ON, selector lever in R (reverse) position.		No
	When selector lever is in any position other than R (reverse).		Yes
P N RANGE	Ignition switch ON	Selector lever P or N position	On
		Other than the above	Off
LED	When LED is OFF.		Off
	When LED is ON.		On
TRAILER CONNECT	No trailer connected to trailer hitch.		N CON
	Trailer connected to trailer hitch.		CON
REVERSE RANGE	Ignition switch ON	Selector lever R position	On
		Other than the above	Off
SHRT DST FRM RR SENS	Ignition switch ON	An obstacle exists in the vicinity of rear corner/ center sensor. [Approx. 27 - 70 cm (10.63 - 27.56 in)]	Almost agree with the distance from the closest obstacle to rear bumper. [27 - 70 cm (10.63 - 27.56 in)]
		No obstacle exists in the vicinity of rear corner/ center sensor.	255 cm (100.39 in)
SHRT DST FRM FR SENS	Ignition switch ON	An obstacle exists in the vicinity of front corner/ center sensor. [Approx. 27 - 70 cm (10.63 - 27.56 in)]	Almost agree with the distance from the closest obstacle to front bumper. [27 - 70 cm (10.63 - 27.56 in)]
		No obstacle exists in the vicinity of front corner/ center sensor.	255 cm (100.39 in)
COR[RL]	Ignition switch ON	An obstacle exists in the vicinity of rear corner sensor LH. [Approx. 27 - 70 cm (10.63 - 27.56 in)]	Almost agree with the distance from an obstacle to rear corner sensor LH. [27 - 70 cm (10.63 - 27.56 in)]
		No obstacle exists in the vicinity of rear corner sensor LH.	255 cm (100.39 in)
COR[RL]->CEN[RL]/CEN[R]	Ignition switch ON	When obstacles exist around rear bumper.	Distance between rear bumper and obstacle.
CEN[RL]/CEN[R]->COR[RL]	Ignition switch ON	When obstacles exist around rear bumper.	Distance between rear bumper and obstacle.

# SONAR CONTROL UNIT

< ECU DIAGNOSIS INFORMATION >

[AROUND VIEW MONITOR SYSTEM]

Monitor item	Condition		Value/Status
CEN[RL]/CEN[R]	Ignition switch ON	An obstacle exists in the vicinity of rear center sensor LH. [Approx. 27 - 70 cm (10.63 - 27.56 in)]	Almost agree with the distance from an obstacle to rear center sensor LH. [27 - 70 cm (10.63 - 27.56 in)]
		No obstacle exists in the vicinity of rear center sensor LH.	255 cm (100.39 in)
CEN[RL]->CEN[RR]	Ignition switch ON	When obstacles exist around rear bumper.	Distance between rear bumper and obstacle.
CEN[RR]->CEN[RL]	Ignition switch ON	When obstacles exist around rear bumper.	Distance between rear bumper and obstacle.
CEN[RR]	Ignition switch ON	An obstacle exists in the vicinity of rear center sensor RH. [Approx. 27 - 70 cm (10.63 - 27.56 in)]	Almost agree with the distance from an obstacle to rear center sensor RH. [27 - 70 cm (10.63 - 27.56 in)]
		No obstacle exists in the vicinity of rear center sensor RH.	255 cm (100.39 in)
CEN[RR]/CEN[R]->COR[RR]	Ignition switch ON	When obstacles exist around rear bumper.	Distance between rear bumper and obstacle.
COR[RR]->CEN[RR]/CEN[R]	Ignition switch ON	When obstacles exist around rear bumper.	Distance between rear bumper and obstacle.
COR[RR]	Ignition switch ON	An obstacle exists in the vicinity of rear corner sensor RH. [Approx. 27 - 70 cm (10.63 - 27.56 in)]	Almost agree with the distance from an obstacle to rear corner sensor RH. [27 - 70 cm (10.63 - 27.56 in)]
		No obstacle exists in the vicinity of rear corner sensor RH.	255 cm (100.39 in)
COR[FL]	Ignition switch ON	An obstacle exists in the vicinity of front corner sensor LH. [Approx. 27 - 70 cm (10.63 - 27.56 in)]	Almost agree with the distance from an obstacle to front corner sensor LH. [27 - 70 cm (10.63 - 27.56 in)]
		No obstacle exists in the vicinity of front corner sensor LH.	255 cm (100.39 in)
COR[FL]->CEN[FL]/CEN[F]	Ignition switch ON	When obstacles exist around front bumper.	Distance between front bumper and obstacle.
CEN[FL]/CEN[F]->COR[FL]	Ignition switch ON	When obstacles exist around front bumper.	Distance between front bumper and obstacle.
CEN[FL]/CEN[F]	Ignition switch ON	An obstacle exists in the vicinity of front center sensor LH. [Approx. 27 - 70 cm (10.63 - 27.56 in)]	Almost agree with the distance from an obstacle to front center sensor LH. [27 - 70 cm (10.63 - 27.56 in)]
		No obstacle exists in the vicinity of front center sensor LH.	255 cm (100.39 in)
CEN[FL]->CEN[FR]	Ignition switch ON	When obstacles exist around front bumper.	Distance between front bumper and obstacle.
CEN[FR]->CEN[FL]	Ignition switch ON	When obstacles exist around front bumper.	Distance between front bumper and obstacle.
CEN[FR]	Ignition switch ON	An obstacle exists in the vicinity of front center sensor RH. [Approx. 27 - 70 cm (10.63 - 27.56 in)]	Almost agree with the distance from an obstacle to front center sensor RH. [27 - 70 cm (10.63 - 27.56 in)]
		No obstacle exists in the vicinity of front center sensor RH.	255 cm (100.39 in)
CEN[FR]/CEN[F]->COR[FR]	Ignition switch ON	When obstacles exist around front bumper.	Distance between front bumper and obstacle.
COR[FR]->CEN[FR]/CEN[F]	Ignition switch ON	When obstacles exist around front bumper.	Distance between front bumper and obstacle.

# SONAR CONTROL UNIT

< ECU DIAGNOSIS INFORMATION >

[AROUND VIEW MONITOR SYSTEM]

Monitor item	Condition		Value/Status
COR[FR]	Ignition switch ON	An obstacle exists in the vicinity of front corner sensor RH. [Approx. 27 - 70 cm (10.63 - 27.56 in)]	Almost agree with the distance from an obstacle to front corner sensor RH. [27 - 70 cm (10.63 - 27.56 in)]
		No obstacle exists in the vicinity of front corner sensor RH.	255 cm (100.39 in)
RVRB TIME COR[RL]	Ignition switch ON		Approx. 1.60 ms
RVRB TIME COR[RR]	Ignition switch ON		Approx. 1.60 ms
RVRB TIME CEN[RL]	Ignition switch ON		Approx. 1.60 ms
RVRB TIME CEN[RR]	Ignition switch ON		Approx. 1.60 ms
RVRB TIME COR[FL]	Ignition switch ON		Approx. 1.60 ms
RVRB TIME COR[FR]	Ignition switch ON		Approx. 1.60 ms
RVRB TIME CEN[FL]	Ignition switch ON		Approx. 1.60 ms
RVRB TIME CEN[FR]	Ignition switch ON		Approx. 1.60 ms

## TERMINAL LAYOUT

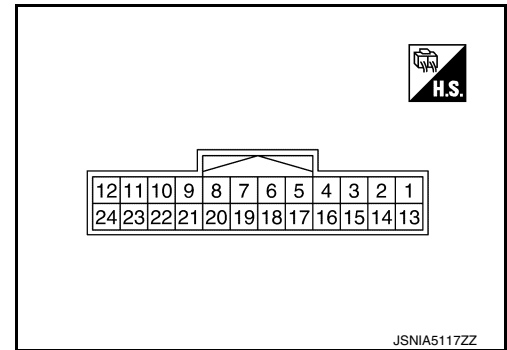

## PHYSICAL VALUES

Terminal No. (Wire color)		Description		Condition	Value (Approx.)
+	-	Signal name	Input/ Output		
1 (SB)	13 (B)	Center sensor signal front RH	Input	[Ignition switch ON]	<p style="text-align: right; font-size: small;">JSNIA0837GB</p>
2 (LG)	13 (B)	Center sensor signal front LH	Input	[Ignition switch ON]	<p style="text-align: right; font-size: small;">JSNIA0837GB</p>

# SONAR CONTROL UNIT

< ECU DIAGNOSIS INFORMATION >

[AROUND VIEW MONITOR SYSTEM]

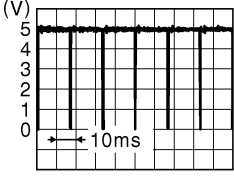
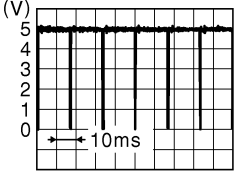
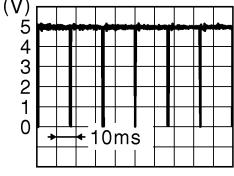
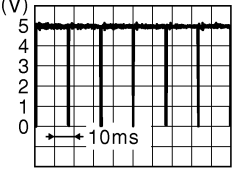
Terminal No. (Wire color)		Description		Condition	Value (Approx.)
+	-	Signal name	Input/ Output		
3 (W)	13 (B)	Corner sensor signal front LH	Input	[Ignition switch ON]	 <p style="text-align: right; font-size: small;">JSNIA0837GB</p>
4 (GR)	13 (B)	Corner sensor signal front RH	Input	[Ignition switch ON]	 <p style="text-align: right; font-size: small;">JSNIA0837GB</p>
5 (L)	—	CAN-H	Input/ Output	—	—
6 (R) <sup>*1</sup> (P) <sup>*2</sup>	—	CAN-L	Input/ Output	—	—
9 (G)	14 (B)	Center sensor signal rear RH	Input	[Ignition switch ON]	 <p style="text-align: right; font-size: small;">JSNIA0837GB</p>
10 (BG)	14 (B)	Corner sensor signal rear RH	Input	[Ignition switch ON]	 <p style="text-align: right; font-size: small;">JSNIA0837GB</p>
12 (W) <sup>*3</sup> (R) <sup>*4</sup>	15 (B)	Ignition power supply	Input	[Ignition switch ON]	Battery voltage
13 (B)	Ground	Front sensor ground	—	—	0 V
14 (B)	Ground	Rear sensor ground	—	—	0 V
15 (B)	Ground	Ground	—	—	0 V

# SONAR CONTROL UNIT

< ECU DIAGNOSIS INFORMATION >

[AROUND VIEW MONITOR SYSTEM]

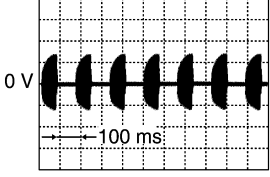
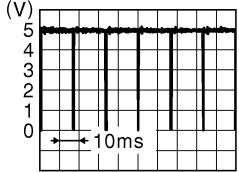
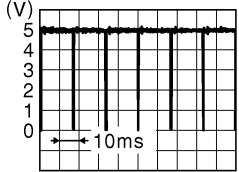
Terminal No. (Wire color)		Description		Condition	Value (Approx.)
+	-	Signal name	Input/ Output		
18 (GR)	15 (B)	Front buzzer drive signal	Input	[Ignition switch ON] • When the distance between the sensor and obstacle is approx 60 cm (23.62 in).	<b>NOTE:</b> • Voltage depends on volume. • Cycle depends on distance between sensor and obstacle.  <small>JSNIA5232GB</small>
19 (P)	15 (B)	Buzzer power supply	Output	[Ignition switch ON]	0 V
21 (BR)	14 (B)	Center sensor signal rear LH	Input	[Ignition switch ON]	 <small>JSNIA0837GB</small>
22 (W)	14 (B)	Corner sensor signal rear LH	Input	[Ignition switch ON]	 <small>JSNIA0837GB</small>

- \*1: With CAN gateway
- \*2: Without CAN gateway
- \*3: 2.0L turbo gasoline engine models
- \*4: VR30DDTT engine models

## Fail-Safe (Sonar Control Unit)

INFOID:000000013717487

The warning buzzer function is deactivated when a sensor system error is detected.

## DTC Inspection Priority Chart

INFOID:000000013717488

If multiple DTCs are detected simultaneously, check them one by one depending on the following DTC inspection priority chart.

Priority	Detected items (DTC)
1	<ul style="list-style-type: none"> <li>• U1000: CAN COMM CIRCUIT</li> <li>• U1010: CONTROL UNIT (CAN)</li> </ul>

# SONAR CONTROL UNIT

< ECU DIAGNOSIS INFORMATION >

[AROUND VIEW MONITOR SYSTEM]

Priority	Detected items (DTC)
2	B2724: SONAR CONTROL UNIT
3	<ul style="list-style-type: none"> <li>• B2720: CORNER SENSOR [RL]</li> <li>• B2721: CENTER SENSOR [RL]</li> <li>• B2722: CENTER SENSOR [RR]</li> <li>• B2723: CORNER SENSOR [RR]</li> <li>• B2729: CORNER SENSOR [FL]</li> <li>• B272A: CENTER SENSOR [FL]</li> <li>• B272B: CENTER SENSOR [FR]</li> <li>• B272C: CORNER SENSOR [FR]</li> <li>• B272D: FRONT BUZZER</li> </ul>

## DTC Index

INFOID:000000013717489

DTC	CONSULT display	Reference
B2720	CORNER SENSOR [RL]	<a href="#">AV-572, "DTC Description"</a>
B2721	CENTER SENSOR [RL]	<a href="#">AV-575, "DTC Description"</a>
B2722	CENTER SENSOR [RR]	<a href="#">AV-578, "DTC Description"</a>
B2723	CORNER SENSOR [RR]	<a href="#">AV-581, "DTC Description"</a>
B2724	SONAR CONTROL UNIT	<a href="#">AV-584, "DTC Description"</a>
B2729	CORNER SENSOR [FL]	<a href="#">AV-585, "DTC Description"</a>
B272A	CENTER SENSOR [FL]	<a href="#">AV-588, "DTC Description"</a>
B272B	CENTER SENSOR [FR]	<a href="#">AV-591, "DTC Description"</a>
B272C	CORNER SENSOR [FR]	<a href="#">AV-594, "DTC Description"</a>
B272D	FRONT BUZZER	<a href="#">AV-597, "DTC Description"</a>
U1000	CAN COMM CIRCUIT	<a href="#">AV-603, "SONAR CONTROL UNIT : DTC Description"</a>
U1010	CONTROL UNIT (CAN)	<a href="#">AV-605, "SONAR CONTROL UNIT : DTC Description"</a>

# AROUND VIEW MONITOR SYSTEM

< WIRING DIAGRAM >

[AROUND VIEW MONITOR SYSTEM]

## WIRING DIAGRAM

### AROUND VIEW MONITOR SYSTEM

#### Wiring Diagram

INFOID:0000000013717490

#### 2.0L TURBO GASOLINE ENGINE

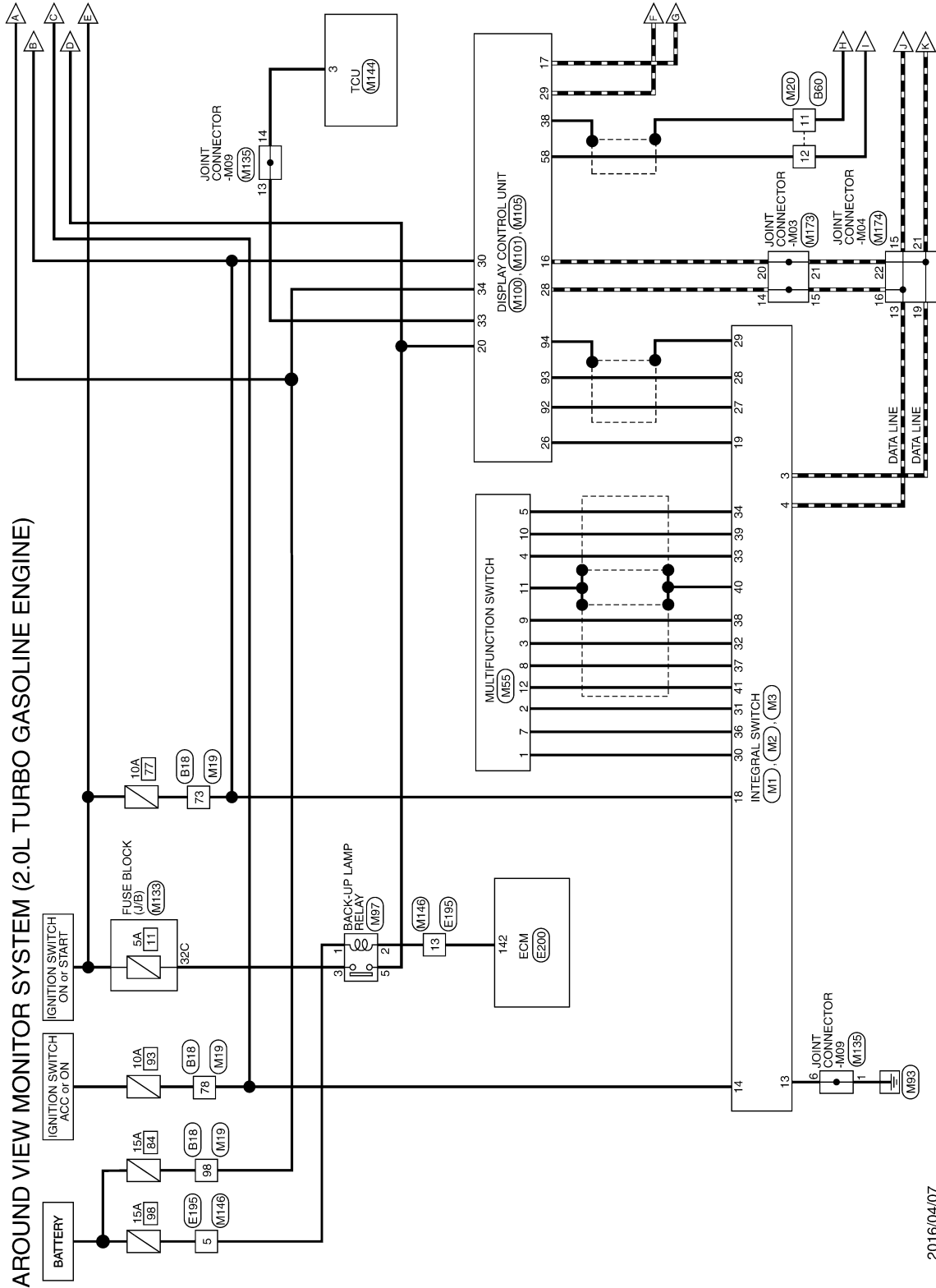

2016/04/07

JRNWF7531GB

A  
B  
C  
D  
E  
F  
G  
H  
I  
J  
K  
L  
M  
N  
O  
P

AV

# AROUND VIEW MONITOR SYSTEM

< WIRING DIAGRAM >

[AROUND VIEW MONITOR SYSTEM]

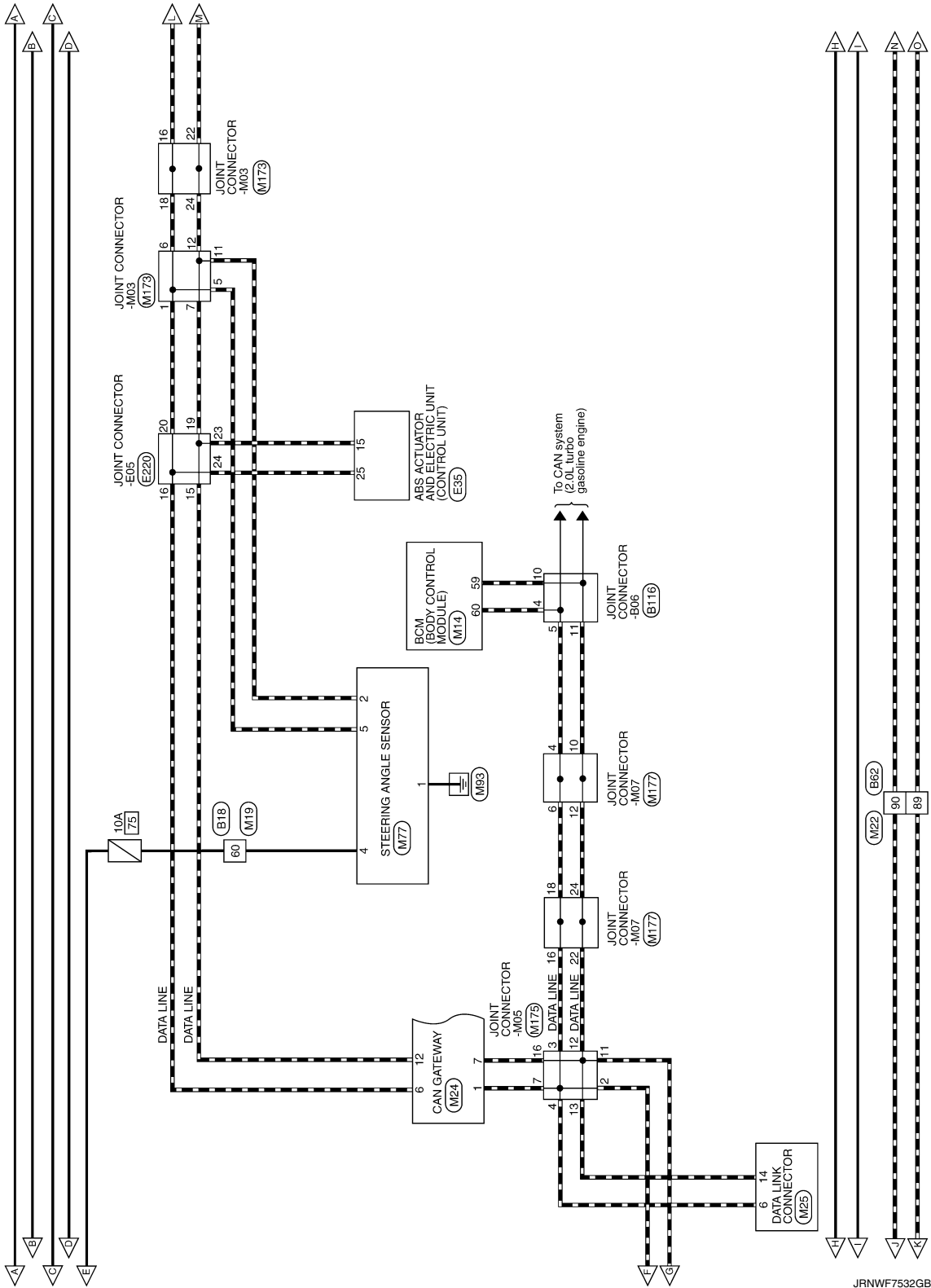

JRNWF7532GB

# AROUND VIEW MONITOR SYSTEM

## [AROUND VIEW MONITOR SYSTEM]

< WIRING DIAGRAM >

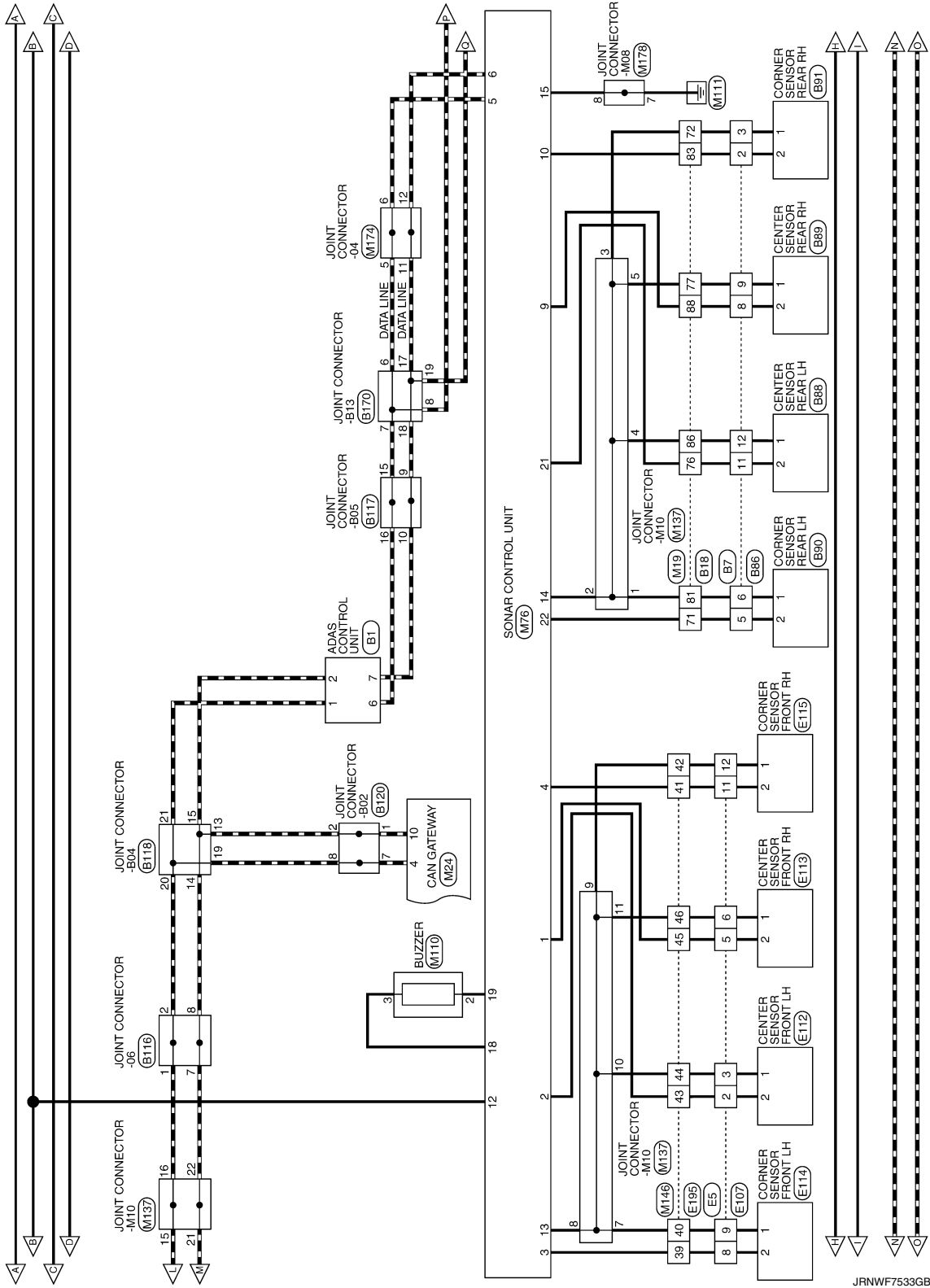

A  
B  
C  
D  
E  
F  
G  
H  
I  
J  
K  
L  
M  
N  
O  
P

AV

# AROUND VIEW MONITOR SYSTEM

[AROUND VIEW MONITOR SYSTEM]

< WIRING DIAGRAM >

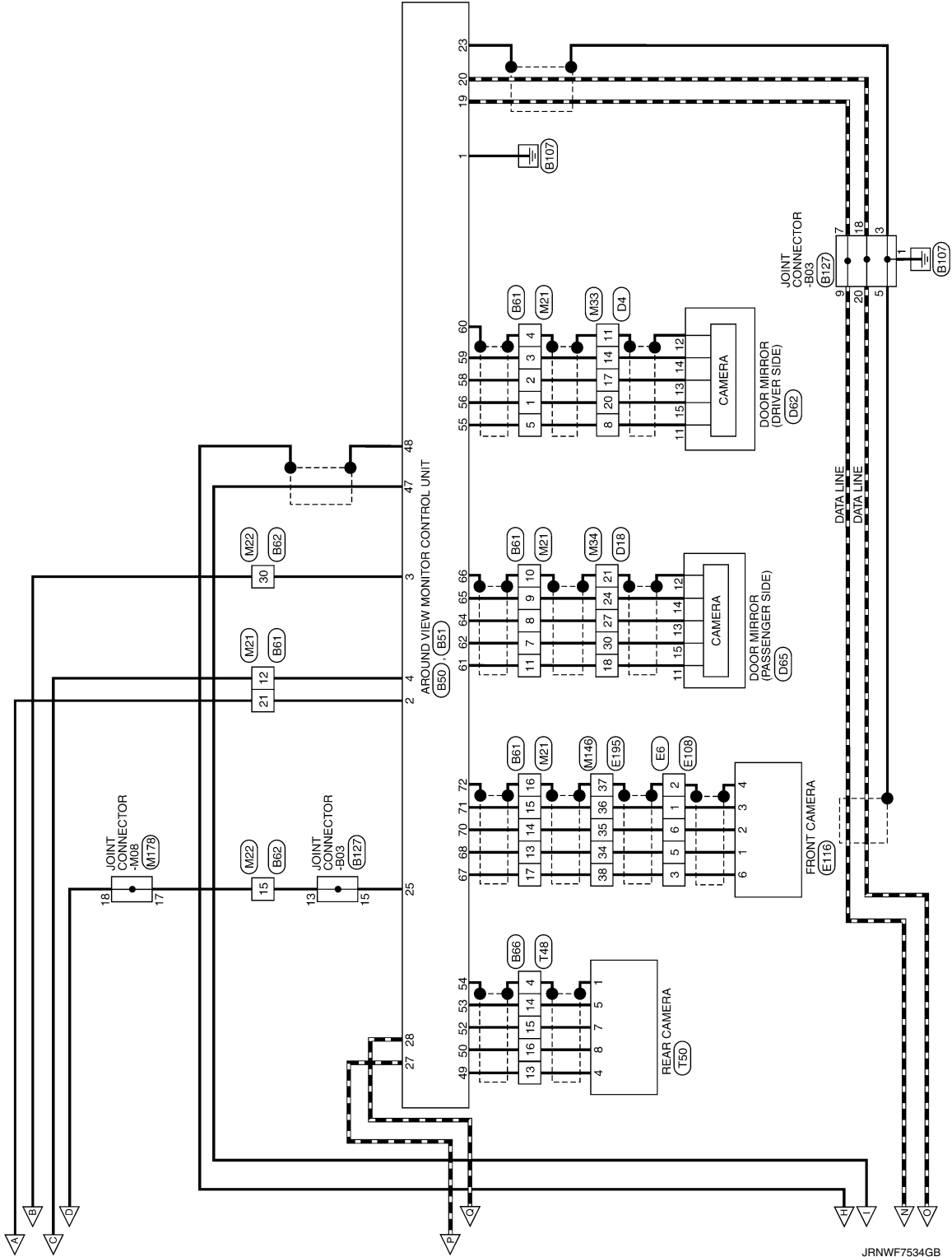

JRNWF7534GB

# AROUND VIEW MONITOR SYSTEM

## [AROUND VIEW MONITOR SYSTEM]

< WIRING DIAGRAM >

### AROUND VIEW MONITOR SYSTEM (2.0L TURBO GASOLINE ENGINE)

Connector No.	B1
Connector Name	ADAS CONTROL UNIT
Connector Type	TH24FW-AH



Connector No.	B18
Connector Name	WIRE TO WIRE
Connector Type	TH80FW-C31S-TM44

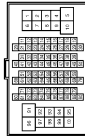

Terminal No.	Color Of Wire	Signal Name [Specification]
1	Y	-
2	G	-
3	L	-
5	Y	-
7	V	-
10	BG	-
11	BG	-
12	LG	-
13	GR	-
14	R	-
15	L	-
16	V	-
18	W	-
19	BR	-
20	W	-
22	R	-
23	V	-
24	R	- [With 2.0L turbo gasoline engine]
24	Y	- [With VR30 engine]
25	V	- [With 2.0L turbo gasoline engine]
25	W	- [With VR30 engine]
26	G	-
27	R	-
28	R	-
31	B	- [With VR30 engine]
31	BR	- [With 2.0L turbo gasoline engine]
32	B	-
33	B	-

Connector No.	B7
Connector Name	WIRE TO WIRE
Connector Type	TH12MW-AH

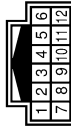

Terminal No.	Color Of Wire	Signal Name [Specification]
1	B	-
2	BG	-
3	B	-
4	R	-
5	W	-
6	B	-
7	R	-

34	LG	-
35	P	-
36	W	-
37	S8	-
38	LG	-
40	P	-
41	S8	-
42	BR	-
43	BG	-
44	BG	-
46	R	-
50	W	-
51	S8	-
52	V	-
53	LG	-
54	R	-
55	R	-
58	V	-
59	GR	-
60	G	-
61	G	-
62	BG	-
63	BR	-
64	Y	-
66	R	-
70	R	-
71	W	-
72	B	-
73	W	-
74	L	-
75	R	-
76	BR	-
77	B	-
78	S8	-
79	W	-
81	B	-
82	R	-
83	BG	-
84	L	-
85	R	-
86	B	-
88	G	-
89	V	-
91	GR	-
93	GR	-
94	GR	-
96	Y	-
98	BR	- [With VR30 engine and with BOSE system]
98	Y	- [Except with VR30 engine and with BOSE system]

Connector No.	B50
Connector Name	AROUND VIEW MONITOR CONTROL UNIT
Connector Type	TH40FW-AH



Terminal No.	Color Of Wire	Signal Name [Specification]
1	B	GROUND
2	Y	BATTERY POWER SUPPLY
3	LG	IGNITION SIGNAL
4	P	ACC POWER SUPPLY
19	P	AV COMMUNICATION SIGNAL [H]
20	LG	AV COMMUNICATION SIGNAL [L]
23	SHIELD	AV COMMUNICATION SIGNAL GROUND
25	BG	REVERSE SIGNAL
27	L	CAN-H
28	P	CAN-L [With ADAS]
28	R	CAN-L [Without ADAS]
29	SHIELD	CAN COMMUNICATION SIGNAL GROUND

Connector No.	B51
Connector Name	AROUND VIEW MONITOR CONTROL UNIT
Connector Type	TH32FW-AH



Terminal No.	Color Of Wire	Signal Name [Specification]
47	B	CAMERA IMAGE SIGNAL
48	SHIELD	CAMERA IMAGE SIGNAL GROUND
49	W	REAR CAMERA COMMUNICATION SIGNAL
50	B	REAR CAMERA POWER SUPPLY
52	R	REAR CAMERA GROUND
53	G	REAR CAMERA IMAGE SIGNAL (+)
54	SHIELD	REAR CAMERA IMAGE SIGNAL (-)

A  
B  
C  
D  
E  
F  
G  
H  
I  
J  
K  
L  
M  
N  
O  
P

AV

# AROUND VIEW MONITOR SYSTEM

## [AROUND VIEW MONITOR SYSTEM]

< WIRING DIAGRAM >

### AROUND VIEW MONITOR SYSTEM (2.0L TURBO GASOLINE ENGINE)

Terminal No.	Color Of Wire	Signal Name [Specification]
55	GR	SIDE CAMERA DRIVER SIDE COMMUNICATION SIGNAL
56	V	SIDE CAMERA DRIVER SIDE POWER SUPPLY
58	P	SIDE CAMERA DRIVER SIDE GROUND
59	LG	SIDE CAMERA DRIVER SIDE IMAGE SIGNAL (+)
60	SHIELD	SIDE CAMERA DRIVER SIDE IMAGE SIGNAL (-)
61	W	SIDE CAMERA PASSENGER SIDE COMMUNICATION SIGNAL
62	L	SIDE CAMERA PASSENGER SIDE POWER SUPPLY
64	R	SIDE CAMERA PASSENGER SIDE GROUND
65	G	SIDE CAMERA PASSENGER SIDE IMAGE SIGNAL (+)
66	SHIELD	SIDE CAMERA PASSENGER SIDE IMAGE SIGNAL (-)
67	B	FRONT CAMERA COMMUNICATION SIGNAL
68	W	FRONT CAMERA POWER SUPPLY
70	G	FRONT CAMERA GROUND
71	R	FRONT CAMERA IMAGE SIGNAL (+)
72	J SHIELD	FRONT CAMERA IMAGE SIGNAL (-)

Connector No.	Wire To Wire
B60	WIRE TO WIRE
TH16FW-NH	

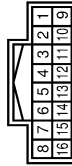

Terminal No.	Color Of Wire	Signal Name [Specification]
7	R	
8	L	
10	Y	
11	SHIELD	
12	B	
13	W	
14	R	

Connector No.	Wire To Wire
B61	WIRE TO WIRE
TH24FW-AH	

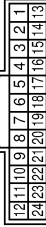

Terminal No.	Color Of Wire	Signal Name [Specification]
1	V	
2	P	
3	LG	
4	SHIELD	
5	GR	
7	L	
8	R	
9	G	
10	SHIELD	
11	W	
12	Y	
13	R	
14	BG	
15	BG	
16	G	
17	B	
21	Y	

Connector No.	Wire To Wire
B62	WIRE TO WIRE
TH80FW-CS16-1M4	

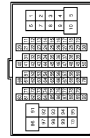

Terminal No.	Color Of Wire	Signal Name [Specification]
1	BR	
1	LG	
1	W	

Terminal No.	Color Of Wire	Signal Name [Specification]
35	LG	
35	W	
36	R	
37	P	
37	W	
38	L	
38	W	
39	P	
39	R	
40	W	
40	G	
41	L	
42	R	
43	SHIELD	
44	P	
45	B	
45	G	
46	SHIELD	
47	G	
48	BG	
48	SB	
49	G	
51	GR	
51	L	
52	W	
52	Y	
53	R	
54	GR	
55	L	
56	V	
57	R	
58	LG	
59	P	
60	BR	
61	L	
61	R	
62	P	
62	V	
63	L	
64	W	
65	R	
66	L	
66	LG	
67	G	
68	L	
69	P	
71	R	
71	GR	
72	G	

Terminal No.	Color Of Wire	Signal Name [Specification]
2	L	
2	SHIELD	
3	BR	
3	R	
3	W	
4	SHIELD	
4	Y	
5	V	
6	BG	
6	BR	
7	B	
7	BR	
7	W	
7	Y	
8	B	
8	G	
8	Y	
9	LG	
9	SHIELD	
10	V	
11	GR	
12	Y	
13	R	
14	BG	
15	BG	
15	GR	
16	V	
17	P	
18	L	
19	G	
20	GR	
21	R	
23	W	
24	BG	
24	V	
25	SB	
25	G	
26	W	
27	R	
28	R	
29	LG	
30	LG	
30	P	
31	SHIELD	
32	L	
33	B	
33	LG	
34	SHIELD	

# AROUND VIEW MONITOR SYSTEM

## [AROUND VIEW MONITOR SYSTEM]

< WIRING DIAGRAM >

### AROUND VIEW MONITOR SYSTEM (2.0L TURBO GASOLINE ENGINE)

72	Y	- [With 2.0L turbo gasoline engine]
73	R	- [With 2.0L turbo gasoline engine]
73	SHIELD	- [With VR30 engine]
74	BG	- [With 2.0L turbo gasoline engine]
74	L	- [With VR30 engine]
75	GR	- [With 2.0L turbo gasoline engine]
75	V	- [With VR30 engine]
76	GR	- [With VR30 engine]
76	V	- [With VR30 engine]
77	P	- [With 2.0L turbo gasoline engine]
78	L	-
79	G	-
80	GR	- [With 2.0L turbo gasoline engine]
80	W	- [With VR30 engine]
81	B	- [With VR30 engine]
81	R	- [With 2.0L turbo gasoline engine]
82	G	- [With 2.0L turbo gasoline engine]
82	SHIELD	- [With VR30 engine]
83	R	- [With 2.0L turbo gasoline engine]
83	W	- [With VR30 engine]
84	BR	- [With 2.0L turbo gasoline engine]
84	SHIELD	- [With VR30 engine]
85	BG	- [With VR30 engine]
85	G	- [With 2.0L turbo gasoline engine]
86	R	-
87	LG	- [With VR30 engine]
87	SHIELD	- [With 2.0L turbo gasoline engine]
88	R	-
89	LG	-
90	P	-
92	L	- [With 2.0L turbo gasoline engine]
92	W	- [With VR30 engine]
93	SHIELD	-
94	R	-
95	L	- [With 2.0L turbo gasoline engine]
95	Y	- [With VR30 engine]
96	W	-
97	L	- [With VR30 engine]
97	R	- [With 2.0L turbo gasoline engine and with BSE system]
97	W	- [With 2.0L turbo gasoline engine and with BSE system]
99	BR	- [With VR30 engine and with BSE system]
99	P	- [With 2.0L turbo gasoline engine]
99	Y	- [With VR30 engine and without BSE system]
100	BR	- [With VR30 engine]
100	W	- [With 2.0L turbo gasoline engine]

Connector No.	B86
Connector Name	WIRE TO WIRE
Connector Type	NS15AWW-CS



4	R	-
5	W	-
6	B	-
7	R	-
8	G	-
9	B	-
10	GR	-
11	BR	-
12	B	-

Terminal No.	Color Of Wire	Signal Name [Specification]
1	R	-
2	BG	-
4	SHIELD	-
5	W	-
6	GR	-
8	B	-
9	R	-
10	P	-
11	B	-
13	SHIELD	- [With rear view monitor]
13	W	- [With around view monitor]
14	B	- [With rear view monitor]
14	G	- [With around view monitor]
15	R	- [With around view monitor]
15	W	- [With rear view monitor]
16	B	- [With around view monitor]
16	R	- [With rear view monitor]

Connector No.	B86
Connector Name	WIRE TO WIRE
Connector Type	TH12FM-NH



Terminal No.	Color Of Wire	Signal Name [Specification]
1	B	-
2	BG	-
3	B	-

Connector No.	B90
Connector Name	CORNER SENSOR REAR LH
Connector Type	RH03FB



Terminal No.	Color Of Wire	Signal Name [Specification]
1	B	-
2	W	-

Connector No.	B91
Connector Name	CORNER SENSOR REAR RH
Connector Type	RH03FB



Terminal No.	Color Of Wire	Signal Name [Specification]
1	B	-
2	BG	-

Connector No.	B88
Connector Name	CENTER SENSOR REAR LH
Connector Type	RH03FB



Terminal No.	Color Of Wire	Signal Name [Specification]
1	B	-
2	BR	-

Connector No.	B89
Connector Name	CENTER SENSOR REAR RH
Connector Type	RH03FB



Terminal No.	Color Of Wire	Signal Name [Specification]
1	B	-
2	G	-

A  
B  
C  
D  
E  
F  
G  
H  
I  
J  
K  
L  
M  
N  
O  
P

AV

# AROUND VIEW MONITOR SYSTEM

## [AROUND VIEW MONITOR SYSTEM]

< WIRING DIAGRAM >

### AROUND VIEW MONITOR SYSTEM (2.0L TURBO GASOLINE ENGINE)

Connector No.	B116
Connector Name	JOINT CONNECTOR-B06
Connector Type	24342_4GAZA



6	5	4	3	2	1
12	11	10	9	8	7
18	17	16	15	14	13
24	23	22	21	20	19

Terminal No.	Color Of Wire	Signal Name [Specification]
1	L	-
2	L	-
3	L	-
4	L	-
5	L	-
6	L	-
7	R	-
8	R	- [Without Gateway]
9	V	- [Without Gateway]
10	V	- [Without Gateway]
11	V	-
12	P	- [Without Gateway]
13	P	- [Without Gateway]
14	R	- [Without Gateway]
15	R	- [Without Gateway]
16	L	- [Without Gateway]
17	L	- [Without Gateway]
18	L	- [Without Gateway]
19	SHIELD	- [Without Gateway]
20	SHIELD	- [Without Gateway]
21	L	- [Without Gateway]
22	L	- [Without Gateway]
23	R	- [Without Gateway]
24	R	- [Without Gateway]

Connector No.	B117
Connector Name	JOINT CONNECTOR-B05
Connector Type	24342_4GAZA



6	5	4	3	2	1
12	11	10	9	8	7
18	17	16	15	14	13
24	23	22	21	20	19

Terminal No.	Color Of Wire	Signal Name [Specification]
1	B	-
2	B	- [With 2.0L turbo gasoline engine]
3	SHIELD	- [With VR30 engine]
4	B	-
5	SHIELD	- [With VR30 engine]
6	B	-
7	P	-
8	P	-
9	P	-
10	P	-
11	P	-
12	P	-
13	L	-
14	L	-
15	L	-
16	L	-
17	L	-
18	L	-
19	SHIELD	-
20	SHIELD	-
21	SHIELD	-
22	SHIELD	-
23	SHIELD	-
24	SHIELD	-

Connector No.	B118
Connector Name	JOINT CONNECTOR-B04
Connector Type	24342_4GAZA



6	5	4	3	2	1
12	11	10	9	8	7
18	17	16	15	14	13
24	23	22	21	20	19

Terminal No.	Color Of Wire	Signal Name [Specification]
1	LG	- [With VR30 engine]
2	LG	- [With 2.0L turbo gasoline engine]
3	SHIELD	- [With VR30 engine]
4	LG	- [With 2.0L turbo gasoline engine]
5	LG	- [With VR30 engine]
6	LG	- [With 2.0L turbo gasoline engine]
7	LG	- [With 2.0L turbo gasoline engine]
8	R	-
9	LG	- [With 2.0L turbo gasoline engine]
10	LG	- [With VR30 engine]
11	SHIELD	- [With 2.0L turbo gasoline engine]
12	SHIELD	- [With VR30 engine]
13	L	- [With VR30 engine]
14	R	- [With 2.0L turbo gasoline engine]
15	R	- [With 2.0L turbo gasoline engine]
16	L	- [With VR30 engine]
17	L	- [With VR30 engine]
18	L	- [With 2.0L turbo gasoline engine]
19	R	- [With VR30 engine]
20	L	- [With 2.0L turbo gasoline engine]
21	L	-
22	L	-
23	L	-
24	SHIELD	- [With 2.0L turbo gasoline engine]

21	L	- [With 2.0L turbo gasoline engine]
22	SHIELD	- [With VR30 engine]
23	R	-
24	R	-

Connector No.	B120
Connector Name	JOINT CONNECTOR-B02
Connector Type	24342_4GAZA



6	5	4	3	2	1
12	11	10	9	8	7
18	17	16	15	14	13
24	23	22	21	20	19

Terminal No.	Color Of Wire	Signal Name [Specification]
1	R	-
2	R	-
3	L	- [With VR30 engine]
4	R	- [With 2.0L turbo gasoline engine]
5	R	- [With VR30 engine]
6	L	- [With 2.0L turbo gasoline engine]
7	L	-
8	L	-
9	L	- [With 2.0L turbo gasoline engine]
10	R	- [With VR30 engine]
11	L	- [With 2.0L turbo gasoline engine]
12	R	- [With VR30 engine]
13	W	-
14	W	-
15	W	-
17	SHIELD	-
18	B	-
19	B	- [With 2.0L turbo gasoline engine]
20	GR	- [With VR30 engine]
21	SHIELD	- [With 2.0L turbo gasoline engine]
22	GR	- [With VR30 engine]
23	W	-

# AROUND VIEW MONITOR SYSTEM

< WIRING DIAGRAM >

[AROUND VIEW MONITOR SYSTEM]

## AROUND VIEW MONITOR SYSTEM (2.0L TURBO GASOLINE ENGINE)

24	W	-
Connector No.	B127	
Connector Name	JOINT CONNECTOR-B03	
Connector Type	NH20FG-DC	

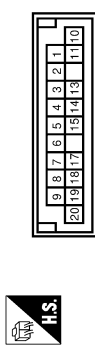

Terminal No.	Color Of Wire	Signal Name [Specification]
1	B	-
2	SHIELD	-
3	SHIELD	-
4	SHIELD	-
5	SHIELD	-
6	P	-
7	P	-
8	P	-
9	P	-
10	LG	-
11	LG	-
12	LG	-
13	BG	-
14	BG	-
15	BG	-
17	LG	-
18	LG	-
19	LG	-
20	LG	-

Connector No.	B170	
Connector Name	JOINT CONNECTOR-B13	
Connector Type	NH20FG-DC	

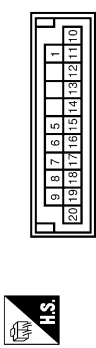

Terminal No.	Color Of Wire	Signal Name [Specification]
1	SHIELD	-
5	SHIELD	-
6	L	-
7	L	-
8	L	-
9	L	-
10	SHIELD	-
11	SHIELD	-
12	SHIELD	-
13	SHIELD	-
14	SHIELD	-
15	SHIELD	-
16	SHIELD	-
17	P	-
18	P	-
19	P	-
20	P	-

Connector No.	D4	
Connector Name	WIRE TO WIRE	
Connector Type	NH60FW-TS12	

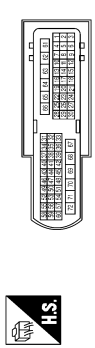

Terminal No.	Color Of Wire	Signal Name [Specification]
6	V	-
8	G	-
9	GR	-

10	Y	-
11	SHIELD	-
12	BG	-
13	L	-
14	B	-
15	Y	-
16	GR	-
17	R	-
18	GR	-
19	R	-
20	W	-
21	LG	-
22	W	-
23	L	-
24	G	-
25	BR	-
27	BR	-
28	V	-
29	B	-
30	W	-
31	P	-
32	Y	-
33	BR	-
34	L	-
35	R	-
36	GR	-
37	G	-
38	R	-
39	B	-
40	LG	-
41	L	-
43	BG	-
44	Y	-
46	W	-
47	R	-
49	BR	-
50	B	-
52	V	-
53	GR	-
54	R	-
55	S8	-
56	BR	-
57	R	-
58	L	-
59	V	-
60	G	-
61	BG	-
62	Y	-
63	S8	-
64	B	-

65	Y	-
66	BR	-
68	Y	-
69	L	-
70	W	-
71	LG	-
72	P	-

Connector No.	D18	
Connector Name	WIRE TO WIRE	
Connector Type	NH60FW-TS12	

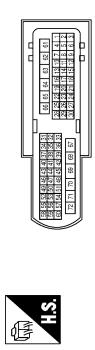

Terminal No.	Color Of Wire	Signal Name [Specification]
1	GR	-
2	P	-
5	BR	-
6	Y	-
8	W	-
9	L	-
10	L	-
11	GR	-
13	Y	-
16	R	-
17	B	-
18	W	-
19	B	-
20	G	-
21	SHIELD	-
22	GR	-
23	BG	-
24	B	-
25	BR	-
26	V	-
27	G	-
28	V	-
29	Y	-
30	R	-
38	R	-
39	B	-
49	LG	-

A  
B  
C  
D  
E  
F  
G  
H  
I  
J  
K  
L  
M  
AV  
O  
P

# AROUND VIEW MONITOR SYSTEM

## [AROUND VIEW MONITOR SYSTEM]

< WIRING DIAGRAM >

### AROUND VIEW MONITOR SYSTEM (2.0L TURBO GASOLINE ENGINE)

Connector No.	Color Of Wire	Signal Name [Specification]
51	R	-
52	P	-
55	L	-
56	Y	-
58	SB	-
59	R	-
60	G	-
63	B	-
64	Y	-
65	BR	-
66	GR	-
69	W	-
70	L	-
71	BG	-
72	Y	-

Connector No.	Color Of Wire	Signal Name [Specification]
D62	-	-
DOOR MIRROR (DRIVER SIDE)		
RH10MB	-	-



Terminal No.	Color Of Wire	Signal Name [Specification]
11	G	-
12	SHIELD	-
13	R	-
14	B	-
15	W	-
16	V	-
17	BR	-
18	LG	-
19	W	-
20	G	-

Connector No.	Color Of Wire	Signal Name [Specification]
D65	-	-
DOOR MIRROR (PASSENGER SIDE)		
RH10MB	-	-



Terminal No.	Color Of Wire	Signal Name [Specification]
11	W	-
12	SHIELD	-
13	G	-
14	B	-
15	R	-
16	Y	-
17	P	-
18	BR	-
19	W	-
20	GR	-

Connector No.	Color Of Wire	Signal Name [Specification]
E5	-	-
WIRE TO WIRE		
RH12MB	-	-

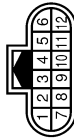

Terminal No.	Color Of Wire	Signal Name [Specification]
2	BR	-
3	P	-
4	GR	-
5	SB	-
6	Y	-
8	L	-
9	GR	-
10	B	-
11	W	-
12	B	-

Connector No.	Color Of Wire	Signal Name [Specification]
EG	-	-
WIRE TO WIRE		
RS6GMB	-	-



Terminal No.	Color Of Wire	Signal Name [Specification]
1	G	-
2	SHIELD	-
3	R	-
5	W	-
6	B	-

Connector No.	Color Of Wire	Signal Name [Specification]
E35	-	-
ABS ACTUATOR AND ELECTRICAL UNIT (CONTROL UNIT)		
SA230FB-SJ24-UJ	-	-

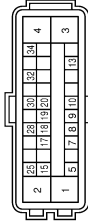

Terminal No.	Color Of Wire	Signal Name [Specification]
1	B	-
2	G	-
3	G	-
4	P	-
5	LG	-
7	V	-
8	GR	-
9	BR	-
10	GR	-
13	R	-
15	P	-
16	R	-
17	Y	-

Connector No.	Color Of Wire	Signal Name [Specification]
18	LG	-
19	V	-
20	BG	-
25	L	-
28	G	-
30	R	-
32	SHIELD	-
34	G	-

Connector No.	Color Of Wire	Signal Name [Specification]
E107	-	-
WIRE TO WIRE		
RH12FB	-	-

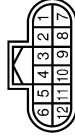

Terminal No.	Color Of Wire	Signal Name [Specification]
1	L	-
2	BR	-
3	P	-
4	GR	-
5	SB	-
6	Y	-
7	L	-
8	L	-
9	GR	-
10	B	-
11	W	-
12	B	-

JRNWF7540GB

# AROUND VIEW MONITOR SYSTEM

## [AROUND VIEW MONITOR SYSTEM]

< WIRING DIAGRAM >

### AROUND VIEW MONITOR SYSTEM (2.0L TURBO GASOLINE ENGINE)

Connector No.	E108
Connector Name	WIRE TO WIRE
Connector Type	RS06FBPR



Connector No.	E113
Connector Name	CENTER SENSOR FRONT RH
Connector Type	RH03FB



Connector No.	E115
Connector Name	CORNER SENSOR FRONT RH
Connector Type	RH03FB



Connector No.	E195
Connector Name	WIRE TO WIRE
Connector Type	TK36FWAS10

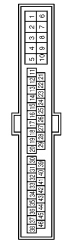

Terminal No.	Color Of Wire	Signal Name [Specification]
1	G	-
2	SHIELD	-
3	W	-
5	R	-
6	B	-

Connector No.	E112
Connector Name	CENTER SENSOR FRONT LH
Connector Type	RH03FB



Terminal No.	Color Of Wire	Signal Name [Specification]
1	Y	-
2	SB	-

Connector No.	E114
Connector Name	CORNER SENSOR FRONT LH
Connector Type	RH03FB



Terminal No.	Color Of Wire	Signal Name [Specification]
1	B	-
2	W	-

Connector No.	E116
Connector Name	FRONT CAMERA
Connector Type	RH06MB



Terminal No.	Color Of Wire	Signal Name [Specification]
1	GR	-
2	L	-

Terminal No.	Color Of Wire	Signal Name [Specification]
1	R	-
2	B	-
3	G	-
4	SHIELD	-
6	W	-

Terminal No.	Color Of Wire	Signal Name [Specification]
5	BR	-
8	GR	-
9	P	-
10	R	-
11	L	-
12	P	-
13	GR	-
14	Y	-
15	G	-
16	W	-
17	L	-
18	R	-
19	BR	-
20	SHIELD	-
21	BR	-
22	V	-
23	W	-
24	L	-
25	G	-
26	G	-
30	Y	-
31	GR	-
32	SR	-
33	W	-
34	W	-
35	B	-
36	G	-
37	SHIELD	-
38	R	-
39	L	-
40	GR	-
41	W	-
42	B	-
43	BR	-
44	P	-
45	SB	-

A  
B  
C  
D  
E  
F  
G  
H  
I  
J  
K  
L  
M  
AV  
O  
P

# AROUND VIEW MONITOR SYSTEM

## [AROUND VIEW MONITOR SYSTEM]

< WIRING DIAGRAM >

### AROUND VIEW MONITOR SYSTEM (2.0L TURBO GASOLINE ENGINE)

46	Y	-
Connector No.	E200	
Connector Name	ECM	
Connector Type	ADAS2FB-AH26	



Terminal No.	Color Of Wire	Signal Name [Specification]
97	G	POWER SUPPLY (MAIN)
98	B	ECM GROUND
99	G	POWER SUPPLY (MAIN)
100	B	ECM GROUND
101	G	POWER SUPPLY (MAIN)
102	B	ECM GROUND
103	V	COOLING FAN CONTROL SIGNAL (PWM)
104	Y	SENSOR POWER SUPPLY
105	R	SENSOR POWER SUPPLY
106	W	SENSOR GROUND
109	P	ENGINE SPEED SIGNAL
111	G	POWER SUPPLY
116	LG	STARTER RELAY-L
119	BR	SENSOR GROUND
120	BG	SENSOR GROUND
123	BR	MAIN RELAY CONTROL SIGNAL
127	V	FUEL PUMP ON SIGNAL
132	G	ACCELERATOR PEDAL POSITION SENSOR 1
137	L	CAN-H
138	L	DRIVETRAIN CAN-H
143	GR	BACK-UP LAMP SWITCH
143	LG	REFRIGERANT PRESSURE SENSOR
145	L	ACCELERATOR PEDAL POSITION SENSOR 2
146	L	FUEL TANK PRESSURE SENSOR
148	L	THROTTLE CONTROL MOTOR (CLOSE) (BANK 2)
150	P	CAN-L
151	P	DRIVETRAIN CAN-L
152	B	EVAP-CANISTER VENT CONTROL VALVE
153	G	EVAP-PURGE CONTROL VALVE

Connector No.	E220	
Connector Name	JOINT CONNECTOR-E05	
Connector Type	NH24FB-J	

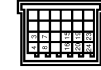

Terminal No.	Color Of Wire	Signal Name [Specification]
3	W	-
4	L	-
7	W	-
8	L	-
15	R	-
16	L	-
19	R	-
20	L	-
23	R	-
24	L	-

Connector No.	M1	
Connector Name	INTEGRAL SWITCH	
Connector Type	TH24FW-AH	

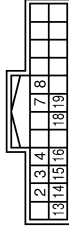

Terminal No.	Color Of Wire	Signal Name [Specification]
2	R	ILLUMINATION SIGNAL
3	LG	AV COMMUNICATION SIGNAL (L)
4	SB	AV COMMUNICATION SIGNAL (H)
7	W/B	DISK EJECT SIGNAL
8	G	HAZARD SIGNAL
13	B	GROUND
14	SB	ACC-POWER SUPPLY (With 2.0L turbo gasoline engine)
14	V	ACC-POWER SUPPLY (With VRE30 engine)
15	B	ILLUMINATION CONTROL SIGNAL
16	BG	DISK EJECT SIGNAL GROUND

18	R	IGNITION SIGNAL (With VRE30 engine)
18	W	IGNITION SIGNAL (With 2.0L turbo gasoline engine)
19	BR	CAMERA SWITCH SIGNAL

Connector No.	M2	
Connector Name	INTEGRAL SWITCH	
Connector Type	Typec-1554987-6	



Terminal No.	Color Of Wire	Signal Name [Specification]
27	W	LVDS (+)
28	B	LVDS (-)
29	SHIELD	SHIELD

Connector No.	M3	
Connector Name	INTEGRAL SWITCH	
Connector Type	TH12FW-AH	



Terminal No.	Color Of Wire	Signal Name [Specification]
30	BR	ILLUMINATION SIGNAL (MULTIFUNCTION SWITCH)
31	W	GROUND (MULTIFUNCTION SWITCH)
32	R	END-C-B SIGNAL
33	R	PUSH SWITCH A SIGNAL
34	W	PUSH SWITCH C SIGNAL
36	V	ILLUMINATION CONTROL SIGNAL (MULTIFUNCTION SWITCH)
37	W	END-C-A SIGNAL
38	G	SELECT SWITCH SIGNAL
39	B	PUSH SWITCH B SIGNAL
40	B	SHIELD
41	L	L/R DETECTION SIGNAL

Connector No.	M14	
Connector Name	BCM (BODY CONTROL MODULE)	
Connector Type	TH40FB-AH	



Terminal No.	Color Of Wire	Signal Name [Specification]
48	R	PUSH-BTN IGN SW (L/PWR)
52	G	DONGLE LINK
54	V	COMM LINE
55	R	RAIN SENSOR
59	P	CAN-L
60	L	CAN-H
61	G	REAR WINDOW DEF RLY CONT
62	R	STARTER RLY CONT
64	V	I-KEY WARN BUZZER
65	B	OUTS HD LAMP CONT
66	B	BLOWER FAN RLY CONT (With VRE30 engine)
66	Y	BLOWER FAN RLY CONT (With 2.0L turbo gasoline engine)
67	W/B	IGN RLYAY (F/B) CONT
68	R	DIMMER
69	GR	A/T SHFT SELECT PWR SPLY
70	B	IGN RLYAY (PDM E/R) CONT
71	G	DR DOOR REQ SW
72	SR	PASS DOOR REQ SW
75	BR	COMBI SW INPAUT 5
76	BG	COMBI SW INPAUT 4
77	V	COMBI SW INPAUT 3
78	Y	COMBI SW INPAUT 2
79	LG	COMBI SW INPAUT 1
80	L	TR LID OPNR SW

# AROUND VIEW MONITOR SYSTEM

## [AROUND VIEW MONITOR SYSTEM]

< WIRING DIAGRAM >

### AROUND VIEW MONITOR SYSTEM (2.0L TURBO GASOLINE ENGINE)

Connector No.	M13
Connector Name	WIRE TO WIRE
Connector Type	TH80MW-CS16-TM4

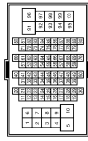

Terminal No.	Color Of Wire	Signal Name [Specification]
1	Y	-
2	G	-
3	SB	-
5	Y	-
7	W	-
10	BG	-
11	BR	-
12	LG	-
13	GR	-
14	R	-
15	L	-
16	V	-
18	W	-
19	BR	-
20	W	-
24	R	- [With 2.0L turbo gasoline engine]
24	Y	- [With VR30 engine]
25	P	- [With 2.0L turbo gasoline engine]
25	W	- [With VR30 engine]
26	G	-
27	R	-
28	R	-
31	BR	-
32	B	-
33	B	-
34	P	-
35	W	-
36	W	-
37	SB	-
38	LG	-
40	P	-
41	G	-
42	BR	-
43	BR	-
44	BR	-
46	BG	-

50	W	-
51	Y	-
52	V	-
53	LG	-
54	R	-
55	R	-
58	V	-
59	BG	-
60	G	-
61	G	-
62	BG	-
63	BR	-
64	Y	-
66	R	-
70	LG	-
71	W	-
72	B	-
73	W	-
74	L	-
75	W	-
76	BR	-
77	B	-
78	SB	-
79	W	-
81	B	-
82	R	-
83	BG	-
84	L	-
85	W	-
86	B	-
88	G	-
89	V	-
91	GR	-
93	GR	-
94	GR	-
96	W	-
98	BR	- [With VR30 engine and with ROSE system]
98	Y	- [Except with VR30 engine and with ROSE system]

Connector No.	M20
Connector Name	WIRE TO WIRE
Connector Type	TH16AW-NH

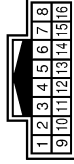

Terminal No.	Color Of Wire	Signal Name [Specification]
7	W	-
8	L	-
10	Y	-
11	SHIELD	-
12	B	-
13	W	-
14	R	-

Connector No.	M21
Connector Name	WIRE TO WIRE
Connector Type	TH24MW-NH



Terminal No.	Color Of Wire	Signal Name [Specification]
1	V	-
2	P	-
3	LG	-
4	SHIELD	-
5	GR	-
7	L	-
8	R	-
9	G	-
10	SHIELD	-
11	W	-
12	Y	-
13	LG	-
14	LG	-
15	BR	- [With 2.0L turbo gasoline engine]
15	P	- [With VR30 engine]
16	SB	- [Without DCM]
17	Y	-
18	L	-
19	G	-
20	GR	-

15	R	-
16	SHIELD	-
17	B	-
21	Y	-

Connector No.	M22
Connector Name	WIRE TO WIRE
Connector Type	TH80MW-CS16-TM4



Terminal No.	Color Of Wire	Signal Name [Specification]
1	LG	-
2	L	- [With VR30 engine]
2	SHIELD	- [With 2.0L turbo gasoline engine]
3	BR	- [With 2.0L turbo gasoline engine]
3	R	- [With VR30 engine]
4	SHIELD	- [With VR30 engine]
4	Y	- [With 2.0L turbo gasoline engine]
5	G	- [With VR30 engine]
5	V	- [With 2.0L turbo gasoline engine]
6	BG	- [With VR30 engine]
6	BR	- [With 2.0L turbo gasoline engine]
7	LG	- [With VR30 engine]
7	P	- [With 2.0L turbo gasoline engine]
8	G	- [With 2.0L turbo gasoline engine]
8	P	- [With VR30 engine]
9	LG	- [With 2.0L turbo gasoline engine]
9	SHIELD	- [With VR30 engine]
10	V	-
11	GR	-
12	V	-
13	LG	-
14	LG	-
15	BR	- [With 2.0L turbo gasoline engine]
15	P	- [With VR30 engine]
16	V	- [Without DCM]
17	Y	-
18	L	-
19	G	-
20	GR	-

A  
B  
C  
D  
E  
F  
G  
H  
I  
J  
K  
L  
M  
AV  
O  
P

# AROUND VIEW MONITOR SYSTEM

## [AROUND VIEW MONITOR SYSTEM]

< WIRING DIAGRAM >

### AROUND VIEW MONITOR SYSTEM (2.0L TURBO GASOLINE ENGINE)

21	R	-	-	-	-
23	L	-	-	-	-
24	BG	-	-	-	-
24	V	-	-	-	-
25	L	-	-	-	-
25	SB	-	-	-	-
26	G	-	-	-	-
26	W	-	-	-	-
27	R	-	-	-	-
28	R	-	-	-	-
29	LG	-	-	-	-
30	SB	-	-	-	-
30	W	-	-	-	-
31	SHIELD	-	-	-	-
32	L	-	-	-	-
33	B	-	-	-	-
33	LG	-	-	-	-
34	SHIELD	-	-	-	-
35	LG	-	-	-	-
35	W	-	-	-	-
36	R	-	-	-	-
37	R	-	-	-	-
38	L	-	-	-	-
38	W	-	-	-	-
39	P	-	-	-	-
39	R	-	-	-	-
39	V	-	-	-	-
40	G	-	-	-	-
41	L	-	-	-	-
42	R	-	-	-	-
43	SHIELD	-	-	-	-
44	P	-	-	-	-
45	B	-	-	-	-
45	G	-	-	-	-
46	SHIELD	-	-	-	-
47	G	-	-	-	-
48	BG	-	-	-	-
48	BR	-	-	-	-
48	SB	-	-	-	-
49	G	-	-	-	-
51	L	-	-	-	-
51	V	-	-	-	-
52	L	-	-	-	-
52	Y	-	-	-	-
53	R	-	-	-	-
54	GR	-	-	-	-
55	L	-	-	-	-
56	P	-	-	-	-
57	R	-	-	-	-

58	LG	-	-	-	-
59	SB	-	-	-	-
60	BR	-	-	-	-
61	R	-	-	-	-
62	P	-	-	-	-
62	V	-	-	-	-
63	L	-	-	-	-
64	W	-	-	-	-
65	R	-	-	-	-
66	L	-	-	-	-
66	R	-	-	-	-
67	G	-	-	-	-
68	L	-	-	-	-
69	P	-	-	-	-
71	GR	-	-	-	-
71	R	-	-	-	-
72	G	-	-	-	-
72	V	-	-	-	-
73	LG	-	-	-	-
73	SHIELD	-	-	-	-
74	L	-	-	-	-
74	LG	-	-	-	-
75	P	-	-	-	-
76	SB	-	-	-	-
76	V	-	-	-	-
77	Y	-	-	-	-
78	L	-	-	-	-
79	G	-	-	-	-
80	GR	-	-	-	-
80	W	-	-	-	-
81	B	-	-	-	-
81	R	-	-	-	-
82	G	-	-	-	-
82	SHIELD	-	-	-	-
83	R	-	-	-	-
83	W	-	-	-	-
84	BR	-	-	-	-
84	SHIELD	-	-	-	-
85	BR	-	-	-	-
85	G	-	-	-	-
86	R	-	-	-	-
87	LG	-	-	-	-
87	SHIELD	-	-	-	-
88	R	-	-	-	-
89	LG	-	-	-	-
90	SB	-	-	-	-
92	L	-	-	-	-
92	W	-	-	-	-
93	SHIELD	-	-	-	-

94	R	-	-	-	-
95	L	-	-	-	-
95	Y	-	-	-	-
96	W	-	-	-	-
97	L	-	-	-	-
97	RR	-	-	-	-
99	P	-	-	-	-
99	V	-	-	-	-
99	Y	-	-	-	-
100	BR	-	-	-	-
100	W	-	-	-	-

Connector No.	M24
Connector Name	CAN GATEWAY
Connector Type	TH12FW-NH



Terminal No.	Color Of Wire	Signal Name (Specification)
1	L	CAN-H (CAN COMMUNICATION CIRCUIT 1)
3	W	BATTERY POWER SUPPLY
4	L	CAN-H (CAN COMMUNICATION CIRCUIT 2)
5	B	GROUND
6	L	CAN-H (CAN COMMUNICATION CIRCUIT 2)
7	P	CAN-L (CAN COMMUNICATION CIRCUIT 1)
9	R	IGNITION POWER SUPPLY (With VR30 engine)
9	W	IGNITION POWER SUPPLY (With 2.0L turbo gasoline engine)
10	R	CAN-L (CAN COMMUNICATION CIRCUIT 2)
11	B	GROUND
12	R	CAN-L (CAN COMMUNICATION CIRCUIT 2)

Connector No.	M25
Connector Name	DATA LINK CONNECTOR
Connector Type	BD16FW



Terminal No.	Color Of Wire	Signal Name (Specification)
3	LG	M CAN_L
4	B	EARTH
5	B	EARTH
6	L	CAN-H
7	V	KLINE (With 2.0L turbo gasoline engine)
7	W	KLINE (With VR30 engine)
8	W	IGN_SW
11	SB	M CAN_H
12	R	CAN-L
13	L	CAN-H
14	P	CAN-L
16	W	POWER

Connector No.	M33
Connector Name	WIRE TO WIRE
Connector Type	NH60MM-TS12

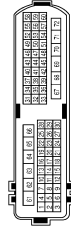

Terminal No.	Color Of Wire	Signal Name (Specification)
6	R	-
8	GR	-
9	GR	-
10	W	-
11	SHIELD	-
12	P	-
13	SB	-
14	LG	-

# AROUND VIEW MONITOR SYSTEM

## [AROUND VIEW MONITOR SYSTEM]

< WIRING DIAGRAM >

### AROUND VIEW MONITOR SYSTEM (2.0L TURBO GASOLINE ENGINE)

Terminal No.	Color	Wire	Signal Name [Specification]
15	Y	-	-
16	Y	-	-
17	P	-	-
18	W/B	-	-
19	LG	- [With DRPC]	-
19	LG	- [Without DRPC]	-
20	V	-	-
21	B	-	-
22	BG	- [Without DRPC]	-
22	G	- [With DRPC]	-
23	V	-	-
24	V	-	-
25	BG	- [Without DRPC]	-
25	L	- [With DRPC]	-
27	GR	-	-
28	V	-	-
29	B	-	-
30	W	-	-
31	B	-	-
32	SB	-	-
33	L	-	-
34	BR	-	-
35	LG	-	-
36	W	-	-
37	B	-	-
38	R	-	-
39	B	-	-
40	P	-	-
41	SB	-	-
43	W	- [With 2.0L turbo gasoline engine]	-
43	Y	- [With VR30 engine]	-
44	BG	-	-
46	BR	-	-
47	G	-	-
49	V	-	-
50	B	- [With DRPC]	-
50	BR	- [Without DRPC]	-
52	BR	-	-
52	B	-	-
54	L	-	-
55	BG	- [Without DRPC]	-
55	LG	- [With DRPC]	-
57	V	-	-
58	R	-	-
59	G	-	-
60	L	- [With DRPC]	-
61	G	-	-
62	R	-	-
63	V	- [Without DRPC]	-
64	B	- [With DRPC]	-
65	R	-	-

66	BR	-	-
68	P	-	-
69	V	-	-
70	W	-	-
71	LG	-	-
72	V	-	-

Connector No.	M24
Connector Name	WIRE TO WIRE
Connector Type	MHG0MW-TS12

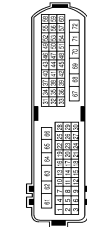

Terminal No.	Color	Wire	Signal Name [Specification]
1	V	-	-
2	R	-	-
5	L	-	-
6	R	-	-
8	W	-	-
9	GR	-	-
10	V	-	-
11	Y	-	-
13	LG	-	-
16	G	-	-
17	B	-	-
18	W	-	-
19	B	-	-
20	SB	- [With DRPC]	-
20	V	- [Without DRPC]	-
21	SHIELD	-	-
22	B	-	-
23	BG	- [Without DRPC]	-
23	P	- [With DRPC]	-
24	G	-	-
25	LG	-	-
26	BG	- [Without DRPC]	-
26	BR	- [With DRPC]	-
27	R	-	-
28	SB	-	-
29	BG	- [Without DRPC]	-
29	W/B	- [With DRPC]	-
30	L	-	-

38	R	-	-
39	B	-	-
49	P	-	-
51	V	-	-
52	V	-	-
55	B	-	-
56	SB	-	-
57	G	-	-
58	LG	-	-
59	LG	-	-
60	R	-	-
63	B	-	-
64	R	-	-
65	BR	-	-
66	Y	-	-
69	BR	-	-
70	Y	-	-
71	SB	-	-
72	W	-	-

Connector No.	M55
Connector Name	MULTIFUNCTION SWITCH
Connector Type	TH12FM-AH

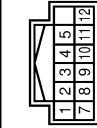

Terminal No.	Color	Wire	Signal Name [Specification]
1	BR	-	-
2	W	-	-
3	R	-	-
4	R	-	-
5	W	-	-
7	V	-	-
8	W	-	-
9	G	-	-
10	B	-	-
11	B	-	-
12	L	-	-

Connector No.	M76
Connector Name	SONAR CONTROL UNIT
Connector Type	TH24FW-AH

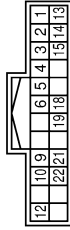

Terminal No.	Color	Wire	Signal Name [Specification]
1	SB	-	-
2	LG	-	-
3	W	-	-
4	GR	-	-
5	L	-	-
6	P	-	-
6	R	-	-
9	G	-	-
10	BG	-	-
12	R	-	-
12	W	-	-
13	B	-	-
14	B	-	-
15	B	-	-
18	GR	-	-
19	P	-	-
21	BR	-	-
22	W	-	-

Connector No.	M77
Connector Name	STEERING ANGLE SENSOR
Connector Type	TH08FM-AH



JRNWF7545GB

A  
B  
C  
D  
E  
F  
G  
H  
I  
J  
K  
L  
M  
O  
P

AV

# AROUND VIEW MONITOR SYSTEM

## [AROUND VIEW MONITOR SYSTEM]

< WIRING DIAGRAM >

### AROUND VIEW MONITOR SYSTEM (2.0L TURBO GASOLINE ENGINE)

Terminal No.	Color Of Wire	Signal Name [Specification]
1	B	GROUND
2	P	CAN-L [Without Gateway]
3	R	CAN-L [With Gateway]
4	G	IGN
5	L	CAN-H

Connector No.	M97
Connector Name	BACK-UP LAMP RELAY
Connector Type	M92FL-M2-LC



Terminal No.	Color Of Wire	Signal Name [Specification]
1	R	-
2	SB	- [With 2.0L turbo gasoline engine]
3	W	- [With VR30 engine]
5	BR	-

Connector No.	M100
Connector Name	DISPLAY CONTROL UNIT
Connector Type	TH24FW-NH

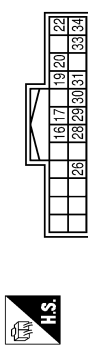

Terminal No.	Color Of Wire	Signal Name [Specification]
16	LG	AV COMMUNICATION SIGNAL (L)
17	P	CAN-L
19	R	DIMMER SIGNAL
20	BR	REVERSE SIGNAL
22	B	GROUND
26	BR	CAMERA SWITCH SIGNAL

Terminal No.	Color Of Wire	Signal Name [Specification]
28	SB	AV COMMUNICATION SIGNAL (R)
29	L	CAN-H
30	R	IGNITION SIGNAL [With VR30 engine]
30	W	IGNITION SIGNAL [With 2.0L turbo gasoline engine]
31	R	VEHICLE SPEED SIGNAL (8-PULSE)
33	SB	ACC POWER SUPPLY
34	Y	BATTERY POWER SUPPLY

Connector No.	M101
Connector Name	DISPLAY CONTROL UNIT
Connector Type	TH40FM-NH

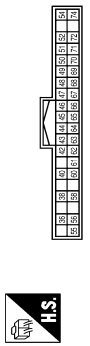

Terminal No.	Color Of Wire	Signal Name [Specification]
36	LG	COMPOSITE IMAGE SIGNAL (-)
38	SHIELD	SHIELD
40	SHIELD	MANUFACTURER SPECIFIC SIGNAL
42	G	SOUND SIGNAL RH (-)
43	SHIELD	SHIELD
44	L	SOUND SIGNAL LH (-)
45	W	TEL VOICE SIGNAL (-)
46	SHIELD	SHIELD
47	R	VOICE GUIDANCE SIGNAL OUTPUT (-)
48	B	VOICE GUIDANCE SIGNAL INPUT (-)
49	W	NS ON/OFF SIGNAL
50	R	MICROPHONE SIGNAL GROUND (WITH NAVIGATION)
51	SHIELD	SHIELD
52	SHIELD	MICROPHONE SIGNAL GROUND
54	W	CAMERA POWER SUPPLY GROUND
55	SHIELD	SHIELD
56	BR	COMPOSITE IMAGE SIGNAL (+)
58	B	CAMERA IMAGE SIGNAL
60	W	SOUND SIGNAL (-)
61	B	SOUND SIGNAL (+)
62	R	SOUND SIGNAL RH (+)
63	SHIELD	SHIELD
64	V	SOUND SIGNAL LH (+)
65	B	TEL VOICE SIGNAL (+)
66	SHIELD	SHIELD
67	G	VOICE GUIDANCE SIGNAL OUTPUT (+)
68	W	VOICE GUIDANCE SIGNAL INPUT (+)

Connector No.	M110
Connector Name	BUZZER
Connector Type	TH04FW-NH

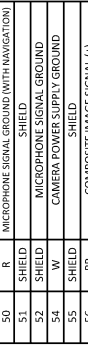

Terminal No.	Color Of Wire	Signal Name [Specification]
2	P	-
3	GR	-

Terminal No.	Color Of Wire	Signal Name [Specification]
69	SHIELD	SHIELD
70	G	MICROPHONE SIGNAL (NAVI)
71	G	MICROPHONE SIGNAL [Without telematics system]
71	R	MICROPHONE SIGNAL [With telematics system]
72	L	MICROPHONE VCC
74	R	CAMERA POWER SUPPLY

Connector No.	M105
Connector Name	DISPLAY CONTROL UNIT
Connector Type	Tyco_1554987-6

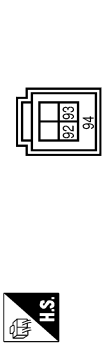

Terminal No.	Color Of Wire	Signal Name [Specification]
92	W	LVDS (+)
93	B	LVDS (-)
94	SHIELD	SHIELD

Connector No.	M110
Connector Name	BUZZER
Connector Type	TH04FW-NH



Connector No.	M133
Connector Name	FUSE BLOCK (J/B)
Connector Type	TH40FW-NH



Terminal No.	Color Of Wire	Signal Name [Specification]
10C	V	-
12C	L	-
13C	L	-
14C	Y	-
15C	R	-
16C	R	-
17C	L	-
18C	BG	- [Without DRPO]
18C	P	- [With DRPO]
19C	B	-
1C	R	-
20C	W	-
21C	L	-
22C	L	-
23C	L	-
23C	LG	-
26C	SB	-
27C	P	-
28C	W	-
29C	W	-
2C	R	-
30C	R	-
31C	W	-
32C	R	-
33C	B	- [With VR30 engine]
33C	R	- [With 2.0L turbo gasoline engine]
34C	W/B	-
35C	SB	-
36C	R	-
37C	W	-
38C	SB	-
39C	V	-
3C	P	-
40C	G	-
4C	P	-
5C	P	-

# AROUND VIEW MONITOR SYSTEM

## [AROUND VIEW MONITOR SYSTEM]

< WIRING DIAGRAM >

### AROUND VIEW MONITOR SYSTEM (2.0L TURBO GASOLINE ENGINE)

6C	G	-	-
7C	G	-	-
8C	G	-	-
9C	V	-	-

Connector No.	M135
Connector Name	JOINT CONNECTOR-M09
Connector Type	24342_4GA2A



6	5	4	3	2	1
11	10	9	8	7	6
16	15	14	13	12	11
24	23	22	21	20	19

Terminal No.	Color Of Wire	Signal Name [Specification]
1	B	-
2	B	-
3	B	-
4	B	-
5	B	-
6	B	-
9	LG	-
10	LG	-
11	LG	-
13	SB	- [With VR30 engine]
14	B	- [With 2.0L turbo gasoline engine]
15	SB	- [With 2.0L turbo gasoline engine]
16	SB	- [With VR30 engine]
17	SB	- [With 2.0L turbo gasoline engine]
18	SB	- [With VR30 engine]
19	Y	- [With 2.0L turbo gasoline engine]
20	SHIELD	- [With VR30 engine]
21	R	-
22	SHIELD	-
23	L	-
24	L	-

Connector No.	M137
Connector Name	JOINT CONNECTOR-M10
Connector Type	24342_4GA2A



5	4	3	2	1
11	10	9	8	7
16	15	14	13	12
24	23	22	21	19

Terminal No.	Color Of Wire	Signal Name [Specification]
1	B	-
2	B	-
3	B	-
4	B	-
5	B	-
7	B	-
8	B	-
9	B	-
10	B	-
11	B	-
13	L	-
15	L	-
16	L	-
19	R	-
21	R	-
22	R	-

Connector No.	M144
Connector Name	TCU
Connector Type	TH40FB-NH



1	2	3	4	5	6	7	8	9	10	11	12	13	14	15	16	17	18	19	20	21	22	23	24
---	---	---	---	---	---	---	---	---	----	----	----	----	----	----	----	----	----	----	----	----	----	----	----

Terminal No.	Color Of Wire	Signal Name [Specification]
1	Y	BATTERY POWER SUPPLY
2	SB	ACC POWER SUPPLY [With 2.0L turbo gasoline engine]
2	V	ACC POWER SUPPLY [With VR30 engine]
3	SB	ACC OUTPUT

5	BR	SOS SWITCH-LED SIGNAL
6	L	CAN-H
7	P	CAN-L
10	R	IGNITION SIGNAL [With VR30 engine]
10	W	IGNITION SIGNAL [With 2.0L turbo gasoline engine]
11	SHIELD	MICROPHONE SIGNAL GROUND
12	R	SHIELD
16	SHIELD	SHIELD
17	G	MICROPHONE SIGNAL
18	G	MICROPHONE VCC
26	SB	AV COMMUNICATION SIGNAL (H)
27	LG	AV COMMUNICATION SIGNAL (L)
28	B	GROUND
29	B	SHIELD
30	SHIELD	SHIELD
31	B	SOUND SIGNAL (+)
32	W	SOUND SIGNAL (-)
37	G	SOS CALL SWITCH SIGNAL

Connector No.	M146
Connector Name	WIRE TO WIRE
Connector Type	TK36MW-NS10



1	2	3	4	5	6	7	8	9	10	11	12	13	14	15	16	17	18	19	20	21	22	23	24
---	---	---	---	---	---	---	---	---	----	----	----	----	----	----	----	----	----	----	----	----	----	----	----

Terminal No.	Color Of Wire	Signal Name [Specification]
5	R	-
8	GR	-
9	V	-
10	BG	-
11	L	-
12	P	-
13	SB	-
14	Y	-
15	G	-
16	BR	-
17	W	-
18	R	-
19	L	-
20	SHIELD	-
21	BR	-
22	B	-

23	G	-
24	L	-
25	R	-
26	G	-
28	L	-
29	P	-
30	Y	-
31	GR	-
32	SB	-
33	BG	-
34	W	-
35	G	-
36	R	-
37	SHIELD	-
38	B	-
39	W	-
40	B	-
41	GR	-
42	B	-
43	LG	-
44	B	-
45	SB	-
46	B	-

Connector No.	M173
Connector Name	JOINT CONNECTOR-M03
Connector Type	24342_4GA2A



6	5	4	3	2	1
12	11	10	9	8	7
18	17	16	15	14	13
24	23	22	21	20	19

Terminal No.	Color Of Wire	Signal Name [Specification]
1	L	-
2	L	-
3	L	-
4	L	-
5	L	-
6	L	-
7	R	-
8	R	-
9	R	-
10	R	-
11	R	-

A  
B  
C  
D  
E  
F  
G  
H  
I  
J  
K  
L  
M  
N  
O  
P

AV

# AROUND VIEW MONITOR SYSTEM

## [AROUND VIEW MONITOR SYSTEM]

< WIRING DIAGRAM >

### AROUND VIEW MONITOR SYSTEM (2.0L TURBO GASOLINE ENGINE)

12	R	-	-
13	SB	-	-
14	SB	-	-
15	SB	-	-
16	L	- [With 2.0L turbo gasoline engine]	-
17	L	- [With VR30 engine]	-
18	L	- [With 2.0L turbo gasoline engine]	-
19	BR	- [With VR30 engine]	-
20	BR	- [With 2.0L turbo gasoline engine]	-
21	BR	- [With VR30 engine]	-
22	SB	- [With 2.0L turbo gasoline engine]	-
23	SB	- [With VR30 engine]	-
24	R	- [With 2.0L turbo gasoline engine]	-
24	SB	- [With VR30 engine]	-

Connector No.	M174
Connector Name	JOINT CONNECTOR-M04
Connector Type	24342_4GAZA

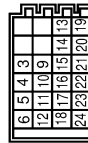

Terminal No.	Color Of Wire	Signal Name [Specification]
3	L	-
4	L	-
5	L	-
6	L	-
9	Y	-
10	Y	-
11	Y	-
12	Y	-
13	SB	-
14	SB	-
15	SB	-
16	SB	-

17	SB	-	-
18	SB	-	-
19	LG	-	-
20	LG	-	-
21	LG	-	-
22	LG	-	-
23	LG	-	-
24	LG	-	-

Connector No.	M175
Connector Name	JOINT CONNECTOR-M05
Connector Type	18H28FL-DC



Terminal No.	Color Of Wire	Signal Name [Specification]
1	L	-
2	L	-
3	L	-
4	L	-
5	L	-
6	L	-
7	L	-
8	L	-
10	P	-
11	P	-
12	P	-
13	P	-
14	P	-
15	P	-
16	P	-
17	W	-
18	W	-
19	W	-
20	W	-

Connector No.	M178
Connector Name	JOINT CONNECTOR-M08
Connector Type	18H28F-WDC

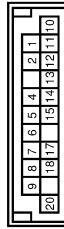

Terminal No.	Color Of Wire	Signal Name [Specification]
1	R	-
2	R	-
4	LG	- [With 2.0L turbo gasoline engine]
4	B	- [With VR30 engine]

Connector No.	M177
Connector Name	JOINT CONNECTOR-M07
Connector Type	24342_4GAZA

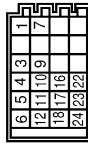

Terminal No.	Color Of Wire	Signal Name [Specification]
1	L	-
3	L	-
4	L	-
5	L	-
6	L	-
7	P	-
9	P	-
10	P	-
11	P	-
12	P	-
16	L	-
17	L	-
18	L	-
22	P	-
23	P	-
24	P	-

Connector No.	T48
Connector Name	WIRE TO WIRE
Connector Type	NS16FW-CS

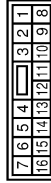

Terminal No.	Color Of Wire	Signal Name [Specification]
1	Y	-
2	BG	-
4	L	-
5	P	-
6	G	-
8	B	-
9	R	-
10	P	-
11	L	-
13	G	- [With around view monitor]
13	L	- [With rear view monitor]
14	B	- [With rear view monitor]

# AROUND VIEW MONITOR SYSTEM

< WIRING DIAGRAM >

[AROUND VIEW MONITOR SYSTEM]

## AROUND VIEW MONITOR SYSTEM (2.0L TURBO GASOLINE ENGINE)

14	R	- [With around view monitor]
15	B	- [With around view monitor]
15	W	- [With rear view monitor]
16	R	- [With rear view monitor]
16	W	- [With around view monitor]

Connector No.	T50
Connector Name	REAR CAMERA
Connector Type	TH03RM-NH



Terminal No.	Color Of Wire	Signal Name [Specification]
1	SHIELD	-
4	G	-
5	R	-
7	B	-
8	W	-

A  
B  
C  
D  
E  
F  
G  
H  
I  
J  
K  
L  
M  
N  
O  
P

AV

JRNWF7549GB

# AROUND VIEW MONITOR SYSTEM

[AROUND VIEW MONITOR SYSTEM]

< WIRING DIAGRAM >

VR ENGINE

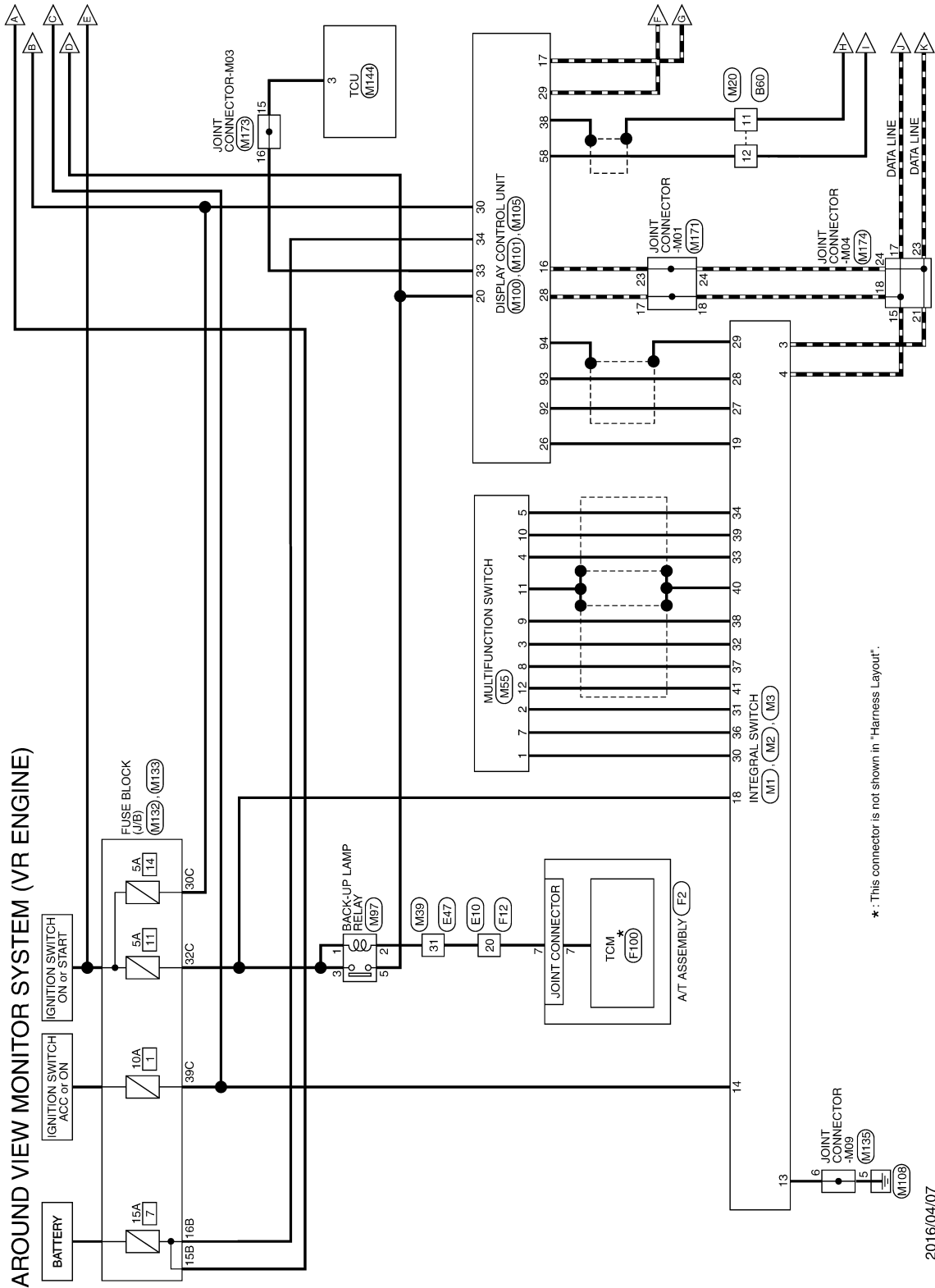

2016/04/07

JRNWF7510GB

# AROUND VIEW MONITOR SYSTEM

< WIRING DIAGRAM >

[AROUND VIEW MONITOR SYSTEM]

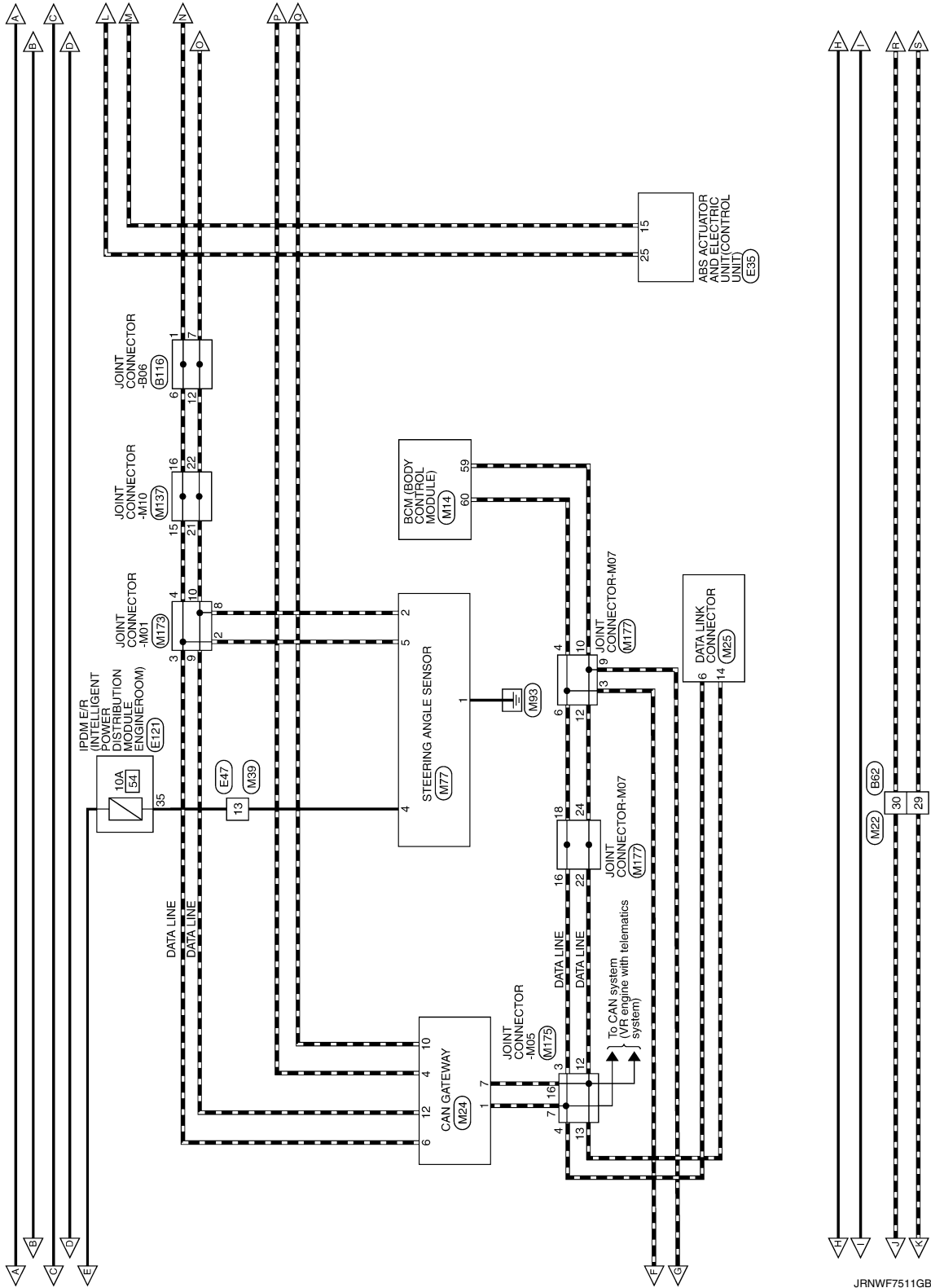

JRNWF7511GB

A  
B  
C  
D  
E  
F  
G  
H  
I  
J  
K  
L  
M  
N  
O  
P

AV

# AROUND VIEW MONITOR SYSTEM

< WIRING DIAGRAM >

[AROUND VIEW MONITOR SYSTEM]

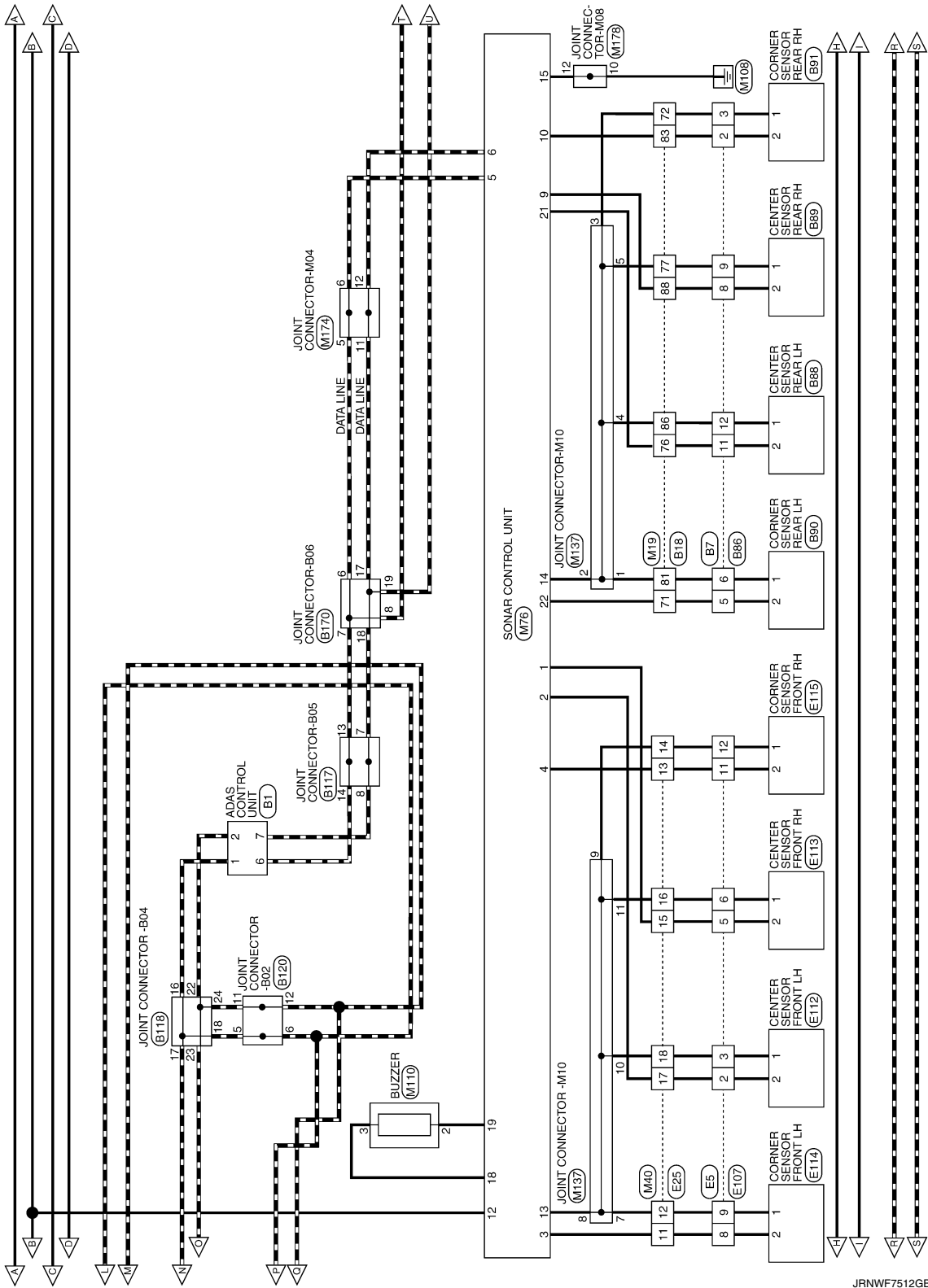

JRNWF7512GB

# AROUND VIEW MONITOR SYSTEM

< WIRING DIAGRAM >

[AROUND VIEW MONITOR SYSTEM]

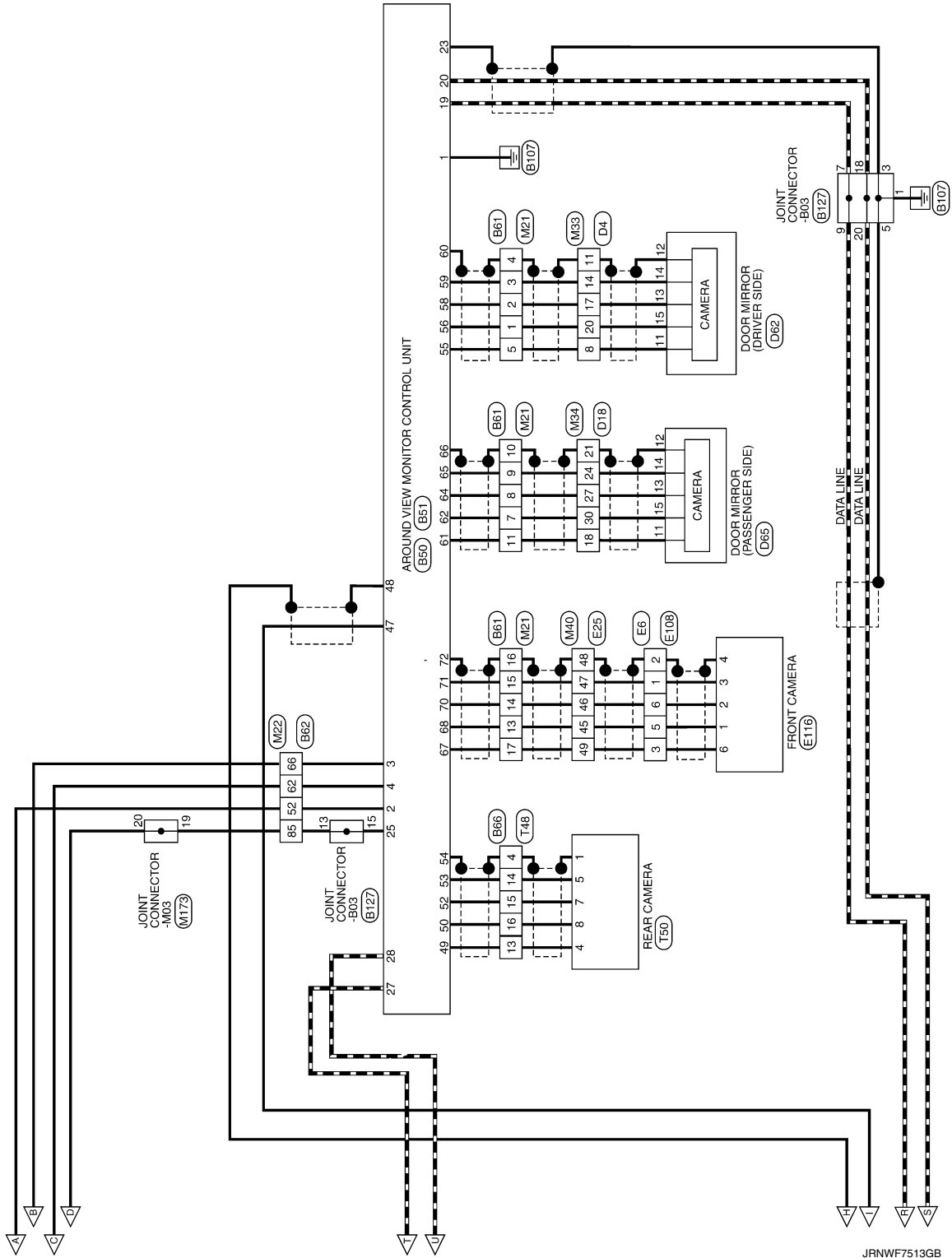

JRNWF7513GB

A  
B  
C  
D  
E  
F  
G  
H  
I  
J  
K  
L  
M  
N  
O  
P

AV

# AROUND VIEW MONITOR SYSTEM

## [AROUND VIEW MONITOR SYSTEM]

< WIRING DIAGRAM >

### AROUND VIEW MONITOR SYSTEM (VR ENGINE)

Connector No.	B1
Connector Name	ADAS CONTROL UNIT
Connector Type	TH24FW-AH

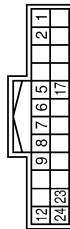

Terminal No.	Color Of Wire	Signal Name [Specification]
1	L	CAN-H
2	R	CAN-L
5	B	GROUND
6	L	ITS COMMUNICATION-H
7	P	ITS COMMUNICATION-L
8	L	CHASSIS COMMUNICATION-H
9	R	CHASSIS COMMUNICATION-L
12	G	IGNITION POWER SUPPLY [With 2.0L turbo gasoline engine]
12	GR	IGNITION POWER SUPPLY [With VR30 engine]
17	V	BRAKE HOLD R/LY DRIVE SIGNAL
23	Y	STEERING SW SIGNAL GROUND
24	SB	STEERING SW SIGNAL

Connector No.	B7
Connector Name	WIRE TO WIRE
Connector Type	TH12MW-AH

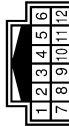

Terminal No.	Color Of Wire	Signal Name [Specification]
1	B	-
2	BG	-
3	B	-
4	R	-
5	W	-
6	B	-
7	R	-

8	G	-
9	B	-
10	GR	-
11	BR	-
12	B	-

Connector No.	B18
Connector Name	WIRE TO WIRE
Connector Type	TH80FW-CS15-TM4

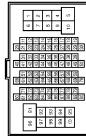

Terminal No.	Color Of Wire	Signal Name [Specification]
1	Y	-
2	G	-
3	L	-
5	Y	-
7	V	-
10	BG	-
11	BG	-
12	LG	-
13	GR	-
14	R	-
15	L	-
16	V	-
18	W	-
19	BR	-
20	W	-
22	R	-
23	V	-
24	R	- [With 2.0L turbo gasoline engine]
24	V	- [With VR30 engine]
25	V	- [With 2.0L turbo gasoline engine]
25	W	- [With VR30 engine]
26	G	-
27	R	-
28	R	-
31	B	- [With VR30 engine]
31	BR	- [With 2.0L turbo gasoline engine]
32	B	-
33	B	-

34	LG	-
35	P	-
36	W	-
37	S8	-
38	LG	-
40	P	-
41	S8	-
42	BR	-
43	BG	-
44	BG	-
46	R	-
50	W	-
51	S8	-
52	V	-
53	LG	-
54	R	-
55	R	-
58	V	-
59	GR	-
60	G	-
61	G	-
62	BG	-
63	BR	-
64	Y	-
66	R	-
70	R	-
71	W	-
72	B	-
74	L	-
74	L	-
75	R	-
76	BR	-
77	B	-
78	S8	-
79	W	-
81	B	-
82	R	-
83	BG	-
84	V	-
85	R	-
86	B	-
88	G	-
89	V	-
91	GR	-
93	GR	-
94	GR	-
96	Y	-
98	BR	- [With VR30 engine and with BOSE system]
98	Y	- [Except with VR30 engine and with BOSE system]

Connector No.	B50
Connector Name	AROUND VIEW MONITOR CONTROL UNIT
Connector Type	TH40FW-AH

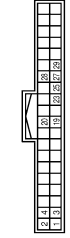

Terminal No.	Color Of Wire	Signal Name [Specification]
1	B	GROUND
2	Y	BATTERY POWER SUPPLY
3	LG	IGNITION SIGNAL
4	P	ACC POWER SUPPLY
19	P	AV COMMUNICATION SIGNAL [H]
20	LG	AV COMMUNICATION SIGNAL [L]
23	SHIELD	AV COMMUNICATION SIGNAL GROUND
25	BG	REVERSE SIGNAL
27	L	CAN-H
28	P	CAN-L [With ADAS]
28	R	CAN-L [Without ADAS]
29	SHIELD	CAN COMMUNICATION SIGNAL GROUND

Connector No.	B51
Connector Name	AROUND VIEW MONITOR CONTROL UNIT
Connector Type	TH24FW-AH



Terminal No.	Color Of Wire	Signal Name [Specification]
47	B	CAMERA IMAGE SIGNAL
48	SHIELD	CAMERA IMAGE SIGNAL GROUND
49	W	REAR CAMERA COMMUNICATION SIGNAL
50	B	REAR CAMERA POWER SUPPLY
52	R	REAR CAMERA GROUND
53	G	REAR CAMERA IMAGE SIGNAL (+)
54	SHIELD	REAR CAMERA IMAGE SIGNAL (-)

# AROUND VIEW MONITOR SYSTEM

## [AROUND VIEW MONITOR SYSTEM]

< WIRING DIAGRAM >

### AROUND VIEW MONITOR SYSTEM (VR ENGINE)

Terminal No.	Color Of Wire	Signal Name [Specification]
55	GR	SIDE CAMERA DRIVER SIDE COMMUNICATION SIGNAL
56	V	SIDE CAMERA DRIVER SIDE POWER SUPPLY
58	P	SIDE CAMERA DRIVER SIDE GROUND
59	LG	SIDE CAMERA DRIVER SIDE IMAGE SIGNAL (4)
60	SHIELD	SIDE CAMERA DRIVER SIDE IMAGE SIGNAL (4)
61	W	SIDE CAMERA PASSENGER SIDE COMMUNICATION SIGNAL
62	L	SIDE CAMERA PASSENGER SIDE POWER SUPPLY
64	R	SIDE CAMERA PASSENGER SIDE GROUND
65	G	SIDE CAMERA PASSENGER SIDE IMAGE SIGNAL (4)
66	SHIELD	SIDE CAMERA PASSENGER SIDE IMAGE SIGNAL (4)
67	B	FRONT CAMERA COMMUNICATION SIGNAL
68	W	FRONT CAMERA POWER SUPPLY
70	G	FRONT CAMERA GROUND
71	R	FRONT CAMERA IMAGE SIGNAL (4)
72	SHIELD	FRONT CAMERA IMAGE SIGNAL (4)

Connector No.	Connector Name	Connector Type
B60	WIRE TO WIRE	TH16FW-NH



Terminal No.	Color Of Wire	Signal Name [Specification]
7	R	
8	L	
10	Y	
11	SHIELD	
12	B	
13	W	
14	R	

Connector No.	Connector Name	Connector Type
B61	WIRE TO WIRE	TH24FW-AH

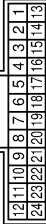

Terminal No.	Color Of Wire	Signal Name [Specification]
1	V	
2	P	
3	LG	
4	SHIELD	
5	GR	
7	L	
8	R	
9	G	
10	SHIELD	
11	G	
12	Y	
13	R	
14	BG	
15	BG	
16	GR	
17	V	
18	L	
19	G	
20	GR	
21	R	
23	W	
24	BG	
25	V	
26	G	
27	R	
28	R	
29	LG	
30	P	
31	SHIELD	
32	L	
33	B	
34	SHIELD	

Connector No.	Connector Name	Connector Type
B62	WIRE TO WIRE	TH80FW-CS16-TM4

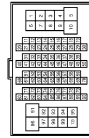

Terminal No.	Color Of Wire	Signal Name [Specification]
1	BR	
1	LG	
1	W	

Terminal No.	Color Of Wire	Signal Name [Specification]
35	LG	
36	W	
37	P	
37	R	
38	L	
38	L	
39	P	
39	W	
39	R	
39	W	
40	G	
41	L	
42	R	
43	SHIELD	
44	P	
45	B	
45	G	
46	SHIELD	
47	G	
48	BG	
49	G	
51	GR	
51	L	
52	W	
52	Y	
53	R	
54	GR	
55	L	
56	V	
57	R	
58	LG	
59	P	
60	BR	
61	L	
61	R	
62	P	
62	Y	
63	L	
64	W	
65	R	
66	L	
66	LG	
67	G	
68	L	
69	P	
71	GR	
71	R	
72	G	

Terminal No.	Color Of Wire	Signal Name [Specification]
2	L	
2	SHIELD	
3	BR	
3	R	
3	W	
4	SHIELD	
4	Y	
5	G	
5	V	
6	BG	
6	BR	
7	B	
7	BR	
7	W	
7	Y	
8	B	
8	G	
8	Y	
9	LG	
9	SHIELD	
10	V	
11	GR	
12	Y	
13	R	
14	BG	
15	BG	
15	GR	
16	V	
17	P	
18	L	
19	G	
20	GR	
21	R	
23	W	
24	BG	
24	V	
25	L	
25	B	
26	G	
26	W	
27	R	
28	R	
29	LG	
30	P	
31	SHIELD	
32	L	
33	B	
33	LG	
34	SHIELD	

A  
B  
C  
D  
E  
F  
G  
H  
I  
J  
K  
L  
M  
N  
O  
P

AV

# AROUND VIEW MONITOR SYSTEM

## [AROUND VIEW MONITOR SYSTEM]

< WIRING DIAGRAM >

### AROUND VIEW MONITOR SYSTEM (VR ENGINE)

72	Y	- [With 2.0L turbo gasoline engine]
73	R	- [With 2.0L turbo gasoline engine]
73	SHIELD	- [With VR30 engine]
74	BG	- [With 2.0L turbo gasoline engine]
74	L	- [With VR30 engine]
75	GR	- [With 2.0L turbo gasoline engine]
75	V	- [With VR30 engine]
76	GR	- [With VR30 engine]
76	V	- [With 2.0L turbo gasoline engine]
77	P	-
77	L	-
78	G	-
80	GR	- [With 2.0L turbo gasoline engine]
80	W	- [With VR30 engine]
81	B	- [With VR30 engine]
81	R	- [With 2.0L turbo gasoline engine]
82	G	- [With 2.0L turbo gasoline engine]
82	SHIELD	- [With VR30 engine]
83	R	- [With 2.0L turbo gasoline engine]
83	W	- [With VR30 engine]
84	BR	- [With VR30 engine]
84	SHIELD	- [With 2.0L turbo gasoline engine]
85	BG	- [With VR30 engine]
85	G	- [With 2.0L turbo gasoline engine]
86	R	-
87	LG	- [With VR30 engine]
87	SHIELD	- [With 2.0L turbo gasoline engine]
88	R	-
89	LG	-
90	P	-
92	L	- [With 2.0L turbo gasoline engine]
92	W	- [With VR30 engine]
93	SHIELD	-
94	R	-
95	L	- [With 2.0L turbo gasoline engine]
95	Y	- [With VR30 engine]
96	W	-
97	L	- [With VR30 engine]
97	R	- [With 2.0L turbo gasoline engine and with BOSE system]
97	W	- [With 2.0L turbo gasoline engine and without BOSE system]
98	BR	- [With VR30 engine and with BOSE system]
99	P	- [With 2.0L turbo gasoline engine]
99	Y	- [With VR30 engine and without BOSE system]
100	BR	- [With VR30 engine]
100	W	- [With 2.0L turbo gasoline engine]

Connector No.	B86
Connector Name	WIRE TO WIRE
Connector Type	N516MW-CS

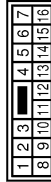

Terminal No.	Color Of Wire	Signal Name [Specification]
1	R	-
2	BG	-
4	SHIELD	-
5	W	-
6	GR	-
8	B	-
9	R	-
10	P	-
11	B	-
13	SHIELD	- [With rear view monitor]
13	W	- [With around view monitor]
14	B	- [With rear view monitor]
14	G	- [With around view monitor]
15	R	- [With around view monitor]
15	W	- [With rear view monitor]
16	B	- [With around view monitor]
16	R	- [With rear view monitor]

Connector No.	B86
Connector Name	WIRE TO WIRE
Connector Type	TH12FM-RH



Terminal No.	Color Of Wire	Signal Name [Specification]
1	B	-
2	BG	-
3	B	-

4	R	-
5	W	-
6	B	-
7	R	-
8	G	-
9	B	-
10	GR	-
11	BR	-
12	B	-



Connector No.	B90
Connector Name	CORNER SENSOR REAR LH
Connector Type	RH03FB

Connector No.	B88
Connector Name	CENTER SENSOR REAR LH
Connector Type	RH03FB



Terminal No.	Color Of Wire	Signal Name [Specification]
1	B	-
2	W	-

Connector No.	B91
Connector Name	CORNER SENSOR REAR RH
Connector Type	RH03FB



Terminal No.	Color Of Wire	Signal Name [Specification]
1	B	-
2	BR	-

Connector No.	B89
Connector Name	CENTER SENSOR REAR RH
Connector Type	RH03FB



Terminal No.	Color Of Wire	Signal Name [Specification]
1	B	-
2	BG	-

Terminal No.	Color Of Wire	Signal Name [Specification]
1	B	-
2	G	-

# AROUND VIEW MONITOR SYSTEM

## [AROUND VIEW MONITOR SYSTEM]

< WIRING DIAGRAM >

### AROUND VIEW MONITOR SYSTEM (VR ENGINE)

Connector No.	B116
Connector Name	JOINT CONNECTOR-B06
Connector Type	24342_4GAZA



6	5	4	3	2	1
12	11	10	9	8	7
18	17	16	15	14	13
24	23	22	21	20	19

Connector No.	B117
Connector Name	JOINT CONNECTOR-B05
Connector Type	24342_4GAZA



6	5	4	3	2	1
12	11	10	9	8	7
18	17	16	15	14	13
24	23	22	21	20	19

Connector No.	B118
Connector Name	JOINT CONNECTOR-B04
Connector Type	24342_4GAZA



6	5	4	3	2	1
12	11	10	9	8	7
18	17	16	15	14	13
24	23	22	21	20	19

21	L	-	[With 2.0L turbo gasoline engine]
21	SHIELD	-	[With VR30 engine]
22	R	-	-
23	R	-	-
24	R	-	-

Connector No.	B120
Connector Name	JOINT CONNECTOR-B02
Connector Type	24342_4GAZA



6	5	4	3	2	1
12	11	10	9	8	7
18	17	16	15	14	13
24	23	22	21	20	19

Terminal No.	Color Of Wire	Signal Name (Specification)
1	LG	- [With VR30 engine]
1	SHIELD	- [With 2.0L turbo gasoline engine]
2	LG	- [With VR30 engine]
2	SHIELD	- [With 2.0L turbo gasoline engine]
3	LG	- [With VR30 engine]
3	SHIELD	- [With 2.0L turbo gasoline engine]
4	LG	- [With VR30 engine]
4	SHIELD	- [With 2.0L turbo gasoline engine]
5	LG	- [With VR30 engine]
5	SHIELD	- [With 2.0L turbo gasoline engine]
6	LG	- [With VR30 engine]
6	SHIELD	- [With 2.0L turbo gasoline engine]
7	LG	- [With VR30 engine]
7	R	- [With 2.0L turbo gasoline engine]
8	R	- [With 2.0L turbo gasoline engine]
9	LG	- [With VR30 engine]
9	R	- [With 2.0L turbo gasoline engine]
10	LG	- [With VR30 engine]
10	SHIELD	- [With 2.0L turbo gasoline engine]
11	LG	- [With VR30 engine]
11	SHIELD	- [With 2.0L turbo gasoline engine]
12	LG	- [With VR30 engine]
12	SHIELD	- [With 2.0L turbo gasoline engine]
13	L	- [With VR30 engine]
13	R	- [With 2.0L turbo gasoline engine]
14	L	- [With VR30 engine]
14	R	- [With 2.0L turbo gasoline engine]
15	L	- [With VR30 engine]
15	R	- [With 2.0L turbo gasoline engine]
16	L	- [With VR30 engine]
16	L	- [With 2.0L turbo gasoline engine]
17	L	- [With VR30 engine]
17	L	- [With 2.0L turbo gasoline engine]
18	L	- [With VR30 engine]
18	L	- [With 2.0L turbo gasoline engine]
19	SHIELD	- [With VR30 engine]
19	SHIELD	- [With 2.0L turbo gasoline engine]
20	L	- [With VR30 engine]
20	L	- [With 2.0L turbo gasoline engine]

Terminal No.	Color Of Wire	Signal Name (Specification)
1	B	-
2	B	- [With 2.0L turbo gasoline engine]
2	SHIELD	- [With VR30 engine]
3	B	-
4	SHIELD	-
5	B	-
6	B	-
7	P	-
8	P	-
9	P	-
10	P	-
11	P	-
12	P	-
13	L	-
14	L	-
15	L	-
16	L	-
17	L	-
18	L	-
19	SHIELD	-
20	SHIELD	-
21	SHIELD	-
22	SHIELD	-
23	SHIELD	-
24	SHIELD	-

Terminal No.	Color Of Wire	Signal Name (Specification)
1	L	-
2	L	-
3	L	-
4	L	-
5	L	-
6	L	-
7	R	-
8	R	- [With Gateway]
8	V	- [Without Gateway]
9	R	- [With Gateway]
9	V	- [Without Gateway]
10	V	-
11	V	-
12	P	- [With 2.0L turbo gasoline engine]
12	P	- [With VR30 engine]
13	SHIELD	-
14	SHIELD	-
15	SHIELD	-
16	SHIELD	-
17	SHIELD	-
18	SHIELD	-
19	L	-
20	L	-
21	L	-
22	R	-
23	R	-
24	R	-

Terminal No.	Color Of Wire	Signal Name (Specification)
1	R	-
2	R	-
3	L	- [With VR30 engine]
3	R	- [With 2.0L turbo gasoline engine]
4	L	- [With VR30 engine]
4	R	- [With 2.0L turbo gasoline engine]
5	L	-
6	L	-
7	L	-
8	L	-
9	L	- [With 2.0L turbo gasoline engine]
9	R	- [With VR30 engine]
10	L	- [With 2.0L turbo gasoline engine]
10	R	- [With VR30 engine]
11	R	-
12	R	-
13	W	-
14	W	-
15	W	-
17	SHIELD	-
18	B	- [With 2.0L turbo gasoline engine]
19	B	- [With VR30 engine]
19	GR	- [With VR30 engine]
20	GR	-
20	SHIELD	- [With 2.0L turbo gasoline engine]
21	B	- [With 2.0L turbo gasoline engine]
21	GR	- [With VR30 engine]
22	W	-
23	W	-

A  
B  
C  
D  
E  
F  
G  
H  
I  
J  
K  
L  
M  
AV  
O  
P

# AROUND VIEW MONITOR SYSTEM

< WIRING DIAGRAM >

[AROUND VIEW MONITOR SYSTEM]

## AROUND VIEW MONITOR SYSTEM (VR ENGINE)

24	W								
Connector No.		B127							
Connector Name		JOINT CONNECTOR-B13							
Connector Type		NH2DFG-DC							



Terminal No.	Color Of Wire	Signal Name (Specification)
1	B	
2	SHIELD	
3	SHIELD	
4	SHIELD	
5	SHIELD	
6	P	
7	P	
8	P	
9	P	
10	LG	
11	LG	
13	BG	
14	BG	
15	BG	
17	LG	
18	LG	
19	LG	
20	LG	

B170									
Connector No.		B170							
Connector Name		JOINT CONNECTOR-B13							
Connector Type		NH2DFG-DC							

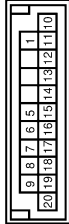

Terminal No.	Color Of Wire	Signal Name (Specification)
1	SHIELD	
5	SHIELD	
6	L	
7	L	
8	L	
9	L	
10	SHIELD	
11	SHIELD	
12	SHIELD	
13	SHIELD	
14	SHIELD	
15	SHIELD	
16	SHIELD	
17	P	
18	P	
19	P	
20	P	

D4									
Connector No.		D4							
Connector Name		WIRE TO WIRE							
Connector Type		NH6GFW-1S12							



Terminal No.	Color Of Wire	Signal Name (Specification)
6	V	
8	G	
9	GR	

10	Y	-	-	-	-
11	SHIELD	-	-	-	-
12	BG	-	-	-	-
13	L	-	-	-	-
14	B	-	-	-	-
15	Y	-	-	-	-
16	GR	-	-	-	-
17	R	-	-	-	-
18	GR	-	-	-	-
19	R	-	-	-	-
20	W	-	-	-	-
21	LG	-	-	-	-
22	W	-	-	-	-
23	L	-	-	-	-
24	G	-	-	-	-
25	BR	-	-	-	-
27	BR	-	-	-	-
28	V	-	-	-	-
29	B	-	-	-	-
30	W	-	-	-	-
31	P	-	-	-	-
32	Y	-	-	-	-
33	BR	-	-	-	-
34	L	-	-	-	-
35	R	-	-	-	-
36	GR	-	-	-	-
37	G	-	-	-	-
38	R	-	-	-	-
39	B	-	-	-	-
40	LG	-	-	-	-
41	L	-	-	-	-
43	BG	-	-	-	-
44	Y	-	-	-	-
46	W	-	-	-	-
47	R	-	-	-	-
49	BR	-	-	-	-
50	B	-	-	-	-
52	V	-	-	-	-
53	GR	-	-	-	-
54	R	-	-	-	-
55	B	-	-	-	-
56	BR	-	-	-	-
57	R	-	-	-	-
58	L	-	-	-	-
59	V	-	-	-	-
60	G	-	-	-	-
61	BG	-	-	-	-
62	Y	-	-	-	-
63	B	-	-	-	-
64	B	-	-	-	-

65	Y	-	-	-	-
66	BR	-	-	-	-
68	Y	-	-	-	-
69	L	-	-	-	-
70	W	-	-	-	-
71	LG	-	-	-	-
72	P	-	-	-	-

D18									
Connector No.		D18							
Connector Name		WIRE TO WIRE							
Connector Type		NH6GFW-1S12							

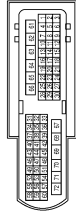

Terminal No.	Color Of Wire	Signal Name (Specification)
1	GR	
2	P	
5	BR	
6	Y	
8	W	
9	L	
10	L	
11	GR	
13	Y	
16	R	
17	B	
18	W	
19	R	
20	G	
21	SHIELD	
22	GR	
23	BG	
24	B	
25	BR	
26	V	
27	G	
28	V	
29	Y	
30	R	
38	R	
39	B	
49	B	

JRNWF7518GB

# AROUND VIEW MONITOR SYSTEM

< WIRING DIAGRAM >

[AROUND VIEW MONITOR SYSTEM]

## AROUND VIEW MONITOR SYSTEM (VR ENGINE)

Terminal No.	Color Of Wire	Signal Name [Specification]
51	R	-
52	P	-
55	L	-
56	Y	-
57	R	-
58	SB	-
59	R	-
60	G	-
63	B	-
64	Y	-
65	BR	-
66	GR	-
69	W	-
70	L	-
71	BG	-
72	Y	-

Connector No.	D62
Connector Name	DOOR MIRROR (DRIVER SIDE)
Connector Type	RH10MB



Terminal No.	Color Of Wire	Signal Name [Specification]
11	G	-
12	SHIELD	-
13	R	-
14	B	-
15	W	-
16	V	-
17	BR	-
18	LG	-
19	W	-
20	G	-

Connector No.	D65
Connector Name	DOOR MIRROR (PASSENGER SIDE)
Connector Type	RH10MB



Terminal No.	Color Of Wire	Signal Name [Specification]
11	W	-
12	SHIELD	-
13	G	-
14	B	-
15	R	-
16	Y	-
17	P	-
18	BR	-
19	W	-
20	GR	-

Connector No.	E5
Connector Name	WIRE TO WIRE
Connector Type	RH12MB



Terminal No.	Color Of Wire	Signal Name [Specification]
2	BR	-
3	P	-
4	GR	-
5	SB	-
6	Y	-
8	L	-
9	GR	-
10	B	-
11	W	-
12	B	-

Connector No.	E6
Connector Name	WIRE TO WIRE
Connector Type	RS06MB



Terminal No.	Color Of Wire	Signal Name [Specification]
1	G	-
2	SHIELD	-
3	R	-
5	W	-
6	B	-

Connector No.	E10
Connector Name	WIRE TO WIRE
Connector Type	5AA36MB-RS8-SHZ8

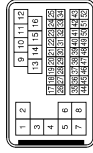

Terminal No.	Color Of Wire	Signal Name [Specification]
1	R	-
2	R	-
3	LG	-
4	R	-
5	G	-
7	V	-
8	W	-
9	W	-
10	BG	-
11	LG	-
12	BG	-
13	L	-
14	Y	-
15	LG	-
16	G	-

17	L	-
18	P	-
19	GR	-
20	G	-
21	GR	-
22	W	-
23	G	-
24	BG	-
25	V	-
26	BR	-
27	W	-
28	BG	-
29	LG	-
30	G	-
31	Y	-
32	R	-
33	B	-
34	V	-
35	LG	-
36	W	-
37	V	-
38	BR	-
39	GR	-
40	SHIELD	-
41	B	-
42	R	-
43	Y	-
44	SHIELD	-
45	Y	-
46	P	-
47	L	-
48	LG	-
49	BG	-
50	SHIELD	-
51	W	-
52	G	-

A  
B  
C  
D  
E  
F  
G  
H  
I  
J  
K  
L  
M  
N  
O  
P

AV

# AROUND VIEW MONITOR SYSTEM

## [AROUND VIEW MONITOR SYSTEM]

< WIRING DIAGRAM >

### AROUND VIEW MONITOR SYSTEM (VR ENGINE)

Connector No.	E25
Connector Name	WIRE TO WIRE
Connector Type	TH80FW-C3.16-TM4



Terminal No.	Color Of Wire	Signal Name [Specification]
1	BG	-
2	V	-
3	L	-
4	BG	- [With VR30 engine]
5	BR	- [With 2.0L turbo gasoline engine]
6	GR	- [With VR30 engine]
7	B	- [With 2.0L turbo gasoline engine]
8	BR	- [With VR30 engine]
9	GR	- [With VR30 engine]
10	BR	- [With VR30 engine]
11	L	- [With VR30 engine]
12	GR	- [With 2.0L turbo gasoline engine]
13	SHIELD	- [With 2.0L turbo gasoline engine]
14	B	- [With VR30 engine]
15	GR	- [With 2.0L turbo gasoline engine]
16	BR	- [With 2.0L turbo gasoline engine]
17	BR	- [With VR30 engine]
18	G	- [With 2.0L turbo gasoline engine]
19	V	- [With VR30 engine]
20	W	- [With 2.0L turbo gasoline engine]
21	Y	- [With VR30 engine]
22	G	- [With 2.0L turbo gasoline engine]
23	GR	- [With VR30 engine]
24	L	- [With VR30 engine]
25	V	- [With 2.0L turbo gasoline engine]
26	P	- [With VR30 engine]
27	Y	- [With 2.0L turbo gasoline engine]
28	R	- [With VR30 engine]
29	L	- [With 2.0L turbo gasoline engine]
30	B	- [With VR30 engine]
31	W	- [With 2.0L turbo gasoline engine]
32	G	- [With 2.0L turbo gasoline engine]
33	L	- [With VR30 engine]
34	P	- [With 2.0L turbo gasoline engine]
35	GR	- [With VR30 engine]
36	R	- [With 2.0L turbo gasoline engine]
37	V	- [With VR30 engine]
38	L	- [With VR30 engine]
39	R	- [With 2.0L turbo gasoline engine]

39	BR	- [With 2.0L turbo gasoline engine]
40	SB	- [With VR30 engine]
41	LG	- [With 2.0L turbo gasoline engine]
42	W	- [With VR30 engine]
43	B	- [With 2.0L turbo gasoline engine]
44	Y	- [With VR30 engine]
45	G	- [With 2.0L turbo gasoline engine]
46	SHIELD	- [With VR30 engine]
47	R	- [With 2.0L turbo gasoline engine]
48	BR	- [With VR30 engine]
49	GR	- [With VR30 engine]
50	L	- [With 2.0L turbo gasoline engine]
51	W	- [With VR30 engine]
52	P	- [With 2.0L turbo gasoline engine]
53	W	- [With VR30 engine]
54	B	- [With 2.0L turbo gasoline engine]
55	B	- [With VR30 engine]
56	BG	- [With 2.0L turbo gasoline engine]
57	BG	- [With VR30 engine]
58	B/W	- [With 2.0L turbo gasoline engine]
59	W	- [With VR30 engine]
60	R	- [With 2.0L turbo gasoline engine]
61	Y	- [With VR30 engine]
62	BR	- [With 2.0L turbo gasoline engine]
63	BR	- [With VR30 engine]
64	Y	- [With 2.0L turbo gasoline engine]
65	BR	- [With VR30 engine]
66	BG	- [With 2.0L turbo gasoline engine]
67	L	- [With VR30 engine]
68	BG	- [With 2.0L turbo gasoline engine]
69	L	- [With VR30 engine]
70	R	- [With 2.0L turbo gasoline engine]
71	G	- [With VR30 engine]
72	L	- [With 2.0L turbo gasoline engine]
73	G	- [With VR30 engine]
74	BR	- [With 2.0L turbo gasoline engine]
75	R	- [With VR30 engine]
76	G	- [With 2.0L turbo gasoline engine]
77	Y	- [With VR30 engine]
78	LG	- [With 2.0L turbo gasoline engine]
79	P	- [With VR30 engine]
80	B	- [With 2.0L turbo gasoline engine]
81	G	- [With VR30 engine]

81	R	-
82	V	- [With 2.0L turbo gasoline engine]
83	BR	- [With VR30 engine]
84	R	- [With 2.0L turbo gasoline engine]
85	LG	- [With VR30 engine]
86	BG	- [With 2.0L turbo gasoline engine]
87	G	- [With VR30 engine]
88	GR	- [With 2.0L turbo gasoline engine]
89	LG	- [With VR30 engine]
90	G	- [With 2.0L turbo gasoline engine]
91	G	- [With VR30 engine]
92	W	- [With 2.0L turbo gasoline engine]
93	BG	- [With VR30 engine]
94	GR	- [With 2.0L turbo gasoline engine]
95	R	- [With VR30 engine]
96	W	- [With 2.0L turbo gasoline engine]
97	LG	- [With VR30 engine]
98	L	- [With 2.0L turbo gasoline engine]
99	P	- [With VR30 engine]
100	SHIELD	- [With 2.0L turbo gasoline engine]

Connector No.	E35
Connector Name	ABS ACTUATOR AND ELECTRIC UNIT (CONTROL UNIT)
Connector Type	SAZ30FB-SJZ4-U

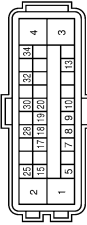

Terminal No.	Color Of Wire	Signal Name [Specification]
1	B	GROUND
2	B	GROUND
3	G	VALVE BATTERY [With VR30 engine]
4	P	VALVE BATTERY [With 2.0L turbo gasoline engine]
5	Y	MOTOR BATTERY
6	LG	STOP JUMP SW SIGNAL [With ADAS]
7	GR	STOP JUMP SW SIGNAL [With ASCD]
8	G	RR LH WHEEL SENSOR SIGNAL
9	BR	FR RH WHEEL SENSOR SIGNAL
10	GR	FR RH WHEEL SENSOR POWER SUPPLY

13	R	VACUUM SENSOR SIGNAL
14	R	CAN-L [Without Gateway]
15	P	CAN-L [With Gateway]
16	Y	RR RH WHEEL SENSOR SIGNAL
17	Y	RR RH WHEEL SENSOR SIGNAL
18	LG	RR RH WHEEL SENSOR POWER SUPPLY [With VR30 engine]
19	V	RR RH WHEEL SENSOR POWER SUPPLY [With 2.0L turbo gasoline engine]
20	SG	FR LH WHEEL SENSOR SIGNAL
21	SG	FR LH WHEEL SENSOR SIGNAL
22	L	CAN-H
23	G	VACUUM SENSOR POWER SUPPLY
24	R	VOC OFF SW SIGNAL
25	SHIELD	VACUUM SENSOR GROUND
26	G	IGN

Connector No.	E47
Connector Name	WIRE TO WIRE
Connector Type	TH32MM-NH



Terminal No.	Color Of Wire	Signal Name [Specification]
1	Y	-
2	V	-
3	L	-
4	P	- [Without Gateway]
5	R	- [With Gateway]
6	W	-
7	SR	-
8	BR	-
9	W	- [Without BOSE system]
10	V	- [With BOSE system]
11	SB	-
12	G	-
13	G	-
14	BR	-
15	P	-
16	SHIELD	-
17	L	-
18	Y	-
19	W	-
20	W	-

# AROUND VIEW MONITOR SYSTEM

## [AROUND VIEW MONITOR SYSTEM]

< WIRING DIAGRAM >

### AROUND VIEW MONITOR SYSTEM (VR ENGINE)

Connector No.	Color Of Wire	Signal Name [Specification]
21	G	-
22	R	-
23	BR	-
26	BG	-
27	LG	-
28	BR	-
29	W	-
30	Y	-
31	G	-
32	LG	-

Connector No.	Color Of Wire	Signal Name [Specification]
E107	WIRE TO WIRE	
Connector Name	RH12FB	
Connector Type		

Terminal No.	Color Of Wire	Signal Name [Specification]
1	L	-
2	BR	-
3	P	-
4	GR	-
5	SB	-
6	Y	-
7	L	-
8	L	-
9	GR	-
10	B	-
11	W	-
12	B	-

Connector No.	Color Of Wire	Signal Name [Specification]
E108	WIRE TO WIRE	
Connector Name	RS06FB-PR	
Connector Type		

Terminal No.	Color Of Wire	Signal Name [Specification]
1	G	-
2	SHIELD	-
3	W	-
5	R	-
6	B	-

Connector No.	Color Of Wire	Signal Name [Specification]
E112	CENTER SENSOR FRONT LH	
Connector Name	RH03FB	
Connector Type		

Terminal No.	Color Of Wire	Signal Name [Specification]
1	GR	-
2	L	-

Connector No.	Color Of Wire	Signal Name [Specification]
E113	CENTER SENSOR FRONT RH	
Connector Name	RH03FB	
Connector Type		

Terminal No.	Color Of Wire	Signal Name [Specification]
1	Y	-
2	SB	-

Connector No.	Color Of Wire	Signal Name [Specification]
E114	CORNER SENSOR FRONT LH	
Connector Name	RH03FB	
Connector Type		

Terminal No.	Color Of Wire	Signal Name [Specification]
1	GR	-
2	L	-

Connector No.	Color Of Wire	Signal Name [Specification]
E115	CORNER SENSOR FRONT RH	
Connector Name	RH03FB	
Connector Type		

Terminal No.	Color Of Wire	Signal Name [Specification]
1	B	-
2	W	-

Connector No.	Color Of Wire	Signal Name [Specification]
E116	FRONT CAMERA	
Connector Name	RH06MB	
Connector Type		

Terminal No.	Color Of Wire	Signal Name [Specification]
1	R	-
2	B	-
3	G	-
4	SHIELD	-
6	W	-

A  
B  
C  
D  
E  
F  
G  
H  
I  
J  
K  
L  
M  
AV  
O  
P

# AROUND VIEW MONITOR SYSTEM

## [AROUND VIEW MONITOR SYSTEM]

< WIRING DIAGRAM >

### AROUND VIEW MONITOR SYSTEM (VR ENGINE)

Connector No.	E123
Connector Name	IPM (R) INTELLIGENT POWER DISTRIBUTION MODULE ENGINE ROOM
Connector Type	TH32FW-NH

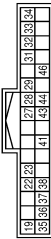

Terminal No.	Color Of Wire	Signal Name [Specification]
19	L	- [With 2.0L turbo gasoline engine]
19	P	- [With VR30 engine]
22	BG	-
23	GR	- [With VR30 engine]
23	LG	- [With 2.0L turbo gasoline engine and without anti-theft device]
23	P	- [With 2.0L turbo gasoline engine and with Anti-theft device]
27	GR	-
28	P	-
29	L	-
31	G	-
32	S8	-
33	S8	-
34	Y	-
35	G	- [With VR30 engine]
36	W	- [With 2.0L turbo gasoline engine]
37	GR	-
38	BR	-
41	GR	-
43	V	-
44	G	- [With 2.0L turbo gasoline engine]
44	GR	- [With VR30 engine]
46	R	- [With VR30 engine]
46	Y	- [With 2.0L turbo gasoline engine]

Connector No.	F2
Connector Name	A/T ASSEMBLY
Connector Type	RK1DFG-DGY



Terminal No.	Color Of Wire	Signal Name [Specification]
1	L	IGNITION POWER SUPPLY
2	P	BATTERY POWER SUPPLY (MEMORY BACK-UP)
3	L	CAN-H
4	R	K-LINE
5	BR	GROUND
6	GR	IGNITION POWER SUPPLY
7	BG	BACK-UP LAMP RELAY
8	P	CAN-L
9	V	STARTER RELAY
10	B	GROUND

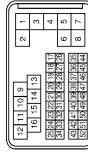

Connector No.	F12
Connector Name	WIRE TO WIRE
Connector Type	5AA36FB-RS8-SH28

Terminal No.	Color Of Wire	Signal Name [Specification]
1	R	-
2	GR	-
3	BG	-
4	R	-
5	G	-
7	L	-
8	W	-
9	W	-
10	BG	-
11	R	-

Connector No.	F100
Connector Name	TCM
Connector Type	SP10FG



Terminal No.	Color Of Wire	Signal Name [Specification]
1	-	IGNITION POWER SUPPLY
2	-	BATTERY POWER SUPPLY (MEMORY BACK-UP)
3	-	CAN-H
4	-	K-LINE
5	-	GROUND
6	-	IGNITION POWER SUPPLY
7	-	BACK-UP LAMP RELAY
8	-	CAN-L
9	-	STARTER RELAY
10	-	GROUND

Connector No.	M1
Connector Name	INTEGRAL SWITCH
Connector Type	TH24FW-NH



Terminal No.	Color Of Wire	Signal Name [Specification]
2	R	ILLUMINATION SIGNAL
3	LG	AV COMMUNICATION SIGNAL [L]
4	S8	AV COMMUNICATION SIGNAL [H]
7	W/B	DISK EJECT SIGNAL
8	G	HAZARD SIGNAL
13	B	GROUND
14	S8	ACC POWER SUPPLY [With 2.0L turbo gasoline engine]
14	V	ACC POWER SUPPLY [With VR30 engine]
15	B	ILLUMINATION CONTROL SIGNAL
16	BG	DISK EJECT SIGNAL GROUND

# AROUND VIEW MONITOR SYSTEM

## [AROUND VIEW MONITOR SYSTEM]

< WIRING DIAGRAM >

### AROUND VIEW MONITOR SYSTEM (VR ENGINE)

18	R	IGNITION SIGNAL (With VR30 engine)
18	W	IGNITION SIGNAL (With 2.0L turbo gasoline engine)
19	BR	CAMERA SWITCH SIGNAL

Connector No.	M12
Connector Name	INTEGRAL SWITCH
Connector Type	Typo_15540827-6



Terminal No.	Color Of Wire	Signal Name [Specification]
27	W	LVDS (+)
28	B	LVDS (-)
29	SHIELD	SHIELD

Connector No.	M3
Connector Name	INTEGRAL SWITCH
Connector Type	TH12FW-NH

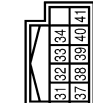

Terminal No.	Color Of Wire	Signal Name [Specification]
30	BR	ILLUMINATION SIGNAL (MULTIFUNCTION SWITCH)
31	W	GROUND (MULTIFUNCTION SWITCH)
32	R	ENCD-B SIGNAL
33	R	PUSH SWITCH A SIGNAL
34	W	PUSH SWITCH C SIGNAL
36	V	ILLUMINATION CONTROL SIGNAL (MULTIFUNCTION SWITCH)
37	W	ENCD-A SIGNAL
38	G	SELECT SWITCH SIGNAL
39	B	PUSH SWITCH B SIGNAL
40	B	SHIELD
41	L	L/R DETECTION SIGNAL

Connector No.	M14
Connector Name	BCM (BODY CONTROL MODULE)
Connector Type	TH40FE-NH

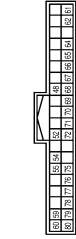

Terminal No.	Color Of Wire	Signal Name [Specification]
48	R	PUSH-BTN IGN SW LL PWR
52	G	DONGLE LINK
54	V	COMM LINE
55	R	RAIN SENSOR
59	P	CAN-L
60	L	CAN-H
61	G	REAR WINDOW DEF RLY CONT
62	R	STARTER RLY CONT
64	V	I-KEY WARN BUZZER
65	B	OUTS HD LAMP CONT
66	B	BLOWER FAN RLY CONT (With VR30 engine)
66	Y	BLOWER FAN RLY CONT (With 2.0L turbo gasoline engine)
67	W/B	IGN RLYAY (F/B) CONT
68	R	DIMMER
69	GR	A/T SHIFT SELECT PWR SPLY
70	B	IGN RLYAY (PDM/E/R) CONT
71	G	DR DOOR REQ SW
72	SB	PASS DOOR REQ SW
75	BR	COMBI SW INPUT 5
76	BG	COMBI SW INPUT 4
77	V	COMBI SW INPUT 3
78	Y	COMBI SW INPUT 2
79	LG	COMBI SW INPUT 1
80	L	TR LED OPNRS SW

Connector No.	M19
Connector Name	WIRE TO WIRE
Connector Type	TH80AW-CS16-TM4



Terminal No.	Color Of Wire	Signal Name [Specification]
1	Y	-
2	G	-
3	SB	-
5	Y	-
7	W	-
10	BG	-
11	BR	-
12	LG	-
13	GR	-
14	R	-
15	L	-
16	V	-
18	W	-
19	BR	-
20	W	-
24	R	- [With 2.0L turbo gasoline engine]
24	Y	- [With VR30 engine]
25	P	- [With 2.0L turbo gasoline engine]
26	G	- [With VR30 engine]
91	GR	-
93	GR	-
94	GR	-
96	W	-
98	BR	- [With VR30 engine and with BOSE system]
98	Y	- [Except with VR30 engine and with BOSE system]

50	W	-
51	Y	-
52	V	-
53	LG	-
54	R	-
55	R	-
58	V	-
59	BG	-
60	G	-
61	C	-
62	BG	-
63	BR	-
64	Y	-
70	LG	-
71	W	-
72	B	-
73	W	-
74	L	-
75	W	-
76	BR	-
77	B	-
78	SB	-
79	W	-
81	B	-
82	R	-
83	BG	-
84	L	-
85	W	-
86	B	-
88	G	-
89	V	-
91	GR	-
93	GR	-
94	GR	-
96	W	-
98	BR	- [With VR30 engine and with BOSE system]
98	Y	- [Except with VR30 engine and with BOSE system]

A  
B  
C  
D  
E  
F  
G  
H  
I  
J  
K  
L  
M  
N  
O  
P

AV

# AROUND VIEW MONITOR SYSTEM

< WIRING DIAGRAM >

[AROUND VIEW MONITOR SYSTEM]

## AROUND VIEW MONITOR SYSTEM (VR ENGINE)

Connector No.	M20
Connector Name	WIRE TO WIRE
Connector Type	TH16MW-AH



Connector No.	M22
Connector Name	WIRE TO WIRE
Connector Type	TH80MW-C516-TM4



Terminal No.	Wire	Signal Name [Specification]
7	W	-
8	L	-
10	Y	-
11	SHIELD	-
12	B	-
13	W	-
14	R	-

Connector No.	M21
Connector Name	WIRE TO WIRE
Connector Type	TH24MW-AH



Terminal No.	Wire	Signal Name [Specification]
1	V	-
2	P	-
3	LG	-
4	SHIELD	-
5	GR	-
7	L	-
8	R	-
9	G	-
10	SHIELD	-
11	W	-
12	SB	-
13	W	-
14	G	-

15	R	-
16	SHIELD	-
17	B	-
21	Y	-

Connector No.	M22
Connector Name	WIRE TO WIRE
Connector Type	TH80MW-C516-TM4



Terminal No.	Wire	Signal Name [Specification]
1	LG	-
2	L	-
3	SHIELD	-
3	BR	- [With VR30 engine]
3	R	- [With 2.0L turbo gasoline engine]
4	SHIELD	-
4	Y	- [With VR30 engine]
4	P	- [With 2.0L turbo gasoline engine]
5	G	-
5	V	- [With VR30 engine]
6	BG	- [With 2.0L turbo gasoline engine]
6	BR	- [With VR30 engine]
7	LG	-
7	P	- [With VR30 engine]
8	G	- [With 2.0L turbo gasoline engine]
8	P	- [With VR30 engine]
9	LG	- [With 2.0L turbo gasoline engine]
9	SHIELD	- [With VR30 engine]
10	V	-
11	GR	-
12	V	-
13	LG	-
14	LG	-
15	BR	- [With 2.0L turbo gasoline engine]
15	P	- [With VR30 engine]
16	SB	- [With DCM]
16	V	- [Without DCM]
17	Y	-
18	L	-
19	G	-
20	GR	-

58	LG	-
59	BR	-
60	BR	- [With 2.0L turbo gasoline engine]
61	L	- [With VR30 engine]
61	R	- [With 2.0L turbo gasoline engine]
62	P	- [With VR30 engine]
62	V	- [With 2.0L turbo gasoline engine]
63	L	-
64	W	-
65	R	-
66	L	- [With 2.0L turbo gasoline engine]
66	R	- [With VR30 engine]
67	G	-
68	L	-
69	P	-
71	GR	- [With 2.0L turbo gasoline engine]
71	R	- [With VR30 engine]
72	G	-
72	V	- [With 2.0L turbo gasoline engine]
73	LG	- [With VR30 engine]
74	L	-
74	LG	- [With 2.0L turbo gasoline engine]
75	P	-
76	SB	- [With 2.0L turbo gasoline engine]
76	V	- [With VR30 engine]
77	Y	-
78	L	-
79	G	-
80	GR	- [With 2.0L turbo gasoline engine]
80	W	- [With VR30 engine]
81	B	- [With 2.0L turbo gasoline engine]
81	R	- [With 2.0L turbo gasoline engine]
82	G	- [With 2.0L turbo gasoline engine]
82	SHIELD	- [With VR30 engine]
83	R	- [With 2.0L turbo gasoline engine]
83	W	- [With VR30 engine]
84	BR	- [With VR30 engine]
84	SHIELD	- [With 2.0L turbo gasoline engine]
85	BR	- [With VR30 engine]
85	G	- [With 2.0L turbo gasoline engine]
86	R	-
87	LG	- [With VR30 engine]
87	SHIELD	- [With 2.0L turbo gasoline engine]
88	R	-
89	LG	-
90	SB	-
92	L	- [With 2.0L turbo gasoline engine]
92	W	- [With VR30 engine]
93	SHIELD	-

21	R	-
23	L	-
24	BG	- [With 2.0L turbo gasoline engine]
24	V	- [With VR30 engine]
25	L	- [With 2.0L turbo gasoline engine]
25	SB	- [With VR30 engine]
26	G	- [With VR30 engine]
26	W	- [With 2.0L turbo gasoline engine]
27	R	-
28	R	-
29	LG	-
30	SB	- [With VR30 engine]
30	W	- [With 2.0L turbo gasoline engine]
31	SHIELD	-
32	L	-
33	B	- [With VR30 engine]
33	LG	- [With 2.0L turbo gasoline engine]
34	SHIELD	-
35	LG	- [With VR30 engine]
35	W	- [With 2.0L turbo gasoline engine]
36	R	-
37	R	-
37	V	- [With VR30 engine]
38	L	- [With 2.0L turbo gasoline engine]
38	W	- [With 2.0L turbo gasoline engine and without BOSE system]
39	P	- [With VR30 engine and without BOSE system]
39	R	- [With 2.0L turbo gasoline engine]
39	V	- [With VR30 engine and with BOSE system]
40	G	-
41	L	-
42	R	-
43	SHIELD	-
44	P	-
45	B	- [With 2.0L turbo gasoline engine]
45	G	- [With VR30 engine]
46	SHIELD	-
47	G	-
48	BG	- [With VR30 engine and with BOSE system]
48	BR	- [With 2.0L turbo gasoline engine and without BOSE system]
48	SB	- [With VR30 engine and without BOSE system]
49	G	-
51	L	- [With VR30 engine]
51	V	- [With 2.0L turbo gasoline engine]
52	L	- [With 2.0L turbo gasoline engine]
52	Y	- [With VR30 engine]
53	R	-
54	GR	-
55	L	-
56	P	-
57	R	-

# AROUND VIEW MONITOR SYSTEM

## [AROUND VIEW MONITOR SYSTEM]

< WIRING DIAGRAM >

### AROUND VIEW MONITOR SYSTEM (VR ENGINE)

Terminal No.	Color Of Wire	Signal Name [Specification]
94	R	-
95	L	- [With 2.0L turbo gasoline engine]
96	Y	- [With VR30 engine]
97	W	-
97	L	- [With VR30 engine]
97	R	- [With 2.0L turbo gasoline engine]
98	BR	- [With VR30 engine and with BOSE system]
99	P	- [With 2.0L turbo gasoline engine]
99	Y	- [With VR30 engine and without BOSE system]
100	BR	- [With VR30 engine]
100	W	- [With 2.0L turbo gasoline engine]

Connector No.	M24
Connector Name	CAN GATEWAY
Connector Type	TH12PW-NH

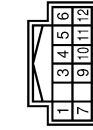

Terminal No.	Color Of Wire	Signal Name [Specification]
1	L	CAN-H (CAN COMMUNICATION CIRCUIT 1)
3	W	BATTERY POWER SUPPLY
4	L	CAN-H (CAN COMMUNICATION CIRCUIT 2)
5	B	GROUND
6	L	CAN-H (CAN COMMUNICATION CIRCUIT 2)
7	P	CAN-L (CAN COMMUNICATION CIRCUIT 1)
9	R	IGNITION POWER SUPPLY [With VR30 engine]
9	W	IGNITION POWER SUPPLY [With 2.0L turbo gasoline engine]
10	R	CAN-L (CAN COMMUNICATION CIRCUIT 2)
11	B	GROUND
12	R	CAN-L (CAN COMMUNICATION CIRCUIT 2)

Connector No.	M25
Connector Name	DATA LINK CONNECTOR
Connector Type	BD16FAW

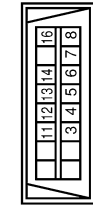

Terminal No.	Color Of Wire	Signal Name [Specification]
3	LG	M_CAN_L
4	B	EARTH
5	B	EARTH
6	L	CAN-H
7	V	KLINE [With 2.0L turbo gasoline engine]
7	W	KLINE [With VR30 engine]
8	W	IGN_SW
11	SB	M_CAN_H
12	R	CAN-L
13	L	CAN-H
14	P	CAN-L
16	W	POWER

Connector No.	M33
Connector Name	WIRE TO WIRE
Connector Type	NH60MW-TS12

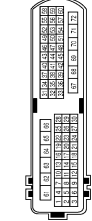

Terminal No.	Color Of Wire	Signal Name [Specification]
6	R	-
8	GR	-
9	GR	-
10	W	-
11	SHIELD	-
12	P	-
13	SB	-
14	LG	-

Terminal No.	Color Of Wire	Signal Name [Specification]
15	Y	-
16	P	-
17	W/B	-
18	W/B	-
19	LG	- [With DRPO]
19	V	- [Without DRPO]
20	V	-
21	B	-
22	BG	- [Without DRPO]
22	G	- [With DRPO]
23	L	-
24	Y	-
25	BG	- [Without DRPO]
25	L	- [With DRPO]
27	GR	-
28	V	-
29	B	-
30	W	-
31	B	-
32	SB	-
33	L	-
34	BR	-
35	LG	-
36	W	-
37	B	-
38	R	-
39	B	-
40	P	-
41	SB	-
43	W	- [With 2.0L turbo gasoline engine]
43	Y	- [With VR30 engine]
44	BG	-
46	BR	-
47	G	-
49	V	-
50	B	-
52	BR	-
53	B	-
54	B	-
55	BG	-
56	LG	-
57	V	-
58	R	-
59	G	-
60	L	-
61	G	-
62	R	-
63	V	-
64	B	-
65	R	-

65	BR	-
68	P	-
69	V	-
70	W	-
71	LG	-
72	V	-

Connector No.	M24
Connector Name	WIRE TO WIRE
Connector Type	NH60MW-TS12

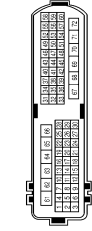

Terminal No.	Color Of Wire	Signal Name [Specification]
1	V	-
2	R	-
5	L	-
6	R	-
8	W	-
9	GR	-
10	V	-
11	Y	-
13	LG	-
16	G	-
17	B	-
18	W	-
19	B	-
20	SB	- [With DRPO]
20	Y	- [Without DRPO]
31	SHIELD	-
32	B	-
33	BG	- [Without DRPO]
23	P	- [With DRPO]
24	G	-
25	LG	-
26	BG	- [Without DRPO]
26	BR	- [With DRPO]
27	R	-
28	SB	-
29	BG	- [Without DRPO]
29	W/B	- [With DRPO]
30	L	-

A  
B  
C  
D  
E  
F  
G  
H  
I  
J  
K  
L  
M  
N  
O  
P

AV

# AROUND VIEW MONITOR SYSTEM

< WIRING DIAGRAM >

[AROUND VIEW MONITOR SYSTEM]

## AROUND VIEW MONITOR SYSTEM (VR ENGINE)

Terminal No.	Color Of Wire	Signal Name [Specification]
1	W/B	-
2	SB	-
3	L	-
4	P	- [Without Gateway]
5	BR	- [With Gateway]
6	SB	-
7	L	-
8	W	-
9	P	- [Without BOSE system]
10	V	- [With BOSE system]
11	SB	-
12	G	-
13	G	-

Connector No.	M39
Connector Name	WIRE TO WIRE
Connector Type	TH32FW-NH



1	2	3	4	5	6	7	8	9	10	11	12	13	14	15	16	17
---	---	---	---	---	---	---	---	---	----	----	----	----	----	----	----	----

Terminal No.	Color Of Wire	Signal Name [Specification]
15	R	-
16	SB	-
17	SHIELD	-
18	B	- [With VR30 engine]
19	W	-
20	Y	-
21	L	-
22	G	-
23	R	-
24	BR	-
25	Y	-
26	V	-
27	LG	-
28	BR	-
29	W/B	-
30	Y	-
31	W	-
32	LG	-

Connector No.	M40
Connector Name	WIRE TO WIRE
Connector Type	TH80MW-CS16-TM4



1	2	3	4	5	6	7	8	9	10	11	12	13	14	15	16	17
---	---	---	---	---	---	---	---	---	----	----	----	----	----	----	----	----

Terminal No.	Color Of Wire	Signal Name [Specification]
16	BR	- [With 2.0L turbo gasoline engine]
17	LG	-
18	B	- [With VR30 engine]
19	W/B	- [With 2.0L turbo gasoline engine]
20	Y	-
21	W	-
22	G	- [With 2.0L turbo gasoline engine]
23	V	- [With VR30 engine]
24	L	- [With 2.0L turbo gasoline engine]
25	B	- [With VR30 engine]
26	R	- [With 2.0L turbo gasoline engine]
27	P	-
28	BG	-
29	G	-
30	B	- [With VR30 engine]
31	L	- [With 2.0L turbo gasoline engine]
32	L	- [With VR30 engine]
33	R	- [With 2.0L turbo gasoline engine]
34	R	- [With 2.0L turbo gasoline engine]
35	R	- [With 2.0L turbo gasoline engine]
36	Y	- [With VR30 engine]
37	G	-
38	L	- [With 2.0L turbo gasoline engine]
39	R	- [With VR30 engine]
40	R	- [With 2.0L turbo gasoline engine]
41	Y	- [With VR30 engine]
42	GR	-
43	L	-
44	L	- [With 2.0L turbo gasoline engine]
45	W	- [With VR30 engine]
46	G	-
47	Y	- [With 2.0L turbo gasoline engine]
48	BG	- [With VR30 engine]
49	R	- [With VR30 engine]
50	SHIELD	-
51	B	- [With 2.0L turbo gasoline engine]
52	B	- [With VR30 engine]
53	L	-
54	W	-
55	S8	- [With 2.0L turbo gasoline engine]
56	Y	- [With VR30 engine]
57	B	- [With 2.0L turbo gasoline engine]
58	P	- [With VR30 engine]
59	BG	- [With 2.0L turbo gasoline engine]
60	GR	- [With VR30 engine]
61	Y	- [With VR30 engine]
62	B	- [With 2.0L turbo gasoline engine]
63	W/B	-
64	Y	-
65	R	-
66	Y	-
67	LG	-
68	BG	-
69	L	-

Terminal No.	Color Of Wire	Signal Name [Specification]
70	R	-
71	V	- [With VR30 engine]
72	L	- [With 2.0L turbo gasoline engine]
73	LG	- [With VR30 engine]
74	R	- [With VR30 engine]
75	W	- [With 2.0L turbo gasoline engine]
76	BR	- [With VR30 engine]
77	L	- [With 2.0L turbo gasoline engine]
78	B	- [With VR30 engine]
79	R	- [With 2.0L turbo gasoline engine]
80	B	-
81	G	- [With VR30 engine]
82	R	- [With 2.0L turbo gasoline engine]
83	LG	-
84	BR	- [With 2.0L turbo gasoline engine]
85	R	- [With VR30 engine]
86	V	-
87	G	-
88	R	-
89	V	-
90	G	- [With VR30 engine]
91	V	- [With 2.0L turbo gasoline engine]
92	W	- [With VR30 engine]
93	G	- [With 2.0L turbo gasoline engine]
94	BR	- [With VR30 engine]
95	GR	- [With 2.0L turbo gasoline engine]
96	L	- [With VR30 engine]
97	BR	- [With 2.0L turbo gasoline engine]
98	W	-
99	LG	-
100	Y	-
101	BR	- [With VR30 engine]
102	LG	- [With 2.0L turbo gasoline engine]
103	SHIELD	-

# AROUND VIEW MONITOR SYSTEM

< WIRING DIAGRAM >

[AROUND VIEW MONITOR SYSTEM]

## AROUND VIEW MONITOR SYSTEM (VR ENGINE)

Connector No.	M55
Connector Name	MULTIFUNCTION SWITCH
Connector Type	TH12FW-NH

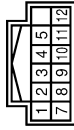

Terminal No.	Color Of Wire	Signal Name [Specification]
1	BR	ILL
2	W	GND
3	R	ENCD-B SIGNAL
4	R	PUSH SWITCH A SIGNAL
5	W	PUSH SWITCH C SIGNAL
7	V	ILLUMINATION CONTROL SIGNAL
8	W	ENCD-A SIGNAL
9	G	SELECT SWITCH SIGNAL
10	B	PUSH SWITCH B SIGNAL
11	B	SHIELD
12	L	L/R DETECTION SIGNAL

Connector No.	M76
Connector Name	SOMAR CONTROL UNIT
Connector Type	TH24FW-NH

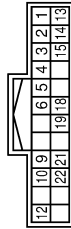

Terminal No.	Color Of Wire	Signal Name [Specification]
1	SB	CENTER SENSOR SIGNAL FRONT RH
2	LG	CORNER SENSOR SIGNAL FRONT LH
3	W	CORNER SENSOR SIGNAL FRONT RH
4	GR	CORNER SENSOR SIGNAL FRONT LH
5	L	CAN-H
6	P	CAN-L [Without CAN gateway]
6	R	CAN-L [With CAN gateway]
9	G	CENTER SENSOR SIGNAL REAR RH
10	BG	CORNER SENSOR SIGNAL REAR RH

12	R	IGNITION POWER SUPPLY [With VR30 engine]
12	W	Ignition Power Supply [With 2.0L turbo gasoline engine]
13	B	FRONT SENSOR GROUND
14	B	REAR SENSOR GROUND
15	B	GROUND
18	GR	FRONT BUZZER DRIVE SIGNAL
19	P	BUZZER POWER SUPPLY
21	BR	CENTER SENSOR SIGNAL REAR LH
22	W	CORNER SENSOR SIGNAL REAR LH

Connector No.	M77
Connector Name	STEERING ANGLE SENSOR
Connector Type	TH08FW-NH



Terminal No.	Color Of Wire	Signal Name [Specification]
1	B	GROUND
2	P	CAN-L [Without Gateway]
2	R	CAN-L [With Gateway]
4	G	IGN
5	L	CAN-H

Connector No.	M97
Connector Name	BACK-UP LAMP RELAY
Connector Type	RAS02FL-M2-C



Terminal No.	Color Of Wire	Signal Name [Specification]
1	R	-
2	SB	- [With 2.0L turbo gasoline engine]
2	W	- [With VR30 engine]
3	R	-

5	BR	-
---	----	---

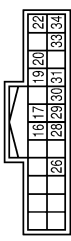

Terminal No.	Color Of Wire	Signal Name [Specification]
16	LG	AV COMMUNICATION SIGNAL (L)
17	P	CAN-L
19	R	DIMMER SIGNAL
20	BR	REVERSE SIGNAL
22	B	GROUND
26	BR	CAMERA SWITCH SIGNAL
28	SB	AV COMMUNICATION SIGNAL (H)
29	L	CAN-H
30	R	IGNITION SIGNAL [With VR30 engine]
30	W	IGNITION SIGNAL [With 2.0L turbo gasoline engine]
31	R	VEHICLE SPEED SIGNAL (R-PULSE)
33	SB	ACC POWER SUPPLY
34	Y	BATTERY POWER SUPPLY

Connector No.	M101
Connector Name	DISPLAY CONTROL UNIT
Connector Type	TH40FW-NH



Terminal No.	Color Of Wire	Signal Name [Specification]
36	LG	COMPOSITE IMAGE SIGNAL (-)
38	SHIELD	SHIELD
40	SHIELD	MANUFACTURER SPECIFIC SIGNAL
42	G	SOUND SIGNAL RH (-)

43	SHIELD	SHIELD
44	L	SOUND SIGNAL LH (-)
45	W	TEL VOICE SIGNAL (-)
46	SHIELD	SHIELD
47	R	VOICE GUIDANCE SIGNAL OUTPUT (-)
48	B	VOICE GUIDANCE SIGNAL INPUT (-)
49	W	NS ON/OFF SIGNAL
50	R	MICROPHONE SIGNAL GROUND [WITH NAVIGATION]
51	SHIELD	SHIELD
52	SHIELD	MICROPHONE SIGNAL GROUND
54	W	CAMERA POWER SUPPLY GROUND
55	SHIELD	SHIELD
56	BR	COMPOSITE IMAGE SIGNAL (+)
58	B	CAMERA IMAGE SIGNAL
60	W	SOUND SIGNAL (-)
61	B	SOUND SIGNAL RH (+)
62	R	SHIELD
63	SHIELD	SHIELD
64	V	SOUND SIGNAL LH (+)
65	B	TEL VOICE SIGNAL (+)
66	SHIELD	SHIELD
67	G	VOICE GUIDANCE SIGNAL OUTPUT (+)
68	W	VOICE GUIDANCE SIGNAL INPUT (+)
69	SHIELD	SHIELD
70	G	MICROPHONE SIGNAL (NAV)
71	G	MICROPHONE SIGNAL [Without telematics system]
71	R	MICROPHONE SIGNAL [With telematics system]
72	L	MICROPHONE VCC
74	R	CAMERA POWER SUPPLY

Connector No.	M105
Connector Name	DISPLAY CONTROL UNIT
Connector Type	Type_1554887-6



Terminal No.	Color Of Wire	Signal Name [Specification]
92	W	LVDS (+)
93	B	LVDS (-)
94	SHIELD	SHIELD

A  
B  
C  
D  
E  
F  
G  
H  
I  
J  
K  
L  
M  
N  
O  
P

AV

# AROUND VIEW MONITOR SYSTEM

## [AROUND VIEW MONITOR SYSTEM]

< WIRING DIAGRAM >

### AROUND VIEW MONITOR SYSTEM (VR ENGINE)

Connector No.	M110
Connector Name	BUZZER
Connector Type	TH04FW-AH



Connector No.	M133
Connector Name	FUSE BLOCK (J/B)
Connector Type	TH40FW-AH

Terminal No.	Color Of Wire	Signal Name [Specification]
1	P	-
2	P	-
3	GR	-

Connector No.	M132
Connector Name	FUSE BLOCK (J/B)
Connector Type	NS16FW-CS



Terminal No.	Color Of Wire	Signal Name [Specification]
118	LG	-
138	P	-
148	G	-
158	Y	-
168	Y	-
28	B	-
48	W	-
58	R	-
98	Y	-

6C	G	-
7C	G	-
8C	G	-
9C	V	-

Connector No.	M135
Connector Name	JOINT CONNECTOR-M09
Connector Type	24342_4G2A

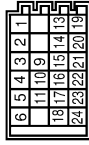

Terminal No.	Color Of Wire	Signal Name [Specification]
1	B	-
2	B	-
3	B	-
4	B	-
5	B	-
6	B	-
9	LG	-
10	LG	-
11	LG	- [With VR30 engine]
13	B	- [With 2.0L turbo gasoline engine]
14	B	- [With VR30 engine]
15	B	- [With 2.0L turbo gasoline engine]
16	SB	- [With VR30 engine]
17	SB	- [With 2.0L turbo gasoline engine]
18	SB	- [With VR30 engine]
19	SHIELD	- [With VR30 engine]
20	R	-
21	R	-
22	SHIELD	-
23	L	-
24	L	-

Connector No.	M137
Connector Name	JOINT CONNECTOR-M10
Connector Type	24342_4G2A

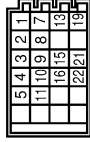

Terminal No.	Color Of Wire	Signal Name [Specification]
1	B	-
2	B	-
3	B	-
4	B	-
5	B	-
7	B	-
8	B	-
9	B	-
10	B	-
11	B	-
13	L	-
15	L	-
16	L	-
19	R	-
21	R	-
22	R	-

Connector No.	M144
Connector Name	TCU
Connector Type	TH40FB-AH



Terminal No.	Color Of Wire	Signal Name [Specification]
1	Y	BATTERY POWER SUPPLY
2	SB	ACC POWER SUPPLY [With 2.0L turbo gasoline engine]
2	V	ACC POWER SUPPLY [With VR30 engine]
3	SB	ACC OUTPUT

JRNWF7528GB

# AROUND VIEW MONITOR SYSTEM

## [AROUND VIEW MONITOR SYSTEM]

< WIRING DIAGRAM >

### AROUND VIEW MONITOR SYSTEM (VR ENGINE)

5	BR	SOS SWITCH LED SIGNAL
6	L	CAN-L
7	P	CAN-R
10	R	IGNITION SIGNAL (With VR30 engine)
10	W	IGNITION SIGNAL (With 2.0L turbo gasoline engine)
11	W	IGNITION SIGNAL (With 2.0L turbo gasoline engine)
12	R	MICROPHONE SIGNAL
12	R	MICROPHONE SIGNAL
16	SHIELD	SHIELD
17	G	MICROPHONE SIGNAL
18	L	MICROPHONE UCC
26	SB	AV COMMUNICATION SIGNAL (H)
27	LG	AV COMMUNICATION SIGNAL (L)
28	B	GROUND
29	B	GROUND
30	SHIELD	SHIELD
31	B	SOUND SIGNAL (+)
32	W	SOUND SIGNAL (-)
37	G	SOS CALL SWITCH SIGNAL

Connector No.	M171
Connector Name	JOINT CONNECTOR M01
Connector Type	24342_4GAZA

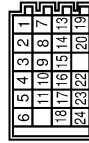

17	SB	- [With VR30 engine]
18	SB	- [With VR30 engine]
18	Y	- [With VR30 engine]
19	G	- [With 2.0L turbo gasoline engine]
20	G	-
22	LG	- [With VR30 engine]
23	SB	- [With 2.0L turbo gasoline engine]
23	LG	- [With VR30 engine]
23	SB	- [With 2.0L turbo gasoline engine]
24	G	- [With VR30 engine]
24	SB	- [With 2.0L turbo gasoline engine]

Connector No.	M173
Connector Name	JOINT CONNECTOR-M03
Connector Type	24342_4GAZA

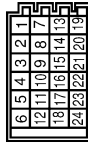

19	LG	- [With 2.0L turbo gasoline engine]
20	BR	- [With VR30 engine]
20	LG	- [With 2.0L turbo gasoline engine]
21	BR	- [With VR30 engine]
21	LG	- [With 2.0L turbo gasoline engine]
22	R	- [With 2.0L turbo gasoline engine]
22	SA	- [With VR30 engine]
23	B	- [With 2.0L turbo gasoline engine]
23	SA	- [With VR30 engine]
24	R	- [With 2.0L turbo gasoline engine]
24	SB	- [With VR30 engine]

Connector No.	M174
Connector Name	JOINT CONNECTOR-M04
Connector Type	24342_4GAZA

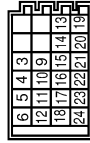

Terminal No.	Color Of Wire	Signal Name [Specification]
3	L	-
4	L	-
5	L	-
6	L	-
9	Y	-
10	Y	-
11	Y	-
12	Y	-
13	SA	-
14	SA	-
15	SB	-
16	SB	-
17	SB	-
18	SB	-
19	LG	-
20	LG	-
21	LG	-
22	LG	-
23	LG	-
24	LG	-

Connector No.	M175
Connector Name	JOINT CONNECTOR-M05
Connector Type	NH20FLDC

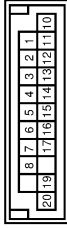

Terminal No.	Color Of Wire	Signal Name [Specification]
1	L	-
2	L	-
3	L	-
4	L	-
5	L	-
6	L	-
7	L	-
8	L	-
10	P	-
11	P	-
12	P	-
13	P	-
14	P	-
15	P	-
16	P	-
17	P	-
19	W	-
20	W	-

Connector No.	M177
Connector Name	JOINT CONNECTOR-M07
Connector Type	24342_4GAZA

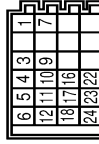

A  
B  
C  
D  
E  
F  
G  
H  
I  
J  
K  
L  
M  
N  
O  
P

AV

# AROUND VIEW MONITOR SYSTEM

## [AROUND VIEW MONITOR SYSTEM]

< WIRING DIAGRAM >

### AROUND VIEW MONITOR SYSTEM (VR ENGINE)

Terminal No.	Color Of Wire	Signal Name [Specification]
1	L	-
3	L	-
4	L	-
5	L	-
6	L	-
7	P	-
9	P	-
10	P	-
11	P	-
12	P	-
16	L	-
17	L	-
18	L	-
22	P	-
23	P	-
24	P	-

Connector No.	M178
Connector Name	JOINT CONNECTOR M08
Connector Type	NH20FW-DC

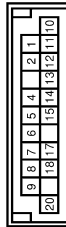

Terminal No.	Color Of Wire	Signal Name [Specification]
12	B	- [With VR30 engine]
13	W	- [With 2.0L turbo gasoline engine]
13	B	- [With VR30 engine]
14	W	- [With 2.0L turbo gasoline engine]
14	B	- [With VR30 engine]
15	W	- [With 2.0L turbo gasoline engine]
15	B	- [With VR30 engine]
17	BR	-
18	BR	-
20	BR	-

Connector No.	T48
Connector Name	WIRE TO WIRE
Connector Type	MS16FW-CS



Terminal No.	Color Of Wire	Signal Name [Specification]
1	Y	-
2	BG	-
4	L	-
5	P	-
6	G	-
8	B	-
9	R	-
10	P	-
11	L	-
13	G	- [With around view monitor]
13	L	- [With rear view monitor]
14	B	- [With rear view monitor]
14	R	- [With around view monitor]
15	B	- [With around view monitor]
15	W	- [With rear view monitor]
16	R	- [With rear view monitor]
16	W	- [With around view monitor]

Connector No.	T50
Connector Name	REAR CAMERA
Connector Type	TH08MW-NH



Terminal No.	Color Of Wire	Signal Name [Specification]
1	SHIELD	-
4	G	-
5	R	-
7	B	-
8	W	-

JRNWF7530GB

## BASIC INSPECTION

### DIAGNOSIS AND REPAIR WORKFLOW

#### Work Flow

INFOID:000000013717491

#### OVERALL SEQUENCE

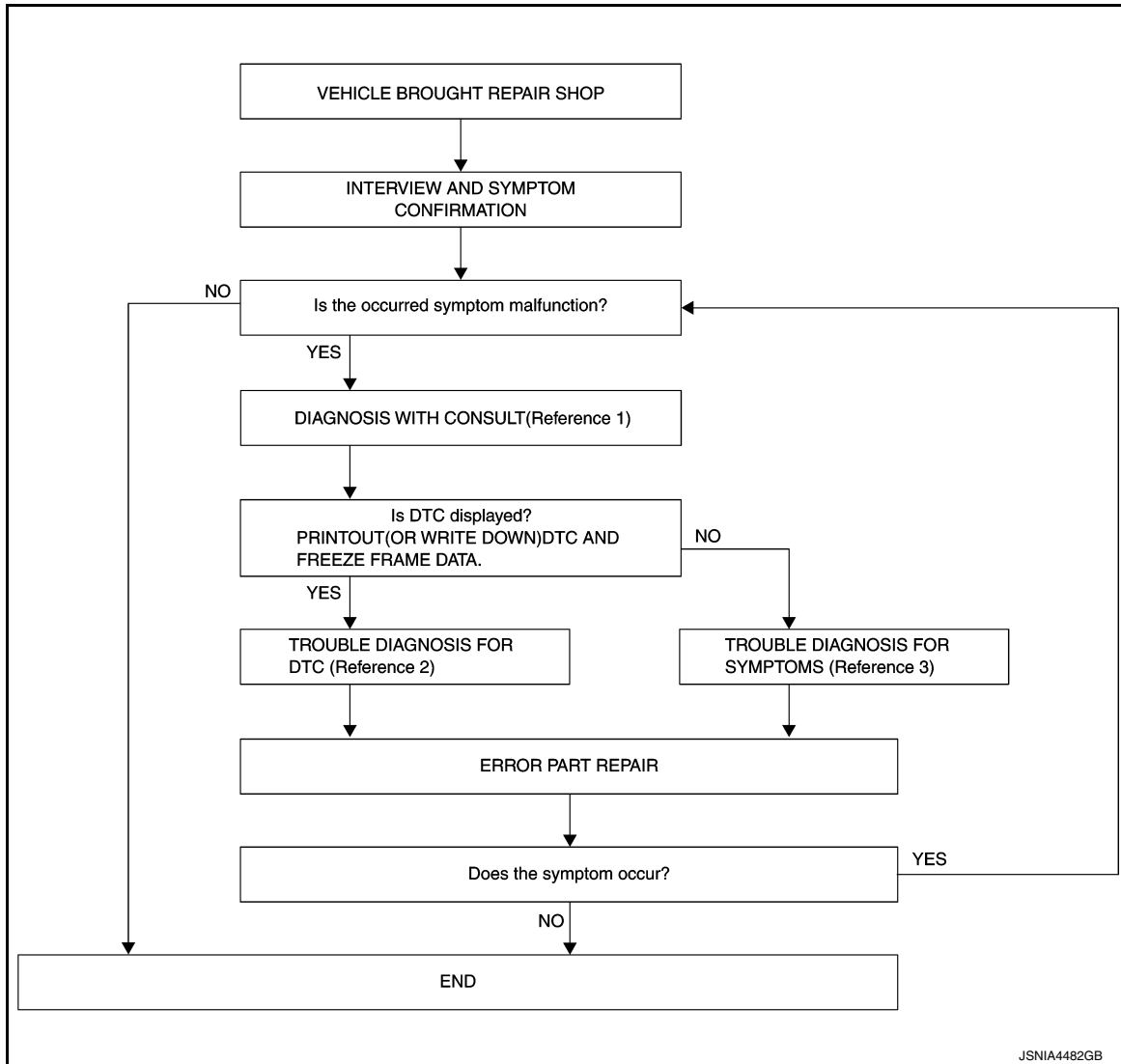

- Reference 1… Refer to [AV-487. "CONSULT Function"](#).
- Reference 2… Refer to [AV-512. "DTC Index"](#).
- Reference 3… Refer to [AV-644. "Symptom Table"](#).

#### DETAILED FLOW

##### 1. INTERVIEW AND SYMPTOM CONFIRMATION

Check the malfunction symptoms by performing the following items.

- Interview the customer to obtain the malfunction information (conditions and environment when the malfunction occurred).
- Check the symptom.

##### Is the occurred symptom malfunction?

YES >> GO TO 2.

NO >> INSPECTION END

##### 2. DIAGNOSIS WITH CONSULT

A  
B  
C  
D  
E  
F  
G  
H  
I  
J  
K  
L  
M

AV

O  
P

# DIAGNOSIS AND REPAIR WORKFLOW

[AROUND VIEW MONITOR SYSTEM]

< BASIC INSPECTION >

1. Connect CONSULT and perform a self-diagnosis for "MULTI AV". Refer to [AV-487. "CONSULT Function"](#).

**NOTE:**

Skip to step 4 of the diagnosis procedure if "MULTI AV" is not displayed.

2. When DTC is detected, follow the instructions below:
  - Record DTC and Freeze Frame Data.

Is DTC displayed?

YES >> GO TO 3.

NO >> GO TO 4.

## 3. TROUBLE DIAGNOSIS FOR DTC

---

1. Check the DTC indicated in the "Self-Diagnosis Results".
2. Perform the relevant diagnosis referring to the DTC Index. Refer to [AV-512. "DTC Index"](#).

>> GO TO 5.

## 4. TROUBLE DIAGNOSIS FOR SYMPTOMS

---

Perform the relevant diagnosis referring to the diagnosis chart by symptom. Refer to [AV-644. "Symptom Table"](#).

>> GO TO 5.

## 5. ERROR PART REPAIR

---

1. Repair or replace the identified malfunctioning parts.
2. Perform a self-diagnosis for "MULTI AV" with CONSULT.

**NOTE:**

Erase the stored self-diagnosis results after repairing or replacing the relevant components if any DTC has been indicated in the "Self-Diagnosis Results".

3. Check that the symptom does not occur.

Does the symptom occur?

YES >> GO TO 1.

NO >> INSPECTION END

# ADDITIONAL SERVICE WHEN REPLACING AROUND VIEW MONITOR CONTROL UNIT

< BASIC INSPECTION >

[AROUND VIEW MONITOR SYSTEM]

## ADDITIONAL SERVICE WHEN REPLACING AROUND VIEW MONITOR CONTROL UNIT

### Description

INFOID:000000013717492

Perform the following operations when replacing around view monitor control unit.

1. Configuration, refer to [AV-563, "Work Procedure"](#).
2. Calibrating camera image, refer to [AV-566, "Work Procedure"](#).

A  
B  
C  
D  
E  
F  
G  
H  
I  
J  
K  
L  
M  
N  
O  
P

AV

## ADDITIONAL SERVICE WHEN REPLACING SONAR CONTROL UNIT

< BASIC INSPECTION >

[AROUND VIEW MONITOR SYSTEM]

---

## ADDITIONAL SERVICE WHEN REPLACING SONAR CONTROL UNIT

### Description

INFOID:000000013717493

Perform the following operations when replacing sonar control unit.  
Configuration, refer to [AV-564, "Work Procedure"](#).

# CONFIGURATION (AROUND VIEW MONITOR CONTROL UNIT)

< BASIC INSPECTION >

[AROUND VIEW MONITOR SYSTEM]

## CONFIGURATION (AROUND VIEW MONITOR CONTROL UNIT)

### Work Procedure

INFOID:000000013717494

#### 1. SAVING VEHICLE SPECIFICATION

##### CONSULT Configuration

Perform "Before Replace ECU", and save the current vehicle specification in CONSULT.

Is the vehicle specification saved normally?

YES >> GO TO 2.

NO >> GO TO 4.

#### 2. REPLACE AROUND VIEW MONITOR CONTROL UNIT

Replace around view monitor control unit. Refer to [AV-647, "Removal and Installation"](#).

>> GO TO 3.

#### 3. WRITING VEHICLE SPECIFICATION

##### CONSULT Configuration

Select "Configuration" or "After Replace ECU", and write the vehicle specification saved in CONSULT to around view monitor control unit.

>> GO TO 6.

#### 4. REPLACE AROUND VIEW MONITOR CONTROL UNIT

Replace around view monitor control unit. Refer to [AV-647, "Removal and Installation"](#).

>> GO TO 5.

#### 5. WRITE VEHICLE SPECIFICATION

##### CONSULT Configuration

Select "Manual Configuration", and write the vehicle specification to around view monitor control unit.

##### NOTE:

Around view monitor control unit does not have any setting items. Selection of items on "Manual Configuration" screen is not required.

>> GO TO 6.

#### 6. PERFORM SELF-DIAGNOSIS

##### CONSULT Self Diagnostic Result

Perform self-diagnosis of CONSULT, and check whether or not DTC U1305 is detected.

Is DTC U1305 detected?

>> GO TO 5.

>> GO TO 7.

#### 7. OPERATION CHECK

Check that the operation of the around view monitor control unit and camera images (fixed guide lines and predictive course lines) are normal.

>> WORK END

A  
B  
C  
D  
E  
F  
G  
H  
I  
J  
K  
L  
M  
O  
P

AV

# CONFIGURATION (SONAR CONTROL UNIT)

< BASIC INSPECTION >

[AROUND VIEW MONITOR SYSTEM]

## CONFIGURATION (SONAR CONTROL UNIT)

### Work Procedure

INFOID:000000013717495

#### 1. SAVING VEHICLE SPECIFICATION

---

##### ④ CONSULT Configuration

Perform "Before Replace ECU", and save the current vehicle specification in CONSULT.

Is the vehicle specification saved normally?

YES >> GO TO 2.

NO >> GO TO 4.

#### 2. REPLACE SONAR CONTROL UNIT

---

Replace sonar control unit. Refer to [AV-652. "Removal and Installation"](#).

>> GO TO 3.

#### 3. WRITING VEHICLE SPECIFICATION

---

##### ④ CONSULT Configuration

Select "Configuration" or "After Replace ECU", and write the vehicle specification saved in CONSULT to sonar control unit.

>> GO TO 6.

#### 4. REPLACE SONAR CONTROL UNIT

---

Replace sonar control unit. Refer to [AV-652. "Removal and Installation"](#).

>> GO TO 5.

#### 5. WRITE VEHICLE SPECIFICATION

---

##### ④ CONSULT Configuration

Select "Manual Configuration", and write the vehicle specification to sonar control unit.

##### **NOTE:**

Sonar monitor control unit does not have any setting items. Selection of items on "Manual Configuration" screen is not required.

>> GO TO 6.

#### 6. PERFORM SELF-DIAGNOSIS

---

##### ④ CONSULT Self Diagnostic Result

Perform self-diagnosis of CONSULT, and check whether or not DTC B2724 is detected.

Is DTC B2724 detected?

>> GO TO 5.

>> GO TO 7.

#### 7. OPERATION CHECK

---

Check that the operation of the sonar control unit is normal.

>> WORK END

# PREDICTIVE COURSE LINE CENTER POSITION ADJUSTMENT

< BASIC INSPECTION >

[AROUND VIEW MONITOR SYSTEM]

## PREDICTIVE COURSE LINE CENTER POSITION ADJUSTMENT

### Description

INFOID:000000013717496

Adjust the center position of the predictive course line of the front view and rear view monitor. Refer to [AV-565](#).  
"Work Procedure".

### Work Procedure

INFOID:000000013717497

#### 1.DRIVING

Drive the vehicle straight ahead 100 m (328.1 ft) or more at a speed of 30 km/h (18.6 MPH) or more.

>> END

A  
B  
C  
D  
E  
F  
G  
H  
I  
J  
K  
L  
M  
O  
P

AV

# CALIBRATING CAMERA IMAGE (AROUND VIEW MONITOR)

< BASIC INSPECTION >

[AROUND VIEW MONITOR SYSTEM]

## CALIBRATING CAMERA IMAGE (AROUND VIEW MONITOR)

### Description

INFOID:000000013717498

- Perform camera calibration and perform writing to the around view monitor control unit, after removal/installation or replacement of each camera or camera mounting parts (front grille, door mirror, or others), or replacement of around view monitor control unit.
- By performing this camera calibration procedure, the boundary of each camera image is aligned to the white lines on the road near the vehicle. The boundary of each camera image may not be aligned to the white lines far from the vehicle. The farther the line, the greater the difference is.
- Following the flowchart shown in the figure, perform calibration.

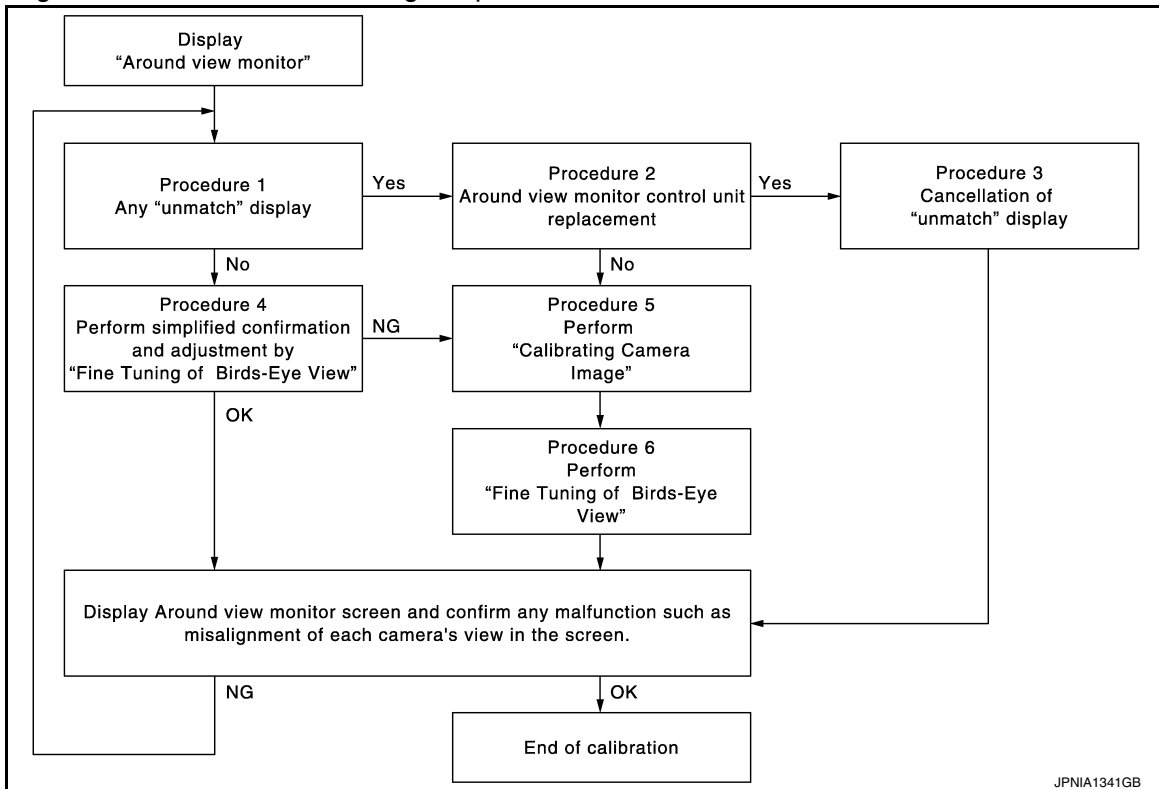

JPNIA1341GB

- For details of calibration operation, refer to [AV-566, "Work Procedure"](#).

### Work Procedure

INFOID:000000013717499

#### CAUTION:

When around view monitor control unit is replaced, perform the control unit setting before performing this calibration. Refer to [AV-566, "Description"](#).

#### 1. CHECK AROUND VIEW MONITOR SCREEN

Check whether or not un-match display "☒" is on screen.

Is un-match display on screen?

YES >> GO TO 2.

NO >> GO TO 4.

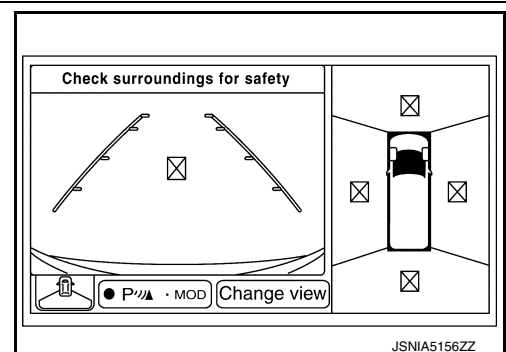

JSNIA5156ZZ

#### 2. CHECK WHETHER OR NOT AROUND VIEW MONITOR CONTROL UNIT IS REPLACED

Check whether or not around view monitor control unit is replaced.

Is around view monitor control unit replaced?

# CALIBRATING CAMERA IMAGE (AROUND VIEW MONITOR)

< BASIC INSPECTION >

[AROUND VIEW MONITOR SYSTEM]

- YES >> GO TO 3.
- NO >> GO TO 5.

## 3. RELEASE UN-MATCH DISPLAY (PERFORM ONLY WHEN AROUND VIEW MONITOR CONTROL UNIT IS REPLACED)

CONSULT work support

1. Select "CALIBRATING CAMERA IMAGE".

### NOTE:

In random order, perform the operation for all cameras for which un-match display  appears.

- Front camera: "CALIBRATING CAMERA IMAGE (FRONT CAMERA)"
  - Passenger side camera: "CALIBRATING CAMERA IMAGE (PASS-SIDE CAMERA)"
  - Driver side camera: "CALIBRATING CAMERA IMAGE (DR-SIDE CAMERA)"
  - Rear camera: "CALIBRATING CAMERA IMAGE (REAR CAMERA)"
2. On each camera calibration screen, press "APPLY" button, and then press "OK" button.

### CAUTION:

- Never perform any operation other than selecting "APPLY" button.
- Never perform "INITIALIZE CAMERA IMAGE CALIBRATION".

3. Display the around view monitor screen. Check that images are displayed normally without any difference between images for each camera.

Is there a malfunction such as a difference between camera images?

- YES >> Calibration end
- NO >> GO TO 1.

## 4. PERFORM SIMPLIFIED CONFIRMATION/ADJUSTMENT BY "FINE TUNING OF BIRDS-EYE VIEW"

1. Put target line 1 beside each axle using packing tape, etc.
2. Put target line 2 at a position approximately 30 cm (11.81 in) away from each side of the vehicle (the left and right). Check that the target line is a length equivalent to the vehicle length, plus an additional approximate length of 1.0 m (39.37 in) (in parallel with the vehicle as much as possible).

Preparation of simplified target line

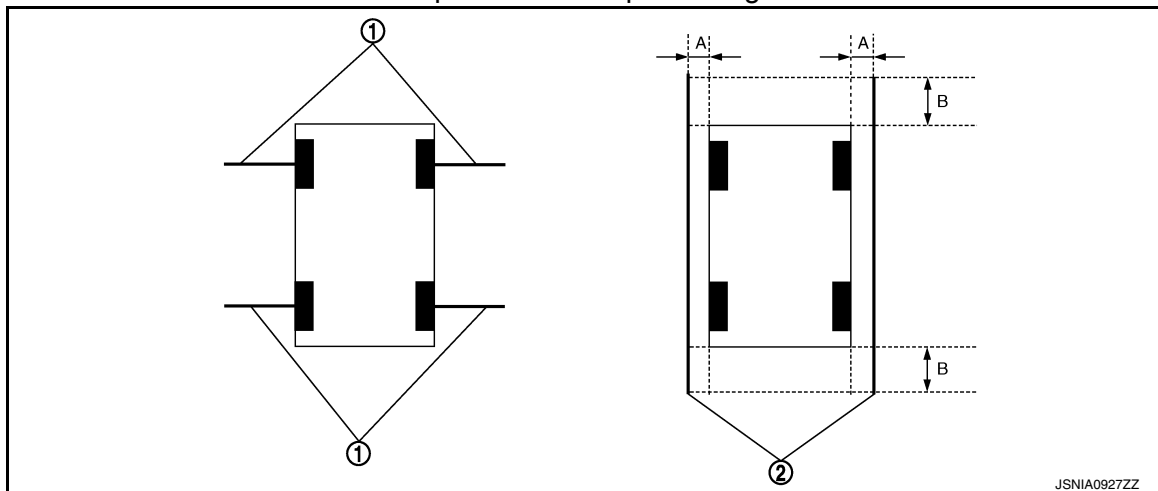

- ① Target lines 1
- ② Target lines 2
- A. Approx. 30 cm (11.81 in)
- B. Approx. 1.0 m (39.37 in)

CONSULT work support

Select "FINE TUNING OF BIRDS-EYE VIEW".

4. Select the left and right cameras on CONSULT screen. Perform the following calibration.
  - Check that target line 1 and marker are aligned normally on screen. If difference is detected, align marker using "+" and "-" of "AXIS X" and "AXIS Y" on CONSULT screen.
  - Check that target line 2 is aligned normally on screen without difference between images of each camera. If difference is detected, align images so that line 2 is displayed in a straight line using "+" and "-" of "AXIS X", "AXIS Y", and "ROTATE" on CONSULT screen.

### NOTE:

Press "SELECT" button on CONSULT screen and select camera position for adjustment.

### CAUTION:

A  
B  
C  
D  
E  
F  
G  
H  
I  
J  
K  
L  
M  
O  
P

AV

# CALIBRATING CAMERA IMAGE (AROUND VIEW MONITOR)

< BASIC INSPECTION >

[AROUND VIEW MONITOR SYSTEM]

- Never adjust the front camera and rear camera. Only adjust the side cameras LH/RH.
- Perform adjustment operation slowly because approximately 1 second is required for changing image on screen.

## Simplified target line adjustment method

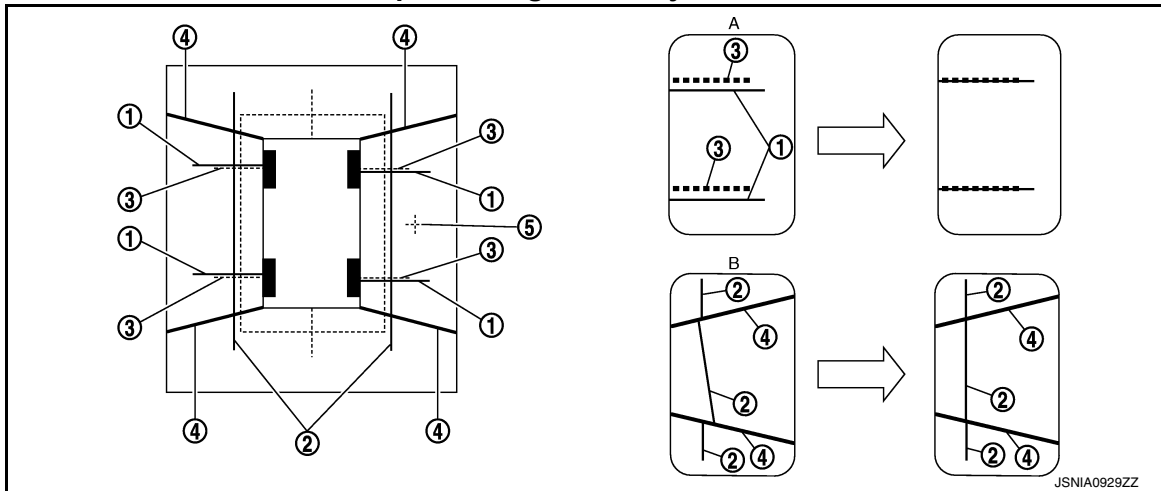

- ① Target lines 1                      ② Target lines 2                      ③ Marker for target line 1
- ④ Boundary between cameras       ⑤ Crosshair cursor (mark indicated the selected camera)
- A. Adjustment method for target lines 1 (right)    B. Adjustment method for target lines 2 (right)

5. Adjust the left and right cameras. Check that difference of images on screen between target line 1 and marker, and between target lines 2 are solved. Press “APPLY”.

**NOTE:**

- The setting can be initialized to factory default condition using “CALIBRATING CAMERA IMAGE” of work support.
- The adjustment value on this mode is cancelled when “INITIALIZE CAMERA IMAGE CALIBRATION” is performed.

Is the difference corrected?

YES >> • Select “OK” to end calibration.

**CAUTION:**

**After selecting “OK”, never perform any operation other than “BACK” on CONSULT.**

NO >> GO TO 5.

## 5.PERFORM “CALIBRATING CAMERA IMAGE”

Preparation of target line

1. Hang a string with a weight as shown in the figure. Put the points FM0, RM0 (mark) on the ground at the center of the vehicle front end and rear end using white packing tape or a pen.
2. Route the vinyl string under the vehicle, and then pull and fix the vinyl string at a point approximately 1.0 m (39.37 in) at the front and rear of the vehicle through points FM0 and RM0 using packing tape.

# CALIBRATING CAMERA IMAGE (AROUND VIEW MONITOR)

< BASIC INSPECTION >

[AROUND VIEW MONITOR SYSTEM]

## Target line preparation procedure 1

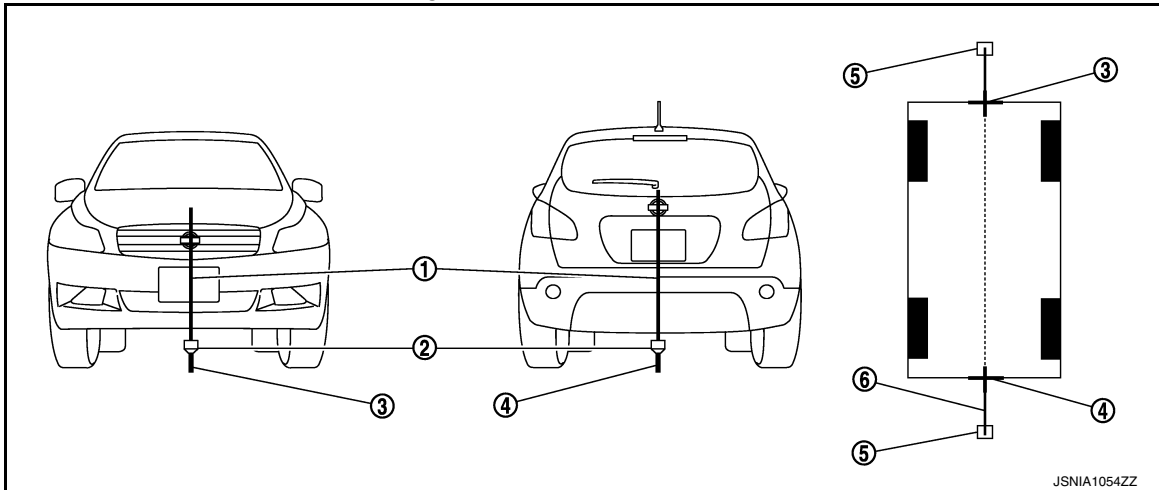

- ① Thread
- ② Weight
- ③ Point FM0 (mark)
- ④ Point RM0 (mark)
- ⑤ Packing tape (to fix the vinyl string)
- ⑥ Vinyl string

3. Put points FM and RM (mark) 75 cm (29.53 in) from the points FM0 and RM0 individually.
4. Route the vinyl string through points FM and RM using a triangle scale, and then fix it at approximately 1.5 m (59.06 in) on both sides with packing tape.
5. Put points FL, FR, RL, and RR (mark) at distance of a half the vehicle width, plus 30 cm (11.81 in) to the left and right from points FM and RM.

## Target line preparation procedure 2

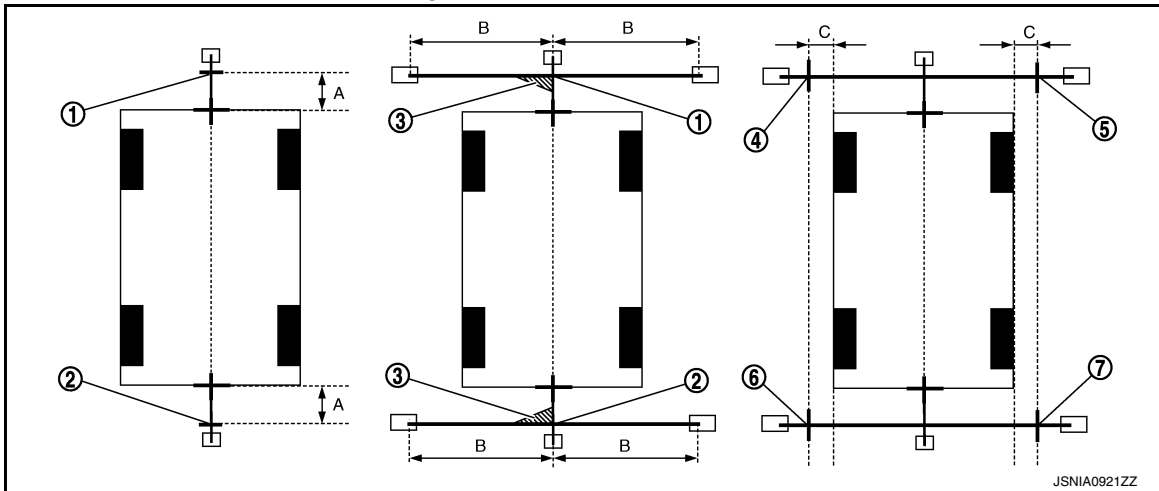

- ① Point FM
- ② Point RM
- ③ Triangle scale
- ④ Point FL (mark)
- ⑤ Point FR (mark)
- ⑥ Point RL (mark)
- ⑦ Point RR (mark)

- A. 75 cm (29.53 in)
- B. Approximately 1.5 m (59.06 in)
- C. 30 cm (11.81 in)  
[A half of the vehicle width plus 30 cm (11.81 in) from the points FM and RM]

6. Draw the lines of the points FL – RL and FR – RR with the vinyl string, and fix it with packing tape.
7. Put a mark at the center of front axle. Use a triangle ruler to draw a line at the position 1 m (39.37 in) backward from the mark placed at the center of front axle so that the line becomes perpendicular to the line drawn between point FL-RL and point FR-RR and fix with packing tape.
8. Put a mark at the center of rear axle. Use a triangle ruler to draw a line at the position 1 m backward from the mark placed at the center of front axle so that the line becomes perpendicular to the line drawn between point FL-RL and point FR-RR and fix with packing tape.

A  
B  
C  
D  
E  
F  
G  
H  
I  
J  
K  
L  
M

AV

O  
P

# CALIBRATING CAMERA IMAGE (AROUND VIEW MONITOR)

< BASIC INSPECTION >

[AROUND VIEW MONITOR SYSTEM]

## Target line preparation procedure 3

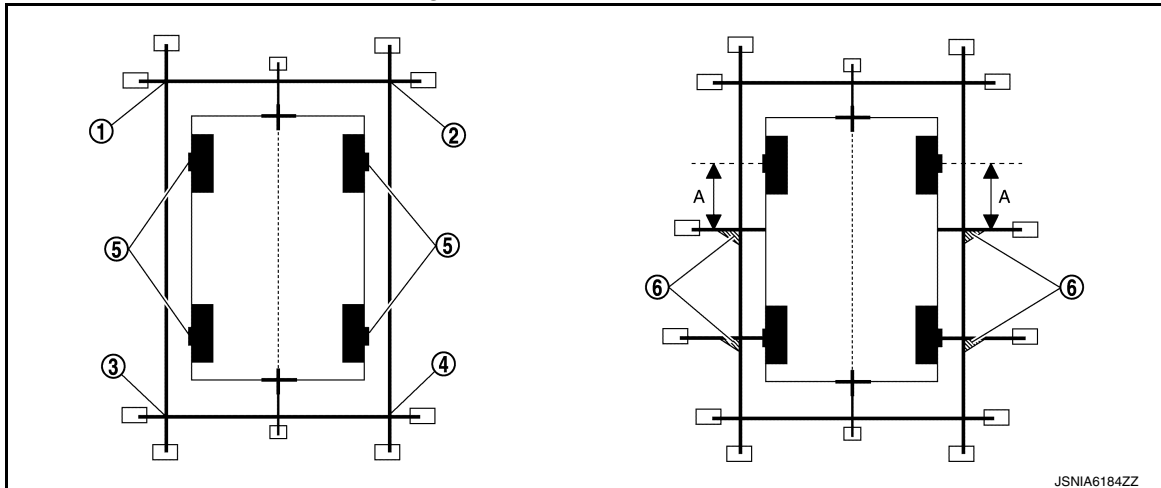

- ① Point FL                                      ② Point FR                                      ③ Point RL  
④ Point RR                                      ⑤ Center position of axle                      ⑥ Triangle scale  
A. 1 m (39.37 in)

Perform "CALIBRATING CAMERA IMAGE"

CONSULT work support

1. Select "CALIBRATING CAMERA IMAGE".

**NOTE:**

In random order, perform the operation for all cameras.

- Front camera: "CALIBRATING CAMERA IMAGE (FRONT CAMERA)"
  - Passenger side camera: "CALIBRATING CAMERA IMAGE (PASS-SIDE CAMERA)"
  - Driver side camera: "CALIBRATING CAMERA IMAGE (DR-SIDE CAMERA)"
  - Rear camera: "CALIBRATING CAMERA IMAGE (REAR CAMERA)"
2. On each calibration screen of "REAR CAMERA", "FRONT CAMERA", "DR-SIDE CAMERA", and "PASS-SIDE CAMERA", operate "+" and "-" of "AXIS X", "AXIS Y", and "ROTATE", so that images on screen of target line and calibration maker are aligned.
  3. Press "APPLY" button on CONSULT screen. "Writing..." is displayed, and then the adjustment result is displayed on the display.

**CAUTION:**

**Check that "Writing..." is displayed. Never perform other operations while "Writing..." is displayed.**

4. Press "APPLY" button on CONSULT screen. "Writing..." is displayed, and then the adjustment result is written to around view monitor control unit.

**CAUTION:**

**Check that "Writing..." is displayed. Never perform other operations while "Writing..." is displayed.**

>> GO TO 6.

## 6. PERFORM "FINE TUNING OF BIRDS-EYE VIEW"

This mode is designed to align the boundary between each camera image that cannot be aligned in the "CALIBRATING CAMERA IMAGE" mode.

CONSULT work support

1. Select "FINE TUNING OF BIRDS-EYE VIEW".

# CALIBRATING CAMERA IMAGE (AROUND VIEW MONITOR)

< BASIC INSPECTION >

[AROUND VIEW MONITOR SYSTEM]

- Operate “+” and “-” of “AXIS X”, “AXIS Y”, and “ROTATE”, so that images on screen of target line on the ground and marker are aligned between each camera.

**CAUTION:**

**Perform adjustment operation slowly because approximately 1 second is required for changing image on screen.**

**NOTE:**

Press “SELECT” button on CONSULT screen and select camera position for adjustment.

- Press “APPLY” button on CONSULT screen. “Writing...” is displayed, and then the adjustment result is displayed on the display.

**CAUTION:**

**Check that “Writing...” is displayed. Never perform other operations while “Writing...” is displayed.**

- Press “APPLY” button on CONSULT screen. “Writing...” is displayed, and then the adjustment result is written to around view monitor control unit.

**CAUTION:**

• **Check that “Writing...” is displayed. Never perform other operations while “Writing...” is displayed.**

• **After selecting “OK”, never perform any operation other than “BACK” on CONSULT.**

**NOTE:**

- The setting can be initialized to the factory default setting using “CALIBRATING CAMERA IMAGE” of work support.
- The adjustment value on this mode is cancelled when “INITIALIZE CAMERA IMAGE CALIBRATION” is performed.

>> Calibration end

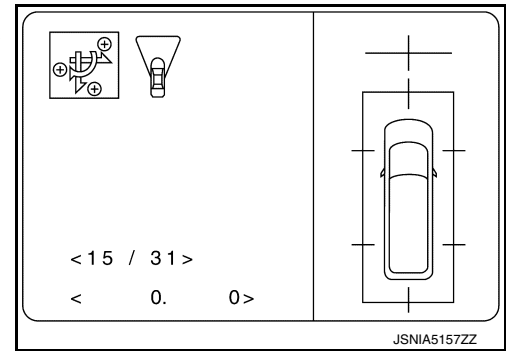

A  
B  
C  
D  
E  
F  
G  
H  
I  
J  
K  
L  
M  
O  
P

AV

# B2720 CORNER SENSOR [RL]

[AROUND VIEW MONITOR SYSTEM]

< DTC/CIRCUIT DIAGNOSIS >

## DTC/CIRCUIT DIAGNOSIS

### B2720 CORNER SENSOR [RL]

#### DTC Description

INFOID:0000000013717500

#### DTC DETECTION LOGIC

DTC	CONSULT screen items (Trouble diagnosis content)		DTC detecting condition	
B2720	CORNER SENSOR [RL] (Corner sensor rear-left)	SHORT-BAT (Short to battery)	Diagnosis condition	When ignition switch is ON
			Signal (terminal)	Corner sensor signal rear LH
			Threshold	Short circuit to power supply circuit
			Diagnosis delay time	4 seconds or more
		OPEN/SHORT-GND (Open/Short to ground)	Diagnosis condition	When ignition switch is ON
			Signal (terminal)	Corner sensor signal rear LH
			Threshold	Short circuit to ground or open circuit
			Diagnosis delay time	4 seconds or more
		SENSOR (Sensor)	Diagnosis condition	When ignition switch is ON
			Signal (terminal)	—
			Threshold	Malfunction in corner sensor rear LH
			Diagnosis delay time	2 seconds or more
		CONFIG ERROR (Configuration error)	Diagnosis condition	When ignition switch is ON
			Signal (terminal)	—
			Threshold	Control unit setting of sonar control unit is incomplete or is not set normally
			Diagnosis delay time	2 seconds or more

#### POSSIBLE CAUSE

- Harness or connectors (Corner sensor rear LH circuit)
- Corner sensor rear LH
- Control unit setting of sonar control unit is incomplete

#### FAIL-SAFE

Warning buzzer function is deactivated

#### DTC CONFIRMATION PROCEDURE

##### 1. PERFORM DTC CONFIRMATION PROCEDURE

##### ④ With CONSULT

1. Turn ignition switch ON.
2. Turn ignition switch OFF and wait at least 30 seconds.
3. Turn ignition switch ON and wait at least 5 seconds or more.
4. Select "Self Diagnostic Result" mode of "SONAR" using CONSULT.
5. Check DTC.

##### Is DTC B2720 detected?

YES (SHORT-BAT)>>Proceed to [AV-573. "SHORT-BAT : Diagnosis Procedure"](#).

YES (OPEN/SHORT-GND)>>Proceed to [AV-573. "OPEN/SHORT-GND : Diagnosis Procedure"](#).

YES (SENSOR)>>Proceed to [AV-574. "SENSOR : Diagnosis Procedure"](#).

YES (CONFIG ERROR)>>Proceed to [AV-574. "CONFIG ERROR : Diagnosis Procedure"](#).

NO-1 >> To check malfunction symptom before repair: Refer to [GI-44. "Intermittent Incident"](#).

NO-2 >> Confirmation after repair: INSPECTION END

#### SHORT-BAT

# B2720 CORNER SENSOR [RL]

[AROUND VIEW MONITOR SYSTEM]

< DTC/CIRCUIT DIAGNOSIS >

## SHORT-BAT : Diagnosis Procedure

INFOID:000000013717501

### 1.CHECK CORNER SENSOR REAR LH SIGNAL CIRCUIT FOR SHORT (1)

1. Turn ignition switch OFF.
2. Disconnect sonar control unit harness connector and corner sensor rear LH harness connector.
3. Turn ignition switch ON.
4. Check the voltage between sonar control unit harness connector and ground.

Terminals		(-)	Voltage (Approx.)
(+)			
Sonar control unit			
Connector	Terminal		
M76	22	Ground	0 V

Is the inspection result normal?

YES >> GO TO 2.

NO >> Repair or replace malfunctioning parts.

### 2.CHECK CORNER SENSOR REAR LH SIGNAL CIRCUIT FOR SHORT (2)

Check the continuity between corner sensor rear LH harness connector and ground.

Terminals		(-)	Continuity
(+)			
Corner sensor rear LH			
Connector	Terminal		
B90	2	Ground	Not existed

Is the inspection result normal?

YES >> Replace corner sensor rear LH. Refer to [AV-655, "REAR : Removal and Installation"](#).

NO >> Repair or replace malfunctioning parts.

## OPEN/SHORT-GND

### OPEN/SHORT-GND : Diagnosis Procedure

INFOID:000000013717502

### 1.CHECK CORNER SENSOR REAR LH SIGNAL CIRCUIT FOR OPEN

1. Turn ignition switch OFF.
2. Disconnect sonar control unit harness connector and corner sensor rear LH harness connector.
3. Check the continuity between sonar control unit harness connector and corner sensor rear LH harness connector.

Sonar control unit		Corner sensor rear LH		Continuity
Connector	Terminal	Connector	Terminal	
M76	22	B90	2	Existed

Is the inspection result normal?

YES >> GO TO 2.

NO >> Repair or replace malfunctioning parts.

### 2.CHECK CORNER SENSOR REAR LH SIGNAL CIRCUIT FOR SHORT

Check the continuity between sonar control unit harness connector and ground.

A  
B  
C  
D  
E  
F  
G  
H  
I  
J  
K  
L  
M  
O  
P

AV

## B2720 CORNER SENSOR [RL]

< DTC/CIRCUIT DIAGNOSIS >

[AROUND VIEW MONITOR SYSTEM]

Terminals			Continuity
(+)		(-)	
Connector	Terminal		
M76	22	Ground	Not existed

Is the inspection result normal?

YES >> GO TO 3.

NO >> Repair or replace malfunctioning parts.

### 3. CHECK CORNER SENSOR REAR LH GROUND CIRCUIT

Check the continuity between sonar control unit harness connector and corner sensor rear LH harness connector.

Sonar control unit		Corner sensor rear LH		Continuity
Connector	Terminal	Connector	Terminal	
M76	14	B90	1	Existed

Is the inspection result normal?

YES >> Replace corner sensor rear LH. Refer to [AV-655, "REAR : Removal and Installation"](#).

NO >> Repair or replace malfunctioning parts.

## SENSOR

### SENSOR : Diagnosis Procedure

INFOID:000000013717503

#### 1. PERFORM DTC CONFIRMATION PROCEDURE AGAIN

Ⓔ With CONSULT

1. Turn ignition switch ON.

2. Erase DTC.

3. Perform DTC confirmation procedure again. Refer to [AV-572, "DTC Description"](#).

Is DTC B2720 detected again?

YES >> Replace corner sensor rear LH. Refer to [AV-655, "REAR : Removal and Installation"](#).

NO >> INSPECTION END

## CONFIG ERROR

### CONFIG ERROR : Diagnosis Procedure

INFOID:000000013717504

#### 1. PERFORM CONFIGURATION OF SONAR CONTROL UNIT

Perform configuration of sonar control unit. Refer to [AV-564, "Work Procedure"](#).

>> GO TO 2.

#### 2. PERFORM DTC CONFIRMATION PROCEDURE AGAIN

Perform DTC confirmation procedure again. Refer to [AV-572, "DTC Description"](#).

Is DTC B2720 detected again?

YES >> Replace corner sensor rear LH. Refer to [AV-655, "REAR : Removal and Installation"](#).

NO >> INSPECTION END.

# B2721 CENTER SENSOR [RL]

< DTC/CIRCUIT DIAGNOSIS >

[AROUND VIEW MONITOR SYSTEM]

## B2721 CENTER SENSOR [RL]

### DTC Description

INFOID:000000013717505

### DTC DETECTION LOGIC

DTC	CONSULT screen items (Trouble diagnosis content)		DTC detecting condition	
B2721	CENTER SENSOR [RL] (Center sensor rear-left)	SHORT-BAT (Short to battery)	Diagnosis condition	When ignition switch is ON
			Signal (terminal)	Center sensor signal rear LH
			Threshold	Short circuit to power supply circuit
			Diagnosis delay time	4 seconds or more
		OPEN/SHORT-GND (Open/Short to ground)	Diagnosis condition	When ignition switch is ON
			Signal (terminal)	Center sensor signal rear LH
			Threshold	Short circuit to ground or open circuit
		SENSOR (Sensor)	Diagnosis condition	When ignition switch is ON
			Signal (terminal)	—
			Threshold	Malfunction in center sensor rear LH
			Diagnosis delay time	2 seconds or more
		CONFIG ERROR (Configuration error)	Diagnosis condition	When ignition switch is ON
			Signal (terminal)	—
			Threshold	Control unit setting of sonar control unit is incomplete or is not set normally
			Diagnosis delay time	2 seconds or more

### POSSIBLE CAUSE

- Harness or connectors (Center sensor rear LH circuit)
- Center sensor rear LH
- Control unit setting of sonar control unit is incomplete

### FAIL-SAFE

Warning buzzer function is deactivated

### DTC CONFIRMATION PROCEDURE

#### 1. PERFORM DTC CONFIRMATION PROCEDURE

Ⓜ With CONSULT

1. Turn ignition switch ON.
2. Turn ignition switch OFF and wait at least 30 seconds.
3. Turn ignition switch ON and wait at least 5 seconds or more.
4. Select "Self Diagnostic Result" mode of "SONAR" using CONSULT.
5. Check DTC.

Is DTC B2721 detected?

YES (SHORT-BAT)>>Proceed to [AV-576. "SHORT-BAT : Diagnosis Procedure"](#).

YES (OPEN/SHORT-GND)>>Proceed to [AV-576. "OPEN/SHORT-GND : Diagnosis Procedure"](#).

YES (SENSOR)>>Proceed to [AV-577. "SENSOR : Diagnosis Procedure"](#).

YES (CONFIG ERROR)>>Proceed to [AV-577. "CONFIG ERROR : Diagnosis Procedure"](#).

NO-1 >> To check malfunction symptom before repair: Refer to [GI-44. "Intermittent Incident"](#).

NO-2 >> Confirmation after repair: INSPECTION END

### SHORT-BAT

# B2721 CENTER SENSOR [RL]

[AROUND VIEW MONITOR SYSTEM]

< DTC/CIRCUIT DIAGNOSIS >

## SHORT-BAT : Diagnosis Procedure

INFOID:000000013717506

### 1. CHECK CENTER SENSOR REAR LH SIGNAL CIRCUIT FOR SHORT (1)

1. Turn ignition switch OFF.
2. Disconnect sonar control unit harness connector and center sensor rear LH harness connector.
3. Turn ignition switch ON.
4. Check the voltage between sonar control unit harness connector and ground.

Terminals		Voltage (Approx.)
(+) Sonar control unit		
Connector	Terminal	
M76	21	0 V

Is the inspection result normal?

YES >> GO TO 2.

NO >> Repair or replace malfunctioning parts.

### 2. CHECK CENTER SENSOR REAR LH SIGNAL CIRCUIT FOR SHORT (2)

Check the continuity between center sensor rear LH harness connector and ground.

Terminals		Continuity
(+) Center sensor rear LH		
Connector	Terminal	
B88	2	Not existed

Is the inspection result normal?

YES >> Replace center sensor rear LH. Refer to [AV-655, "REAR : Removal and Installation"](#).

NO >> Repair or replace malfunctioning parts.

## OPEN/SHORT-GND

### OPEN/SHORT-GND : Diagnosis Procedure

INFOID:000000013717507

### 1. CHECK CENTER SENSOR REAR LH SIGNAL CIRCUIT FOR OPEN

1. Turn ignition switch OFF.
2. Disconnect sonar control unit harness connector and center sensor rear LH harness connector.
3. Check the continuity between sonar control unit harness connector and center sensor rear LH harness connector.

Sonar control unit		Center sensor rear LH		Continuity
Connector	Terminal	Connector	Terminal	
M76	21	B88	2	Existed

Is the inspection result normal?

YES >> GO TO 2.

NO >> Repair or replace malfunctioning parts.

### 2. CHECK CENTER SENSOR REAR LH SIGNAL CIRCUIT FOR SHORT

Check the continuity between sonar control unit harness connector and ground.

# B2721 CENTER SENSOR [RL]

[AROUND VIEW MONITOR SYSTEM]

< DTC/CIRCUIT DIAGNOSIS >

Terminals			Continuity
(+)		(-)	
Sonar control unit			Ground
Connector	Terminal		
M76	21		

Is the inspection result normal?

YES >> GO TO 3.

NO >> Repair or replace malfunctioning parts.

## 3.CHECK CENTER SENSOR REAR LH GROUND CIRCUIT

Check the continuity between sonar control unit harness connector and center sensor rear LH harness connector.

Sonar control unit		Center sensor rear LH		Continuity
Connector	Terminal	Connector	Terminal	
M76	14	B88	1	Existed

Is the inspection result normal?

YES >> Replace center sensor rear LH. Refer to [AV-655, "REAR : Removal and Installation"](#).

NO >> Repair or replace malfunctioning parts.

## SENSOR

### SENSOR : Diagnosis Procedure

INFOID:000000013717508

#### 1.PERFORM DTC CONFIRMATION PROCEDURE AGAIN

④ With CONSULT

1. Turn ignition switch ON.

2. Erase DTC.

3. Perform DTC confirmation procedure again. Refer to [AV-575, "DTC Description"](#).

Is DTC B2721 detected again?

YES >> Replace center sensor rear LH. Refer to [AV-655, "REAR : Removal and Installation"](#).

NO >> INSPECTION END

## CONFIG ERROR

### CONFIG ERROR : Diagnosis Procedure

INFOID:000000013717509

#### 1.PERFORM CONFIGURATION OF SONAR CONTROL UNIT

Perform configuration of sonar control unit. Refer to [AV-564, "Work Procedure"](#).

>> GO TO 2.

#### 2.PERFORM DTC CONFIRMATION PROCEDURE AGAIN

Perform DTC confirmation procedure again. Refer to [AV-575, "DTC Description"](#).

Is DTC B2721 detected again?

YES >> Replace center sensor rear LH. Refer to [AV-655, "REAR : Removal and Installation"](#).

NO >> INSPECTION END.

A  
B  
C  
D  
E  
F  
G  
H  
I  
J  
K  
L  
M  
O  
P

AV

# B2722 CENTER SENSOR [RR]

< DTC/CIRCUIT DIAGNOSIS >

[AROUND VIEW MONITOR SYSTEM]

## B2722 CENTER SENSOR [RR]

### DTC Description

INFOID:000000013717510

### DTC DETECTION LOGIC

DTC	CONSULT screen items (Trouble diagnosis content)	DTC detecting condition		
B2722	CENTER SENSOR [RR] (Center sensor rear-right)	SHORT-BAT (Short to battery)	Diagnosis condition	When ignition switch is ON
			Signal (terminal)	Center sensor signal rear RH
			Threshold	Short circuit to power supply circuit
			Diagnosis delay time	4 seconds or more
		OPEN/SHORT-GND (Open/Short to ground)	Diagnosis condition	When ignition switch is ON
			Signal (terminal)	Center sensor signal rear RH
			Threshold	Short circuit to ground or open circuit
			Diagnosis delay time	4 seconds or more
		SENSOR (Sensor)	Diagnosis condition	When ignition switch is ON
			Signal (terminal)	—
			Threshold	Malfunction in center sensor rear RH
			Diagnosis delay time	2 seconds or more
	CONFIG ERROR (Configuration error)	Diagnosis condition	When ignition switch is ON	
		Signal (terminal)	—	
		Threshold	Control unit setting of sonar control unit is incomplete or is not set normally	
		Diagnosis delay time	2 seconds or more	

### POSSIBLE CAUSE

- Harness or connectors (Center sensor rear RH circuit)
- Center sensor rear RH
- Control unit setting of sonar control unit is incomplete

### FAIL-SAFE

Warning buzzer function is deactivated

### DTC CONFIRMATION PROCEDURE

#### 1. PERFORM DTC CONFIRMATION PROCEDURE

#### ④ With CONSULT

1. Turn ignition switch ON.
2. Turn ignition switch OFF and wait at least 30 seconds.
3. Turn ignition switch ON and wait at least 5 seconds or more.
4. Select "Self Diagnostic Result" mode of "SONAR" using CONSULT.
5. Check DTC.

#### Is DTC B2722 detected?

- YES (SHORT-BAT)>>Proceed to [AV-579. "SHORT-BAT : Diagnosis Procedure"](#).
- YES (OPEN/SHORT-GND)>>Proceed to [AV-579. "OPEN/SHORT-GND : Diagnosis Procedure"](#).
- YES (SENSOR)>>Proceed to [AV-580. "SENSOR : Diagnosis Procedure"](#).
- YES (CONFIG ERROR)>>Proceed to [AV-580. "CONFIG ERROR : Diagnosis Procedure"](#).
- NO-1 >> To check malfunction symptom before repair: Refer to [GI-44. "Intermittent Incident"](#).
- NO-2 >> Confirmation after repair: INSPECTION END

### SHORT-BAT

# B2722 CENTER SENSOR [RR]

[AROUND VIEW MONITOR SYSTEM]

< DTC/CIRCUIT DIAGNOSIS >

## SHORT-BAT : Diagnosis Procedure

INFOID:000000013717511

### 1.CHECK CENTER SENSOR REAR RH SIGNAL CIRCUIT FOR SHORT (1)

1. Turn ignition switch OFF.
2. Disconnect sonar control unit harness connector and center sensor rear RH connector.
3. Turn ignition switch ON.
4. Check the voltage between sonar control unit harness connector and ground.

Terminals		(-)	Voltage (Approx.)
(+)			
Sonar control unit			
Connector	Terminal		
M76	9	Ground	0 V

Is the inspection result normal?

YES >> GO TO 2.

NO >> Repair or replace malfunctioning parts.

### 2.CHECK CENTER SENSOR REAR RH SIGNAL CIRCUIT FOR SHORT (2)

Check the continuity between center sensor rear RH harness connector and ground.

Terminals		(-)	Continuity
(+)			
Center sensor rear RH			
Connector	Terminal		
B89	2	Ground	Not existed

Is the inspection result normal?

YES >> Replace center sensor rear RH. Refer to [AV-655. "REAR : Removal and Installation"](#).

NO >> Repair or replace malfunctioning parts.

## OPEN/SHORT-GND

### OPEN/SHORT-GND : Diagnosis Procedure

INFOID:000000013717512

### 1.CHECK CENTER SENSOR REAR RH SIGNAL CIRCUIT FOR OPEN

1. Turn ignition switch OFF.
2. Disconnect sonar control unit harness connector and center sensor rear RH harness connector.
3. Check the continuity between sonar control unit harness connector and center sensor rear RH harness connector.

Sonar control unit		Center sensor rear RH		Continuity
Connector	Terminal	Connector	Terminal	
M76	9	B89	2	Existed

Is the inspection result normal?

YES >> GO TO 2.

NO >> Repair or replace malfunctioning parts.

### 2.CHECK CENTER SENSOR REAR RH SIGNAL CIRCUIT FOR SHORT

Check the continuity between sonar control unit harness connector and ground.

A  
B  
C  
D  
E  
F  
G  
H  
I  
J  
K  
L  
M  
O  
P

AV

# B2722 CENTER SENSOR [RR]

[AROUND VIEW MONITOR SYSTEM]

< DTC/CIRCUIT DIAGNOSIS >

Terminals			Continuity
(+)		(-)	
Sonar control unit			Ground
Connector	Terminal		
M76	9	Ground	Not existed

Is the inspection result normal?

YES >> GO TO 3.

NO >> Repair or replace malfunctioning parts.

## 3. CHECK CENTER SENSOR REAR RH GROUND CIRCUIT

Check the continuity between sonar control unit harness connector and center sensor rear RH harness connector.

Sonar control unit		Center sensor rear RH		Continuity
Connector	Terminal	Connector	Terminal	
M76	14	B89	1	Existed

Is the inspection result normal?

YES >> Replace center sensor rear RH. Refer to [AV-655. "REAR : Removal and Installation"](#).

NO >> Repair or replace malfunctioning parts.

## SENSOR

### SENSOR : Diagnosis Procedure

INFOID:000000013717513

#### 1. PERFORM DTC CONFIRMATION PROCEDURE AGAIN

④ With CONSULT

1. Turn ignition switch ON.

2. Erase DTC.

3. Perform DTC confirmation procedure again. Refer to [AV-578. "DTC Description"](#).

Is DTC B2722 detected again?

YES >> Replace center sensor rear RH. Refer to [AV-655. "REAR : Removal and Installation"](#).

NO >> INSPECTION END

## CONFIG ERROR

### CONFIG ERROR : Diagnosis Procedure

INFOID:000000013717514

#### 1. PERFORM CONFIGURATION OF SONAR CONTROL UNIT

Perform configuration of sonar control unit. Refer to [AV-564. "Work Procedure"](#).

>> GO TO 2.

#### 2. PERFORM DTC CONFIRMATION PROCEDURE AGAIN

Perform DTC confirmation procedure again. Refer to [AV-578. "DTC Description"](#).

Is DTC B2722 detected again?

YES >> Replace center sensor rear RH. Refer to [AV-655. "REAR : Removal and Installation"](#).

NO >> INSPECTION END.

# B2723 CORNER SENSOR [RR]

< DTC/CIRCUIT DIAGNOSIS >

[AROUND VIEW MONITOR SYSTEM]

## B2723 CORNER SENSOR [RR]

### DTC Description

INFOID:000000013717515

### DTC DETECTION LOGIC

DTC	CONSULT screen items (Trouble diagnosis content)		DTC detecting condition	
B2723	CORNER SENSOR [RR] (Corner sensor rear-right)	SHORT-BAT (Short to battery)	Diagnosis condition	When ignition switch is ON
			Signal (terminal)	Corner sensor signal rear RH
			Threshold	Short circuit to power supply circuit
			Diagnosis delay time	4 seconds or more
		OPEN/SHORT-GND (Open/Short to ground)	Diagnosis condition	When ignition switch is ON
			Signal (terminal)	Corner sensor signal rear RH
			Threshold	Short circuit to ground or open circuit
		SENSOR (Sensor)	Diagnosis condition	When ignition switch is ON
			Signal (terminal)	—
			Threshold	Malfunction in corner sensor rear RH
			Diagnosis delay time	2 seconds or more
		CONFIG ERROR (Configuration error)	Diagnosis condition	When ignition switch is ON
			Signal (terminal)	—
			Threshold	Control unit setting of sonar control unit is incomplete or is not set normally
			Diagnosis delay time	2 seconds or more

### POSSIBLE CAUSE

- Harness or connectors (Corner sensor rear RH circuit)
- Corner sensor rear RH
- Control unit setting of sonar control unit is incomplete

### FAIL-SAFE

Warning buzzer function is deactivated

### DTC CONFIRMATION PROCEDURE

#### 1. PERFORM DTC CONFIRMATION PROCEDURE

Ⓜ With CONSULT

1. Turn ignition switch ON.
2. Turn ignition switch OFF and wait at least 30 seconds.
3. Turn ignition switch ON and wait at least 5 seconds or more.
4. Select "Self Diagnostic Result" mode of "SONAR" using CONSULT.
5. Check DTC.

Is DTC B2723 detected?

- YES (SHORT-BAT)>>Proceed to [AV-582. "SHORT-BAT : Diagnosis Procedure"](#).
- YES (OPEN/SHORT-GND)>>Proceed to [AV-582. "OPEN/SHORT-GND : Diagnosis Procedure"](#).
- YES (SENSOR)>>Proceed to [AV-583. "SENSOR : Diagnosis Procedure"](#).
- YES (CONFIG ERROR)>>Proceed to [AV-583. "CONFIG ERROR : Diagnosis Procedure"](#).
- NO-1 >> To check malfunction symptom before repair: Refer to [GI-44. "Intermittent Incident"](#).
- NO-2 >> Confirmation after repair: INSPECTION END

### SHORT-BAT

# B2723 CORNER SENSOR [RR]

[AROUND VIEW MONITOR SYSTEM]

< DTC/CIRCUIT DIAGNOSIS >

## SHORT-BAT : Diagnosis Procedure

INFOID:000000013717516

### 1.CHECK CORNER SENSOR REAR RH SIGNAL CIRCUIT FOR SHORT (1)

1. Turn ignition switch OFF.
2. Disconnect sonar control unit harness connector and corner sensor rear RH harness connector.
3. Turn ignition switch ON.
4. Check the voltage between sonar control unit harness connector and ground.

Terminals		(-)	Voltage (Approx.)
(+) Sonar control unit			
Connector	Terminal		
M76	10	Ground	0 V

Is the inspection result normal?

YES >> GO TO 2.

NO >> Repair or replace malfunctioning parts.

### 2.CHECK CORNER SENSOR REAR RH SIGNAL CIRCUIT FOR SHORT (2)

Check the continuity between corner sensor rear RH harness connector and ground.

Terminals		(-)	Continuity
(+) Corner sensor rear RH			
Connector	Terminal		
B91	2	Ground	Not existed

Is the inspection result normal?

YES >> Replace corner sensor rear RH. Refer to [AV-655. "REAR : Removal and Installation"](#).

NO >> Repair or replace malfunctioning parts.

## OPEN/SHORT-GND

### OPEN/SHORT-GND : Diagnosis Procedure

INFOID:000000013717517

### 1.CHECK CORNER SENSOR REAR RH SIGNAL CIRCUIT FOR OPEN

1. Turn ignition switch OFF.
2. Disconnect sonar control unit harness connector and corner sensor rear RH harness connector.
3. Check the continuity between sonar control unit harness connector and corner sensor rear RH harness connector.

Sonar control unit		Corner sensor rear RH		Continuity
Connector	Terminal	Connector	Terminal	
M76	10	B91	2	Existed

Is the inspection result normal?

YES >> GO TO 2.

NO >> Repair or replace malfunctioning parts.

### 2.CHECK CORNER SENSOR REAR RH SIGNAL CIRCUIT FOR SHORT

Check the continuity between sonar control unit harness connector and ground.

# B2723 CORNER SENSOR [RR]

[AROUND VIEW MONITOR SYSTEM]

< DTC/CIRCUIT DIAGNOSIS >

Terminals			Continuity
(+)		(-)	
Sonar control unit			Ground
Connector	Terminal		
M76	10		

Is the inspection result normal?

YES >> GO TO 3.

NO >> Repair or replace malfunctioning parts.

## 3. CHECK CORNER SENSOR REAR RH GROUND CIRCUIT

Check the continuity between sonar control unit harness connector and corner sensor rear RH harness connector.

Sonar control unit		Corner sensor rear RH		Continuity
Connector	Terminal	Connector	Terminal	
M76	14	B91	1	Existed

Is the inspection result normal?

YES >> Replace corner sensor rear RH. Refer to [AV-655, "REAR : Removal and Installation"](#).

NO >> Repair or replace malfunctioning parts.

## SENSOR

### SENSOR : Diagnosis Procedure

INFOID:000000013717518

#### 1. PERFORM DTC CONFIRMATION PROCEDURE AGAIN

④ With CONSULT

1. Turn ignition switch ON.

2. Erase DTC.

3. Perform DTC confirmation procedure again. Refer to [AV-581, "DTC Description"](#).

Is DTC B2723 detected again?

YES >> Replace corner sensor rear RH. Refer to [AV-655, "REAR : Removal and Installation"](#).

NO >> INSPECTION END

## CONFIG ERROR

### CONFIG ERROR : Diagnosis Procedure

INFOID:000000013717519

#### 1. PERFORM CONFIGURATION OF SONAR CONTROL UNIT

Perform configuration of sonar control unit. Refer to [AV-564, "Work Procedure"](#).

>> GO TO 2.

#### 2. PERFORM DTC CONFIRMATION PROCEDURE AGAIN

Perform DTC confirmation procedure again. Refer to [AV-581, "DTC Description"](#).

Is DTC B2723 detected again?

YES >> Replace corner sensor rear RH. Refer to [AV-655, "REAR : Removal and Installation"](#).

NO >> INSPECTION END.

A  
B  
C  
D  
E  
F  
G  
H  
I  
J  
K  
L  
M  
O  
P

AV

# B2724 SONAR CONTROL UNIT

< DTC/CIRCUIT DIAGNOSIS >

[AROUND VIEW MONITOR SYSTEM]

## B2724 SONAR CONTROL UNIT

### DTC Description

INFOID:000000013717520

### DTC DETECTION LOGIC

DTC	CONSULT screen items (Trouble diagnosis content)	DTC detecting condition	
		Diagnosis condition	When ignition switch is ON
B2724	SONAR CONTROL UNIT (Sonar control unit)	Signal (terminal)	—
		Threshold	Control unit setting of sonar control unit is incomplete or is not set normally
		Diagnosis delay time	2 seconds or more

### POSSIBLE CAUSE

Control unit setting of sonar control unit is incomplete

### FAIL-SAFE

Warning buzzer function is deactivated

### DTC CONFIRMATION PROCEDURE

#### 1.PERFORM DTC CONFIRMATION PROCEDURE

##### ④With CONSULT

1. Turn ignition switch ON.
2. Turn ignition switch OFF and wait at least 30 seconds.
3. Turn ignition switch ON and wait at least 2 seconds or more.
4. Select "Self Diagnostic Result" mode of "SONAR" using CONSULT.
5. Check DTC.

##### Is DTC B2724 detected?

- YES >> Proceed to [AV-584, "Diagnosis Procedure"](#).  
NO-1 >> To check malfunction symptom before repair: Refer to [GI-44, "Intermittent Incident"](#).  
NO-2 >> Confirmation after repair: INSPECTION END

### Diagnosis Procedure

INFOID:000000013717521

#### 1.PERFORM CONFIGURATION OF SONAR CONTROL UNIT

Perform configuration of sonar control unit. Refer to [AV-564, "Work Procedure"](#).

>> GO TO 2.

#### 2.PERFORM DTC CONFIRMATION PROCEDURE AGAIN

Perform DTC confirmation procedure again. Refer to [AV-584, "DTC Description"](#).

##### Is DTC B2724 detected again?

- YES >> Replace sonar control unit. Refer to [AV-652, "Removal and Installation"](#).  
NO >> INSPECTION END

# B2729 CORNER SENSOR [FL]

< DTC/CIRCUIT DIAGNOSIS >

[AROUND VIEW MONITOR SYSTEM]

## B2729 CORNER SENSOR [FL]

### DTC Description

INFOID:000000013717522

### DTC DETECTION LOGIC

DTC	CONSULT screen items (Trouble diagnosis content)		DTC detecting condition	
B2729	CORNER SENSOR [FL] (Corner sensor front-left)	SHORT-BAT (Short to battery)	Diagnosis condition	When ignition switch is ON
			Signal (terminal)	Corner sensor signal front LH
			Threshold	Short circuit to power supply circuit
			Diagnosis delay time	4 seconds or more
		OPEN/SHORT-GND (Open/Short to ground)	Diagnosis condition	When ignition switch is ON
			Signal (terminal)	Corner sensor signal front LH
			Threshold	Short circuit to ground or open circuit
		SENSOR (Sensor)	Diagnosis condition	When ignition switch is ON
			Signal (terminal)	—
			Threshold	Malfunction in corner sensor front LH
			Diagnosis delay time	2 seconds or more
		CONFIG ERROR (Configuration error)	Diagnosis condition	When ignition switch is ON
			Signal (terminal)	—
			Threshold	Control unit setting of sonar control unit is incomplete or is not set normally
			Diagnosis delay time	2 seconds or more

### POSSIBLE CAUSE

- Harness or connectors (Corner sensor front LH circuit)
- Corner sensor front LH
- Control unit setting of sonar control unit is incomplete

### FAIL-SAFE

Warning buzzer function is deactivated

### DTC CONFIRMATION PROCEDURE

#### 1. PERFORM DTC CONFIRMATION PROCEDURE

Ⓜ With CONSULT

1. Turn ignition switch ON.
2. Turn ignition switch OFF and wait at least 30 seconds.
3. Turn ignition switch ON and wait at least 5 seconds or more.
4. Select "Self Diagnostic Result" mode of "SONAR" using CONSULT.
5. Check DTC.

Is DTC B2729 detected?

- YES (SHORT-BAT)>>Proceed to [AV-586. "SHORT-BAT : Diagnosis Procedure"](#).
- YES (OPEN/SHORT-GND)>>Proceed to [AV-586. "OPEN/SHORT-GND : Diagnosis Procedure"](#).
- YES (SENSOR)>>Proceed to [AV-587. "SENSOR : Diagnosis Procedure"](#).
- YES (CONFIG ERROR)>>Proceed to [AV-587. "CONFIG ERROR : Diagnosis Procedure"](#).
- NO-1 >> To check malfunction symptom before repair: Refer to [GI-44. "Intermittent Incident"](#).
- NO-2 >> Confirmation after repair: INSPECTION END

### SHORT-BAT

# B2729 CORNER SENSOR [FL]

[AROUND VIEW MONITOR SYSTEM]

< DTC/CIRCUIT DIAGNOSIS >

## SHORT-BAT : Diagnosis Procedure

INFOID:000000013717523

### 1. CHECK CORNER SENSOR FRONT LH SIGNAL CIRCUIT FOR SHORT (1)

1. Turn ignition switch OFF.
2. Disconnect sonar control unit harness connector and corner sensor front LH harness connector.
3. Turn ignition switch ON.
4. Check the voltage between sonar control unit harness connector and ground.

Terminals			Voltage (Approx.)
(+)		(-)	
Sonar control unit			
Connector	Terminal		
M76	3	Ground	0 V

Is the inspection result normal?

YES >> GO TO 2.

NO >> Repair or replace malfunctioning parts.

### 2. CHECK CORNER SENSOR FRONT LH SIGNAL CIRCUIT FOR SHORT (2)

Check the continuity between corner sensor front LH harness connector ground.

Terminals			Continuity
(+)		(-)	
Corner sensor front LH			
Connector	Terminal		
E114	2	Ground	Not existed

Is the inspection result normal?

YES >> Replace corner sensor front LH. Refer to [AV-653, "FRONT : Removal and Installation"](#).

NO >> Repair or replace malfunctioning parts.

## OPEN/SHORT-GND

### OPEN/SHORT-GND : Diagnosis Procedure

INFOID:000000013717524

### 1. CHECK CORNER SENSOR FRONT LH SIGNAL CIRCUIT FOR OPEN

1. Turn ignition switch OFF.
2. Disconnect sonar control unit harness connector and corner sensor front LH harness connector.
3. Check the continuity between sonar control unit harness connector and corner sensor front LH harness connector.

Sonar control unit		Corner sensor front LH		Continuity
Connector	Terminal	Connector	Terminal	
M76	3	E114	2	Existed

Is the inspection result normal?

YES >> GO TO 2.

NO >> Repair or replace malfunctioning parts.

### 2. CHECK CORNER SENSOR FRONT LH SIGNAL CIRCUIT FOR SHORT

Check the continuity between sonar control unit harness connector and ground.

# B2729 CORNER SENSOR [FL]

[AROUND VIEW MONITOR SYSTEM]

< DTC/CIRCUIT DIAGNOSIS >

Terminals			Continuity
(+)		(-)	
Sonar control unit			Ground
Connector	Terminal		
M76	3		

Is the inspection result normal?

YES >> GO TO 3.

NO >> Repair or replace malfunctioning parts.

## 3. CHECK CORNER SENSOR FRONT LH GROUND CIRCUIT

Check the continuity between sonar control unit harness connector and corner sensor front LH harness connector.

Sonar control unit		Corner sensor front LH		Continuity
Connector	Terminal	Connector	Terminal	
M76	13	E114	1	Existed

Is the inspection result normal?

YES >> Replace corner sensor front LH. Refer to [AV-653, "FRONT : Removal and Installation"](#).

NO >> Repair or replace malfunctioning parts.

## SENSOR

### SENSOR : Diagnosis Procedure

INFOID:000000013717525

#### 1. PERFORM DTC CONFIRMATION PROCEDURE AGAIN

④ With CONSULT

1. Turn ignition switch ON.

2. Erase DTC.

3. Perform DTC confirmation procedure again. Refer to [AV-585, "DTC Description"](#).

Is DTC B2729 detected again?

YES >> Replace corner sensor front LH. Refer to [AV-653, "FRONT : Removal and Installation"](#).

NO >> INSPECTION END

## CONFIG ERROR

### CONFIG ERROR : Diagnosis Procedure

INFOID:000000013717526

#### 1. PERFORM CONFIGURATION OF SONAR CONTROL UNIT

Perform configuration of sonar control unit. Refer to [AV-564, "Work Procedure"](#).

>> GO TO 2.

#### 2. PERFORM DTC CONFIRMATION PROCEDURE AGAIN

Perform DTC confirmation procedure again. Refer to [AV-585, "DTC Description"](#).

Is DTC B2729 detected again?

YES >> Replace corner sensor front LH. Refer to [AV-653, "FRONT : Removal and Installation"](#).

NO >> INSPECTION END.

A  
B  
C  
D  
E  
F  
G  
H  
I  
J  
K  
L  
M  
O  
P

AV

# B272A CENTER SENSOR [FL]

< DTC/CIRCUIT DIAGNOSIS >

[AROUND VIEW MONITOR SYSTEM]

## B272A CENTER SENSOR [FL]

### DTC Description

INFOID:000000013717527

### DTC DETECTION LOGIC

DTC	CONSULT screen items (Trouble diagnosis content)	DTC detecting condition		
B272A	CENTER SENSOR [FL] (Center sensor front-left)	SHORT-BAT (Short to battery)	Diagnosis condition	When ignition switch is ON
			Signal (terminal)	Center sensor signal front LH
			Threshold	Short circuit to power supply circuit
			Diagnosis delay time	4 seconds or more
		OPEN/SHORT-GND (Open/Short to ground)	Diagnosis condition	When ignition switch is ON
			Signal (terminal)	Center sensor signal front LH
			Threshold	Short circuit to ground or open circuit
		SENSOR (Sensor)	Diagnosis condition	When ignition switch is ON
			Signal (terminal)	—
			Threshold	Malfunction in center sensor front LH
			Diagnosis delay time	2 seconds or more
		CONFIG ERROR (Configuration error)	Diagnosis condition	When ignition switch is ON
	Signal (terminal)		—	
	Threshold		Control unit setting of sonar control unit is incomplete or is not set normally	
	Diagnosis delay time		2 seconds or more	

### POSSIBLE CAUSE

- Harness or connectors (Center sensor front LH circuit)
- Center sensor front LH
- Control unit setting of sonar control unit is incomplete

### FAIL-SAFE

Warning buzzer function is deactivated

### DTC CONFIRMATION PROCEDURE

#### 1. PERFORM DTC CONFIRMATION PROCEDURE

##### Ⓟ With CONSULT

1. Turn ignition switch ON.
2. Turn ignition switch OFF and wait at least 30 seconds.
3. Turn ignition switch ON and wait at least 5 seconds or more.
4. Select "Self Diagnostic Result" mode of "SONAR" using CONSULT.
5. Check DTC.

##### Is DTC B272A detected?

- YES (SHORT-BAT)>>Proceed to [AV-589. "SHORT-BAT : Diagnosis Procedure"](#).
- YES (OPEN/SHORT-GND)>>Proceed to [AV-589. "OPEN/SHORT-GND : Diagnosis Procedure"](#).
- YES (SENSOR)>>Proceed to [AV-590. "SENSOR : Diagnosis Procedure"](#).
- YES (CONFIG ERROR)>>Proceed to [AV-590. "CONFIG ERROR : Diagnosis Procedure"](#).
- NO-1 >> To check malfunction symptom before repair: Refer to [GI-44. "Intermittent Incident"](#).
- NO-2 >> Confirmation after repair: INSPECTION END

### SHORT-BAT

# B272A CENTER SENSOR [FL]

[AROUND VIEW MONITOR SYSTEM]

< DTC/CIRCUIT DIAGNOSIS >

## SHORT-BAT : Diagnosis Procedure

INFOID:000000013717528

### 1.CHECK CENTER SENSOR FRONT LH SIGNAL CIRCUIT FOR SHORT (1)

1. Turn ignition switch OFF.
2. Disconnect sonar control unit harness connector and center sensor front LH harness connector.
3. Turn ignition switch ON.
4. Check the voltage between sonar control unit harness connector and ground.

Terminals			Voltage (Approx.)
(+)		(-)	
Connector	Terminal		
Sonar control unit		Ground	0 V
M76	2		

Is the inspection result normal?

YES >> GO TO 2.

NO >> Repair or replace malfunctioning parts.

### 2.CHECK CENTER SENSOR FRONT LH SIGNAL CIRCUIT FOR SHORT (2)

Check the continuity between center sensor front LH harness connector and ground.

Terminals			Continuity
(+)		(-)	
Connector	Terminal		
Center sensor front LH		Ground	Not existed
E112	2		

Is the inspection result normal?

YES >> Replace center sensor front LH. Refer to [AV-653, "FRONT : Removal and Installation"](#).

NO >> Repair or replace malfunctioning parts.

## OPEN/SHORT-GND

### OPEN/SHORT-GND : Diagnosis Procedure

INFOID:000000013717529

### 1.CHECK CENTER SENSOR FRONT LH SIGNAL CIRCUIT FOR OPEN

1. Turn ignition switch OFF.
2. Disconnect sonar control unit harness connector and center sensor front LH harness connector.
3. Check the continuity between sonar control unit harness connector and center sensor front LH harness connector.

Sonar control unit		Center sensor front LH		Continuity
Connector	Terminal	Connector	Terminal	
M76	2	E112	2	Existed

Is the inspection result normal?

YES >> GO TO 2.

NO >> Repair or replace malfunctioning parts.

### 2.CHECK CENTER SENSOR FRONT LH SIGNAL CIRCUIT FOR SHORT

Check the continuity between sonar control unit harness connector and ground.

A  
B  
C  
D  
E  
F  
G  
H  
I  
J  
K  
L  
M  
O  
P

AV

# B272A CENTER SENSOR [FL]

[AROUND VIEW MONITOR SYSTEM]

< DTC/CIRCUIT DIAGNOSIS >

Terminals			Continuity
(+)		(-)	
Sonar control unit			Ground
Connector	Terminal		
M76	2		

Is the inspection result normal?

YES >> GO TO 3.

NO >> Repair or replace malfunctioning parts.

## 3. CHECK CENTER SENSOR FRONT LH GROUND CIRCUIT

Check the continuity between sonar control unit harness connector and center sensor front LH harness connector.

Sonar control unit		Center sensor front LH		Continuity
Connector	Terminal	Connector	Terminal	
M76	13	E112	1	Existed

Is the inspection result normal?

YES >> Replace center sensor front LH. Refer to [AV-653, "FRONT : Removal and Installation"](#).

NO >> Repair or replace malfunctioning parts.

## SENSOR

### SENSOR : Diagnosis Procedure

INFOID:000000013717530

#### 1. PERFORM DTC CONFIRMATION PROCEDURE AGAIN

Ⓜ With CONSULT

1. Turn ignition switch ON.

2. Erase DTC.

3. Perform DTC confirmation procedure again. Refer to [AV-588, "DTC Description"](#).

Is DTC B272A detected again?

YES >> Replace center sensor front LH. Refer to [AV-653, "FRONT : Removal and Installation"](#).

NO >> INSPECTION END

## CONFIG ERROR

### CONFIG ERROR : Diagnosis Procedure

INFOID:000000013717531

#### 1. PERFORM CONFIGURATION OF SONAR CONTROL UNIT

Perform configuration of sonar control unit. Refer to [AV-564, "Work Procedure"](#).

>> GO TO 2.

#### 2. PERFORM DTC CONFIRMATION PROCEDURE AGAIN

Perform DTC confirmation procedure again. Refer to [AV-588, "DTC Description"](#).

Is DTC B272A detected again?

YES >> Replace center sensor front LH. Refer to [AV-653, "FRONT : Removal and Installation"](#).

NO >> INSPECTION END.

# B272B CENTER SENSOR [FR]

< DTC/CIRCUIT DIAGNOSIS >

[AROUND VIEW MONITOR SYSTEM]

## B272B CENTER SENSOR [FR]

### DTC Description

INFOID:000000013717532

### DTC DETECTION LOGIC

DTC	CONSULT screen items (Trouble diagnosis content)		DTC detecting condition	
B272B	CENTER SENSOR [FR] (Center sensor front-right)	SHORT-BAT (Short to battery)	Diagnosis condition	When ignition switch is ON
			Signal (terminal)	Center sensor signal front RH
			Threshold	Short circuit to power supply circuit
			Diagnosis delay time	4 seconds or more
		OPEN/SHORT-GND (Open/Short to ground)	Diagnosis condition	When ignition switch is ON
			Signal (terminal)	Center sensor signal front RH
			Threshold	Short circuit to ground or open circuit
		SENSOR (Sensor)	Diagnosis condition	When ignition switch is ON
			Signal (terminal)	—
			Threshold	Malfunction in center sensor front RH
			Diagnosis delay time	2 seconds or more
		CONFIG ERROR (Configuration error)	Diagnosis condition	When ignition switch is ON
			Signal (terminal)	—
			Threshold	Control unit setting of sonar control unit is incomplete or is not set normally
			Diagnosis delay time	2 seconds or more

### POSSIBLE CAUSE

- Harness or connectors (Center sensor front RH circuit)
- Center sensor front RH
- Control unit setting of sonar control unit is incomplete

### FAIL-SAFE

Warning buzzer function is deactivated

### DTC CONFIRMATION PROCEDURE

#### 1. PERFORM DTC CONFIRMATION PROCEDURE

Ⓜ With CONSULT

1. Turn ignition switch ON.
2. Turn ignition switch OFF and wait at least 30 seconds.
3. Turn ignition switch ON and wait at least 5 seconds or more.
4. Select "Self Diagnostic Result" mode of "SONAR" using CONSULT.
5. Check DTC.

Is DTC B272B detected?

- YES (SHORT-BAT)>>Proceed to [AV-592. "SHORT-BAT : Diagnosis Procedure"](#).
- YES (OPEN/SHORT-GND)>>Proceed to [AV-592. "OPEN/SHORT-GND : Diagnosis Procedure"](#).
- YES (SENSOR)>>Proceed to [AV-593. "SENSOR : Diagnosis Procedure"](#).
- YES (CONFIG ERROR)>>Proceed to [AV-593. "CONFIG ERROR : Diagnosis Procedure"](#).
- NO-1 >> To check malfunction symptom before repair: Refer to [GI-44. "Intermittent Incident"](#).
- NO-2 >> Confirmation after repair: INSPECTION END

### SHORT-BAT

# B272B CENTER SENSOR [FR]

[AROUND VIEW MONITOR SYSTEM]

< DTC/CIRCUIT DIAGNOSIS >

## SHORT-BAT : Diagnosis Procedure

INFOID:000000013717533

### 1. CHECK CENTER SENSOR FRONT RH SIGNAL CIRCUIT FOR SHORT (1)

1. Turn ignition switch OFF.
2. Disconnect sonar control unit harness connector and center sensor front RH harness connector.
3. Turn ignition switch ON.
4. Check the voltage between sonar control unit harness connector and ground.

Terminals		(-)	Voltage (Approx.)
(+)			
Sonar control unit		Ground	0 V
Connector	Terminal		
M76	1		

Is the inspection result normal?

YES >> GO TO 2.

NO >> Repair or replace malfunctioning parts.

### 2. CHECK CENTER SENSOR FRONT RH SIGNAL CIRCUIT FOR SHORT (2)

Check the continuity between center sensor front RH harness connector and ground.

Terminals		(-)	Continuity
(+)			
Center sensor front RH		Ground	Not existed
Connector	Terminal		
E113	2		

Is the inspection result normal?

YES >> Replace center sensor front RH. Refer to [AV-653, "FRONT : Removal and Installation"](#).

NO >> Repair or replace malfunctioning parts.

## OPEN/SHORT-GND

### OPEN/SHORT-GND : Diagnosis Procedure

INFOID:000000013717534

### 1. CHECK CENTER SENSOR FRONT RH SIGNAL CIRCUIT FOR OPEN

1. Turn ignition switch OFF.
2. Disconnect sonar control unit harness connector and center sensor front RH harness connector.
3. Check the continuity between sonar control unit harness connector and center sensor front RH harness connector.

Sonar control unit		Center sensor front RH		Continuity
Connector	Terminal	Connector	Terminal	
M76	1	E113	2	Existed

Is the inspection result normal?

YES >> GO TO 2.

NO >> Repair or replace malfunctioning parts.

### 2. CHECK CENTER SENSOR FRONT RH SIGNAL CIRCUIT FOR SHORT

Check the continuity between sonar control unit harness connector and ground.

# B272B CENTER SENSOR [FR]

[AROUND VIEW MONITOR SYSTEM]

< DTC/CIRCUIT DIAGNOSIS >

Terminals			Continuity
(+)		(-)	
Sonar control unit			
Connector	Terminal		
M76	1	Ground	Not existed

Is the inspection result normal?

YES >> GO TO 3.

NO >> Repair or replace malfunctioning parts.

## 3. CHECK CENTER SENSOR FRONT RH GROUND CIRCUIT

Check the continuity between sonar control unit harness connector and center sensor front RH harness connector.

Sonar control unit		Center sensor front RH		Continuity
Connector	Terminal	Connector	Terminal	
M76	13	E113	1	Existed

Is the inspection result normal?

YES >> Replace center sensor front RH. Refer to [AV-653, "FRONT : Removal and Installation"](#).

NO >> Repair or replace malfunctioning parts.

## SENSOR

### SENSOR : Diagnosis Procedure

INFOID:000000013717535

#### 1. PERFORM DTC CONFIRMATION PROCEDURE AGAIN

④ With CONSULT

1. Turn ignition switch ON.

2. Erase DTC.

3. Perform DTC confirmation procedure again. Refer to [AV-591, "DTC Description"](#).

Is DTC B272B detected again?

YES >> Replace center sensor front RH. Refer to [AV-653, "FRONT : Removal and Installation"](#).

NO >> INSPECTION END

## CONFIG ERROR

### CONFIG ERROR : Diagnosis Procedure

INFOID:000000013717536

#### 1. PERFORM CONFIGURATION OF SONAR CONTROL UNIT

Perform configuration of sonar control unit. Refer to [AV-564, "Work Procedure"](#).

>> GO TO 2.

#### 2. PERFORM DTC CONFIRMATION PROCEDURE AGAIN

Perform DTC confirmation procedure again. Refer to [AV-591, "DTC Description"](#).

Is DTC B272B detected again?

YES >> Replace center sensor front RH. Refer to [AV-653, "FRONT : Removal and Installation"](#).

NO >> INSPECTION END.

A  
B  
C  
D  
E  
F  
G  
H  
I  
J  
K  
L  
M  
O  
P

AV

# B272C CORNER SENSOR [FR]

< DTC/CIRCUIT DIAGNOSIS >

[AROUND VIEW MONITOR SYSTEM]

## B272C CORNER SENSOR [FR]

### DTC Description

INFOID:000000013717537

### DTC DETECTION LOGIC

DTC	CONSULT screen items (Trouble diagnosis content)	DTC detecting condition		
B272C	CORNER SENSOR [FR] (Corner sensor front-right)	SHORT-BAT (Short to battery)	Diagnosis condition	When ignition switch is ON
			Signal (terminal)	Corner sensor signal front RH
			Threshold	Short circuit to power supply circuit
			Diagnosis delay time	4 seconds or more
		OPEN/SHORT-GND (Open/Short to ground)	Diagnosis condition	When ignition switch is ON
			Signal (terminal)	Corner sensor signal front RH
			Threshold	Short circuit to ground or open circuit
			Diagnosis delay time	4 seconds or more
		SENSOR (Sensor)	Diagnosis condition	When ignition switch is ON
			Signal (terminal)	—
			Threshold	Malfunction in corner sensor front RH
			Diagnosis delay time	2 seconds or more
	CONFIG ERROR (Configuration error)	Diagnosis condition	When ignition switch is ON	
		Signal (terminal)	—	
		Threshold	Control unit setting of sonar control unit is incomplete or is not set normally	
		Diagnosis delay time	2 seconds or more	

### POSSIBLE CAUSE

- Harness or connectors (Corner sensor front RH circuit)
- Corner sensor front RH
- Control unit setting of sonar control unit is incomplete

### FAIL-SAFE

Warning buzzer function is deactivated

### DTC CONFIRMATION PROCEDURE

#### 1. PERFORM DTC CONFIRMATION PROCEDURE

##### ④ With CONSULT

1. Turn ignition switch ON.
2. Turn ignition switch OFF and wait at least 30 seconds.
3. Turn ignition switch ON and wait at least 5 seconds or more.
4. Select "Self Diagnostic Result" mode of "SONAR" using CONSULT.
5. Check DTC.

##### Is DTC B272C detected?

- YES (SHORT-BAT)>>Proceed to [AV-595. "SHORT-BAT : Diagnosis Procedure"](#).
- YES (OPEN/SHORT-GND)>>Proceed to [AV-595. "OPEN/SHORT-GND : Diagnosis Procedure"](#).
- YES (SENSOR)>>Proceed to [AV-596. "SENSOR : Diagnosis Procedure"](#).
- YES (CONFIG ERROR)>>Proceed to [AV-596. "CONFIG ERROR : Diagnosis Procedure"](#).
- NO-1 >> To check malfunction symptom before repair: Refer to [GI-44. "Intermittent Incident"](#).
- NO-2 >> Confirmation after repair: INSPECTION END

### SHORT-BAT

# B272C CORNER SENSOR [FR]

[AROUND VIEW MONITOR SYSTEM]

< DTC/CIRCUIT DIAGNOSIS >

## SHORT-BAT : Diagnosis Procedure

INFOID:000000013717538

### 1.CHECK CORNER SENSOR FRONT RH SIGNAL CIRCUIT FOR SHORT (1)

1. Turn ignition switch OFF.
2. Disconnect sonar control unit harness connector and corner sensor front RH harness connector.
3. Turn ignition switch ON.
4. Check the voltage between sonar control unit harness connector and ground.

Terminals		(-)	Voltage (Approx.)
(+)			
Sonar control unit			
Connector	Terminal		
M76	4	Ground	0 V

Is the inspection result normal?

YES >> GO TO 2.

NO >> Repair or replace malfunctioning parts.

### 2.CHECK CORNER SENSOR FRONT RH SIGNAL CIRCUIT FOR SHORT (2)

Check the continuity between corner sensor front RH harness connector and ground.

Terminals		(-)	Continuity
(+)			
Corner sensor front RH			
Connector	Terminal		
E115	2	Ground	Not existed

Is the inspection result normal?

YES >> Replace corner sensor front RH. Refer to [AV-653, "FRONT : Removal and Installation"](#).

NO >> Repair or replace malfunctioning parts.

## OPEN/SHORT-GND

### OPEN/SHORT-GND : Diagnosis Procedure

INFOID:000000013717539

### 1.CHECK CORNER SENSOR FRONT RH SIGNAL CIRCUIT FOR OPEN

1. Turn ignition switch OFF.
2. Disconnect sonar control unit harness connector and corner sensor front RH harness connector.
3. Check the continuity between sonar control unit harness connector and corner sensor front RH harness connector.

Sonar control unit		Corner sensor front RH		Continuity
Connector	Terminal	Connector	Terminal	
M76	4	E115	2	Existed

Is the inspection result normal?

YES >> GO TO 2.

NO >> Repair or replace malfunctioning parts.

### 2.CHECK CORNER SENSOR FRONT RH SIGNAL CIRCUIT FOR SHORT

Check the continuity between sonar control unit harness connector and ground.

A  
B  
C  
D  
E  
F  
G  
H  
I  
J  
K  
L  
M  
O  
P

AV

# B272C CORNER SENSOR [FR]

< DTC/CIRCUIT DIAGNOSIS >

[AROUND VIEW MONITOR SYSTEM]

Terminals			Continuity
(+)		(-)	
Sonar control unit			
Connector	Terminal		
M76	4	Ground	Not existed

Is the inspection result normal?

YES >> GO TO 3.

NO >> Repair or replace malfunctioning parts.

## 3. CHECK CORNER SENSOR FRONT RH GROUND CIRCUIT

Check the continuity between sonar control unit harness connector and corner sensor front RH harness connector.

Sonar control unit		Corner sensor front RH		Continuity
Connector	Terminal	Connector	Terminal	
M76	13	E115	1	Existed

Is the inspection result normal?

YES >> Replace corner sensor front RH. Refer to [AV-653. "FRONT : Removal and Installation"](#).

NO >> Repair or replace malfunctioning parts.

## SENSOR

### SENSOR : Diagnosis Procedure

INFOID:000000013717540

#### 1. PERFORM DTC CONFIRMATION PROCEDURE AGAIN

Ⓜ With CONSULT

1. Turn ignition switch ON.

2. Erase DTC.

3. Perform DTC confirmation procedure again. Refer to [AV-594. "DTC Description"](#).

Is DTC B272C detected again?

YES >> Replace corner sensor front RH. Refer to [AV-653. "FRONT : Removal and Installation"](#).

NO >> INSPECTION END

## CONFIG ERROR

### CONFIG ERROR : Diagnosis Procedure

INFOID:000000013717541

#### 1. PERFORM CONFIGURATION OF SONAR CONTROL UNIT

Perform configuration of sonar control unit. Refer to [AV-564. "Work Procedure"](#).

>> GO TO 2.

#### 2. PERFORM DTC CONFIRMATION PROCEDURE AGAIN

Perform DTC confirmation procedure again. Refer to [AV-594. "DTC Description"](#).

Is DTC B272C detected again?

YES >> Replace corner sensor front RH. Refer to [AV-653. "FRONT : Removal and Installation"](#).

NO >> INSPECTION END.

# B272D FRONT BUZZER

< DTC/CIRCUIT DIAGNOSIS >

[AROUND VIEW MONITOR SYSTEM]

## B272D FRONT BUZZER

### DTC Description

INFOID:000000013717542

### DTC DETECTION LOGIC

DTC	CONSULT screen items (Trouble diagnosis content)		DTC detecting condition	
			Diagnosis condition	Signal (terminal)
B272D	FRONT BUZZER (Front buzzer)	SHORT-BAT (Short to battery)	When ignition switch is ON	Buzzer drive signal
			Short circuit to power supply circuit	4 seconds or more
			When ignition switch is ON	Buzzer drive signal
			Short circuit to ground or open circuit	2 seconds or more
		OPEN/SHORT-GND (Open circuit/short to ground)	When ignition switch is ON	Buzzer drive signal
			Short circuit to ground or open circuit	2 seconds or more

### POSSIBLE CAUSE

Harness between sonar control unit and buzzer

### FAIL-SAFE

Obstacle detection function is stopped

### DTC CONFIRMATION PROCEDURE

#### 1. PERFORM DTC CONFIRMATION PROCEDURE

Ⓜ With CONSULT

- Turn ignition switch ON.
- Turn ignition switch OFF and wait at least 30 seconds.
- Turn ignition switch ON and wait at least 5 seconds or more.
- Select "Self Diagnostic Result" mode of "SONAR" using CONSULT.
- Check DTC.

Is DTC B272D detected?

YES (SHORT-BAT) >> Proceed to [AV-597, "SHORT-BAT : Diagnosis Procedure"](#).

YES (OPEN/SHORT-GND) >> Proceed to [AV-598, "OPEN/SHORT-GND : Diagnosis Procedure"](#).

NO-1 >> To check malfunction symptom before repair: Refer to [GI-44, "Intermittent Incident"](#).

NO-2 >> Confirmation after repair: INSPECTION END

### SHORT-BAT

#### SHORT-BAT : Diagnosis Procedure

INFOID:000000014082241

#### 1. CHECK BUZZER POWER SUPPLY CIRCUIT

- Turn ignition switch OFF.
- Disconnect sonar control unit connector and buzzer connector.
- Turn ignition switch ON.
- Check voltage between sonar control unit harness connector and ground.

Sonar control unit		Ground	Standard	Reference value (Approx.)
Connector	Terminal			
M76	19		—	0 V

Is the inspection result normal?

YES >> GO TO 2.

NO >> Repair harness or connector.

#### 2. CHECK BUZZER DRIVE SIGNAL CIRCUIT

# B272D FRONT BUZZER

[AROUND VIEW MONITOR SYSTEM]

## < DTC/CIRCUIT DIAGNOSIS >

1. Turn ignition switch OFF.
2. Connect sonar control unit connector and buzzer connector.
3. Turn ignition switch ON.
4. Check voltage between sonar control unit harness connector and ground.

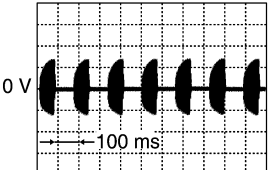
Sonar control unit		Condition	Standard	Reference value (Approx.)
Connector	Terminal			
M76	18	Ground	—	<b>NOTE:</b> <ul style="list-style-type: none"> <li>• Voltage depends on volume.</li> <li>• Cycle depends on distance between sensor and obstacle.</li> </ul>  <p style="text-align: right; font-size: small;">JSNIA5232GB</p>

Is the inspection result normal?

- YES >> Replace buzzer. Refer to [AV-658, "Removal and Installation"](#).  
 NO >> Repair harness or connector.

## OPEN/SHORT-GND

### OPEN/SHORT-GND : Diagnosis Procedure

INFOID:000000014082242

#### 1. CHECK CONTINUITY BUZZER POWER SUPPLY CIRCUIT

1. Turn ignition switch OFF.
2. Disconnect sonar control unit connector and buzzer connector.
3. Check continuity between sonar control unit harness connector and buzzer harness connector.

Sonar control unit		Buzzer		Continuity
Connector	Terminal	Connector	Terminal	
M76	19	M110	2	Existed

4. Check continuity between sonar control unit harness connector and ground.

Sonar control unit		Ground	Continuity
Connector	Terminal		
M76	19		Not existed

Is the inspection result normal?

- YES >> GO TO 2.  
 NO >> Repair harness or connector.

#### 2. CHECK CONTINUITY BUZZER DRIVE SIGNAL CIRCUIT

1. Check continuity between sonar control unit harness connector and buzzer harness connector.

Sonar control unit		Buzzer		Continuity
Connector	Terminal	Connector	Terminal	
M76	18	M110	3	Existed

2. Check continuity between sonar control unit harness connector and ground.

# B272D FRONT BUZZER

< DTC/CIRCUIT DIAGNOSIS >

[AROUND VIEW MONITOR SYSTEM]

Sonar control unit		Ground	Continuity
Connector	Terminal		
M76	18		Not existed

Is the inspection result normal?

YES >> GO TO 3.

NO >> Repair harness or connector.

## 3. CHECK CONTINUITY SONAR CONTROL UNIT

1. Check continuity between terminals of sonar control unit.

Sonar control unit		Continuity.
Terminal		
19	18	Not existed

2. Check continuity between sonar control unit terminal and ground.

Sonar control unit	Ground	Continuity
Terminal		
19		Not existed
18		

Is the inspection result normal?

YES >> Replace buzzer. Refer to [AV-658, "Removal and Installation"](#).

NO >> Replace sonar control unit. Refer to [AV-652, "Removal and Installation"](#).

A  
B  
C  
D  
E  
F  
G  
H  
I  
J  
K  
L  
M  
O  
P

AV

# U0428 STEERING ANGLE SENSOR

< DTC/CIRCUIT DIAGNOSIS >

[AROUND VIEW MONITOR SYSTEM]

## U0428 STEERING ANGLE SENSOR

### DTC Description

INFOID:000000013717544

### DTC DETECTION LOGIC

DTC	CONSULT screen terms (Trouble diagnosis content)	DTC detection condition	
U0428	ST ANGLE SENSOR CALIBRATION (Steering angle sensor calibration)	Diagnosis condition	When ignition switch is ON
		Signal (terminal)	CAN communication signal
		Threshold	The neutral position adjustment of the steering angle sensor is incomplete.
		Diagnosis delay time	2 seconds or more

### POSSIBLE CAUSE

Neutral position adjustment of steering angle sensor is not complete

### FAIL-SAFE

- Predicted course line is not displayed
- MOD (Moving Object Detection) function is stopped
- Front tire angle display is stopped
- Using "SETTING" menu display, switch each indicator of predicted course line display and MOD switch to "OFF" (turn OFF) so that switch operation cannot be performed

### DTC CONFIRMATION PROCEDURE

#### 1. CHECK DTC PRIORITY

If DTC U0428 is displayed with DTC U1232, first perform the confirmation procedure (trouble diagnosis) for DTC U1232.

#### Is applicable DTC detected?

- YES >> Perform diagnosis of applicable. Refer to [AV-619, "DTC Description"](#).  
NO >> GO TO 2.

#### 2. PERFORM DTC CONFIRMATION PROCEDURE

##### Ⓜ With CONSULT

1. Turn ignition switch ON.
2. Turn ignition switch OFF and wait at least 30 seconds.
3. Turn ignition switch ON and wait at least 2 seconds or more.
4. Select "Self Diagnostic Result" mode of "AVM" using CONSULT.
5. Check DTC.

#### Is DTC U0428 detected?

- YES >> Proceed to [AV-600, "Diagnosis Procedure"](#).  
NO-1 >> To check malfunction symptom before repair: [GI-44, "Intermittent Incident"](#).  
NO-2 >> Confirmation after repair: INSPECTION END

### Diagnosis Procedure

INFOID:000000013717545

#### 1. ADJUST THE NEUTRAL POSITION OF THE STEERING ANGLE SENSOR

When U0428 is detected, adjust the neutral position of the steering angle sensor.

Perform adjustment of the neutral position of the steering angle sensor. Refer to [BRC-92, "Work Procedure"](#).

#### **CAUTION:**

**For vehicles with VDC, adjust the steering angle sensor neutral position on the ABS actuator control unit side.**

>> GO TO 2.

#### 2. PERFORM DTC CONFIRMATION PROCEDURE AGAIN

Perform DTC confirmation procedure again. Refer to [AV-600, "DTC Description"](#).

## U0428 STEERING ANGLE SENSOR

< DTC/CIRCUIT DIAGNOSIS >

[AROUND VIEW MONITOR SYSTEM]

Is DTC U0428 detected again?

YES >> Replace steering angle sensor. Refer to [AV-659, "Removal and Installation"](#).  
NO >> INSPECTION END

A

B

C

D

E

F

G

H

I

J

K

L

M

AV

O

P

# U1000 CAN COMM CIRCUIT

< DTC/CIRCUIT DIAGNOSIS >

[AROUND VIEW MONITOR SYSTEM]

## U1000 CAN COMM CIRCUIT

### AROUND VIEW MONITOR CONTROL UNIT

#### AROUND VIEW MONITOR CONTROL UNIT : DTC Description

INFOID:000000013717546

#### DESCRIPTION

CAN (Controller Area Network) is a serial communication line for real-time application. It is an on-vehicle multiplex communication line with high data communication speed and excellent error detection ability. Many electronic control units are equipped onto a vehicle, and each control unit shares information and links with other control units during operation (not independently). In CAN communication, control units are connected with 2 communication lines (CAN-H, CAN-L) allowing a high rate of information transmission with less wiring. Each control unit transmits/receives data but selectively reads required data only.

CAN Communication Signal Chart. Refer to [LAN-68. "CAN COMMUNICATION SYSTEM : CAN Communication Signal Chart \(VR30DDTT Engine Models\)"](#) (VR30DDTT engine models) or [LAN-61. "CAN COMMUNICATION SYSTEM : CAN Communication Signal Chart \(2.0L Turbo Gasoline Engine Models\)"](#) (2.0L turbo gasoline engine models).

#### DTC DETECTION LOGIC

DTC	CONSULT screen terms (Trouble diagnosis content)	DTC detection condition	
U1000	CAN COMM CIRCUIT (CAN communication circuit)	Diagnosis condition	When ignition switch is ON
		Signal (terminal)	CAN communication signal
		Threshold	Communication error
		Diagnosis delay time	2 seconds or more

#### POSSIBLE CAUSE

CAN communication system

#### FAIL-SAFE

The following functions are stopped

- When communication of steering angle sensor signal is not normal
  - Predicted course line is not displayed
  - MOD (Moving Object Detection) function is stopped
  - Front tire angle display is stopped
  - Using "SETTING" menu display, switch each indicator of predicted course line display and MOD switch to "OFF" (turn OFF) so that switch operation cannot be performed
- When communication of vehicle signal, wheel speed sensor signal, and shift signal is not normal
  - Predicted course line is not displayed
  - MOD (Moving Object Detection) function is stopped.
  - Using "SETTING" menu display, switch each indicator of predicted course line display and MOD switch to "OFF" (turn OFF) so that switch operation cannot be performed
- When communication of sonar signal is not normal
  - Predicted course line is not displayed

#### DTC CONFIRMATION PROCEDURE

##### 1. PERFORM DTC CONFIRMATION PROCEDURE

##### Ⓟ With CONSULT

1. Turn ignition switch ON.
2. Turn ignition switch OFF and wait at least 30 seconds.
3. Turn ignition switch ON and wait at least 2 seconds or more.
4. Select "Self Diagnostic Result" mode of "AVM" using CONSULT.
5. Check DTC.

##### Is DTC U1000 detected?

- YES >> Proceed to [AV-603. "AROUND VIEW MONITOR CONTROL UNIT : Diagnosis Procedure"](#).  
NO-1 >> To check malfunction symptom before repair: [GI-44. "Intermittent Incident"](#).  
NO-2 >> Confirmation after repair: INSPECTION END

# U1000 CAN COMM CIRCUIT

< DTC/CIRCUIT DIAGNOSIS >

[AROUND VIEW MONITOR SYSTEM]

## AROUND VIEW MONITOR CONTROL UNIT : Diagnosis Procedure

INFOID:000000013717547

### 1. PERFORM DTC CONFIRMATION PROCEDURE AGAIN

④ With CONSULT

1. Turn ignition switch ON.
2. Erase DTC.
3. Perform DTC confirmation procedure again. Refer to [AV-602, "AROUND VIEW MONITOR CONTROL UNIT : DTC Description"](#).

Is DTC U1000 detected again?

YES >> Perform the trouble diagnosis for CAN communication system. Refer to [LAN-37, "Trouble Diagnosis Flow Chart"](#).

NO >> INSPECTION END

## SONAR CONTROL UNIT

### SONAR CONTROL UNIT : DTC Description

INFOID:000000013717548

#### DESCRIPTION

CAN (Controller Area Network) is a serial communication line for real-time application. It is an on-vehicle multiplex communication line with high data communication speed and excellent error detection ability. Many electronic control units are equipped onto a vehicle, and each control unit shares information and links with other control units during operation (not independently). In CAN communication, control units are connected with 2 communication lines (CAN-H, CAN-L) allowing a high rate of information transmission with less wiring. Each control unit transmits/receives data but selectively reads required data only.

CAN Communication Signal Chart. Refer to [LAN-68, "CAN COMMUNICATION SYSTEM : CAN Communication Signal Chart \(VR30DDTT Engine Models\)"](#) (VR30DDTT engine models) or [LAN-61, "CAN COMMUNICATION SYSTEM : CAN Communication Signal Chart \(2.0L Turbo Gasoline Engine Models\)"](#) (2.0L turbo gasoline engine models).

#### DTC DETECTION LOGIC

DTC	CONSULT screen items (Trouble diagnosis content)	DTC detecting condition	
U1000	CAN COMM CIRCUIT (CAN communication circuit)	Diagnosis condition	When ignition switch is ON
		Signal (terminal)	CAN communication signal
		Threshold	Communication error
		Diagnosis delay time	2 seconds or more

#### POSSIBLE CAUSE

CAN communication system

#### FAIL-SAFE

Warning buzzer function is deactivated

#### DTC CONFIRMATION PROCEDURE

### 1. PERFORM DTC CONFIRMATION PROCEDURE

④ With CONSULT

1. Turn ignition switch ON.
2. Turn ignition switch OFF and wait at least 30 seconds.
3. Turn ignition switch ON and wait at least 2 seconds or more.
4. Select "Self Diagnostic Result" mode of "SONAR" using CONSULT.
5. Check DTC.

Is DTC U1000 detected?

YES >> Proceed to [AV-604, "SONAR CONTROL UNIT : Diagnosis Procedure"](#).

NO-1 >> To check malfunction symptom before repair: Refer to [GI-44, "Intermittent Incident"](#).

NO-2 >> Confirmation after repair: INSPECTION END

## U1000 CAN COMM CIRCUIT

< DTC/CIRCUIT DIAGNOSIS >

[AROUND VIEW MONITOR SYSTEM]

### SONAR CONTROL UNIT : Diagnosis Procedure

INFOID:000000013717549

#### 1. PERFORM DTC CONFIRMATION PROCEDURE AGAIN

Ⓟ With CONSULT

1. Turn ignition switch ON.
2. Erase DTC.
3. Perform DTC confirmation procedure again. Refer to [AV-603. "SONAR CONTROL UNIT : DTC Description"](#).

Is DTC U1000 detected again?

- YES >> Perform the trouble diagnosis for CAN communication system. Refer to [LAN-37. "Trouble Diagnosis Flow Chart"](#).
- NO >> INSPECTION END

# U1010 CONTROL UNIT (CAN)

< DTC/CIRCUIT DIAGNOSIS >

[AROUND VIEW MONITOR SYSTEM]

## U1010 CONTROL UNIT (CAN)

### AROUND VIEW MONITOR CONTROL UNIT

#### AROUND VIEW MONITOR CONTROL UNIT : DTC Description

INFOID:0000000013717550

#### DTC DETECTION LOGIC

DTC	CONSULT screen terms (Trouble diagnosis content)	DTC detection condition	
		Diagnosis condition	When ignition switch is ON
U1010	CONTROL UNIT (CAN) [Control unit (CAN)]	Signal (terminal)	—
		Threshold	Initial diagnosis abnormality
		Diagnosis delay time	2 seconds or more

#### POSSIBLE CAUSE

Around view monitor control unit

#### FAIL-SAFE

Around view monitor system does not function

#### DTC CONFIRMATION PROCEDURE

##### 1. PERFORM DTC CONFIRMATION PROCEDURE

###### Ⓜ With CONSULT

- Turn ignition switch ON.
- Turn ignition switch OFF and wait at least 30 seconds.
- Turn ignition switch ON and wait at least 2 seconds or more.
- Select "Self Diagnostic Result" mode of "AVM" using CONSULT.
- Check DTC.

###### Is DTC U1010 detected?

YES >> Proceed to [AV-605, "AROUND VIEW MONITOR CONTROL UNIT : Diagnosis Procedure"](#).

NO-1 >> To check malfunction symptom before repair: [GI-44, "Intermittent Incident"](#).

NO-2 >> Confirmation after repair: INSPECTION END

#### AROUND VIEW MONITOR CONTROL UNIT : Diagnosis Procedure

INFOID:0000000013717551

##### 1. PERFORM DTC CONFIRMATION PROCEDURE AGAIN

###### Ⓜ With CONSULT

- Turn ignition switch ON.
- Erase DTC.
- Perform DTC confirmation procedure again. Refer to [AV-605, "AROUND VIEW MONITOR CONTROL UNIT : DTC Description"](#).

###### Is DTC U1010 detected again?

YES >> Replace around view monitor control unit. Refer to [AV-647, "Removal and Installation"](#).

NO >> INSPECTION END

## SONAR CONTROL UNIT

#### SONAR CONTROL UNIT : DTC Description

INFOID:0000000013717552

#### DTC DETECTION LOGIC

# U1010 CONTROL UNIT (CAN)

< DTC/CIRCUIT DIAGNOSIS >

[AROUND VIEW MONITOR SYSTEM]

DTC	CONSULT screen items (Trouble diagnosis content)	DTC detecting condition	
U1010	CONTROL UNIT (CAN) [Control unit (CAN)]	Diagnosis condition	When ignition switch is ON
		Signal (terminal)	—
		Threshold	Malfunction is detected during initial diagnosis of the sonar control unit CAN controller.
		Diagnosis delay time	2 seconds or more

## POSSIBLE CAUSE

Sonar control unit

## FAIL-SAFE

Warning buzzer function is deactivated

## DTC CONFIRMATION PROCEDURE

### 1. PERFORM DTC CONFIRMATION PROCEDURE

#### Ⓜ With CONSULT

1. Turn ignition switch ON.
2. Turn ignition switch OFF and wait at least 30 seconds.
3. Turn ignition switch ON and wait at least 2 seconds or more.
4. Select "Self Diagnostic Result" mode of "SONAR using CONSULT."
5. Check DTC.

#### Is DTC U1010 detected?

- YES >> Proceed to [AV-606. "SONAR CONTROL UNIT : Diagnosis Procedure"](#).  
NO-1 >> To check malfunction symptom before repair: Refer to [GI-44. "Intermittent Incident"](#).  
NO-2 >> Confirmation after repair: INSPECTION END

## SONAR CONTROL UNIT : Diagnosis Procedure

INFOID:000000013717553

### 1. PERFORM DTC CONFIRMATION PROCEDURE AGAIN

#### Ⓜ With CONSULT

1. Turn ignition switch ON.
2. Erase DTC.
3. Perform DTC confirmation procedure again. Refer to [AV-605. "SONAR CONTROL UNIT : DTC Description"](#).

#### Is DTC U1010 detected again?

- YES >> Replace sonar control unit. Refer to [AV-652. "Removal and Installation"](#).  
NO >> INSPECTION END

# U111A REAR CAMERA IMAGE SIGNAL CIRCUIT

< DTC/CIRCUIT DIAGNOSIS >

[AROUND VIEW MONITOR SYSTEM]

## U111A REAR CAMERA IMAGE SIGNAL CIRCUIT

### DTC Description

INFOID:000000013717554

### DTC DETECTION LOGIC

DTC	CONSULT screen terms (Trouble diagnosis content)	DTC detection condition	
		Diagnosis condition	When ignition switch is ON
U111A	REAR CAMERA IMAGE SIGNAL (Rear camera image signal)	Signal (terminal)	Rear camera image signal
		Threshold	Open or shorted
		Diagnosis delay time	30 seconds or more

### POSSIBLE CAUSE

Rear camera image signal circuit

### FAIL-SAFE

Camera image is not displayed (Gray screen display)

### DTC CONFIRMATION PROCEDURE

#### 1. PERFORM DTC CONFIRMATION PROCEDURE

##### Ⓜ With CONSULT

- Turn ignition switch ON.
- Turn ignition switch OFF and wait at least 30 seconds.
- Turn ignition switch ON and wait at least 30 seconds or more.
- Select "Self Diagnostic Result" mode of "AVM" using CONSULT.
- Check DTC.

##### Is DTC U111A detected?

YES >> Proceed to [AV-607, "Diagnosis Procedure"](#).

NO-1 >> To check malfunction symptom before repair: [GI-44, "Intermittent Incident"](#).

NO-2 >> Confirmation after repair: INSPECTION END

### Diagnosis Procedure

INFOID:000000013717555

#### 1. CHECK CONTINUITY REAR CAMERA POWER SUPPLY AND GROUND CIRCUIT

- Turn ignition switch OFF.
- Disconnect around view monitor control unit connector and rear camera connector.
- Check continuity between around view monitor control unit harness connector and rear camera harness connector.

Around view monitor control unit		Rear camera		Continuity
Connector	Terminal	Connector	Terminal	
B51	50	T50	8	Existed
	52		7	

- Check continuity between around view monitor control unit harness connector and ground.

Around view monitor control unit		Ground	Continuity
Connector	Terminal		
B51	50		Not existed

##### Is the inspection result normal?

YES >> GO TO 2.

NO >> Repair harness or connector.

# U111A REAR CAMERA IMAGE SIGNAL CIRCUIT

< DTC/CIRCUIT DIAGNOSIS >

[AROUND VIEW MONITOR SYSTEM]

## 2. CHECK VOLTAGE REAR CAMERA POWER SUPPLY

1. Connect around view monitor control unit connector and rear camera connector.
2. Turn ignition switch ON.
3. Check voltage between around view monitor control unit harness connector and ground.

Terminals		Voltage (Approx.)
(+)	(-)	
Around view monitor control unit		6.0 V
Connector	Terminal	
B51	50	
		Ground

Is the inspection result normal?

YES >> GO TO 3.

NO >> Replace around view monitor control unit. Refer to [AV-647, "Removal and Installation"](#).

## 3. CHECK CONTINUITY REAR CAMERA IMAGE SIGNAL CIRCUIT

1. Turn ignition switch OFF.
2. Disconnect around view monitor control unit connector and rear camera connector.
3. Check continuity between around view monitor control unit harness connector and rear camera harness connector.

Around view monitor control unit		Rear camera		Continuity
Connector	Terminal	Connector	Terminal	
B51	53	T50	5	Existed
	54		1	

4. Check continuity between around view monitor control unit harness connector and ground.

Around view monitor control unit		Ground	Continuity
Connector	Terminal		
B51	53		Not existed
	54		

Is the inspection result normal?

YES >> GO TO 4.

NO >> Repair harness or connector.

## 4. CHECK REAR CAMERA IMAGE SIGNAL

1. Connect around view monitor control unit connector and rear camera connector.
2. Turn ignition switch ON.
3. Check signal between around view monitor control unit harness connector.

# U111A REAR CAMERA IMAGE SIGNAL CIRCUIT

< DTC/CIRCUIT DIAGNOSIS >

[AROUND VIEW MONITOR SYSTEM]

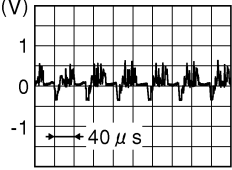
Around view monitor control unit			Condition	Reference value
Connector	Terminals			
	(+)	(-)		
Terminal				
B51	53	54	"CAMERA" switch is ON or shift position is "R".	 <p style="text-align: right; font-size: small;">JSNIA0834GB</p>

Is the inspection result normal?

- YES >> Replace around view monitor control unit. Refer to [AV-647, "Removal and Installation"](#).
- NO >> Replace rear camera. Refer to [AV-651, "Removal and Installation"](#).

A  
B  
C  
D  
E  
F  
G  
H  
I  
J  
K  
L  
M  
O  
P

AV

# U111B SIDE CAMERA RH IMAGE SIGNAL CIRCUIT

< DTC/CIRCUIT DIAGNOSIS >

[AROUND VIEW MONITOR SYSTEM]

## U111B SIDE CAMERA RH IMAGE SIGNAL CIRCUIT

### DTC Description

INFOID:000000013717556

### DTC DETECTION LOGIC

DTC	CONSULT screen terms (Trouble diagnosis content)	DTC detection condition	
U111B	SIDE CAMERA RH IMAGE SIGNAL (Side camera right image signal)	Diagnosis condition	When ignition switch is ON
		Signal (terminal)	Side camera RH image signal
		Threshold	Open or shorted
		Diagnosis delay time	30 seconds or more

### POSSIBLE CAUSE

Side camera RH image signal circuit

### FAIL-SAFE

Camera image is not displayed (Gray screen display)

### DTC CONFIRMATION PROCEDURE

#### 1. PERFORM DTC CONFIRMATION PROCEDURE

##### Ⓟ With CONSULT

1. Turn ignition switch ON.
2. Turn ignition switch OFF and wait at least 30 seconds.
3. Turn ignition switch ON and wait at least 30 seconds or more.
4. Select "Self Diagnostic Result" mode of "AVM" using CONSULT.
5. Check DTC.

##### Is DTC U111B detected?

YES >> Proceed to [AV-610. "Diagnosis Procedure"](#).

NO-1 >> To check malfunction symptom before repair: [GI-44. "Intermittent Incident"](#).

NO-2 >> Confirmation after repair: INSPECTION END

### Diagnosis Procedure

INFOID:000000013717557

#### 1. CHECK CONTINUITY SIDE CAMERA RH POWER SUPPLY AND GROUND CIRCUIT

1. Turn ignition switch OFF.
2. Disconnect around view monitor control unit connector and door mirror (passenger side) connector.
3. Check continuity between around view monitor control unit harness connector and door mirror (passenger side) harness connector.

Around view monitor control unit		Door mirror (passenger side)		Continuity
Connector	Terminal	Connector	Terminal	
B51	62	D65	15	Existed
	64		13	

4. Check continuity between door mirror (passenger side) connector harness connector and ground.

Door mirror (passenger side)		Ground	Continuity
Connector	Terminal		
D65	15		Not existed
	13		

##### Is the inspection result normal?

YES >> GO TO 2.

# U111B SIDE CAMERA RH IMAGE SIGNAL CIRCUIT

[AROUND VIEW MONITOR SYSTEM]

< DTC/CIRCUIT DIAGNOSIS >

NO >> Repair harness or connector.

## 2. CHECK VOLTAGE SIDE CAMERA RH POWER SUPPLY

1. Connect around view monitor control unit connector and door mirror (passenger side) connector.
2. Turn ignition switch ON.
3. Check voltage between around view monitor control unit harness connector and ground.

Terminals		(-)	Voltage (Approx.)
(+)			
Connector	Terminal		
B51	62	Ground	6.0 V

Is the inspection result normal?

YES >> GO TO 3.

NO >> Replace around view monitor control unit. Refer to [AV-647, "Removal and Installation"](#).

## 3. CHECK CONTINUITY SIDE CAMERA RH IMAGE SIGNAL CIRCUIT

1. Turn ignition switch OFF.
2. Disconnect around view monitor control unit connector and door mirror (passenger side) connector.
3. Check continuity between around view monitor control unit harness connector and door mirror (passenger side) harness connector.

Around view monitor control unit		Door mirror (passenger side)		Continuity
Connector	Terminal	Connector	Terminal	
B51	65	D65	14	Existed
	66		12	

4. Check continuity between around view monitor control unit harness connector and ground.

Around view monitor control unit		Ground	Continuity
Connector	Terminal		
B51	65		Ground
	66		

Is the inspection result normal?

YES >> GO TO 4.

NO >> Repair harness or connector.

## 4. CHECK SIDE CAMERA RH IMAGE SIGNAL

1. Connect around view monitor control unit connector and door mirror (passenger side) connector.
2. Turn ignition switch ON.
3. Check signal between around view monitor control unit harness connector.

A  
B  
C  
D  
E  
F  
G  
H  
I  
J  
K  
L  
M  
O  
P

AV

# U111B SIDE CAMERA RH IMAGE SIGNAL CIRCUIT

< DTC/CIRCUIT DIAGNOSIS >

[AROUND VIEW MONITOR SYSTEM]

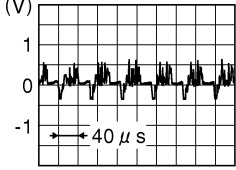
Around view monitor control unit			Condition	Reference value
Connector	Terminals			
	(+)	(-)		
Terminal				
B51	65	66	"CAMERA" switch is ON or shift position is "R".	 <p style="text-align: right; font-size: small;">JSNIA0834GB</p>

Is the inspection result normal?

- YES >> Replace around view monitor control unit. Refer to [AV-647, "Removal and Installation"](#).
- NO >> Replace side camera RH. Refer to [AV-650, "Removal and Installation"](#).

# U111C FRONT CAMERA IMAGE SIGNAL CIRCUIT

< DTC/CIRCUIT DIAGNOSIS >

[AROUND VIEW MONITOR SYSTEM]

## U111C FRONT CAMERA IMAGE SIGNAL CIRCUIT

### DTC Description

INFOID:000000013717558

### DTC DETECTION LOGIC

DTC	CONSULT screen terms (Trouble diagnosis content)	DTC detection condition	
		Diagnosis condition	When ignition switch is ON
U111C	FRONT CAMERA IMAGE SIGNAL (Front camera image signal)	Signal (terminal)	Front camera image signal
		Threshold	Open or shorted
		Diagnosis delay time	30 seconds or more

### POSSIBLE CAUSE

Front camera image signal circuit

### FAIL-SAFE

Camera image is not displayed (Gray screen display)

### DTC CONFIRMATION PROCEDURE

#### 1. PERFORM DTC CONFIRMATION PROCEDURE

Ⓜ With CONSULT

- Turn ignition switch ON.
- Turn ignition switch OFF and wait at least 30 seconds.
- Turn ignition switch ON and wait at least 30 seconds or more.
- Select "Self Diagnostic Result" mode of "AVM" using CONSULT.
- Check DTC.

Is DTC U111C detected?

YES >> Proceed to [AV-613, "Diagnosis Procedure"](#).

NO-1 >> To check malfunction symptom before repair: [GI-44, "Intermittent Incident"](#)

NO-2 >> Confirmation after repair: INSPECTION END

### Diagnosis Procedure

INFOID:000000013717559

#### 1. CHECK CONTINUITY FRONT CAMERA POWER SUPPLY AND GROUND CIRCUIT

- Turn ignition switch OFF.
- Disconnect around view monitor control unit connector and front camera connector.
- Check continuity between around view monitor control unit harness connector and front camera harness connector.

Around view monitor control unit		Front camera		Continuity
Connector	Terminal	Connector	Terminal	
B51	68	E116	1	Existed
	70		2	

- Check continuity between front camera harness connector and ground.

Front camera		Ground	Continuity
Connector	Terminal		
E116	1		Not existed
	2		

Is the inspection result normal?

YES >> GO TO 2.

NO >> Repair harness or connector.

# U111C FRONT CAMERA IMAGE SIGNAL CIRCUIT

< DTC/CIRCUIT DIAGNOSIS >

[AROUND VIEW MONITOR SYSTEM]

## 2. CHECK VOLTAGE FRONT CAMERA POWER SUPPLY

1. Connect around view monitor control unit connector and front camera connector.
2. Turn ignition switch ON.
3. Check voltage between around view monitor control unit harness connector.

Around view monitor control unit		Voltage (Approx.)
Connector	Terminals	
	(+)      (-)	
Terminal		
B51	68      70	6.0 V

Is the inspection result normal?

YES >> GO TO 3.

NO >> Replace around view monitor control unit. Refer to [AV-647, "Removal and Installation"](#).

## 3. CHECK CONTINUITY FRONT CAMERA IMAGE SIGNAL CIRCUIT

1. Turn ignition switch OFF.
2. Disconnect around view monitor control unit connector and front camera connector.
3. Check continuity between around view monitor control unit harness connector and front camera harness connector.

Around view monitor control unit		Front camera		Continuity
Connector	Terminal	Connector	Terminal	
B51	71	E116	3	Existed
	72		4	

4. Check continuity between around view monitor control unit harness connector and ground.

Around view monitor control unit		Ground	Continuity
Connector	Terminal		
B51	71		Ground
	72		

Is the inspection result normal?

YES >> GO TO 4.

NO >> Repair harness or connector.

## 4. CHECK FRONT CAMERA IMAGE SIGNAL

1. Connect around view monitor control unit connector and front camera connector.
2. Turn ignition switch ON.
3. Check signal between around view monitor control unit harness connector.

# U111C FRONT CAMERA IMAGE SIGNAL CIRCUIT

< DTC/CIRCUIT DIAGNOSIS >

[AROUND VIEW MONITOR SYSTEM]

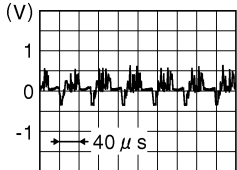
Around view monitor control unit		Condition	Reference value	
Connector	Terminals			
	(+)			(-)
Terminal				
B51	71	72	<p style="text-align: center;">“CAMERA” switch is ON or shift position is “R”.</p> <div style="text-align: right;">  <p style="font-size: small;">JSNIA0834GB</p> </div>	

Is the inspection result normal?

- YES >> Replace around view monitor control unit. Refer to [AV-647, "Removal and Installation"](#).
- NO >> Replace front camera. Refer to [AV-649, "Removal and Installation"](#).

A  
B  
C  
D  
E  
F  
G  
H  
I  
J  
K  
L  
M  
O  
P

AV

# U111D SIDE CAMERA LH IMAGE SIGNAL CIRCUIT

< DTC/CIRCUIT DIAGNOSIS >

[AROUND VIEW MONITOR SYSTEM]

## U111D SIDE CAMERA LH IMAGE SIGNAL CIRCUIT

### DTC Description

INFOID:000000013717560

### DTC DETECTION LOGIC

DTC	CONSULT screen terms (Trouble diagnosis content)	DTC detection condition	
		Diagnosis condition	When ignition switch is ON
U111D	SIDE CAMERA LH IMAGE SIGNAL (Side camera left image signal)	Signal (terminal)	Side camera LH image signal
		Threshold	Open or shorted
		Diagnosis delay time	30 seconds or more

### POSSIBLE CAUSE

Side camera LH image signal circuit

### FAIL-SAFE

Camera image is not displayed (Gray screen display).

### DTC CONFIRMATION PROCEDURE

#### 1. PERFORM DTC CONFIRMATION PROCEDURE

##### Ⓟ With CONSULT

1. Turn ignition switch ON.
2. Turn ignition switch OFF and wait at least 30 seconds.
3. Turn ignition switch ON and wait at least 30 seconds or more.
4. Select "Self Diagnostic Result" mode of "AVM" using CONSULT.
5. Check DTC.

##### Is DTC U111D detected?

YES >> Proceed to [AV-616. "Diagnosis Procedure"](#).

NO-1 >> To check malfunction symptom before repair: [GI-44. "Intermittent Incident"](#).

NO-2 >> Confirmation after repair: INSPECTION END

### Diagnosis Procedure

INFOID:000000013717561

#### 1. CHECK CONTINUITY SIDE CAMERA LH POWER SUPPLY AND GROUND CIRCUIT

1. Turn ignition switch OFF.
2. Disconnect around view monitor control unit connector and door mirror (driver side) connector.
3. Check continuity between around view monitor control unit harness connector and door mirror (driver side) harness connector.

Around view monitor control unit		Door mirror (driver side)		Continuity
Connector	Terminal	Connector	Terminal	
B51	56	D62	15	Existed
	58		13	

4. Check continuity between around view monitor control unit harness connector and ground.

Door mirror (driver side)		Ground	Continuity
Connector	Terminal		
D62	15		Not existed
	13		

##### Is the inspection result normal?

YES >> GO TO 2.

NO >> Repair harness or connector.

# U111D SIDE CAMERA LH IMAGE SIGNAL CIRCUIT

< DTC/CIRCUIT DIAGNOSIS >

[AROUND VIEW MONITOR SYSTEM]

## 2. CHECK VOLTAGE SIDE CAMERA LH POWER SUPPLY

1. Connect around view monitor control unit connector and door mirror (driver side) connector.
2. Turn ignition switch ON.
3. Check voltage between around view monitor control unit harness connector and ground.

Around view monitor control unit		Voltage (Approx.)
Connector	Terminals	
	(+)      (-)	
Terminal		
B51	56      58	6.0 V

Is the inspection result normal?

YES >> GO TO 3.

NO >> Replace around view monitor control unit. Refer to [AV-647, "Removal and Installation"](#).

## 3. CHECK CONTINUITY SIDE CAMERA LH IMAGE SIGNAL CIRCUIT

1. Turn ignition switch OFF.
2. Disconnect around view monitor control unit connector and door mirror (driver side) connector.
3. Check continuity between around view monitor control unit harness connector and door mirror (driver side) harness connector.

Around view monitor control unit		Door mirror (driver side)		Continuity
Connector	Terminals	Connector	Terminals	
B51	59	D62	14	Existed
	60		12	

4. Check continuity between around view monitor control unit harness connector and ground.

Around view monitor control unit		Ground	Continuity
Connector	Terminals		
B51	59		Not existed
	60		

Is the inspection result normal?

YES >> GO TO 4.

NO >> Repair harness or connector.

## 4. CHECK SIDE CAMERA LH IMAGE SIGNAL

1. Connect around view monitor control unit connector and door mirror (driver side) connector.
2. Turn ignition switch ON.
3. Check signal between around view monitor control unit harness connector.

A  
B  
C  
D  
E  
F  
G  
H  
I  
J  
K  
L  
M  
O  
P

AV

# U111D SIDE CAMERA LH IMAGE SIGNAL CIRCUIT

< DTC/CIRCUIT DIAGNOSIS >

[AROUND VIEW MONITOR SYSTEM]

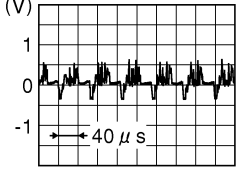
Around view monitor control unit			Condition	Reference value
Connector	Terminals			
	(+)	(-)		
Terminal				
B51	59	60	"CAMERA" switch is ON or shift position is "R".	 <p style="text-align: right; font-size: small;">JSNIA0834GB</p>

Is the inspection result normal?

- YES >> Replace around view monitor control unit. Refer to [AV-647, "Removal and Installation"](#).
- NO >> Replace side camera LH. Refer to [AV-650, "Removal and Installation"](#).

# U1232 STEERING ANGLE SENSOR

< DTC/CIRCUIT DIAGNOSIS >

[AROUND VIEW MONITOR SYSTEM]

## U1232 STEERING ANGLE SENSOR

### DTC Description

INFOID:000000013717562

### DESCRIPTION

Steering angle sensor is connected to the display control unit and transmits the steering angle signal via CAN communication.

### DTC DETECTION LOGIC

DTC No.	CONSULT screen terms (Trouble diagnosis content)	DTC detection condition	
		Diagnosis condition	When ignition switch is ON
U1232	ST ANGLE SEN CALIB (Steering angle sensor calibration)	Signal (terminal)	—
		Threshold	The neutral position registration of the steering angle sensor can not finish.
		Diagnosis delay time	30 seconds or more

### POSSIBLE CAUSE

Predictive course line center position adjustment of the steering angle sensor is incomplete

### FAIL-SAFE

- Predicted course line is not displayed
- MOD (Moving Object Detection) function is stopped
- Tire icon is stopped
- Using "SETTING" menu display, switch each indicator of predicted course line display and MOD switch to "OFF" (turn OFF) so that switch operation cannot be performed

### DTC CONFIRMATION PROCEDURE

#### 1. PERFORM DTC CONFIRMATION PROCEDURE

##### Ⓜ With CONSULT

1. Turn ignition switch ON.
2. Turn ignition switch OFF and wait at least 30 seconds.
3. Turn ignition switch ON and wait at least 30 seconds or more.
4. Select "Self Diagnostic Result" mode of "AVM" using CONSULT.
5. Check DTC.

##### Is DTC U1232 detected?

- YES >> Proceed to [AV-619, "Diagnosis Procedure"](#).  
NO-1 >> To check malfunction symptom before repair: [GI-44, "Intermittent Incident"](#).  
NO-2 >> Confirmation after repair: INSPECTION END

### Diagnosis Procedure

INFOID:000000013717563

#### 1. ADJUST THE PREDICTIVE COURSE LINE CENTER POSITION OF THE STEERING ANGLE SENSOR

Adjusts the steering angle sensor neutral position on ABS actuator and electrical unit (control unit) side. Refer to [BRC-92, "Description"](#).

##### NOTE:

When DTC U1232 is detected, adjust the predictive course line center position of the steering angle sensor.

>> GO TO 2.

#### 2. PERFORM DTC CONFIRMATION PROCEDURE AGAIN

Perform DTC confirmation procedure again. Refer to [AV-619, "DTC Description"](#).

##### Is DTC U1232 detected again?

- YES >> Replace steering angle sensor. Refer to [AV-659, "Removal and Installation"](#).  
NO >> INSPECTION END

# U1302 CAMERA POWER VOLT

< DTC/CIRCUIT DIAGNOSIS >

[AROUND VIEW MONITOR SYSTEM]

## U1302 CAMERA POWER VOLT

### DTC Description

INFOID:000000013717564

### DTC DETECTION LOGIC

DTC No.	CONSULT screen terms (Trouble diagnosis content)	DTC detection condition	
U1302	CAMERA POWER VOLT (Camera power voltage)	Diagnosis condition	When ignition switch is ON
		Signal (terminal)	Camera power supply voltage
		Threshold	0 V
		Diagnosis delay time	2 seconds or more

### POSSIBLE CAUSE

- Short circuit to battery or short circuit to ground of camera power supply output circuit.
- Around view monitor control unit

### FAIL-SAFE

Camera power output is stopped

### DTC CONFIRMATION PROCEDURE

#### 1. PERFORM DTC CONFIRMATION PROCEDURE

④ With CONSULT

1. Turn ignition switch ON.
2. Turn ignition switch OFF and wait at least 30 seconds.
3. Turn ignition switch ON and wait at least 2 seconds or more.
4. Select "Self Diagnostic Result" mode of "AVM" using CONSULT.
5. Check DTC.

Is DTC U1302 detected?

- YES >> Proceed to [AV-620. "Diagnosis Procedure"](#).  
NO-1 >> To check malfunction symptom before repair: [GI-44. "Intermittent Incident"](#).  
NO-2 >> Confirmation after repair: INSPECTION END

### Diagnosis Procedure

INFOID:000000013717565

#### 1. CHECK AROUND VIEW MONITOR CONTROL UNIT POWER SUPPLY AND GROUND CIRCUIT

Check around view monitor control unit power supply and ground circuit. Refer to [AV-627. "AROUND VIEW MONITOR CONTROL UNIT : Diagnosis Procedure"](#).

Is the inspection result normal?

- YES >> GO TO 2.  
NO >> Repair malfunctioning parts.

#### 2. CHECK REAR CAMERA POWER SUPPLY OUTPUT CIRCUIT (CHECK FOR SHORT CIRCUIT)

1. Disconnect around view monitor control unit connector and rear camera connector.
2. Check whether or not continuity between around view monitor control unit harness connector and ground is normal.

Around view monitor control unit		Ground	Continuity
Connector	Terminal		
B51	50		Not existed

Is the inspection result normal?

- YES >> GO TO 3.  
NO >> Repair the harnesses or connectors.

#### 3. CHECK REAR CAMERA POWER SUPPLY 1

# U1302 CAMERA POWER VOLT

[AROUND VIEW MONITOR SYSTEM]

< DTC/CIRCUIT DIAGNOSIS >

1. Connect around view monitor control unit connector.
2. Turn ignition switch ON.
3. Check whether or not voltage between around view monitor control unit harness connectors is normal.

Around view monitor control unit			Reference value (Approx.)
Connector	Terminals		
	(+)	(-)	
	Terminal		
B51	50	52	6.0 V

Is the inspection result normal?

YES >> GO TO 4.

NO >> Replace around view monitor control unit. Refer to [AV-647. "Removal and Installation"](#).

## 4.CHECK REAR CAMERA POWER SUPPLY 2

1. Turn ignition switch OFF.
2. Connect rear camera connector.
3. Turn ignition switch ON.
4. Check whether or not voltage between around view monitor control unit harness connectors is normal.

Around view monitor control unit			Reference value (Approx.)
Connector	Terminals		
	(+)	(-)	
	Terminal		
B51	50	52	6.0 V

Is the inspection result normal?

YES >> GO TO 5.

NO >> Replace rear camera. Refer to [AV-651. "Removal and Installation"](#).

## 5.CHECK FRONT CAMERA POWER SUPPLY OUTPUT CIRCUIT (CHECK FOR SHORT CIRCUIT)

1. Turn ignition switch OFF.
2. Disconnect around view monitor control unit connector and front camera connector.
3. Check whether or not continuity between around view monitor control unit harness connector and ground is normal.

Around view monitor control unit		Ground	Continuity
Connector	Terminal		
B51	68		Not existed

Is the inspection result normal?

YES >> GO TO 6.

NO >> Repair the harnesses or connectors.

## 6.CHECK FRONT CAMERA POWER SUPPLY 1

1. Connect around view monitor control unit connector.
2. Turn ignition switch ON.
3. Check whether or not voltage between around view monitor control unit harness connectors is normal.

Around view monitor control unit			Reference value (Approx.)
Connector	Terminals		
	(+)	(-)	
	Terminal		
B51	68	70	6.0 V

Is the inspection result normal?

A  
B  
C  
D  
E  
F  
G  
H  
I  
J  
K  
L  
M  
O  
P

AV

# U1302 CAMERA POWER VOLT

[AROUND VIEW MONITOR SYSTEM]

< DTC/CIRCUIT DIAGNOSIS >

YES >> GO TO 7.

NO >> Replace around view monitor control unit. Refer to [AV-647, "Removal and Installation"](#).

## 7. CHECK FRONT CAMERA POWER SUPPLY 2.

1. Turn ignition switch OFF.
2. Connect front camera connector.
3. Turn ignition switch ON.
4. Check whether or not voltage between around view monitor control unit harness connectors is normal.

Around view monitor control unit			Reference value (Approx.)
Connector	Terminals		
	(+)	(-)	
Terminal			
B51	68	70	6.0 V

Is the inspection result normal?

YES >> GO TO 8.

NO >> Replace front camera. Refer to [AV-649, "Removal and Installation"](#).

## 8. CHECK SIDE CAMERA RH POWER SUPPLY OUTPUT CIRCUIT (CHECK FOR SHORT CIRCUIT)

1. Turn ignition switch OFF.
2. Disconnect around view monitor control unit connector and door mirror (driver side) connector.
3. Check whether or not continuity between around view monitor control unit harness connector and ground is normal.

Around view monitor control unit		Ground	Continuity
Connector	Terminal		
B51	62		Not existed

Is the inspection result normal?

YES >> GO TO 9.

NO >> Repair the harnesses or connectors.

## 9. CHECK SIDE CAMERA RH POWER SUPPLY 1

1. Connect around view monitor control unit connector.
2. Turn ignition switch ON.
3. Check whether or not voltage between around view monitor control unit harness connectors is normal.

Around view monitor control unit			Reference value (Approx.)
Connector	Terminals		
	(+)	(-)	
Terminal			
B51	62	64	6.0 V

Is the inspection result normal?

YES >> GO TO 10.

NO >> Replace around view monitor control unit. Refer to [AV-647, "Removal and Installation"](#).

## 10. CHECK SIDE CAMERA RH POWER SUPPLY 2

1. Turn ignition switch OFF.
2. Connect door mirror (driver side) connector.
3. Turn ignition switch ON.
4. Check whether or not voltage between around view monitor control unit harness connectors is normal.

# U1302 CAMERA POWER VOLT

< DTC/CIRCUIT DIAGNOSIS >

[AROUND VIEW MONITOR SYSTEM]

Around view monitor control unit			Reference value (Approx.)
Connector	Terminals		
	(+)	(-)	
	Terminal		
B51	62	64	6.0 V

Is the inspection result normal?

YES >> GO TO 11.

NO >> Replace side camera RH. Refer to [AV-650, "Removal and Installation"](#).

## 11. CHECK SIDE CAMERA LH POWER SUPPLY OUTPUT CIRCUIT (CHECK FOR SHORT CIRCUIT)

1. Turn ignition switch OFF.
2. Disconnect around view monitor control unit connector and door mirror (passenger side) connector.
3. Check whether or not continuity between around view monitor control unit harness connector and ground is normal.

Around view monitor control unit		Ground	Continuity
Connector	Terminal		
B51	56		Not existed

Is the inspection result normal?

YES >> GO TO 12.

NO >> Repair the harnesses or connectors.

## 12. CHECK SIDE CAMERA LH POWER SUPPLY 1

1. Connect around view monitor control unit connector.
2. Turn ignition switch ON.
3. Check whether or not voltage between around view monitor control unit harness connectors is normal.

Around view monitor control unit			Reference value (Approx.)
Connector	Terminals		
	(+)	(-)	
	Terminal		
B51	56	58	6.0 V

Is the inspection result normal?

YES >> GO TO 13.

NO >> Replace around view monitor control unit. Refer to [AV-647, "Removal and Installation"](#).

## 13. CHECK SIDE CAMERA LH POWER SUPPLY 2

1. Turn ignition switch OFF.
2. Connect door mirror (passenger side) connector.
3. Turn ignition switch ON.
4. Check whether or not voltage between around view monitor control unit harness connectors is normal.

Around view monitor control unit			Reference value (Approx.)
Connector	Terminals		
	(+)	(-)	
	Terminal		
B51	56	58	6.0 V

Is the inspection result normal?

YES >> Replace around view monitor control unit. Refer to [AV-647, "Removal and Installation"](#).

NO >> Replace side camera LH. Refer to [AV-650, "Removal and Installation"](#).

A  
B  
C  
D  
E  
F  
G  
H  
I  
J  
K  
L  
M  
O  
P

AV

# U1303 LED POWER SUPPLY VOLT

< DTC/CIRCUIT DIAGNOSIS >

[AROUND VIEW MONITOR SYSTEM]

## U1303 LED POWER SUPPLY VOLT

### DTC Description

INFOID:000000013717566

### DTC DETECTION LOGIC

DTC No.	CONSULT screen terms (Trouble diagnosis content)	DTC detection condition	
U1303	LED POWER SUPPLY VOLT (LED power supply voltage)	Diagnosis condition	When ignition switch is ON
		Signal (terminal)	Lighting supply voltage
		Threshold	5.2 - 5.8 V
		Diagnosis delay time	2 seconds or more

#### NOTE:

This vehicle is equipped with a supplemental lighting supply output circuit but not a supplemental light

#### POSSIBLE CAUSE

- Short circuit to battery or short circuit to ground of supplemental lighting output circuit
- Around view monitor control unit

#### FAIL-SAFE

None

#### DTC CONFIRMATION PROCEDURE

##### 1. PERFORM DTC CONFIRMATION PROCEDURE

###### Ⓜ With CONSULT

1. Turn ignition switch ON.
2. Turn ignition switch OFF and wait at least 30 seconds.
3. Turn ignition switch ON and wait at least 2 seconds or more.
4. Select "Self Diagnostic Result" mode of "AVM" using CONSULT.
5. Check DTC.

###### Is DTC U1303 detected?

- YES >> Proceed to [AV-624, "Diagnosis Procedure"](#).
- NO-1 >> To check malfunction symptom before repair: [GI-44, "Intermittent Incident"](#).
- NO-2 >> Confirmation after repair: INSPECTION END

#### Diagnosis Procedure

INFOID:000000013717567

##### 1. DTC CONFIRMATION PROCEDURE AGAIN

###### Ⓜ With CONSULT

1. Turn ignition switch ON.
2. Erase DTC.
3. Perform DTC confirmation procedure again. Refer to [AV-624, "DTC Description"](#).

###### Is DTC U1303 detected again?

- YES >> Replace around view monitor control unit. Refer to [AV-647, "Removal and Installation"](#).
- NO >> INSPECTION END

# U1304 CAMERA IMAGE CALIBRATION

< DTC/CIRCUIT DIAGNOSIS >

[AROUND VIEW MONITOR SYSTEM]

## U1304 CAMERA IMAGE CALIBRATION

### DTC Description

INFOID:000000013717568

### DTC DETECTION LOGIC

DTC No.	CONSULT screen terms (Trouble diagnosis content)	DTC detection condition	
U1304	CAMERA IMAGE CALIB (Camera image calibration)	Diagnosis condition	When ignition switch is ON
		Signal (terminal)	—
		Threshold	Camera calibration is incomplete
		Diagnosis delay time	2 seconds or more

### POSSIBLE CAUSE

Camera calibration is incomplete

### FAIL-SAFE

Unmatched icon  display (red) is displayed (applicable for unmatched camera only)

### DTC CONFIRMATION PROCEDURE

#### 1. PERFORM DTC CONFIRMATION PROCEDURE

Ⓜ With CONSULT

1. Turn ignition switch ON.
2. Turn ignition switch OFF and wait at least 30 seconds.
3. Turn ignition switch ON and wait at least 2 seconds or more.
4. Select "Self Diagnostic Result" mode of "AVM" using CONSULT.
5. Check DTC.

Is DTC U1304 detected?

- YES >> Proceed to [AV-625. "Diagnosis Procedure"](#).  
NO-1 >> To check malfunction symptom before repair: [GI-44. "Intermittent Incident"](#).  
NO-2 >> Confirmation after repair: INSPECTION END

### Diagnosis Procedure

INFOID:000000013717569

#### 1. PERFORM CALIBRATING CAMERA IMAGE

Perform camera calibration. Refer to [AV-566. "Description"](#).

>> GO TO 2.

#### 2. PERFORM DTC CONFIRMATION PROCEDURE AGAIN

Perform DTC confirmation procedure again. Refer to [AV-625. "DTC Description"](#).

Is DTC U1304 detected again?

- YES >> Replace malfunctioning camera.  
NO >> INSPECTION END

A  
B  
C  
D  
E  
F  
G  
H  
I  
J  
K  
L  
M  
AV  
O  
P

# U1305 CONFIG UNFINISH

< DTC/CIRCUIT DIAGNOSIS >

[AROUND VIEW MONITOR SYSTEM]

## U1305 CONFIG UNFINISH

### DTC Description

INFOID:000000013717570

### DTC DETECTION LOGIC

DTC No.	CONSULT screen terms (Trouble diagnosis content)	DTC detection condition	
U1305	CONFIG UNFINISH (Configuration unfinish)	Diagnosis condition	When ignition switch is ON
		Signal (terminal)	—
		Threshold	Configuration is incomplete
		Diagnosis delay time	2 seconds or more

### POSSIBLE CAUSE

The vehicle setting of around view monitor control unit is incomplete

### FAIL-SAFE

Operation is according to the vehicle setting value as default value

### DTC CONFIRMATION PROCEDURE

#### 1.PERFORM DTC CONFIRMATION PROCEDURE

##### Ⓢ With CONSULT

1. Turn ignition switch ON.
2. Turn ignition switch OFF and wait at least 30 seconds.
3. Turn ignition switch ON and wait at least 2 seconds or more.
4. Select "Self Diagnostic Result" mode of "AVM" using CONSULT.
5. Check DTC.

##### Is DTC U1305 detected?

- YES >> Proceed to [AV-626. "Diagnosis Procedure"](#).  
NO-1 >> To check malfunction symptom before repair: [GI-44. "Intermittent Incident"](#).  
NO-2 >> Confirmation after repair: INSPECTION END

### Diagnosis Procedure

INFOID:000000013717571

#### 1.PERFORM CONFIGURATION OF AROUND VIEW MONITOR CONTROL UNIT

Perform configuration of around view monitor control unit. Refer to [AV-563. "Work Procedure"](#).

>> GO TO 2.

#### 2.PERFORM DTC CONFIRMATION PROCEDURE AGAIN

Perform DTC confirmation procedure again. Refer to [AV-626. "DTC Description"](#).

##### Is DTC U1305 detected again?

- YES >> Replace around view monitor control unit. Refer to [AV-647. "Removal and Installation"](#).  
NO >> INSPECTION END

# POWER SUPPLY AND GROUND CIRCUIT

< DTC/CIRCUIT DIAGNOSIS >

[AROUND VIEW MONITOR SYSTEM]

## POWER SUPPLY AND GROUND CIRCUIT AROUND VIEW MONITOR CONTROL UNIT

### AROUND VIEW MONITOR CONTROL UNIT : Diagnosis Procedure

INFOID:000000013717572

#### 1. CHECK FUSE

1. Turn ignition switch OFF.
2. Check that the following fuse is not blown (open).

VR30DDTT engine

Power source	Fuse No.	Capacity
Battery	#7	15 A
Ignitions switch ACC	#1	10 A
Ignition switch ON	#14	5 A

2.0L turbo gasoline engine

Power source	Fuse No.	Capacity
Battery	#84	15 A
Ignitions switch ACC	#93	10 A
Ignition switch ON	#77	10 A

Is the fuse blown (open)?

YES >> Replace fuse after repairing the applicable circuit.

NO >> GO TO 2.

#### 2. CHECK POWER SUPPLY CIRCUITS

Check voltage between around view monitor control unit harness connector and ground.

Signal name	Terminals		Ignition switch position	Value (Approx.)	
	(+)				(-)
	Around view monitor control unit				
Connector	Terminal				
Battery power supply	B50	2	OFF	Battery voltage	
ACC power supply		4	ACC		
Ignition signal		3	ON		

Is inspection result normal?

YES >> GO TO 3.

NO >> Check harness between around view monitor control unit and fuse.

#### 3. CHECK GROUND CIRCUIT

1. Turn ignition switch OFF.
2. Disconnect around view monitor control unit connector.
3. Check continuity between around view monitor control unit harness connector and ground.

Terminals		Continuity	
(+)			(-)
Around view monitor control unit			
Connector	Terminal		
B50	1	Ground	Existed

Is inspection result normal?

YES >> INSPECTION END

NO >> Repair harness or connector.

A

B

C

D

E

F

G

H

I

J

K

L

M

AV

O

P

# POWER SUPPLY AND GROUND CIRCUIT

< DTC/CIRCUIT DIAGNOSIS >

[AROUND VIEW MONITOR SYSTEM]

## SONAR CONTROL UNIT

### SONAR CONTROL UNIT : Diagnosis Procedure

INFOID:000000013717573

#### 1. CHECK FUSE

1. Turn ignition switch OFF.
2. Check that the following fuse is not blown (open).

VR30DDTT engine

Power source	Fuse No.	Capacity
Ignition switch ON	#14	5 A

2.0L turbo gasoline engine

Power source	Fuse No.	Capacity
Ignition switch ON	#77	10 A

Is the fuse blown (open)?

YES >> Replace fuse after repairing the applicable circuit.

NO >> GO TO 2.

#### 2. CHECK IGNITION POWER SUPPLY CIRCUIT

1. Turn ignition switch ON.
2. Check the voltage between sonar control unit harness connector and ground.

Terminals		(-)	Voltage
(+)			
Sonar control unit		Ground	Battery voltage
Connector	Terminal		
M76	12		

Is the inspection result normal?

YES >> GO TO 3.

NO >> Repair sonar control unit power supply harness.

#### 3. CHECK GROUND CIRCUIT

1. Turn ignition switch OFF.
2. Disconnect sonar control unit harness connector.
3. Check the continuity between sonar control unit harness connector and ground.

Terminals		(-)	Continuity
(+)			
Sonar control unit		Ground	Existed
Connector	Terminal		
M76	15		

Is the inspection result normal?

YES >> INSPECTION END

NO >> Repair sonar control unit ground harness.

# CAMERA IMAGE SIGNAL CIRCUIT (WITH AROUND VIEW MONITOR)

< DTC/CIRCUIT DIAGNOSIS >

[AROUND VIEW MONITOR SYSTEM]

## CAMERA IMAGE SIGNAL CIRCUIT (WITH AROUND VIEW MONITOR)

### Description

INFOID:000000013717574

Around view monitor control unit supplies to the front camera, rear camera and side camera. And then it superimpose the images from each camera and outputs then to the display control unit.

### Diagnosis Procedure

INFOID:000000013717575

#### 1. CHECK CONTINUITY CAMERA IMAGE SIGNAL CIRCUIT FOR OPEN

1. Turn ignition switch OFF.
2. Disconnect display control unit harness connector and around view monitor control unit harness connector.
3. Check continuity between display control unit harness connector and around view monitor control unit harness connector.

Display control unit		Around view monitor control unit		Continuity
Connector	Terminal	Connector	Terminal	
M101	38	B51	48	Existed
	58		47	

Is the inspection result normal?

YES >> GO TO 2.

NO >> Repair or replace malfunctioning parts.

#### 2. CHECK CONTINUITY CAMERA IMAGE SIGNAL CIRCUIT FOR SHORT

Check continuity between display control unit harness connector and ground.

Display control unit		Ground	Continuity
Connector	Terminal		
M101	58		Not existed

Is the inspection result normal?

YES >> GO TO 3.

NO >> Repair or replace malfunctioning parts.

#### 3. CHECK CAMERA IMAGE SIGNAL

1. Connect display control unit harness connector and around view monitor control unit harness connector.
2. Turn ignition switch ON.
3. Check signal between display control unit harness connector and ground.

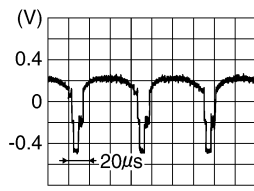
Terminals		(-)	Condition	Reference value
(+)				
Display control unit	Terminal			
Connector	Terminal			
M101	58	Ground	[Ignition switch ON] Image is displayed	

Is the inspection result normal?

YES >> Replace display control unit. Refer to [AV-431, "Removal and Installation"](#).

## CAMERA IMAGE SIGNAL CIRCUIT (WITH AROUND VIEW MONITOR)

< DTC/CIRCUIT DIAGNOSIS >

[AROUND VIEW MONITOR SYSTEM]

---

NO >> Replace around view monitor control unit. Refer to [AV-647. "Removal and Installation"](#).

# CAMERA SWITCH SIGNAL CIRCUIT

< DTC/CIRCUIT DIAGNOSIS >

[AROUND VIEW MONITOR SYSTEM]

## CAMERA SWITCH SIGNAL CIRCUIT

### Description

INFOID:000000013717576

- The camera switch signal is output to integral switch when the camera switch of multifunction switch is pressed.
- The integral switch transmits camera switch signal to the display control unit.
- The display control unit transmits camera switch signal via AV communication to the around view monitor control unit.

### Component Function Check

INFOID:000000013717577

#### 1. CHECK CAMERA SWITCH SIGNAL

Ⓜ With CONSULT

1. Turn ignition ON.
2. Select "CAMERA SWITCH SIGNAL" in "DATA MONITOR" mode of "AVM" using CONSULT.
3. Check "CAMERA SWITCH SIGNAL" indication as per the following condition.

Monitor item	Condition		Indication
CAMERA SWITCH SIGNAL	Camera switch	Press	On
		Except above	Off

Is the inspection result normal?

- YES >> INSPECTION END  
 NO >> Proceed to [AV-631, "Diagnosis Procedure"](#).

### Diagnosis Procedure

INFOID:000000013717578

#### 1. CHECK CAMERA SWITCH INPUT SIGNAL OF DISPLAY CONTROL UNIT

1. Turn ignition switch ON.
2. Check the voltage between display control unit harness connector and ground.

Terminals		(-)	Condition	Voltage (Approx.)
(+)				
Connector	Terminal			
M100	26	Ground	Camera switch ON	0 – 2.5 V
			Camera switch OFF	3.0 V

Is the inspection result normal?

- YES >> Replace display control unit. Refer to [AV-431, "Removal and Installation"](#).  
 NO >> GO TO 2.

#### 2. CHECK CAMERA SWITCH INPUT SIGNAL OF INTEGRAL SWITCH

Check the voltage between integral switch harness connector and ground.

Terminals		(-)	Condition	Voltage (Approx.)
(+)				
Connector	Terminal			
M1	19	Ground	Camera switch ON	0 – 2.5 V
			Camera switch OFF	3.0 V

Is the inspection result normal?

- YES >> GO TO 3.

A  
B  
C  
D  
E  
F  
G  
H  
I  
J  
K  
L  
M  
AV  
O  
P

# CAMERA SWITCH SIGNAL CIRCUIT

[AROUND VIEW MONITOR SYSTEM]

< DTC/CIRCUIT DIAGNOSIS >

NO >> GO TO 5.

## 3. CHECK CAMERA SWITCH INPUT SIGNAL CIRCUIT OF DISPLAY CONTROL UNIT FOR OPEN

1. Turn ignition switch OFF.
2. Disconnect display control unit harness connector and integral switch harness connector.
3. Check the continuity between display control unit harness connector and integral switch harness connector.

Display control unit		Integral switch		Continuity
Connector	Terminal	Connector	Terminal	
M100	26	M1	19	Existed

Is the inspection result normal?

YES >> GO TO 4.

NO >> Repair or replace malfunctioning parts.

## 4. CHECK CAMERA SWITCH INPUT SIGNAL CIRCUIT OF DISPLAY CONTROL UNIT FOR SHORT

Check the continuity between display control unit harness connector and ground.

Display control unit		Ground	Continuity
Connector	Terminal		
M100	26		Not existed

Is the inspection result normal?

YES >> Replace integral switch. Refer to [AV-435. "Removal and Installation"](#).

NO >> Repair or replace malfunctioning parts.

## 5. CHECK CAMERA SWITCH INPUT SIGNAL CIRCUIT OF INTEGRAL SWITCH FOR OPEN

1. Turn ignition switch OFF.
2. Disconnect integral switch harness connector and multifunction switch harness connector.
3. Check the continuity between integral switch harness connector and multifunction switch harness connector.

Integral switch		Multifunction switch		Continuity
Connector	Terminal	Connector	Terminal	
M3	39	M55	10	Existed

Is the inspection result normal?

YES >> GO TO 6.

NO >> Repair or replace malfunctioning parts.

## 6. CHECK CAMERA SWITCH INPUT SIGNAL CIRCUIT OF INTEGRAL SWITCH FOR SHORT

Check the continuity between integral switch harness connector and ground.

Integral switch		Ground	Continuity
Connector	Terminal		
M3	39		Not existed

Is the inspection result normal?

YES >> GO TO 7.

NO >> Repair or replace malfunctioning parts.

## 7. CHECK MULTIFUNCTION SWITCH

Check multifunction switch. Refer to [AV-633. "Component Inspection"](#).

Is the inspection result normal?

YES >> INSPECTION END

NO >> Replace multifunction switch. Refer to [AV-436. "Removal and Installation"](#).

# CAMERA SWITCH SIGNAL CIRCUIT

[AROUND VIEW MONITOR SYSTEM]

< DTC/CIRCUIT DIAGNOSIS >

INFOID:000000013717579

## Component Inspection

### 1. CHECK MULTIFUNCTION SWITCH (1)

1. Turn ignition switch OFF.
2. Disconnect multifunction switch harness connector.
3. Check the resistance between multifunction switch terminals as per the following condition.

Terminal		Switch position	Resistance (Ω)
(+)	(-)		
1		All OFF	4632 - 4868
		E	390.1 - 410.1
		F	45.3 - 47.7
4	2	All OFF	4632 - 4868
		A	605.1 - 636.2
		B	211.2 - 222.0
		G	45.3 - 47.7
10		All OFF	4632 - 4868
		C	605.1 - 636.2
		D	211.2 - 222.0
		H	45.3 - 47.7

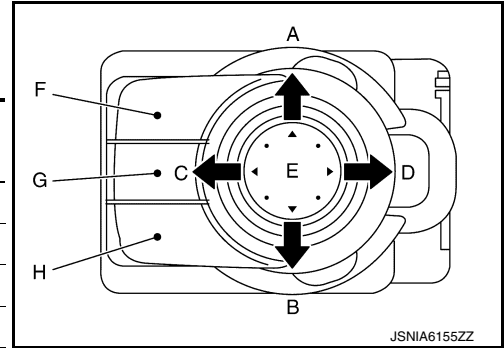

Is the inspection result normal?

YES >> GO TO 2.

NO >> Replace multifunction switch. Refer to [AV-436, "Removal and Installation"](#).

### 2. CHECK MULTIFUNCTION SWITCH (2)

1. Reconnect all harness connectors disconnected.
2. Turn ignition switch ON.
3. Check the voltage between integral switch harness connector terminals as per the following condition.

Integral switch			Condition		Voltage (Approx.)
Connector	Terminals				
	(+)	(-)			
	Terminal				
M3	32	31	Multifunction switch	Rotate	2.0 - 4.3 V
	37				

Is the inspection result normal?

YES >> INSPECTION END

NO >> Replace multifunction switch. Refer to [AV-436, "Removal and Installation"](#).

# FRONT CAMERA COMMUNICATION SIGNAL CIRCUIT

< DTC/CIRCUIT DIAGNOSIS >

[AROUND VIEW MONITOR SYSTEM]

## FRONT CAMERA COMMUNICATION SIGNAL CIRCUIT

### Description

INFOID:000000013717580

- Around view monitor control unit supplies to the front camera, rear camera and side camera. And then it superimpose the images from each camera and outputs then to the display control unit.
- Superimpose the guiding lines, predicted course line and sonar indicator to the camera image that outputs to the display control unit.
- Around view monitor control unit performs the reception/transmission of communication signal with each camera.

### Component Function Check

INFOID:000000013717581

#### 1. CHECK FRONT CAMERA COMMUNICATION STATUS

##### Ⓟ WITH CONSULT

1. Turn ignition switch ON.
2. Select "F-CAMERA COMM STATUS" in "DATA MONITOR" mode of "AVM" using CONSULT.
3. Check "F-CAMERA COMM STATUS" indication as per the following condition.

Monitor item	Condition	Indication
F-CAMERA COMM STATUS	Front camera image is displayed	OK

##### NOTE:

Refer to [AV-467. "System Description"](#) for around view monitor operation.

Is the inspection result normal?

YES >> INSPECTION END

NO >> Proceed to [AV-634. "Diagnosis Procedure"](#).

### Diagnosis Procedure

INFOID:000000013717582

#### 1. CHECK COMMUNICATION SIGNAL

1. Turn ignition switch ON.
2. Check the signal between around view monitor control unit harness connector and ground.

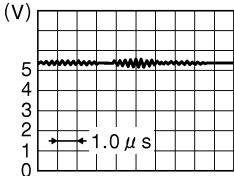
Terminals		(-)	Condition	Reference value
(+)				
Connector	Terminal			
B51	67	Ground	"CAMERA" switch is ON or shift position is "R".	 <p>(V)</p> <p>5 4 3 2 1 0</p> <p>← 1.0 μs</p> <p>JSNIA0836GB</p>

Is the inspection result normal?

YES >> Replace around view monitor control unit. Refer to [AV-647. "Removal and Installation"](#).

NO >> GO TO 2.

#### 2. CHECK CONTINUITY COMMUNICATION SIGNAL CIRCUIT FOR OPEN

1. Turn ignition switch OFF.
2. Disconnect around view monitor control unit harness connector and front camera harness connector.
3. Check the continuity between around view monitor control unit harness connector and front camera harness connector.

# FRONT CAMERA COMMUNICATION SIGNAL CIRCUIT

< DTC/CIRCUIT DIAGNOSIS >

[AROUND VIEW MONITOR SYSTEM]

Around view monitor control unit		Front camera		Continuity
Connector	Terminal	Connector	Terminal	
B51	67	E116	6	Existed

Is the inspection result normal?

YES >> GO TO 3.

NO >> Repair or replace malfunctioning parts.

## 3. CHECK CONTINUITY COMMUNICATION SIGNAL CIRCUIT FOR SHORT

Check the continuity between around view monitor control unit harness connector and ground.

Around view monitor control unit		Ground	Continuity
Connector	Terminal		
B51	67		Not existed

Is inspection result normal?

YES >> Replace front camera. Refer to [AV-649, "Removal and Installation"](#).

NO >> Repair or replace malfunctioning parts.

A  
B  
C  
D  
E  
F  
G  
H  
I  
J  
K  
L  
M  
O  
P

AV

# SIDE CAMERA LH COMMUNICATION SIGNAL CIRCUIT

< DTC/CIRCUIT DIAGNOSIS >

[AROUND VIEW MONITOR SYSTEM]

## SIDE CAMERA LH COMMUNICATION SIGNAL CIRCUIT

### Description

INFOID:000000013717583

- Around view monitor control unit supplies to the front camera, rear camera and side camera. And then it superimpose the images from each camera and outputs then to the front display unit.
- Superimpose the guiding lines, predicted course line and sonar indicator to the camera image that outputs to the front display unit.
- Around view monitor control unit performs the reception/transmission of communication signal with each camera.

### Component Function Check

INFOID:000000013717584

#### 1. CHECK SIDE CAMERA LH COMMUNICATION STATUS

##### Ⓜ WITH CONSULT

1. Turn ignition switch ON.
2. Select "DR-SIDE CAMERA COMM STATUS" in "DATA MONITOR" mode of "AVM" using CONSULT.
3. Check "DR-SIDE CAMERA COMM STATUS" indication as per the following condition.

Monitor item	Condition	Indication
DR-SIDE CAMERA COMM STATUS	Side camera LH image is displayed	OK

##### NOTE:

Refer to [AV-467. "System Description"](#) for around view monitor operation.

Is the inspection result normal?

YES >> INSPECTION END

NO >> Proceed to [AV-636. "Diagnosis Procedure"](#).

### Diagnosis Procedure

INFOID:000000013717585

#### 1. CHECK COMMUNICATION SIGNAL

1. Turn ignition switch ON.
2. Check the signal between around view monitor control unit harness connector and ground.

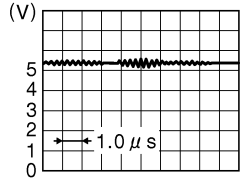
Terminals		Condition	Reference value
(+)	(-)		
Around view monitor control unit			
Connector	Terminal		
B51	55	Ground "CAMERA" switch is ON or shift position is "R".	 <p>(V)</p> <p>5 4 3 2 1 0</p> <p>1.0 μs</p> <p>JSNIA0836GB</p>

Is the inspection result normal?

YES >> Replace around view monitor control unit. Refer to [AV-647. "Removal and Installation"](#).

NO >> GO TO 2.

#### 2. CHECK CONTINUITY COMMUNICATION SIGNAL CIRCUIT FOR OPEN

1. Turn ignition switch OFF.
2. Disconnect around view monitor control unit harness connector and door mirror (driver side) harness connector.

## SIDE CAMERA LH COMMUNICATION SIGNAL CIRCUIT

< DTC/CIRCUIT DIAGNOSIS >

[AROUND VIEW MONITOR SYSTEM]

3. Check the continuity between around view monitor control unit harness connector and door mirror (driver side) harness connector.

Around view monitor control unit		Door mirror (driver side)		Continuity
Connector	Terminal	Connector	Terminal	
B51	55	D62	11	Existed

Is the inspection result normal?

YES >> GO TO 3.

NO >> Repair or replace malfunctioning parts.

### 3.CHECK CONTINUITY COMMUNICATION SIGNAL CIRCUIT FOR SHORT

Check the continuity between around view monitor control unit harness connector and ground.

Around view monitor control unit		Ground	Continuity
Connector	Terminal		
B51	55		Not existed

Is the inspection result normal?

YES >> Replace side camera LH. Refer to [AV-650. "Removal and Installation"](#).

NO >> Repair or replace malfunctioning parts.

A  
B  
C  
D  
E  
F  
G  
H  
I  
J  
K  
L  
M  
O  
P

AV

# SIDE CAMERA RH COMMUNICATION SIGNAL CIRCUIT

< DTC/CIRCUIT DIAGNOSIS >

[AROUND VIEW MONITOR SYSTEM]

## SIDE CAMERA RH COMMUNICATION SIGNAL CIRCUIT

### Description

INFOID:000000013717586

- Around view monitor control unit supplies to the front camera, rear camera and side camera. And then it superimpose the images from each camera and outputs then to the front display unit.
- Superimpose the guiding lines, predicted course line and sonar indicator to the camera image that outputs to the front display unit.
- Around view monitor control unit performs the reception/transmission of communication signal with each camera.

### Component Function Check

INFOID:000000013717587

#### 1. CHECK SIDE CAMERA RH COMMUNICATION STATUS

##### Ⓢ WITH CONSULT

1. Turn ignition switch ON.
2. Select "PA-SIDE CAMERA COMM STATUS" in "DATA MONITOR" mode of "AVM" using CONSULT.
3. Check "PA-SIDE CAMERA COMM STATUS" indication as per the following condition.

Monitor item	Condition	Indication
PA-SIDE CAMERA COMM STATUS	Side camera RH image is displayed	OK

##### NOTE:

Refer to [AV-467. "System Description"](#) for around view monitor operation.

Is the inspection result normal?

YES >> INSPECTION END

NO >> Proceed to [AV-638. "Diagnosis Procedure"](#).

### Diagnosis Procedure

INFOID:000000013717588

#### 1. CHECK COMMUNICATION SIGNAL

1. Connect around view monitor control unit connector and door mirror (passenger side) connector.
2. Turn ignition switch ON.
3. Check the signal between around view monitor control unit harness connector and ground.

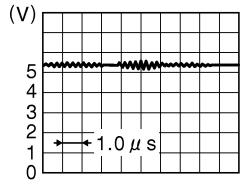
Terminals		Condition	Reference value
(+)	(-)		
Around view monitor control unit			
Connector	Terminal		
B51	61	Ground "CAMERA" switch is ON or shift position is "R".	 <p>(V)</p> <p>5 4 3 2 1 0</p> <p>1.0 μs</p> <p>JSNIA0836GB</p>

Is the inspection result normal?

YES >> Replace around view monitor control unit. Refer to [AV-647. "Removal and Installation"](#).

NO >> GO TO 2.

#### 2. CHECK CONTINUITY COMMUNICATION SIGNAL CIRCUIT

1. Turn ignition switch OFF.
2. Disconnect around view monitor control unit harness connector and door mirror (passenger side) harness connector.

# SIDE CAMERA RH COMMUNICATION SIGNAL CIRCUIT

[AROUND VIEW MONITOR SYSTEM]

< DTC/CIRCUIT DIAGNOSIS >

3. Check the continuity between around view monitor control unit harness connector and door mirror (passenger side) harness connector.

Around view monitor control unit		Door mirror (passenger side)		Continuity
Connector	Terminal	Connector	Terminal	
B51	61	D65	11	Existed

Is the inspection result normal?

YES >> GO TO 3.

NO >> Repair or replace malfunctioning parts.

## 3.CHECK CONTINUITY COMMUNICATION SIGNAL CIRCUIT

Check the continuity between around view monitor control unit harness connector and ground.

Around view monitor control unit		Ground	Continuity
Connector	Terminal		
B51	61		Not existed

Is the inspection result normal?

YES >> Replace side camera RH. Refer to [AV-650. "Removal and Installation"](#).

NO >> Repair or replace malfunctioning parts.

A  
B  
C  
D  
E  
F  
G  
H  
I  
J  
K  
L  
M  
O  
P

AV

# REAR CAMERA COMMUNICATION SIGNAL CIRCUIT

< DTC/CIRCUIT DIAGNOSIS >

[AROUND VIEW MONITOR SYSTEM]

## REAR CAMERA COMMUNICATION SIGNAL CIRCUIT

### Description

INFOID:000000013717589

- Around view monitor control unit supplies to the front camera, rear camera and side camera. And then it superimpose the images from each camera and outputs then to the display control unit.
- Superimpose the guiding lines, predicted course line and sonar indicator to the camera image that outputs to the display control unit.
- Around view monitor control unit performs the reception/transmission of communication signal with each camera.

### Component Function Check

INFOID:000000013717590

#### 1. CHECK REAR CAMERA COMMUNICATION STATUS

##### Ⓟ WITH CONSULT

1. Turn ignition switch ON.
2. Select "R-CAMERA COMM STATUS" in "DATA MONITOR" mode of "AVM" using CONSULT.
3. Check "R-CAMERA COMM STATUS" indication as per the following condition.

Monitor item	Condition	Indication
R-CAMERA COMM STATUS	Rear camera image is displayed	OK

##### NOTE:

Refer to [AV-467. "System Description"](#) for around view monitor operation.

Is the inspection result normal?

YES >> INSPECTION END

NO >> Proceed to [AV-640. "Diagnosis Procedure"](#).

### Diagnosis Procedure

INFOID:000000013717591

#### 1. CHECK COMMUNICATION SIGNAL

1. Turn ignition switch ON.
2. Check the signal between around view monitor control unit harness connector and ground.

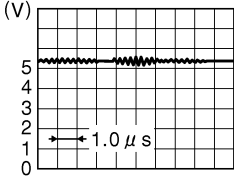
Terminals		(-)	Condition	Reference value
(+)				
Connector	Terminal			
B51	49	Ground	"CAMERA" switch is ON or shift position is "R".	 <p>(V)</p> <p>5 4 3 2 1 0</p> <p>← 1.0 μs</p> <p>JSNIA0836GB</p>

Is the inspection result normal?

YES >> Replace around view monitor control unit. Refer to [AV-647. "Removal and Installation"](#).

NO >> GO TO 2.

#### 2. CHECK CONTINUITY COMMUNICATION SIGNAL CIRCUIT FOR OPEN

1. Turn ignition switch OFF.
2. Disconnect around view monitor control unit harness connector and rear camera harness connector.
3. Check continuity between around view monitor control unit harness connector and rear camera harness connector.

# REAR CAMERA COMMUNICATION SIGNAL CIRCUIT

< DTC/CIRCUIT DIAGNOSIS >

[AROUND VIEW MONITOR SYSTEM]

Around view monitor control unit		Rear camera		Continuity
Connector	Terminal	Connector	Terminal	
B51	49	T50	4	Existed

Is the inspection result normal?

YES >> GO TO 3.

NO >> Repair or replace malfunctioning parts.

## 3. CHECK CONTINUITY COMMUNICATION SIGNAL CIRCUIT FOR SHORT

Check continuity between around view monitor control unit harness connector and ground.

Around view monitor control unit		Ground	Continuity
Connector	Terminal		
B51	49		Not existed

Is inspection result normal?

YES >> Replace rear camera. Refer to [AV-651, "Removal and Installation"](#).

NO >> Repair or replace malfunctioning parts.

A  
B  
C  
D  
E  
F  
G  
H  
I  
J  
K  
L  
M  
O  
P

AV

# REVERSE SIGNAL CIRCUIT

< DTC/CIRCUIT DIAGNOSIS >

[AROUND VIEW MONITOR SYSTEM]

## REVERSE SIGNAL CIRCUIT

### Component Function Check

INFOID:000000013717592

#### 1. CHECK REVERSE SIGNAL

④ With CONSULT

1. Turn ignition ON.
2. Select "REVERSE SIGNAL" in "DATA MONITOR" mode of "AVM" using CONSULT.
3. Check "REVERSE SIGNAL" indication as per the following condition.

Monitor item	Condition		Indication
REVERSE SIGNAL	Selector lever position	R position	On
		Other than R position	Off

Is the inspection result normal?

YES >> INSPECTION END

NO >> Proceed to [AV-642, "Diagnosis Procedure"](#).

### Diagnosis Procedure

INFOID:000000013717593

#### 1. CHECK REVERSE RANGE SIGNAL

1. Turn ignition switch ON.
2. Check the voltage between around view monitor control unit harness connector and ground as per the following condition.

Terminals		Condition	Voltage (Approx.)
(+)	(-)		
Connector	Terminal		
B50	25	Shift the selector lever to R position.	12.0 V
		Shift the selector lever other than R position.	0 V

Is the inspection result normal?

YES >> Replace around view monitor control unit. Refer to [AV-647, "Removal and Installation"](#).

NO >> GO TO 2.

#### 2. CHECK REVERSE SIGNAL CIRCUIT

1. Turn ignition switch OFF.
2. Disconnect around view monitor control unit harness connector.
3. Remove back-up lamp relay.
4. Check the continuity between around view monitor harness connector and back-up lamp relay harness connector.

Around view monitor		Back-up lamp relay		Continuity
Connector	Terminal	Connector	Terminal	
B50	25	M97	5	Existed

Is the inspection result normal?

YES >> GO TO 3.

NO >> Repair or replace malfunctioning parts.

#### 3. CHECK BACK-UP LAMP POWER SUPPLY

1. Turn ignition switch ON.

# REVERSE SIGNAL CIRCUIT

[AROUND VIEW MONITOR SYSTEM]

< DTC/CIRCUIT DIAGNOSIS >

- Check the voltage between back-up lamp relay harness connector and ground.

Terminals		Voltage (Approx.)
(+)		
Back-up lamp relay		
Connector	Terminal	Ground
M97	1	
	3	Battery voltage

Is the inspection result normal?

- YES >> GO TO 4.  
 NO >> Check ignition power supply circuit.

## 4.CHECK BACK-UP LAMP RELAY

- Turn ignition switch OFF.
- Check the back-up lamp relay. Refer to [AV-643, "Component Inspection"](#).

Is the inspection result normal?

- YES-1 >> VR30DDTT: Perform "Self Diagnostic Result" in "TRANSMISSION". Refer to [TM-86, "2.0L TURBO GASOLINE ENGINE : CONSULT Function"](#).  
 YES-2 >> 2.0L gasoline engine: Perform "Self Diagnostic Result" in "ENGINE". Refer to [EC4-100, "CONSULT Function"](#).  
 NO >> Replace back-up lamp relay.

## Component Inspection

INFOID:000000013717594

### 1.CHECK BACK-UP LAMP RELAY

- Turn ignition switch OFF.
- Remove back-up lamp relay.
- Check the continuity between back-up lamp relay terminals as per the following condition.

Back-up lamp relay		Condition	Continuity
Terminal			
3	5	12 V direct current supply between terminals 1 and 2	Existed
		No current supply	Not existed

Is the inspection result normal?

- YES >> INSPECTION END  
 NO >> Replace back-up lamp relay.

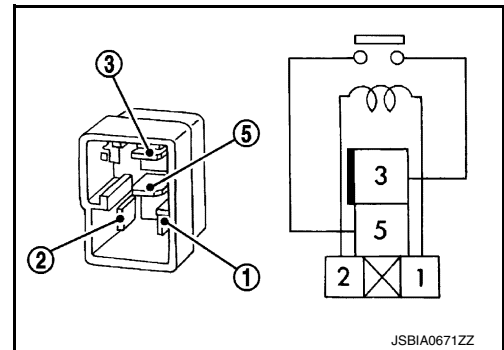

JSBIA0671ZZ

A  
B  
C  
D  
E  
F  
G  
H  
I  
J  
K  
L  
M  
O  
P

AV

# AROUND VIEW MONITOR SYSTEM

< SYMPTOM DIAGNOSIS >

[AROUND VIEW MONITOR SYSTEM]

## SYMPTOM DIAGNOSIS

### AROUND VIEW MONITOR SYSTEM

#### Symptom Table

INFOID:000000013717595

#### AROUND VIEW MONITOR SYSTEM

Symptoms	Check items		Probable malfunction location
Screen is not switched to camera image, when camera switch is pressed and when shift position is shifted to the reverse position.	“AVM” is not displayed on the system selection screen of CONSULT.		Around view monitor control unit power supply circuit <ul style="list-style-type: none"> <li>• BAT power supply circuit</li> <li>• Ignition power supply circuit</li> <li>• ACC power supply circuit</li> </ul>
	Check that the following data monitor items operate normally using CONSULT <ul style="list-style-type: none"> <li>• Camera switch signal</li> <li>• Reverse signal</li> </ul>	Camera switch signal and reverse signal are normal	Around view monitor control unit
		Camera switch signal or reverse signal is not normal	AV communication circuit
Screen is switched when pressing camera switch or shifting selector lever to the reverse position, however, all views are not displayed.	Only superimposing is displayed (only images that AV control unit plots are displayed).		Camera image signal circuit Refer to <a href="#">AV-629, "Diagnosis Procedure"</a> .
	Superimposing is not displayed.		Display control unit Refer to <a href="#">AV-102, "CONSULT Function"</a>
The screen is not switched to the rear view image even if the selector is shifted to the reverse position.	The front view is displayed normally.		Reverse signal circuit. Refer to <a href="#">AV-642, "Diagnosis Procedure"</a> .
<ul style="list-style-type: none"> <li>• Front view screen is not displayed.</li> <li>• Front of top view screen is displayed.</li> </ul>	Check the following data monitor items using CONSULT. <ul style="list-style-type: none"> <li>• Front camera image signal</li> <li>• Front view camera communication status</li> <li>• Front camera communication line</li> </ul>	<ul style="list-style-type: none"> <li>• Image signal: NG</li> <li>• Communication status: NG</li> <li>• Communication line: NG</li> </ul>	Front camera power supply circuit and image signal circuit Refer to <a href="#">AV-613, "Diagnosis Procedure"</a> .
		<ul style="list-style-type: none"> <li>• Image signal: OK</li> <li>• Communication status: NG</li> <li>• Communication line: NG</li> </ul>	Front camera communication circuit Refer to <a href="#">AV-634, "Diagnosis Procedure"</a> .
<ul style="list-style-type: none"> <li>• The rear view screen is not displayed.</li> <li>• Rear of top view screen is not displayed.</li> </ul>	Check the following data monitor items using CONSULT. <ul style="list-style-type: none"> <li>• Rear camera image signal</li> <li>• Rear camera communication status</li> <li>• Rear camera communication line</li> </ul>	<ul style="list-style-type: none"> <li>• Image signal: NG</li> <li>• Communication status: NG</li> <li>• Communication line: NG</li> </ul>	Rear camera power supply circuit and image signal circuit Refer to <a href="#">AV-607, "Diagnosis Procedure"</a> .
		<ul style="list-style-type: none"> <li>• Image signal: OK</li> <li>• Communication status: NG</li> <li>• Communication line: NG</li> </ul>	Rear camera communication signal circuit Refer to <a href="#">AV-640, "Diagnosis Procedure"</a> .
<ul style="list-style-type: none"> <li>• The side view screen is not displayed.</li> <li>• Left side of top view screen is not displayed.</li> </ul>	Check the following data monitor items using CONSULT. <ul style="list-style-type: none"> <li>• Side camera LH image signal</li> <li>• Side camera LH communication status</li> <li>• Side camera LH communication line</li> </ul>	<ul style="list-style-type: none"> <li>• Image signal: NG</li> <li>• Communication status: NG</li> <li>• Communication line: NG</li> </ul>	Side camera LH power supply circuit and image signal circuit Refer to <a href="#">AV-616, "Diagnosis Procedure"</a> .
		<ul style="list-style-type: none"> <li>• Image signal: OK</li> <li>• Communication status: NG</li> <li>• Communication line: NG</li> </ul>	Side camera LH communication circuit Refer to <a href="#">AV-636, "Diagnosis Procedure"</a> .

# AROUND VIEW MONITOR SYSTEM

< SYMPTOM DIAGNOSIS >

[AROUND VIEW MONITOR SYSTEM]

Symptoms	Check items	Probable malfunction location
Right side of top view image is not displayed.	Check the following data monitor items using CONSULT. • Side camera RH image signal • Side camera RH communication status • Side camera RH communication line	<ul style="list-style-type: none"> <li>• Image signal: NG</li> <li>• Communication status: NG</li> <li>• Communication line: NG</li> </ul> Side camera RH power supply circuit and image signal circuit. Refer to <a href="#">AV-610, "Diagnosis Procedure"</a> .
		<ul style="list-style-type: none"> <li>• Image signal: OK</li> <li>• Communication status: NG</li> <li>• Communication line: NG</li> </ul> Side camera RH communication circuit. Refer to <a href="#">AV-638, "Diagnosis Procedure"</a> .

## CAMERA ASSISTANCE SONAR

Symptoms	Check items	Possible malfunction location/Action to take
Sonar indicator is not displayed normally (always displayed in red).	Only 1 indicator is not displayed normally (always displayed in red).	<ul style="list-style-type: none"> <li>• Corner sensor or center sensor of applicable position is not normal.</li> <li>• Corner sensor or center sensor harness circuit of applicable position</li> </ul> Perform self-diagnosis of "SONAR" using CONSULT. Refer to <a href="#">AV-491, "CONSULT Function"</a> .
	Display of all 8 indicators is not normal (always displayed in red).	<ul style="list-style-type: none"> <li>• Corner sensor or center sensor ground circuit</li> <li>• Sonar control unit power supply and ground circuit. Refer to <a href="#">AV-628, "SONAR CONTROL UNIT : Diagnosis Procedure"</a>.</li> <li>• AV communication circuit.</li> </ul> Perform self-diagnosis of "MULTI AV" using CONSULT. Refer to <a href="#">AV-102, "CONSULT Function"</a> .

A  
B  
C  
D  
E  
F  
G  
H  
I  
J  
K  
L  
M

AV

O  
P

# NORMAL OPERATING CONDITION

< SYMPTOM DIAGNOSIS >

[AROUND VIEW MONITOR SYSTEM]

## NORMAL OPERATING CONDITION

### Description

INFOID:000000013717596

**NOTE:**

For Navigation system operation information, refer to Navigation system Owner's Manual.

### BASIC OPERATIONS

Symptom	Possible cause	Possible solution
No image is displayed.	The brightness is at the lowest setting.	Adjust the brightness of the display.
	The systems in the video mode.	Press "DISC-AUX" to change the mode.
	The display is turned off.	Press "☀/☾" to turn on the display.
	The interior of the vehicle becomes the a little less than 80°C (176°F) or high temperature, and the protection of the display acts, and a display is turned off.	Wait until the interior of the vehicle has cooled down.
Screen not clear.	Contrast setting is not appropriate.	Adjust the contrast of the display.
No voice guidance is available. Or The volume is too high or too low.	The volume is not set correctly, or it is turned off.	Adjust the volume of voice guidance.
	Voice guidance is not provided for certain streets (roads displayed in gray).	This is not a malfunction.
No map is displayed on the screen.	A screen other than map screen is displayed.	Press "MAP".
The screen is too dim. The movement is slow.	The temperature in the interior of the vehicle is low.	Wait until the interior of the vehicle has warmed up.
Some pixels in the display are darker or brighter than others.	This condition is an inherent characteristic of liquid crystal displays.	This is not a malfunction.
Some menu items cannot be selected.	Some menu items become unavailable while the vehicle is driven.	Park the vehicle in a safe location, and then operate the navigation system.

**NOTE:**

Locations stored in the Address Book and other memory functions may be lost if the vehicle's battery is disconnected or becomes discharged. If this occurs, service the vehicle's battery as necessary and re-enter the information in the Address Book.

### RELATED TO SONAR

Symptom	Possible cause
Unstable object detection	<ul style="list-style-type: none"> <li>• The vehicle is on a rough surface, such as stone or gravel.</li> <li>• When used in poor weather conditions, such as heavy snow/rain or strong wind.</li> <li>• When subjected to an ultrasonic noise generated from exhaust muffler or brakes.</li> <li>• When left standing in the hot sun or in a cold climate.</li> <li>• When the surface of the sensor is frozen or covered with snow/dirt/moisture.</li> <li>• When a retrofitted xenon lamp, lighted license plate, or harness is close to the sensor body or sensor harness.</li> <li>• When subjected to loop coil noises generated from a vehicle detector placed at an intersection or coin parking area.</li> </ul>
Object undetectable	<ul style="list-style-type: none"> <li>• Air-containing objects, such as cloth, cotton, glass wool, dust, and snow.</li> <li>• Thin objects, such as rope, chain, and wire.</li> <li>• Smooth-faced objects placed in a slanting direction.</li> <li>• Fast-moving small animals.</li> <li>• A corner of an angular object.</li> </ul> <p><b>NOTE:</b> If the sensor detection part is scratched, obstacles cannot be detected.</p>

# AROUND VIEW MONITOR CONTROL UNIT

< REMOVAL AND INSTALLATION >

[AROUND VIEW MONITOR SYSTEM]

## REMOVAL AND INSTALLATION

### AROUND VIEW MONITOR CONTROL UNIT

#### Removal and Installation

INFOID:000000013717597

#### REMOVAL

##### CAUTION:

Before replacing around view monitor control unit, perform "Read/Write Configuration" to save or print current vehicle specification. For details, refer to [AV-561](#), "Description".

1. Remove the rear side finisher RH. Refer to [INT-23](#), "REAR SIDE FINISHER : Removal and Installation".
2. Remove the floor carpet assembly ① from pawls (A) and (B).

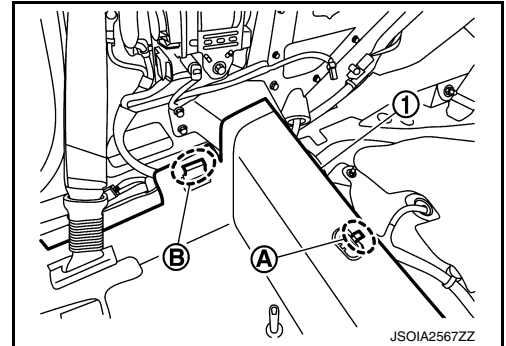

3. Remove bolts (A) and (B) and remove the rear floor gusset RH ①.

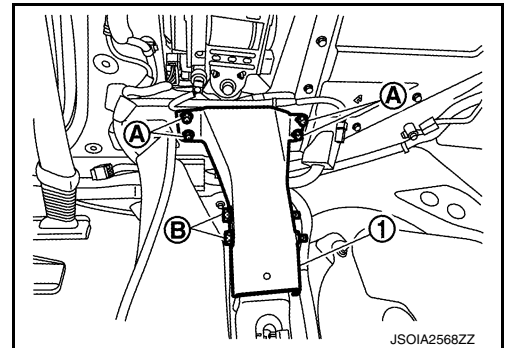

4. Remove the nut (A) and bolts (B) to remove the rear pillar inner reinforcement RH ①.

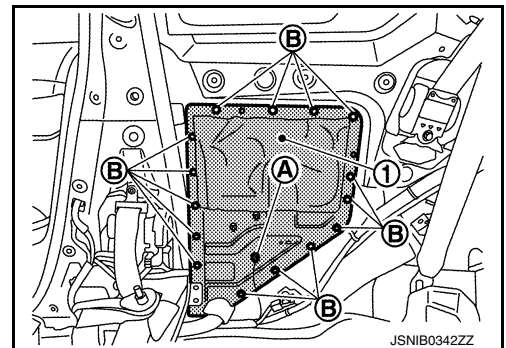

5. Disconnect the around view monitor control unit connectors (A).
6. Remove the screws (B) to remove the around view monitor control unit ①.

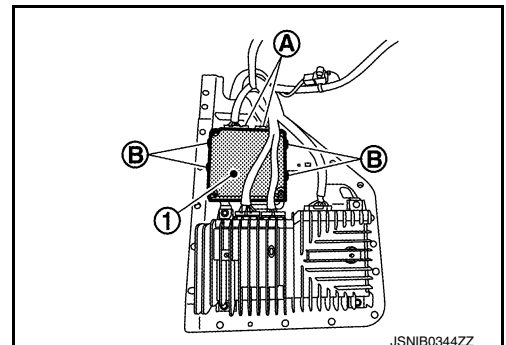

A  
B  
C  
D  
E  
F  
G  
H  
I  
J  
K  
L  
M  
AV  
O  
P

# AROUND VIEW MONITOR CONTROL UNIT

< REMOVAL AND INSTALLATION >

[AROUND VIEW MONITOR SYSTEM]

## INSTALLATION

1. Note the following, and install in the reverse order of removal.
  - Tighten the rear floor gusset RH ① bolts to the specified torque.

**Bolt (A) : 35 N·m (3.6 kg-m, 26 ft-lb)**

**Bolt (B) : 80 N·m (8.2 kg-m, 59 ft-lb)**

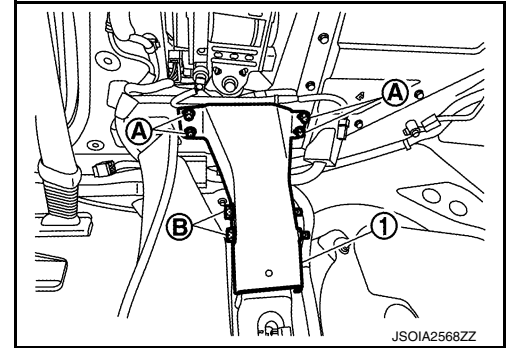

2. Perform camera image calibration. Refer to [AV-566. "Description"](#).
3. Perform predictive course line center position adjustment. Refer to [AV-565. "Description"](#).

### CAUTION:

- Be sure to perform “Read/Write Configuration” when replacing around view monitor control unit. For details, refer to [AV-561. "Description"](#).
- Perform the calibration and perform the writing to the around view monitor control unit when removing and replacing each camera, removing the camera mounting parts (front grille, door mirror, etc.) and replacing the around view monitor control unit.

# FRONT CAMERA

< REMOVAL AND INSTALLATION >

[AROUND VIEW MONITOR SYSTEM]

## FRONT CAMERA

### Removal and Installation

INFOID:000000013717598

#### REMOVAL

1. Remove front bumper fascia assembly. Refer to [EXT-23, "Removal and Installation"](#).
2. Remove screws (A) to remove front camera (1).

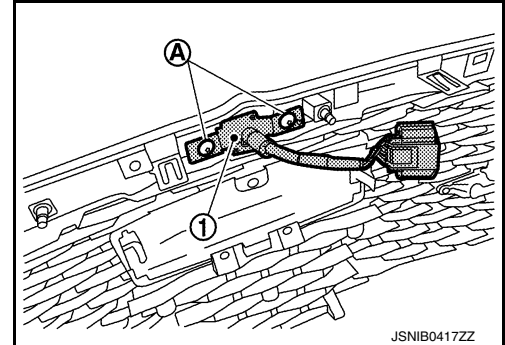

#### INSTALLATION

1. Install in the reverse order of removal.
2. Perform camera image calibration. Refer to [AV-566, "Description"](#).

#### **CAUTION:**

Perform the calibration and perform the writing to the around view monitor control unit when removing and replacing each camera, removing the camera mounting parts (front grille, door mirror, etc.) and replacing the around view monitor control unit.

A  
B  
C  
D  
E  
F  
G  
H  
I  
J  
K  
L  
M  
O  
P

AV

# SIDE CAMERA

< REMOVAL AND INSTALLATION >

[AROUND VIEW MONITOR SYSTEM]

## SIDE CAMERA

### Removal and Installation

INFOID:000000013717599

#### REMOVAL

1. Remove the side camera finisher. Refer to Refer to [MIR-54, "DOOR MIRROR ASSEMBLY : Disassembly and Assembly"](#) (WITH ADP), or [MIR-84, "DOOR MIRROR ASSEMBLY : Disassembly and Assembly"](#) (WITHOUT ADP).
2. Remove screws **A** to remove side camera **1**.

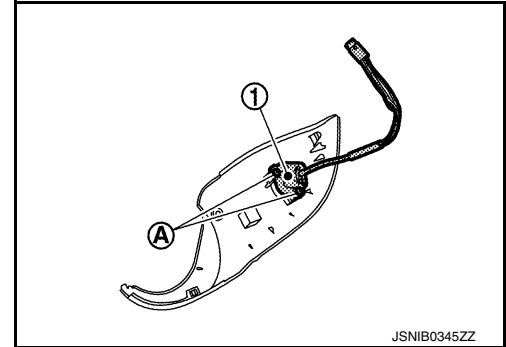

#### INSTALLATION

1. Install in the reverse order of removal.
2. Perform camera image calibration. Refer to [AV-566, "Description"](#).

**CAUTION:**

Perform the calibration and perform the writing to the around view monitor control unit when removing and replacing each camera, removing the camera mounting parts (front grille, door mirror, etc.) and replacing the around view monitor control unit.

# REAR CAMERA

< REMOVAL AND INSTALLATION >

[AROUND VIEW MONITOR SYSTEM]

## REAR CAMERA

### Removal and Installation

INFOID:000000013717600

#### REMOVAL

1. Remove the trunk lid trim. Refer to [INT-43, "Removal and Installation"](#).
2. Remove the rear camera mounting screws (A).
3. Disconnect the harness connector (B) to remove the rear camera ①.

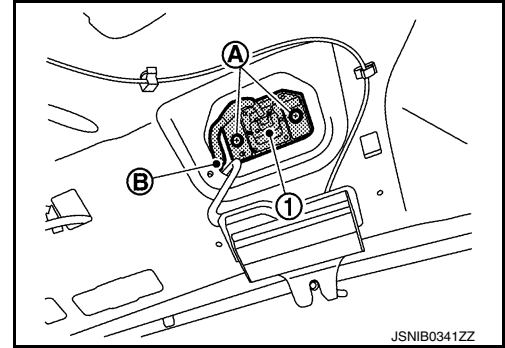

#### INSTALLATION

1. Install in the reverse order of removal.
2. Perform camera image calibration. Refer to [AV-566, "Description"](#).

**CAUTION:**

Perform the calibration and perform the writing to the around view monitor control unit when removing and replacing each camera, removing the camera mounting parts (front grille, door mirror, etc.) and replacing the around view monitor control unit.

A  
B  
C  
D  
E  
F  
G  
H  
I  
J  
K  
L  
M  
N  
O  
P

AV

# SONAR CONTROL UNIT

< REMOVAL AND INSTALLATION >

[AROUND VIEW MONITOR SYSTEM]

## SONAR CONTROL UNIT

### Removal and Installation

INFOID:000000013717601

#### REMOVAL

**CAUTION:**

Before replacing sonar control unit, perform “Read/Write Configuration” to save or print current vehicle specification. For details, refer to [AV-562, "Description"](#).

1. Remove the instrument lower panel RH. Refer to [IP-13, "Removal and Installation"](#).
2. Remove screws **A** to remove sonar control unit **1**.

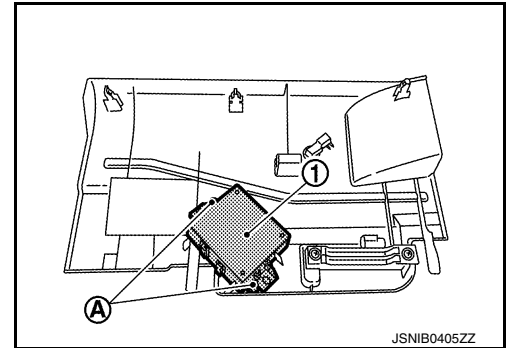

#### INSTALLATION

Install in the reverse order of removal.

**CAUTION:**

Be sure to perform “Read/Write Configuration” when replacing sonar control unit. For details, refer to [AV-562, "Description"](#).

# SONAR SENSOR

< REMOVAL AND INSTALLATION >

[AROUND VIEW MONITOR SYSTEM]

## SONAR SENSOR

### FRONT

#### FRONT : Exploded View

INFOID:000000013717602

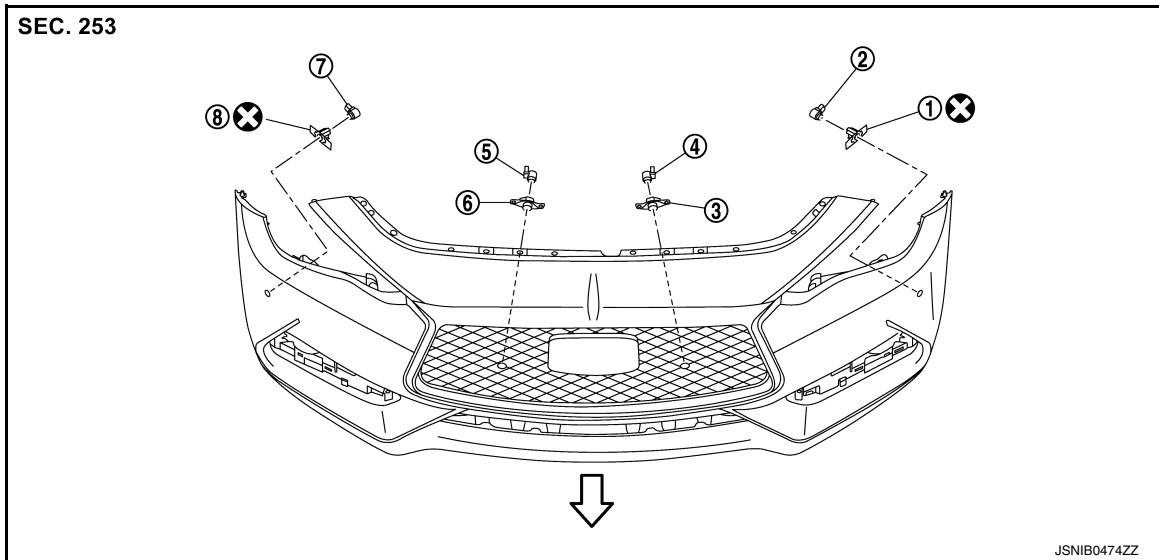

- |                                   |                                   |                                   |
|-----------------------------------|-----------------------------------|-----------------------------------|
| ① Corner sensor finisher front LH | ② Corner sensor front LH          | ③ Center sensor finisher front LH |
| ④ Center sensor front LH          | ⑤ Center sensor finisher front RH | ⑥ Center sensor finisher front RH |
| ⑦ Corner sensor front RH          | ⑧ Corner sensor finisher front RH |                                   |

⊗ : Always replace after every disassembly.

↶ : Vehicle front

#### FRONT : Removal and Installation

INFOID:000000013717603

#### REMOVAL

##### CENTER SENSOR

1. Remove front grille. Refer to [EXT-33, "Removal and Installation"](#).
2. Unhook the pawls to remove sonar sensor ①.

△ : Pawl

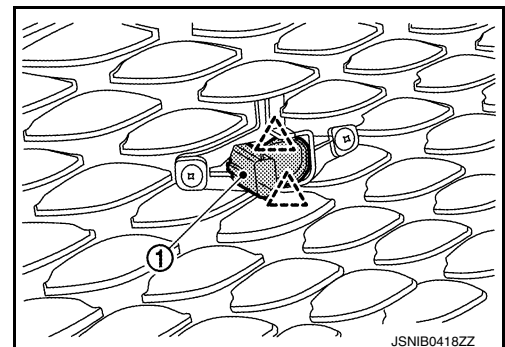

##### CORNER SENSOR

1. Remove front bumper fascia. Refer to [EXT-23, "Removal and Installation"](#).
2. Disconnect sonar sensor connector.

# SONAR SENSOR

## < REMOVAL AND INSTALLATION >

## [AROUND VIEW MONITOR SYSTEM]

- Unhook the pawls to remove sonar sensor ①.

 : Pawl

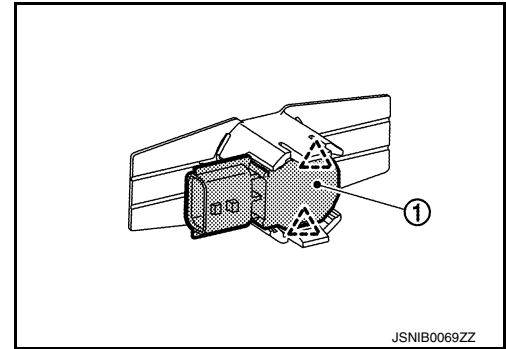

## INSTALLATION

### CENTER SENSOR

Install in the reverse order of removal.

### CORNER SENSOR

- Install sonar sensor to sensor holder.
- Apply primer to sensor mounting part ① of bumper.

#### **CAUTION:**

**Never apply two coats of primer. Applying two coats or more of primer results in excessively thick film and this may allow the sensor holder to come off from primer under exfoliation.**

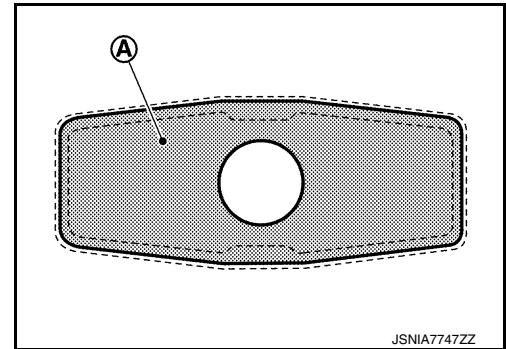

- Remove the film of double-sided tape, bend sensor holder in the direction shown by arrow so that double-sided tape ② does not contact bumper, and align portion ① of sonar sensor with the bumper hole.

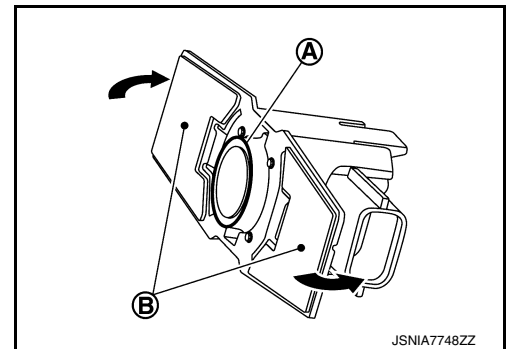

- Press portion ① of sensor holder to paste the sensor holder to bumper as shown in the figure.

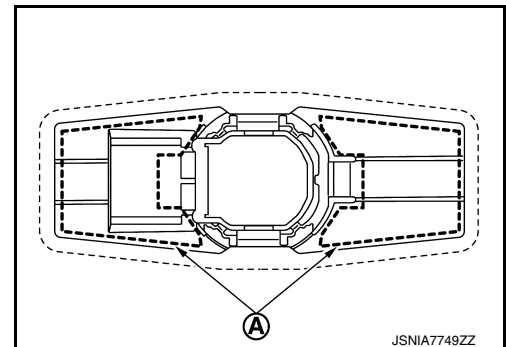

- Install connector to sonar sensor.
- Install front bumper fascia. Refer to [EXT-23, "Removal and Installation"](#).

#### **CAUTION:**

- Check sonar sensor packing for damage before installation.
- Check that the packing is properly installed to the sonar sensor.

# SONAR SENSOR

< REMOVAL AND INSTALLATION >

[AROUND VIEW MONITOR SYSTEM]

- Install it so that the connector of the sensor turns to the arrow direction of the figure.

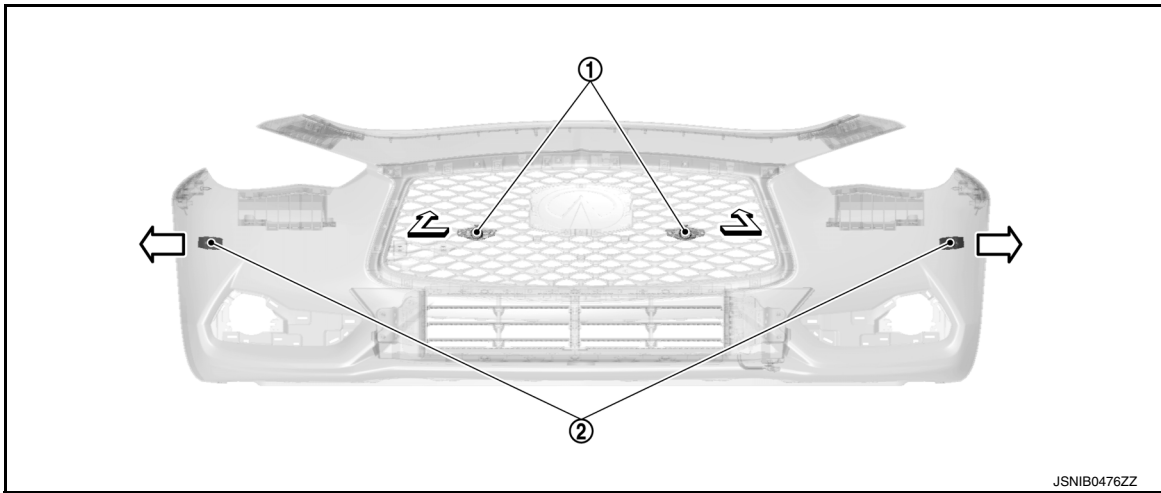

- ① Center sensor front
- ② Corner sensor front
- ↔ : Connector direction

## REAR

### REAR : Exploded View

INFOID:000000013717604

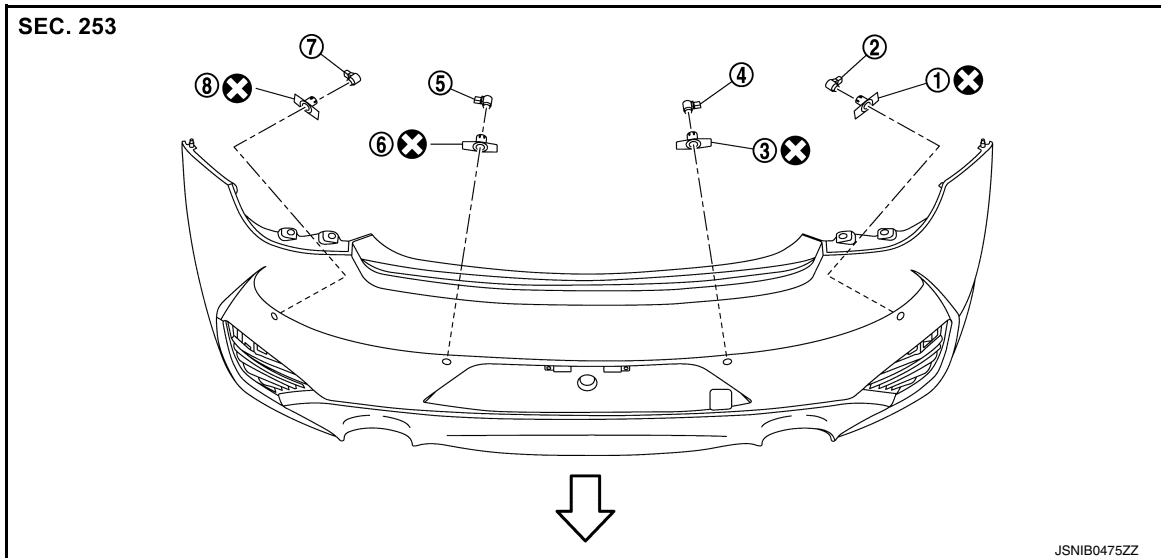

- ① Corner sensor finisher rear RH
  - ② Corner sensor rear RH
  - ③ Center sensor finisher rear RH
  - ④ Center sensor rear RH
  - ⑤ Center sensor rear LH
  - ⑥ Center sensor finisher rear LH
  - ⑦ Corner sensor rear LH
  - ⑧ Corner sensor finisher rear LH
- ⊗ : Always replace after every disassembly.  
 ↔ : Vehicle front

### REAR : Removal and Installation

INFOID:000000013717605

#### REMOVAL

1. Remove rear bumper fascia assembly. Refer to [EXT-28. "Removal and Installation"](#).
2. Disconnect sonar sensor connector.

A  
B  
C  
D  
E  
F  
G  
H  
I  
J  
K  
L  
M  
N  
O  
P

AV

# SONAR SENSOR

## < REMOVAL AND INSTALLATION >

## [AROUND VIEW MONITOR SYSTEM]

- Unhook the pawls to remove sonar sensor ①.

 : Pawl

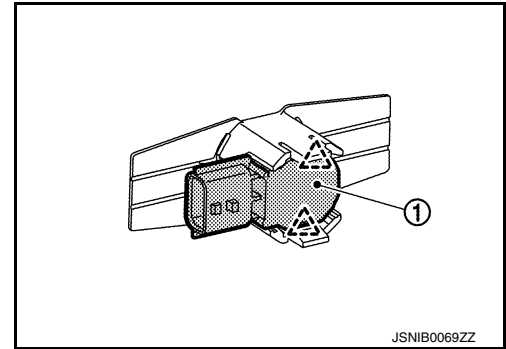

## INSTALLATION

- Install sonar sensor to sensor holder.
- Apply primer to sensor mounting part ① of bumper.

### CAUTION:

Never apply two coats of primer. Applying two coats or more of primer results in excessively thick film and this may allow the sensor holder to come off from primer under exfoliation.

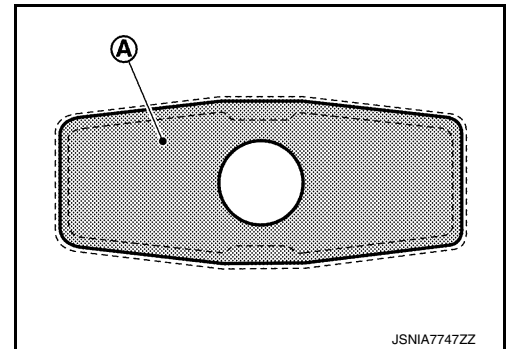

- Remove the film of double-sided tape, bend sensor holder in the direction shown by arrow so that double-sided tape ② does not contact bumper, and align portion ① of sonar sensor with the bumper hole.

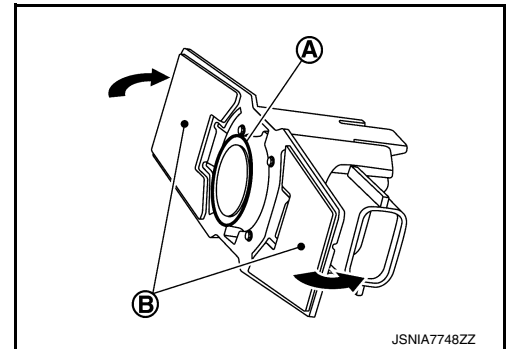

- Press portion ① of sensor holder to paste the sensor holder to bumper as shown in the figure.

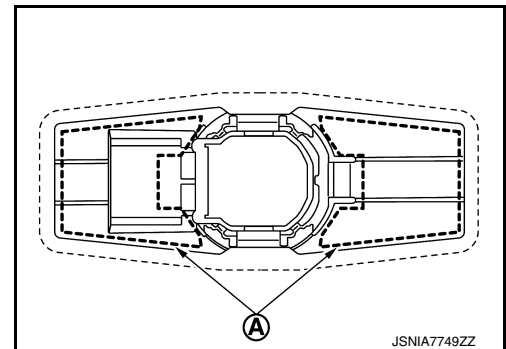

- Install connector to sonar sensor.
- Install rear bumper fascia assembly. Refer to [EXT-28. "Removal and Installation"](#).

### CAUTION:

- Check sonar sensor packing for damage before installation.
- Check that the packing is properly installed to the sonar sensor.
- Install it so that the connector of the sensor turns to the arrow direction of the figure.

# SONAR SENSOR

< REMOVAL AND INSTALLATION >

[AROUND VIEW MONITOR SYSTEM]

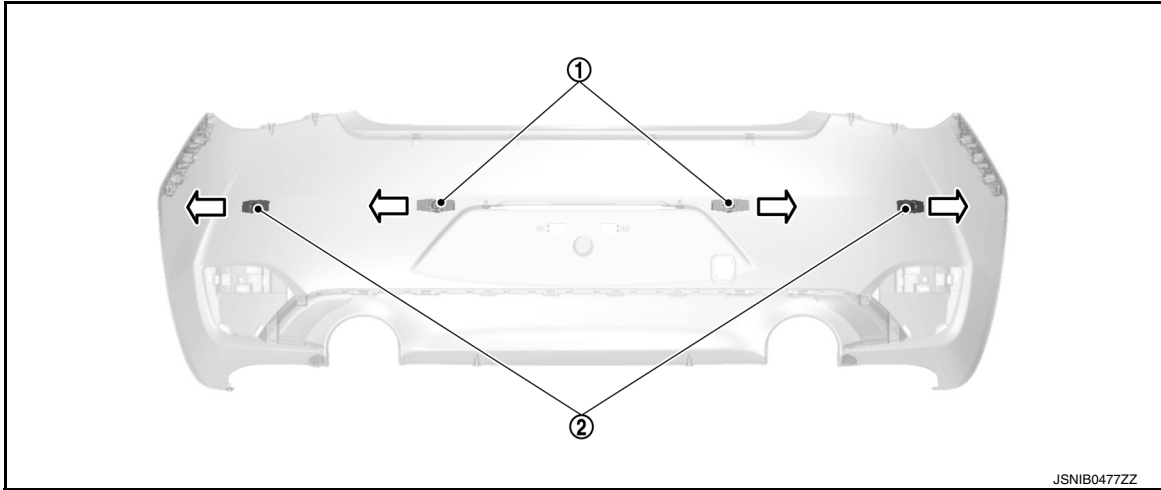

① Center sensor rear

② Corner sensor rear

⇐ : Connector direction

A

B

C

D

E

F

G

H

I

J

K

L

M

AV

O

P

# BUZZER

< REMOVAL AND INSTALLATION >

[AROUND VIEW MONITOR SYSTEM]

## BUZZER

### Removal and Installation

INFOID:000000013717606

#### REMOVAL

1. Remove instrument lower panel LH. Refer to [IP-13. "Removal and Installation"](#).
2. Remove the buzzer mounting nuts  $\textcircled{A}$  to remove the buzzer  $\textcircled{1}$ .

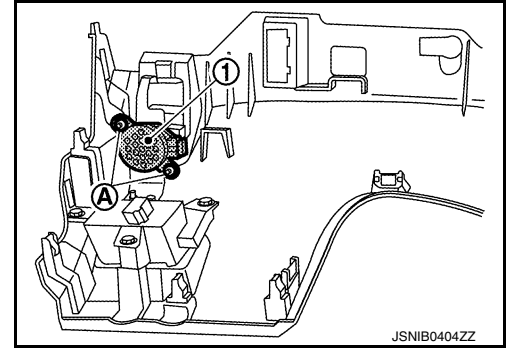

#### INSTALLATION

Install in the reverse order of removal.

# STEERING ANGLE SENSOR

< REMOVAL AND INSTALLATION >

[AROUND VIEW MONITOR SYSTEM]

## STEERING ANGLE SENSOR

### Removal and Installation

INFOID:000000013717607

#### REMOVAL

1. Remove the spiral cable. Refer to [SR-21, "Removal and Installation"](#).
2. Remove the steering angle sensor from spiral cable.

#### INSTALLATION

Install in the reverse order of removal.

A  
B  
C  
D  
E  
F  
G  
H  
I  
J  
K  
L  
M  
O  
P

AV

## PRECAUTION

### PRECAUTIONS

#### Precaution for Supplemental Restraint System (SRS) "AIR BAG" and "SEAT BELT PRE-TENSIONER"

INFOID:000000014286317

The Supplemental Restraint System such as "AIR BAG" and "SEAT BELT PRE-TENSIONER", used along with a front seat belt, helps to reduce the risk or severity of injury to the driver and front passenger for certain types of collision. This system includes seat belt switch inputs and dual stage front air bag modules. The SRS system uses the seat belt switches to determine the front air bag deployment, and may only deploy one front air bag, depending on the severity of a collision and whether the front occupants are belted or unbelted. Information necessary to service the system safely is included in the "SRS AIR BAG" and "SEAT BELT" of this Service Manual.

**WARNING:**

Always observe the following items for preventing accidental activation.

- To avoid rendering the SRS inoperative, which could increase the risk of personal injury or death in the event of a collision that would result in air bag inflation, it is recommended that all maintenance and repair be performed by an authorized NISSAN/INFINITI dealer.
- Improper repair, including incorrect removal and installation of the SRS, can lead to personal injury caused by unintentional activation of the system. For removal of Spiral Cable and Air Bag Module, see "SRS AIR BAG".
- Never use electrical test equipment on any circuit related to the SRS unless instructed to in this Service Manual. SRS wiring harnesses can be identified by yellow and/or orange harnesses or harness connectors.

#### PRECAUTIONS WHEN USING POWER TOOLS (AIR OR ELECTRIC) AND HAMMERS

**WARNING:**

Always observe the following items for preventing accidental activation.

- When working near the Air Bag Diagnosis Sensor Unit or other Air Bag System sensors with the ignition ON or engine running, never use air or electric power tools or strike near the sensor(s) with a hammer. Heavy vibration could activate the sensor(s) and deploy the air bag(s), possibly causing serious injury.
- When using air or electric power tools or hammers, always switch the ignition OFF, disconnect the battery or batteries, and wait at least 3 minutes before performing any service.

#### Precaution for Battery Service

INFOID:000000014286318

Before disconnecting the battery, lower both the driver and passenger windows. This will prevent any interference between the window edge and the vehicle when the door is opened/closed. During normal operation, the window slightly raises and lowers automatically to prevent any window to vehicle interference. The automatic window function will not work with the battery disconnected.

#### Precautions for Removing Battery Terminal

INFOID:000000014286319

When disconnecting the battery terminal, pay attention to the following.

- Always use a 12V battery as power source.
- Never disconnect battery terminal while engine is running.
- When removing the 12V battery terminal, turn OFF the ignition switch and wait at least 30 seconds.
- For vehicles with the engine listed below, remove the battery terminal after a lapse of the specified time:

BR08DE	: 4 minutes	YD25DDTi	: 2 minutes
D4D engine	: 20 minutes	YS23DDT	: 4 minutes
HRA2DDT	: 12 minutes	YS23DDTT	: 4 minutes
K9K engine	: 4 minutes	ZD30DDTi	: 60 seconds
M9R engine	: 4 minutes	ZD30DDTT	: 60 seconds
R9M engine	: 4 minutes		
V9X engine	: 4 minutes		

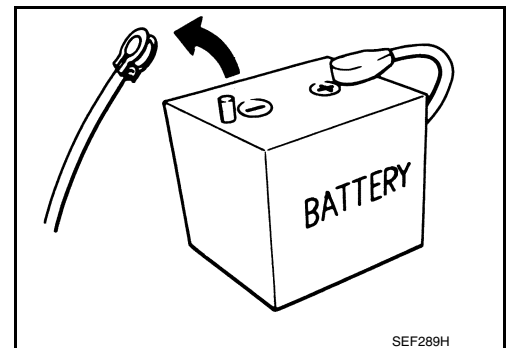

# PRECAUTIONS

## [REAR VIEW MONITOR SYSTEM]

### < PRECAUTION >

#### NOTE:

ECU may be active for several tens of seconds after the ignition switch is turned OFF. If the battery terminal is removed before ECU stops, then a DTC detection error or ECU data corruption may occur.

- After high-load driving, if the vehicle is equipped with the V9X engine, turn the ignition switch OFF and wait for at least 15 minutes to remove the battery terminal.

#### NOTE:

- Turbocharger cooling pump may operate in a few minutes after the ignition switch is turned OFF.
- Example of high-load driving
  - Driving for 30 minutes or more at 140 km/h (86 MPH) or more.
  - Driving for 30 minutes or more on a steep slope.
- For vehicles with the 2-batteries, be sure to connect the main battery and the sub battery before turning ON the ignition switch.

#### NOTE:

If the ignition switch is turned ON with any one of the terminals of main battery and sub battery disconnected, then DTC may be detected.

- After installing the 12V battery, always check "Self Diagnosis Result" of all ECUs and erase DTC.

#### NOTE:

The removal of 12V battery may cause a DTC detection error.

### Precaution for Trouble Diagnosis

INFOID:000000013717610

#### AV COMMUNICATION SYSTEM

- Do not apply voltage of 7.0 V or higher to the measurement terminals.
- Use the tester with its open terminal voltage being 7.0 V or less.
- Be sure to turn ignition switch OFF and disconnect the battery cable from the negative terminal before checking the circuit.

### Precaution for Harness Repair

INFOID:000000013717611

#### AV COMMUNICATION SYSTEM

- Solder the repaired parts, and wrap with tape. [Frays of twisted line must be within 110 mm (4.33 in).]

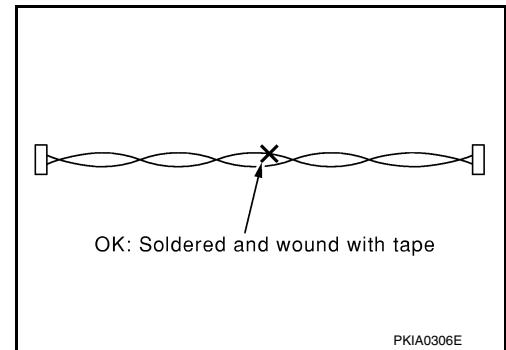

- Do not perform bypass wire connections for the repair parts. (The spliced wire will become separated and the characteristics of twisted line will be lost.)

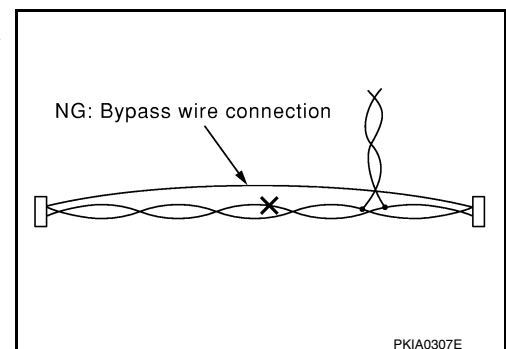

# PREPARATION

< PREPARATION >

[REAR VIEW MONITOR SYSTEM]

## PREPARATION

### PREPARATION

#### Commercial Service Tools

INFOID:000000013717612

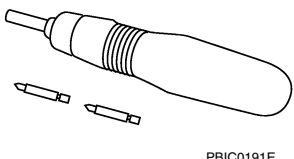
Tool	Description
<p data-bbox="162 514 267 546">Power tool</p>  <p data-bbox="820 619 901 651">PBIC0191E</p>	<p data-bbox="1006 514 1193 546">Loosening screws</p>

< SYSTEM DESCRIPTION >

SYSTEM DESCRIPTION

COMPONENT PARTS

Component Parts Location

INFOID:000000013717613

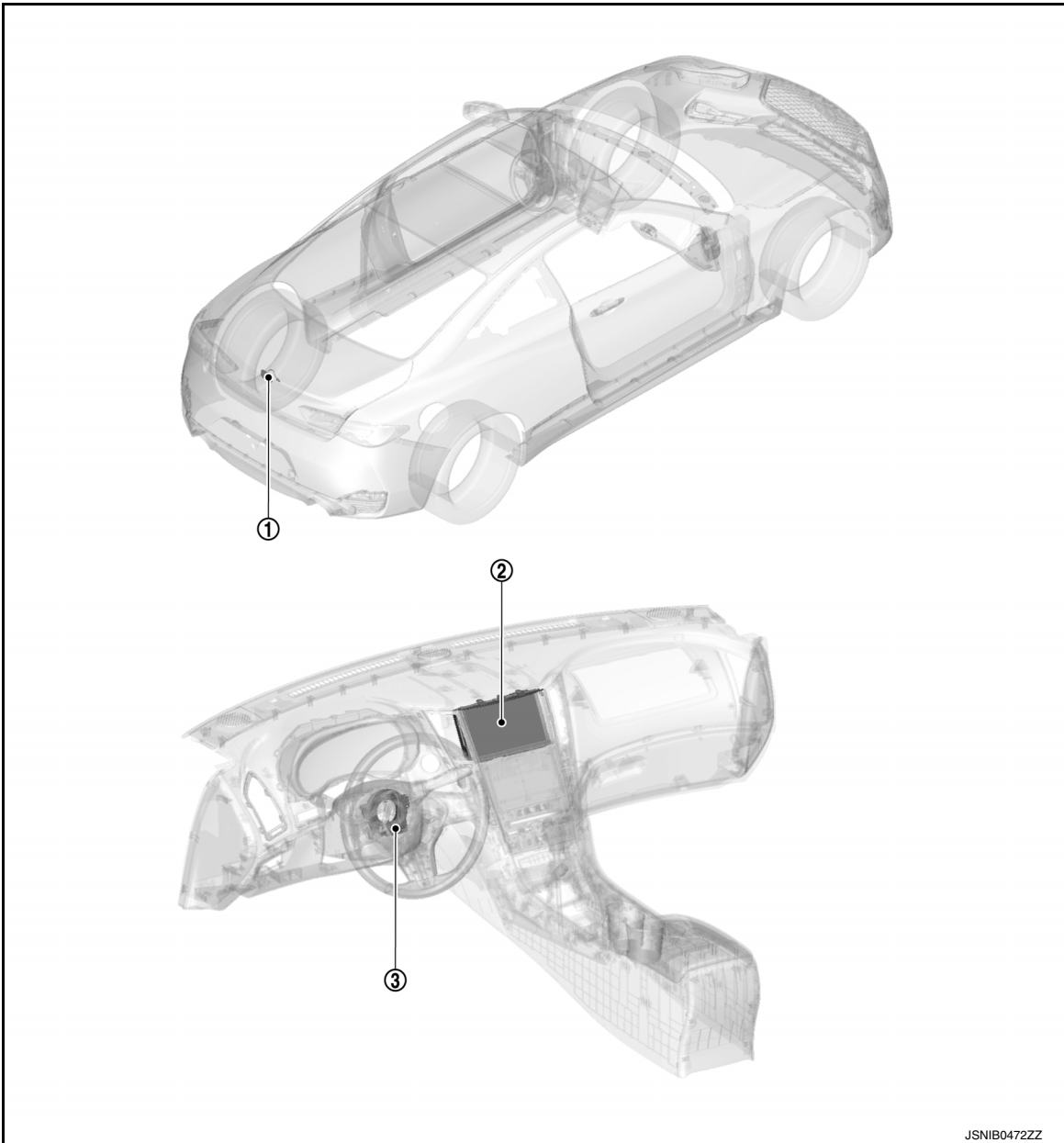

JSNIB0472ZZ

No.	Component	Function
①	Rear view camera	Refer to <a href="#">AV-664, "Rear View Camera"</a> .
②	Display control unit	Refer to <a href="#">AV-663, "Display Control Unit"</a> .
③	Steering angle sensor	Refer to <a href="#">AV-664, "Steering Angle Sensor"</a> .

Display Control Unit

INFOID:000000013717614

DESCRIPTION

A  
B  
C  
D  
E  
F  
G  
H  
I  
J  
K  
L  
M  
O  
P

AV

# COMPONENT PARTS

## < SYSTEM DESCRIPTION >

## [REAR VIEW MONITOR SYSTEM]

- Display control unit is located in the center of the instrument panel assembly.
- Display control unit integrates the following functions, and controls the rear view monitor system.

Unit equipped
Display
Camera controller

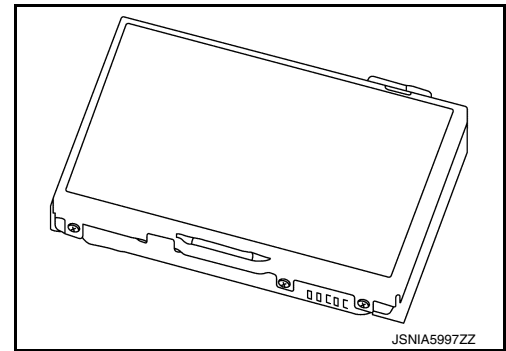

## SPECIFICATION

Camera controller	Guideline display function	Vehicle width guide lines
	Steering signal input method	Predictive course lines
		CAN communication

## Rear View Camera

INFOID:000000013717615

- The rear view camera is installed at the center of the trunk lid.
- Super-small CMOS camera (color) using CMOS\* for the image pickup element is adopted.
- With the mirror processing function, a mirror image is sent as if it is viewed by a rear view mirror.
- Power for the camera is supplied from the display control unit, and the image at the rear of the vehicle is sent to the display control unit.

### NOTE:

\*: "CMOS" is abbreviation of Complementary Metal Oxide Semiconductor, and features low power consumption and high speed reading rate of electric charge.

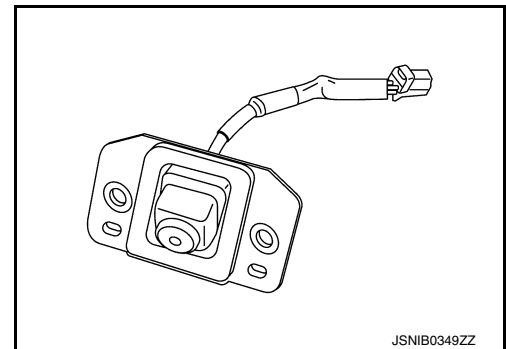

## Specification

Image pickup element	1/4-inch CMOS image sensor
Effective number of pixels	Approx. 300,000 pixels (632 × 480)
Minimum brightness	1 lx
Angle of view	Horizontal view angle: 130.3° Vertical view angle: 91.2°
Image	With mirror processing function

## Steering Angle Sensor

INFOID:000000013717616

- Steering angle sensor is installed to the spiral cable.
- Steering angle sends the steering signal necessary for predictive course line of the rear view monitor to the display control unit via CAN communication.

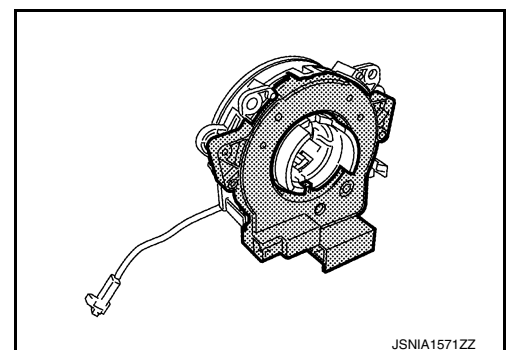

# REAR VIEW MONITOR SYSTEM

< SYSTEM DESCRIPTION >

[REAR VIEW MONITOR SYSTEM]

## REAR VIEW MONITOR SYSTEM

### System Description

INFOID:000000013717617

### SYSTEM DIAGRAM

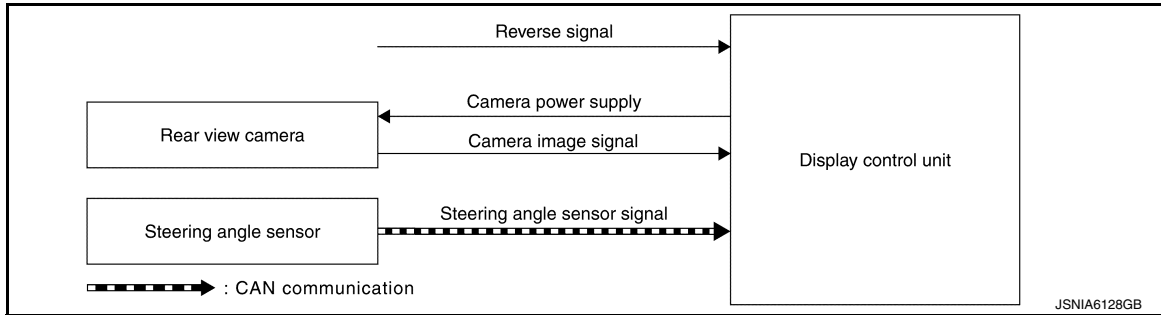

### Display Control Unit Input Signal (CAN Communication)

Transmit unit	Signal name
Steering angle sensor	Steering angle signal

### DESCRIPTION

#### Operation Description

- When the selector lever is shifted to the reverse position, the rear view monitor image is displayed.
- When the selector lever is shifted to any position other than the reverse position, the original image (the image displayed before the rear view monitor image) is displayed.

#### Camera Image Operation Principle

- The display control unit that receives the reverse signal input supplies power to the rear view camera and gives input of image signal.
- The display control unit outputs the rear view camera image to the display when the reverse signal is inputted.
- The display control unit generates the warning message, vehicle width guide lines and the predicted course lines on the image from the rear view camera, and transmits the rear view camera image signal to the front display unit.

#### Vehicle Width Guide Lines and Predicted Course Lines Display Function at Rear View Monitor Display

- The vehicle width guide lines and the predicted course lines that indicate the vehicle route according to the steering angle are displayed at the rear view monitor display to allow the driver to more easily judge distances between the vehicle and objects and help the driver back into a parking space.
- The display control unit receives the steering signal from the steering sensor via CAN communication and draws a vehicle width guide line according to the steering angle.
- When the vehicle width guide lines are displayed, the vehicle width guide lines are displayed translucently.

A  
B  
C  
D  
E  
F  
G  
H  
I  
J  
K  
L  
M

AV

# REAR VIEW MONITOR SYSTEM

< SYSTEM DESCRIPTION >

[REAR VIEW MONITOR SYSTEM]

- The predicted course lines are not displayed when the steering is in the neutral position.

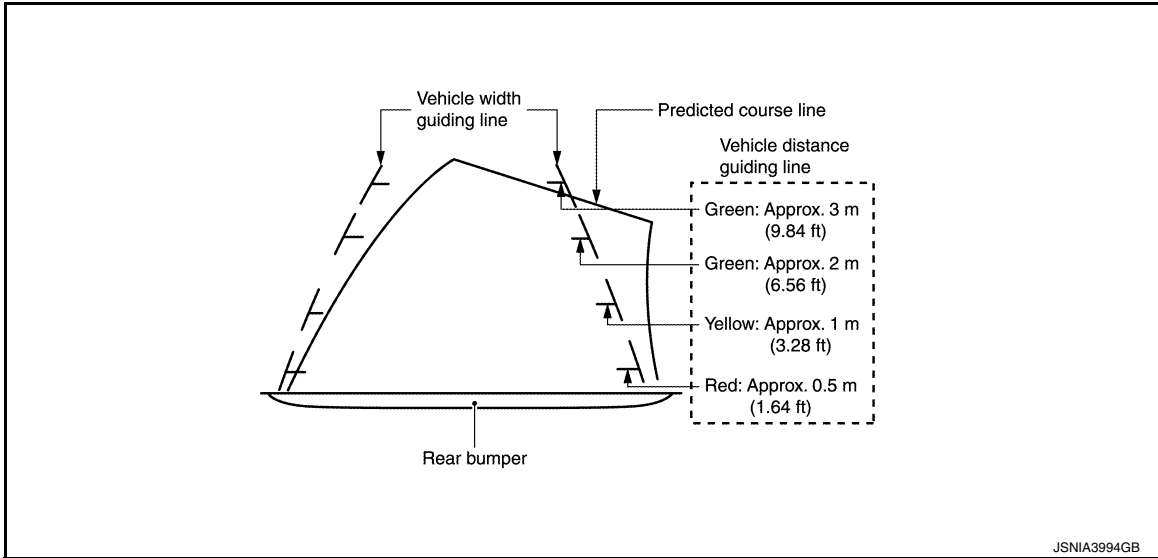

Precautions for Vehicle Width Guide Lines and Predicted Course Lines Display on the Rear View Monitor Display  
Vehicle width guide lines and predicted course lines on the display may be different from actual lines depending on vehicle conditions and road conditions.

Precautions for road conditions

# REAR VIEW MONITOR SYSTEM

## [REAR VIEW MONITOR SYSTEM]

### < SYSTEM DESCRIPTION >

- Since vehicle width guide lines and predicted course lines are drawn based on the road, a different distance may be displayed if a protruding block is present nearby.

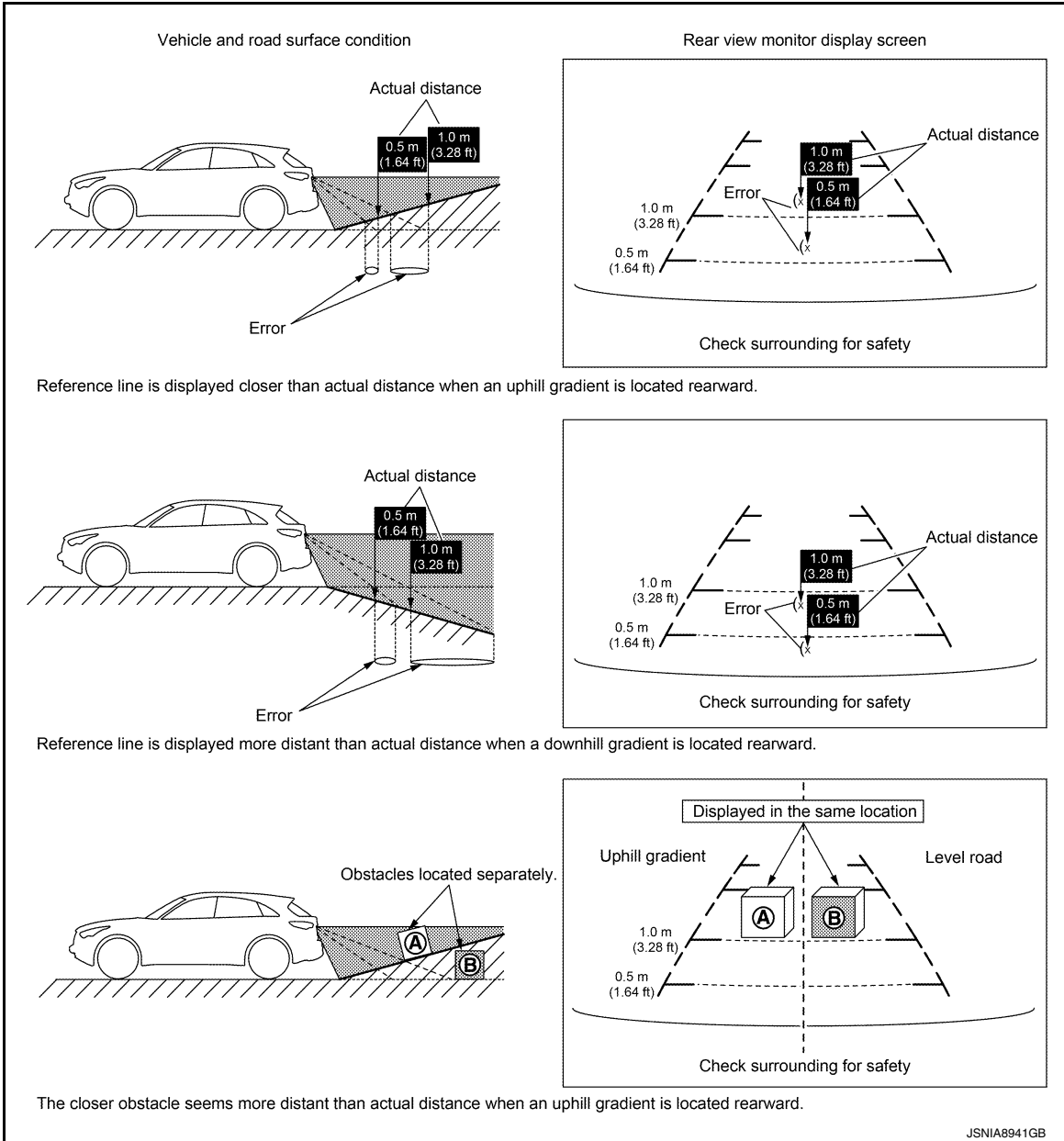

Precautions for block

A  
B  
C  
D  
E  
F  
G  
H  
I  
J  
K  
L  
M  
O  
P

AV

# REAR VIEW MONITOR SYSTEM

## [REAR VIEW MONITOR SYSTEM]

### < SYSTEM DESCRIPTION >

- Since vehicle width guide lines and predicted course lines are drawn based on the road, a different distance may be displayed if a protruding block is present nearby.

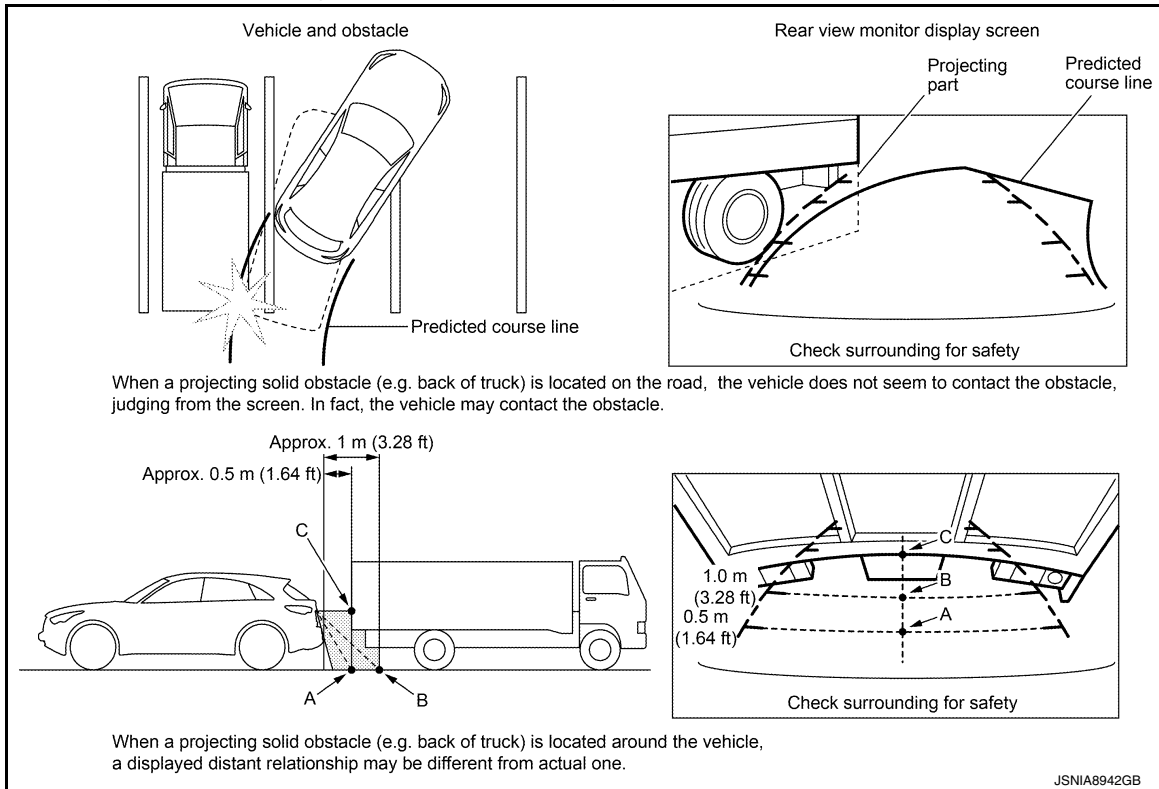



# REAR VIEW MONITOR SYSTEM

< SYSTEM DESCRIPTION >

[REAR VIEW MONITOR SYSTEM]

2.0L TURBO GASOLINE ENGINE

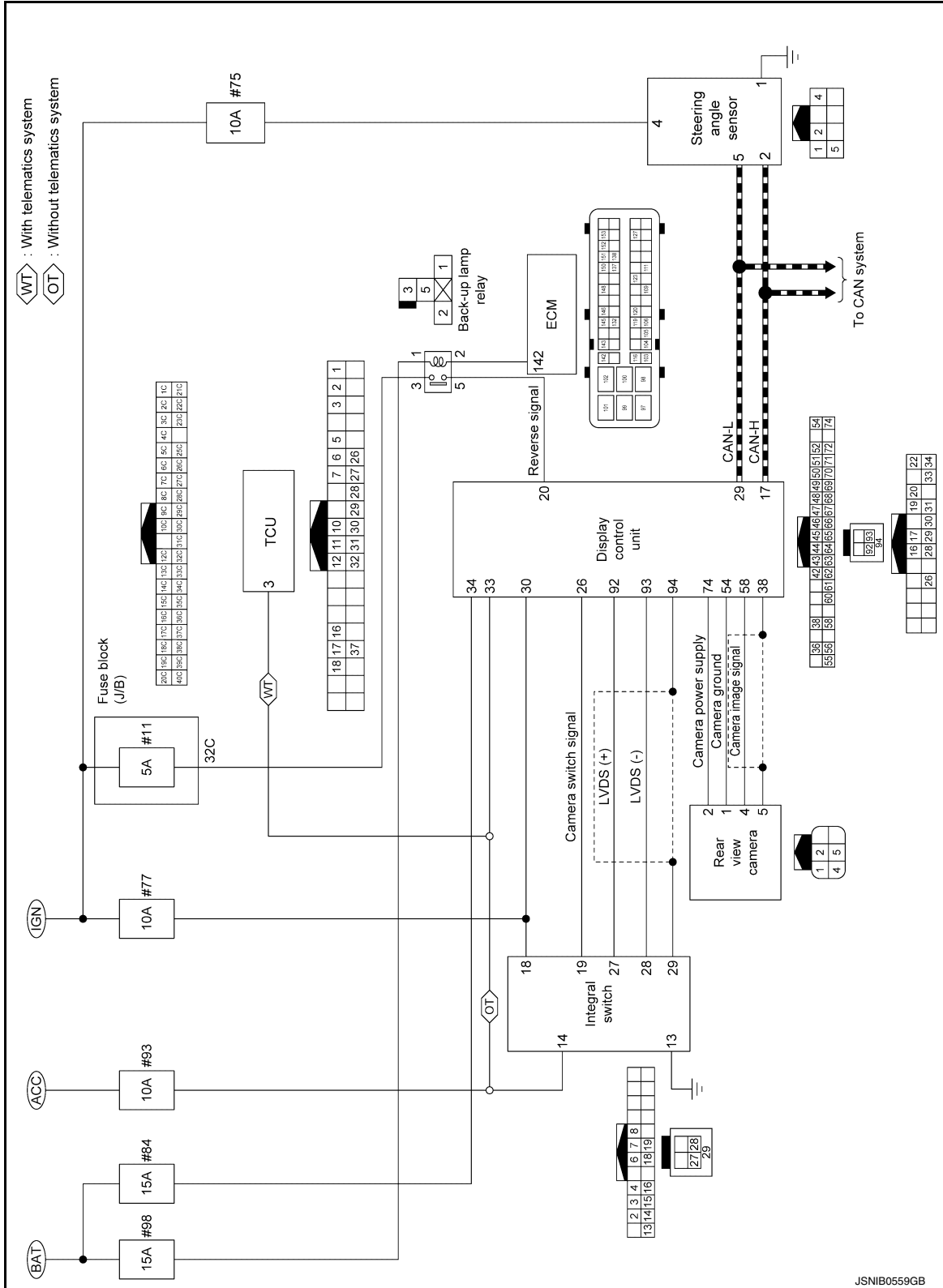

## HANDLING PRECAUTION

### Display

INFOID:000000013717619

- When the compartment temperature is low, the display images may look slower because the LCD response is deteriorated. The system will recover its normal operation when the cabin temperature increases to an appropriate level.
- When the compartment temperature is low [0°C (32°F) or less], the display images may look slower. It is characteristic of the LCD monitor and should not be considered to be a malfunction. When the temperature is at the operating temperature [0°C (32°F) to 50°C (122°F)], the display returns to normal.
- There may be small dark or bright dots in the screen or remaining display content may be found (image lag). These are inherent symptoms to any LCD monitor and should not be considered to be a malfunction.
- The image may look bright or dark when viewed obliquely from the rear. It is inherent to any LCD monitor and should not be considered to be a malfunction.
- Do not apply pressure on the LCD monitor. Doing so may cause irregularities in the screen image or render it inoperative.
- Do not use hard cloth, organic solvent (alcohol, benzene, and thinner), or chemical wipe to clean the LCD monitor. Doing so may affect the panel surface. When cleaning the LCD monitor, always wipe it with a soft cloth after shutting off the power. For severe contamination, use a soft cloth dampened with mild detergent (no droplets can be present).

### Rear View Monitor

INFOID:000000013717620

- Since the range shown on the rear view monitor is limited, be sure to check safety visually around the area. Never drive while viewing only the image. It must be used only as a supplementary measure to gain field of view at the back of the vehicle.
- Since the rear view camera is using a wide lens, distance of the image shown on the display is different from the actual distance.
- Since the rear view camera is a precision device, do not apply a strong impact to it. Doing so may cause a malfunction, fire or electric shock.
- Raindrop, snow, mud, body wax, etc. on the lens may give poor image. Damage to the lens may adversely affect the image.
- Do not use hard cloth, organic solvent (alcohol, benzene, and thinner), or chemical wipe to clean the lens. Doing so may cause discoloration. When cleaning the lens, always wipe it with a dry soft cloth. For severe contamination, use a soft cloth dampened with mild detergent (no droplets can be present).
- In a high-pressure car wash, do not expose the camera directly to water. It may cause entry of water on the lens or cause condensation, resulting in a malfunction, fire or electric shock. Do not use a car wash brush on the lens.
- When it is extremely hot or cold, the image may be poor, but it should not be considered to be a malfunction.
- The image may be poor or bluish at a dark place or at night, but it should not be considered to be a malfunction. In this case, image quality may be adjusted using the image quality adjusting function.
- Flickering may appear on the screen under fluorescent light, but it should not be considered to be a malfunction.
- When the rear view monitor is used, some of the audio and hand-free phone functions can be operated.
- It may take some time to switch to the camera image or non-camera image. Image may be instantaneously disturbed before a complete image appears.
- If highly brilliant point (sun reflecting on the vehicle body) is shown on the camera, a smear or ghost inherent to CMOS occur, but it should not be considered to be a malfunction.
- The back view monitor image is a mirror image with reverse left and right to suit the situation when the rear is viewed with the rear view mirror.
- Possible route lines and side distance guide lines are subject to the number of passengers, fuel level, vehicle position, road condition, road gradient, etc. There may be a difference from the actual driving route.
- If tires are replaced with a size not specified, possible route lines may not be correctly displayed.
- The possible route line center position may be misaligned. In this case, perform the correction of the neutral position according to the following procedure.
  - Drive 100 m (328.1 ft) or more straight ahead at 30 km/h (19 MPH) or more.

# DIAGNOSIS SYSTEM (DISPLAY CONTROL UNIT)

< SYSTEM DESCRIPTION >

[REAR VIEW MONITOR SYSTEM]

## DIAGNOSIS SYSTEM (DISPLAY CONTROL UNIT)

### Description

INFOID:0000000013974167

- The display control unit diagnosis function starts up with multifunction switch operation and the display control unit performs a diagnosis for each unit in the system during the on board diagnosis.
- Perform a CONSULT diagnosis if the on board diagnosis does not start, e.g., the screen does not display anything, the multifunction switch does not function, etc.

### On Board Diagnosis Function

INFOID:0000000013974168

#### ON BOARD DIAGNOSIS ITEM

##### Description

- The trouble diagnosis function has a self-diagnosis mode for conducting trouble diagnosis automatically and a confirmation/adjustment mode for operating manually.
- The self-diagnosis mode performs diagnoses on the display control unit, connections between system components. Then it displays the diagnosis results on the display.
- The confirmation/adjustment mode allows the technician to check, modify or adjust the vehicle signals and set values, as well as to monitor the system error records and system communication status. The checking, modifying or adjusting generally require human intervention and judgment (the system cannot make judgment automatically).

##### On Board Diagnosis Item

Mode	Description
Self Diagnosis	<ul style="list-style-type: none"><li>• Display control unit diagnosis.</li><li>• Diagnoses the connections across system components.</li></ul>

# DIAGNOSIS SYSTEM (DISPLAY CONTROL UNIT)

< SYSTEM DESCRIPTION >

[REAR VIEW MONITOR SYSTEM]

Mode	Description	
Confirmation/ Adjustment	Display Diagnosis	The following check functions are available: <ul style="list-style-type: none"> <li>• Color tone check by color bar display, white display and black display</li> <li>• Light and shade check by gray scale display</li> <li>• Touch panel check</li> <li>• Sensor sensitivity settings</li> </ul>
	Vehicle Signals	Diagnosis of signals can be performed.
	Speaker Test	The connection of a speaker can be confirmed by test tone.
	Navigation*	The reception status of GPS can be confirmed. Display On/Off of the simulation menu of navigation.
	Error History	The system malfunction and the frequency when occurring in the past are displayed. When the malfunctioning item is selected, the time and place that the selected malfunction last occurred are displayed.
	AV COMM Diagnosis	The communication condition of each unit of Infiniti InTouch can be monitored.
	Clock Setting*	The date and time information can be adjusted.
	Camera Control	The signal connected to camera control unit can be checked and the guiding line position that overlaps rear view camera image can be adjusted.
	SXM	Display the information related to satellite radio.
	Delete Unit Connection Log	Erase the connection history of unit and error history.
	Reset Settings	Initializes the each data.
	Version Information	Version information of the following items is displayed. <ul style="list-style-type: none"> <li>• Display control unit</li> <li>• NAVI control unit</li> <li>• AV control unit</li> <li>• BOSE amp.</li> <li>• Integral switch</li> <li>• Combination meter</li> <li>• Around view monitor control unit</li> </ul>
	Program Update	Version of the display control unit can be update.
	Switch Information	Display each switch information.
ANC/ASC	Display the information related to ANC and ASC.	
Hands-free Phone	The received volume adjustment of hands-free phone and microphone speaker check can be performed.	

\*: Only models with navigation system

## METHOD OF STARTING

1. Start the engine.
2. Turn the audio system OFF.
3. Touch the "Settings" icon and display a settings menu screen.

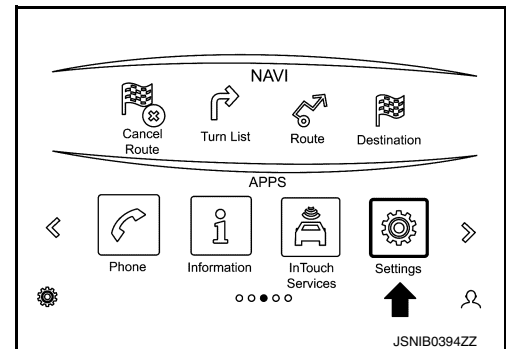

# DIAGNOSIS SYSTEM (DISPLAY CONTROL UNIT)

## [REAR VIEW MONITOR SYSTEM]

### < SYSTEM DESCRIPTION >

- Press the “SEEK·CAT/TRACK Up” switch at least 3 times. (Within 15 seconds after the settings menu screen display.)

**NOTE:**

When press the “SEEK·CAT/TRACK Up” switch more than 4 times, a self-diagnosis mode is not started. press the “MENU” switch again.

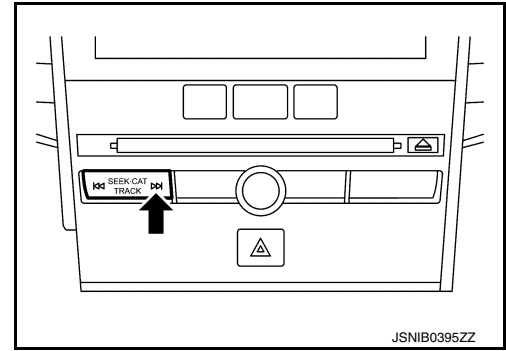

- Touch the screen (area of the figure) for 3 seconds.

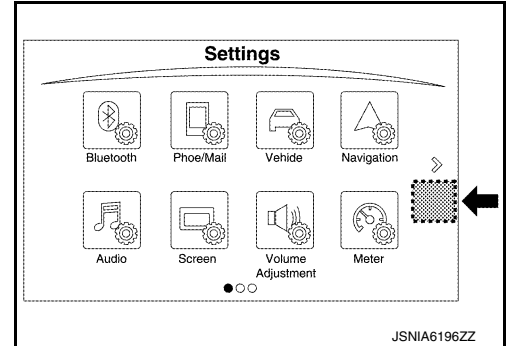

- The trouble diagnosis initial screen is displayed, and then the items of “Self Diagnosis” and “Confirmation/Adjustment” can be selected.

**NOTE:**

When a diagnostic screen is not displayed, press the “MENU” switch. And then, restart from the procedure of Step 3.

### SELF-DIAGNOSIS MODE

- Start the self-diagnosis function and select “Self Diagnosis”.
  - Self-diagnosis subdivision screen is displayed, and the self-diagnosis mode starts.
  - The bar graph visible on the center of the self-diagnosis subdivision screen indicates progress of the trouble diagnosis.
- Diagnosis results are displayed after the self-diagnosis is completed. The unit names and the connection lines are color-coded according to the diagnostic results.

Diagnosis results	Unit	Connection line
Normal	Green	Green
Connection malfunction	Gray	Yellow
Unit malfunction <sup>Note</sup>	Red	Green

**NOTE:**

Control Unit (display control unit) and BOSE Amp. are displayed in red.

- Replace display control unit if “Self-Diagnosis did not run because of a control unit malfunction” is indicated. The symptom is display control unit internal error. Refer to [AV-724. "Removal and Installation"](#).
- If multiple errors occur at the same time for a single unit, the screen switch colors are determined according to the following order of priority: red > gray.

- The comments of the self-diagnosis results can be viewed with a component in the diagnosis result screen.

#### Detection Range of Self-diagnosis Mode

- The self-diagnosis mode allows the technician to diagnose the connection in the communication line between display control unit and each unit and the internal operation of the display control unit.

# DIAGNOSIS SYSTEM (DISPLAY CONTROL UNIT)

## [REAR VIEW MONITOR SYSTEM]

### < SYSTEM DESCRIPTION >

- Because the start condition of diagnosis function is a switch operation, the on board diagnosis function cannot be started up if any malfunction is detected in the communication circuit between display control unit and multifunction switch.

### SELF-DIAGNOSIS RESULTS

Check the applicable display at the following table, and then repair the malfunctioning parts.

Only Unit Part Is Displayed In Red.

Screen switch	Description	Possible malfunction location / Action to take
DCU	Malfunction is detected in display control unit power supply and ground circuits.	Check display control unit power supply and ground circuits. Refer to <a href="#">AV-716, "DISPLAY CONTROL UNIT : Diagnosis Procedure"</a> . When detecting no malfunction in those components, replace display control unit. Refer to <a href="#">AV-724, "Removal and Installation"</a> .
Audio Head Unit	Malfunction is detected in AV control unit power supply and ground circuits.	Check AV control unit power supply and ground circuits. Refer to <a href="#">AV-391, "AV CONTROL UNIT : Diagnosis Procedure"</a> . When detecting no malfunction in those components, replace AV control unit. Refer to <a href="#">AV-432, "Removal and Installation"</a> .
Navigation unit	Malfunction is detected in NAVI control unit power supply and ground circuits.	Check NAVI control unit power supply and ground circuits. Refer to <a href="#">AV-392, "NAVI CONTROL UNIT : Diagnosis Procedure"</a> . When detecting no malfunction in those components, replace NAVI control unit. Refer to <a href="#">AV-433, "Removal and Installation"</a> .
BOSE® Amp.	When either one of the following items are detected: <ul style="list-style-type: none"> <li>• Sound signal circuits between BOSE amp. and each speaker are malfunctioning.</li> <li>• Sound signal circuits between BOSE amp. and either front or rear microphone is malfunctioning.</li> <li>• BOSE amp. malfunction is detected.</li> </ul>	<ul style="list-style-type: none"> <li>• Malfunctioning speaker circuits.</li> <li>• Malfunctioning front or rear microphone circuits.</li> <li>• Replace BOSE amp. Refer to <a href="#">AV-438, "Removal and Installation"</a>.</li> </ul>

A Connecting Cable Between Units Is Displayed In Yellow.

AV

# DIAGNOSIS SYSTEM (DISPLAY CONTROL UNIT)

< SYSTEM DESCRIPTION >

[REAR VIEW MONITOR SYSTEM]

Area with yellow connection lines	Description	Possible malfunction location / Action to take
DCU ↔ Audio Head Unit	When either one of the following items are detected: <ul style="list-style-type: none"> <li>• AV control unit power supply and ground circuits are malfunctioning.</li> <li>• AV communication circuits between display control unit and AV control unit are malfunctioning.</li> <li>• USB communication circuits between display control unit and AV control unit are malfunctioning.</li> </ul>	<ul style="list-style-type: none"> <li>• AV control unit power supply and ground circuits. Refer to <a href="#">AV-391, "AV CONTROL UNIT : Diagnosis Procedure"</a>.</li> <li>• AV communication circuits between display control unit and AV control unit are malfunctioning.</li> <li>• USB communication circuits between display control unit and AV control unit are malfunctioning.</li> </ul>
DCU ↔ Second Display	When either one of the following items are detected: <ul style="list-style-type: none"> <li>• Integral switch power supply and ground circuits are malfunctioning.</li> <li>• AV communication circuits between display control unit and integral switch are malfunctioning.</li> </ul>	<ul style="list-style-type: none"> <li>• Integral switch power supply and ground circuits. Refer to <a href="#">AV-395, "INTEGRAL SWITCH : Diagnosis Procedure"</a>.</li> <li>• AV communication circuits between display control unit and integral switch are malfunctioning.</li> </ul>
DCU ↔ BOSE® Amp	When either one of the following items are detected: <ul style="list-style-type: none"> <li>• BOSE amp. power supply and ground circuits are malfunctioning.</li> <li>• AV communication circuits between display control unit and BOSE amp. are malfunctioning.</li> </ul>	<ul style="list-style-type: none"> <li>• BOSE amp. power supply and ground circuits. Refer to <a href="#">AV-394, "BOSE AMP. : Diagnosis Procedure"</a>.</li> <li>• AV communication circuits between display control unit and BOSE amp. are malfunctioning.</li> </ul>
DCU ↔ AVM	When either one of the following items are detected: <ul style="list-style-type: none"> <li>• Around view monitor control unit power supply and ground circuits are malfunctioning.</li> <li>• AV communication circuits between display control unit and around view monitor control unit are malfunctioning.</li> </ul>	<ul style="list-style-type: none"> <li>• Around view monitor control unit power supply and ground circuits. Refer to <a href="#">AV-627, "AROUND VIEW MONITOR CONTROL UNIT : Diagnosis Procedure"</a>.</li> <li>• AV communication circuits between display control unit and around view monitor control unit are malfunctioning.</li> </ul>
DCU ↔ Meter	When either one of the following items are detected: <ul style="list-style-type: none"> <li>• Combination meter power supply and ground circuits are malfunctioning.</li> <li>• AV communication circuits between display control unit and combination meter are malfunctioning.</li> </ul>	<ul style="list-style-type: none"> <li>• Combination meter power supply and ground circuits. Refer to <a href="#">MWI-125, "COMBINATION METER : Diagnosis Procedure"</a>.</li> <li>• AV communication circuits between display control unit and combination meter are malfunctioning.</li> </ul>
DCU ↔ Rear Camera	Malfunction is detected in rear view camera circuit between display control unit and rear view camera.	Rear view camera power supply and ground circuits. Refer to <a href="#">AV-355, "Diagnosis Procedure"</a> .
Navigation unit ↔ GPS Antenna	GPS antenna connection malfunctions detected.	GPS antenna Refer to <a href="#">AV-338, "Diagnosis Procedure"</a> .
Audio Head Unit ↔ SXM Antenna	Satellite antenna connection malfunctions detected.	Satellite antenna Refer to <a href="#">AV-343, "Diagnosis Procedure"</a> .
Audio Head Unit ↔ Radio Antenna	Window antenna connection malfunctions detected.	Window antenna Refer to <a href="#">AV-359, "Diagnosis Procedure"</a> .
Second Display ↔ IT Commander	Multifunction switch connection malfunctions detected.	Multifunction switch Refer to <a href="#">AV-357, "Diagnosis Procedure"</a> .
DCU ↔ Navigation unit	USB communication circuits between display control unit and NAVI control unit are malfunctioning.	USB communication circuits between display control unit and NAVI control unit are malfunctioning. Refer to <a href="#">AV-349, "Diagnosis Procedure"</a> .
DCU ↔ TCU2	USB communication circuits between display control unit and TCU are malfunctioning.	USB communication circuits between display control unit and TCU are malfunctioning. Refer to <a href="#">AV-350, "Diagnosis Procedure"</a> .

# DIAGNOSIS SYSTEM (DISPLAY CONTROL UNIT)

[REAR VIEW MONITOR SYSTEM]

< SYSTEM DESCRIPTION >

## CONFIRMATION/ADJUSTMENT MODE

1. Start the diagnosis function and select "Confirmation/Adjustment". The confirmation/adjustment mode indicates where each item can be checked or adjusted.
2. Select each switch on the "Confirmation/Adjustment Mode" screen to display the relevant trouble diagnosis screen. Touch the "Back" to return to the initial Confirmation/Adjustment Mode screen.

### Display Diagnosis

Confirmation of the display control unit screen and integral switch screen.

Item	Description	
Display Settings	<ul style="list-style-type: none"> <li>• Display 8 colors of following bars.</li> <li>- White</li> <li>- Yellow</li> <li>- Cyan (Close to light blue)</li> <li>- Green</li> <li>- Magenta (Close to purplish red)</li> <li>- Red</li> <li>- Blue</li> <li>- Black</li> <li>- Gray Scale</li> </ul>	
	Gradation Bar	Display 64 gradation gray-scale image to a screen.
	White Display	Display white screen.
	Black Display	Display black screen.
Touch Panel	<ul style="list-style-type: none"> <li>• The function can check the presence of a "+" indication and deviation from where it should be while touching the touch panel.</li> <li>• Display coordinates and gesture operation name (Drag, Tap, Double Tap, Spread, etc.) of the screen which touched.</li> </ul>	
Sensor Sensitivity Settings	<ul style="list-style-type: none"> <li>• Display a current touch panel sensor sensitivity set value.</li> <li>• Can change the touch panel sensor sensitivity set value with 1 (Low) - 5 (high) phases.</li> </ul> <p><b>NOTE:</b> The set value is the same as display control unit screen and integral switch screen.</p>	

### Vehicle Signals

A comparison check can be made of each actual vehicle signal and the signals recognized by the system.

#### Display control unit

Diagnosis item	Display	Vehicle status	Remarks
Vehicle Speed	ON	Vehicle speed > 0 km/h (0 MPH)	Changes in indication may be delayed. This is normal.
	OFF	Vehicle speed = 0 km/h (0 MPH)	
Parking Brake Signal	ON	Parking brake is applied.	
	OFF	Parking brake is released.	
Light Signal	ON	Block the light beam from the auto light optical sensor when the light switch is ON.	—
	OFF	Either of the following conditions <ul style="list-style-type: none"> <li>• Lighting switch OFF.</li> <li>• Expose the auto light optical sensor to light when the light switch is ON.</li> </ul>	
Ignition Signal	ON	Ignition switch ON.	—
	OFF	Ignition switch in ACC position.	
Reverse Signal	ON	Shift the selector lever to "R" position.	Changes in indication may be delayed. This is normal.
	OFF	Shift the selector lever other than "R" position.	

# DIAGNOSIS SYSTEM (DISPLAY CONTROL UNIT)

[REAR VIEW MONITOR SYSTEM]

## < SYSTEM DESCRIPTION >

### NAVI control unit

Diagnosis item	Display	Vehicle status	Remarks
Vehicle Speed	ON	Vehicle speed > 0 km/h (0 MPH)	Changes in indication may be delayed. This is normal.
	OFF	Vehicle speed = 0 km/h (0 MPH)	
Ignition Signal	ON	Ignition switch ON.	—
	OFF	Ignition switch in ACC position.	
Reverse Signal	ON	Shift the selector lever to "R" position.	Changes in indication may be delayed. This is normal.
	OFF	Shift the selector lever other than "R" position.	

### NOTE:

Only models with navigation system.

### Speaker Test

Select "Speaker Test" to display the speaker diagnosis screen. Touch "Start" to generate a test tone in a speaker. Touch "Next" to generate a test tone in the next speaker. Touch "End" to stop the test tones.

### Navigation

Item	Description
Sensor Information	The reception status of GPS can be confirmed.
Route Simulation	Set the display ON/OFF of the "simulation" menu of the navigation.

### NOTE:

Only models with navigation system.

### Error History

The self-diagnosis results are judged depending on whether any error occurs from when "Self-diagnosis" is selected until the self-diagnosis results are displayed.

However, the diagnosis results are judged normal if an error has occurred before the ignition switch is turned ON and then no error has occurred until the self-diagnosis start. Check the "Error Record" to detect any error that may have occurred before the self-diagnosis start because of this situation.

The error record displays the time and place of the most recent occurrence of that error. However, take note of the following points.

- Place of the error occurrence is represented by the longitude and latitude at the time an error occurred. If current location mark has deviated from the correct position, then the place of the error occurrence cannot be located correctly.
- The frequency of occurrence is displayed in a up-and-down manner.

### Count up method

- The counter resets to 0 if an error occurs when ignition switch is turned ON. The counter increases by 1 if the condition is normal at a next ignition ON cycle.
- The counter upper limit is 39. Any counts exceeding 39 are ignored. The counter can be reset (no error record display) with the "Delete log" switch or CONSULT.

Display type of occurrence frequency	Error history display item
Count up method	CAN communication line, control unit (CAN), AV communication line, control unit (AV)

### Error item

Some error items may be displayed simultaneously according to the cause. If some error items are displayed simultaneously, the detection of the cause can be performed by the combination of display items

Error item	Applicable DTC	Reference
TACHO signal failure	B1F01	<a href="#">AV-295</a>
Compensat. mic1 IN: Open	B1F0B	<a href="#">AV-304</a>
Compensat. mic1 IN: Short	B1F0C	<a href="#">AV-304</a>
Compensat. mic1 IN: Short to battery	B1F0D	<a href="#">AV-304</a>

# DIAGNOSIS SYSTEM (DISPLAY CONTROL UNIT)

< SYSTEM DESCRIPTION >

[REAR VIEW MONITOR SYSTEM]

Error item	Applicable DTC	Reference	
Compensat. mic1 IN: Short to ground	B1F0E	<a href="#">AV-304</a>	A
Compensat. mic2 IN: Open	B1F10	<a href="#">AV-309</a>	
Compensat. mic2 IN: Short	B1F11	<a href="#">AV-309</a>	B
Compensat. mic2 IN: Short to battery	B1F12	<a href="#">AV-309</a>	
Compensat. mic2 IN: Short to ground	B1F13	<a href="#">AV-309</a>	
Compensat. mic3 IN: Open	B1F15	<a href="#">AV-314</a>	C
Compensat. mic3 IN: Short	B1F16	<a href="#">AV-314</a>	
Compensat. mic3 IN: Short to battery	B1F17	<a href="#">AV-314</a>	D
Compensat. mic3 IN: Short to ground	B1F18	<a href="#">AV-314</a>	
CAN COMM CIRCUIT	U1000	<a href="#">AV-327</a>	
CONTROL UNIT (CAN)	U1010	<a href="#">AV-330</a>	E
Control unit internal error	U121F	<a href="#">AV-332</a>	
Mismatched configuration data stored	U1223	<a href="#">AV-333</a>	F
Amplifier temperature error	U1231	<a href="#">AV-334</a>	
Steer. Angle Sensor calibration	U1232	<a href="#">AV-335</a>	
Navi unit internal error	U1233	<a href="#">AV-336</a>	G
Audio unit internal error	U1234	<a href="#">AV-337</a>	
Audio unit connection error	U1249	<a href="#">AV-339</a>	H
GPS Antenna error	U1244	<a href="#">AV-338</a>	
Bose AMP connection error	U124E	<a href="#">AV-341</a>	
XM Antenna connection error : open	U1258	<a href="#">AV-343</a>	I
XM Antenna connection error : short			
2nd Display connection error	U1259	<a href="#">AV-345</a>	
AVM connection error	U125B	<a href="#">AV-347</a>	J
Navi unit connection error	U125D	<a href="#">AV-349</a>	
TCU connection error	U1266	<a href="#">AV-350</a>	K
Cluster connection error	U1267	<a href="#">AV-352</a>	
Confirm user connection unit	U12B7	<a href="#">AV-354</a>	
Rear Camera connection error	U12B8	<a href="#">AV-355</a>	L
IT Comander connection error	U12BA	<a href="#">AV-357</a>	
Radio Antenna error : open	U12BE	<a href="#">AV-359</a>	M
Radio Antenna error : short			
AV COMM CIRCUIT	U1300	<a href="#">AV-361</a>	
CONTROL UNIT (AV)	U1310	<a href="#">AV-363</a>	AV
FL-DOOR speaker OUT: open	U1600	<a href="#">AV-364</a>	O
FL-DOOR speaker OUT: short			
FL-DOOR speaker OUT: short to ground			
FL-DOOR speaker OUT: short to battery			
FL-DOOR woofer OUT: open	U1601	<a href="#">AV-367</a>	P
FL-DOOR woofer OUT: short			
FL-DOOR woofer OUT: short to ground			
FL-DOOR woofer OUT: short to battery			

# DIAGNOSIS SYSTEM (DISPLAY CONTROL UNIT)

< SYSTEM DESCRIPTION >

[REAR VIEW MONITOR SYSTEM]

Error item	Applicable DTC	Reference
FL-DOOR squawker OUT: open	U1602	<a href="#">AV-370</a>
FL-DOOR squawker OUT: short		
FL-DOOR squawker OUT: short to ground		
FL-DOOR squawker OUT: short to battery		
FL-DOOR tweeter OUT: open	U1603	<a href="#">AV-373</a>
FL-DOOR tweeter OUT: short		
FL-DOOR tweeter OUT: short to ground		
FL-DOOR tweeter OUT: short to battery		
FR-DOOR speaker OUT: open	U1608	<a href="#">AV-364</a>
FR-DOOR speaker OUT: short		
FR-DOOR speaker OUT: short to ground		
FR-DOOR speaker OUT: short to battery		
FR-DOOR woofer OUT: open	U1609	<a href="#">AV-367</a>
FR-DOOR woofer OUT: short		
FR-DOOR woofer OUT: short to ground		
FR-DOOR woofer OUT: short to battery		
FR-DOOR squawker OUT: open	U160A	<a href="#">AV-370</a>
FR-DOOR squawker OUT: short		
FR-DOOR squawker OUT: short to ground		
FR-DOOR squawker OUT: short to battery		
FR-DOOR tweeter OUT: open	U160B	<a href="#">AV-373</a>
FR-DOOR tweeter OUT: short		
FR-DOOR tweeter OUT: short to ground		
FR-DOOR tweeter OUT: short to battery		
F-INST L-squawker OUT: open	U1626	<a href="#">AV-376</a>
F-INST L-squawker OUT: short		
F-INST L-squawker OUT: short to ground		
F-INST L-squawker OUT: short to battery		
F-INST C-squawker OUT: open	U162A	<a href="#">AV-379</a>
F-INST C-squawker OUT: short		
F-INST C-squawker OUT: short to ground		
F-INST C-squawker OUT: short to battery		
F-INST R-squawker OUT: open	U162E	<a href="#">AV-376</a>
F-INST R-squawker OUT: short		
F-INST R-squawker OUT: short to ground		
F-INST R-squawker OUT: short to battery		
RL-SIDE squawker OUT: open	U1716	<a href="#">AV-381</a>
RL-SIDE squawker OUT: short		
RL-SIDE squawker OUT: short to ground		
RL-SIDE squawker OUT: short		
RR-SIDE squawker OUT: open	U171E	<a href="#">AV-381</a>
RR-SIDE squawker OUT: short		
RR-SIDE squawker OUT: short to ground		
RR-SIDE squawker OUT: short		

# DIAGNOSIS SYSTEM (DISPLAY CONTROL UNIT)

< SYSTEM DESCRIPTION >

[REAR VIEW MONITOR SYSTEM]

Error item	Applicable DTC	Reference
R-PSHELF L-speaker OUT: open	U1720	<a href="#">AV-384</a>
R-PSHELF L-speaker OUT: short		
R-PSHELF L-speaker OUT: short to ground		
R-PSHELF L-speaker OUT: short to battery		
R-PSHELF L-woofer OUT: open	U1721	<a href="#">AV-387</a>
R-PSHELF L-woofer OUT: short		
R-PSHELF L-woofer OUT: short to ground		
R-PSHELF L-woofer OUT: short to battery		
R-PSHELF R-speaker OUT: open	U1728	<a href="#">AV-384</a>
R-PSHELF R-speaker OUT: short		
R-PSHELF R-speaker OUT: short to ground		
R-PSHELF R-speaker OUT: short to battery		
R-PSHELF R-woofer OUT: open	U1729	<a href="#">AV-387</a>
R-PSHELF R-woofer OUT: short		
R-PSHELF R-woofer OUT: short to ground		
R-PSHELF R-woofer OUT: short to battery		

## AV COMM Diagnosis

### AV COMM Monitor

- Displays the communication status between display control unit (master unit) and each unit.
- The error counter displays “OK” if any malfunction was not detected in the past and displays “0” if a malfunction is detected. It increases by 1 if the condition is normal at the next ignition switch ON cycle. The upper limit of the counter is 39.
- The error counter is erased if “Reset” is pressed.

Items	Status (Current)	Counter (Past)
CMF Send Switch	OK / UNKW	OK / 0 – 39 / —
CMF Receive 2ndDisp	OK / UNKW	OK / 0 – 39 / —
CMF Receive Bose AMP	OK / UNKW	OK / 0 – 39 / —
CMF Receive AVM	OK / UNKW	OK / 0 – 39 / —
CMF Receive Meter	OK / UNKW	OK / 0 – 39 / —
CMF Receive TCU2	OK / UNKW	OK / 0 – 39 / —
CMF Receive Audio	OK / UNKW	OK / 0 – 39 / —

### Clock Setting

The date and time information can be adjusted.

#### NOTE:

Only models with navigation system.

### Camera Control

Item	Description
Adjust Guide Line of Rear View Cam	The guiding lines in the rear view monitor can be adjusted.
Check/Change Configuration	Displays the current configuration data. <b>NOTE:</b> Refer to the following list for the items of the configuration adjustment function.
Reset Configuration	Initializes the camera system configuration.
Camera System Type	Sets the type of camera that is connected.

# DIAGNOSIS SYSTEM (DISPLAY CONTROL UNIT)

< SYSTEM DESCRIPTION >

[REAR VIEW MONITOR SYSTEM]

## Configuration list

Setting item	Setting (Default value)		
	With direct adaptive steering	Without direct adaptive steering	
		Except VR30DDTT engine (2WD) with paddle shifter models	VR30DDTT engine (2WD) with paddle shifter models
Predictive Course Lines	Normal	Normal	Quick
Rear Coeff. K	1.37847	1.37847	1.37847
Rear Coeff. F	0.0394	0.0394	0.0394
Rear Coeff. P1	-0.24463	-0.24463	-0.24463
Rear Coeff. P2	0.07005	0.07005	0.07005
Rear Coeff. C1	-0.00608	-0.00608	-0.00608
Rear Coeff. C2	-0.00001	-0.00001	-0.00001
Rear Coeff. D1	130.6	130.6	130.6
Rear Coeff. D2	-35	-35	-35
Car Width	1852.8	1852.8	1852.8
Rear Offset	3696.5	3696.5	3696.5
Rear Height	666.2	666.2	666.2
Rear L/R Angle	0	0	0
Rear Up/Dn Angle	0	0	0
Rear Roll Angle	0	0	0
Bumper Rear Dist.	0	0	0
Bumper Rear Ax Dist	0	0	0
Max. Steering Angle	32.46	32.46	31.56
Min. Turning Radius	1.511	1.511	1.338
Wheelbase	2850	2850	2850
Total Length	4683	4683	4683
Steering Gear Ratio	0.036	0.036	0.03
Tot.Width With Mirrors	0	0	0

SMX

## XM Mode Diagnosis

Item	Description
Show XM Diagnosis	Display adjustment items to test satellite radio function.
External Connection Mode	Set in external diagnostic mode.

## Delete Unit Connection Log

Deletes any unit connection records and error records from the display control unit memory. (Clear the records of the unit that has been removed.)

## Reset Settings

Item	Description
Reset User Data	Initializes the display control unit, NAVI control unit and AV control unit memory.
Reset Configuration	Initializes the configuration data.

## Version Information

Version information of the each control unit and switch is displayed.

## Program Update

Version of the display control unit can be update.

# DIAGNOSIS SYSTEM (DISPLAY CONTROL UNIT)

[REAR VIEW MONITOR SYSTEM]

## < SYSTEM DESCRIPTION >

### Switch Information

Steering switch, multifunction switch and integral switch information can be checked.  
Switch name and ID are displayed when press each switch.

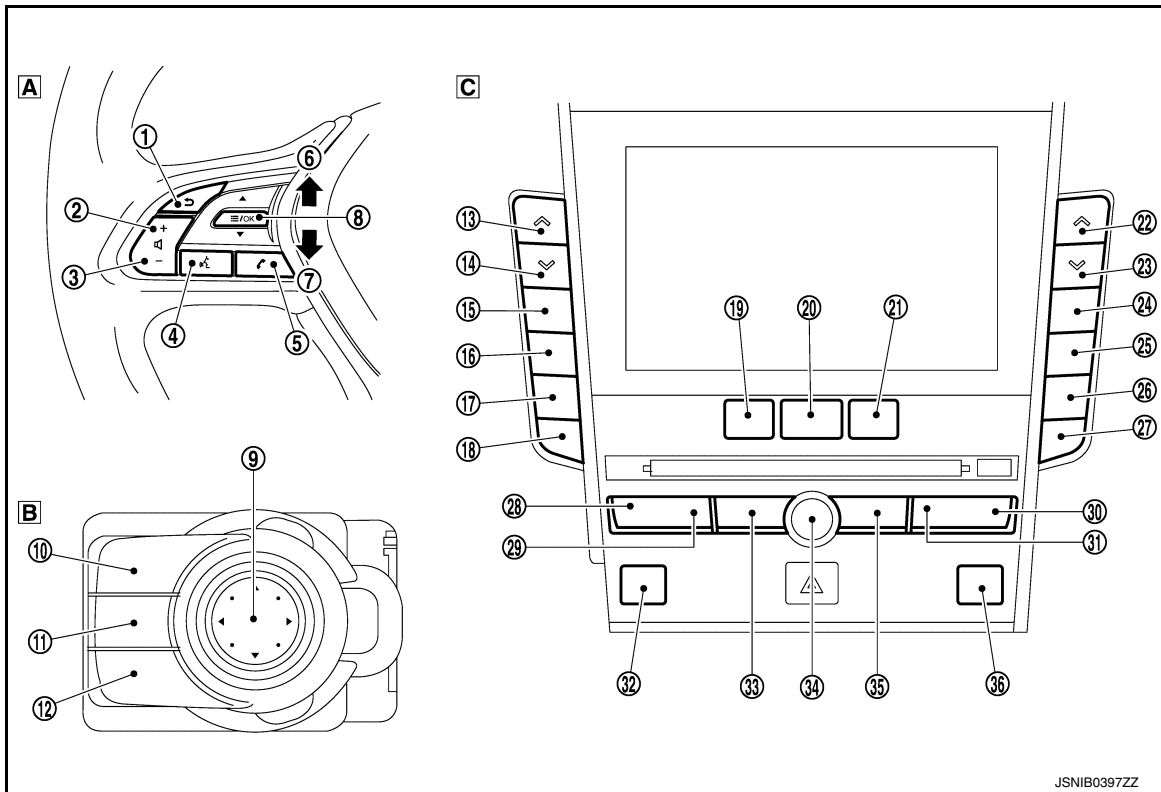

**A** Steering switch

**B** Multifunction switch

**C** Integral switch

No.	Display name	Switch position
①	Source	Steering switch
②	VOL UP/Right	
③	VOL DOWN/Left	
④	Voice Recognition Engine:	
⑤	Phone	
⑥	MENU UP	
⑦	MENU DOWN	
⑧	Enter	
⑨	OK	Multifunction switch
⑩	MAP	
⑪	Back	
⑫	Not displayed	

A  
B  
C  
D  
E  
F  
G  
H  
I  
J  
K  
L  
M  
AV  
O  
P

# DIAGNOSIS SYSTEM (DISPLAY CONTROL UNIT)

< SYSTEM DESCRIPTION >

[REAR VIEW MONITOR SYSTEM]

No.	Display name	Switch position
⑬	Temperature	Integral switch
⑭	Temperature	
⑮	Auto	
⑯	Wind Speed +	
⑰	Wind Speed -	
⑱	MODE	
⑲	Audio	
⑳	Menu	
㉑	Climate	
㉒	Temperature	
㉓	Temperature	
㉔	Recirculation	
㉕	Front Defrost	
㉖	Rear Defrost	
㉗	OFF	
㉘	⏪	
㉙	⏩	
㉚	TUNE/CH/HOLDER>	
㉛	<TUNE/CH/HOLDER	
㉜	Seat Heater (Left Seat)	
㉝	Radio	
㉞	Not displayed	
㉟	DISC/AUX	
㊱	Seat Heater (Right Seat)	

## ANC/ASC

Item	Description
ANC/ASC Diagnosis	Show Settings Following items can be confirmed. <ul style="list-style-type: none"> <li>• Part number</li> <li>• Config result</li> <li>• Active noise cancellation system ON/OFF status</li> <li>• Active sound enhancement system ON/OFF status</li> </ul>
	Connection Diagnosis Display a state of wiring connected with in BOSE amp.
	Active Test Active noise cancellation system function can be confirmed by test tone.
	Version Active noise cancellation system and active sound enhancement system function ON/OFF can be set.

## Hands-Free Phone

The hands-free phone reception volume adjustment and microphone and speaker test functions are also available.

Item	Description
HF Vol. Adjustment	The reception volume can be set in three steps: "Low", "Standard" and "High".

# DIAGNOSIS SYSTEM (DISPLAY CONTROL UNIT)

[REAR VIEW MONITOR SYSTEM]

< SYSTEM DESCRIPTION >

Item	Description
Voice Microphone Test	The microphone audio can be directly connected to the speakers to perform a microphone test.
Onload model ID	Displays the on board unit ID.

## CONSULT Function

INFOID:000000013974169

## APPLICATION ITEMS

CONSULT performs the following functions via the communication with the display control unit

Diagnosis mode	Description
Self Diagnostic Result	Performs a diagnosis on the display control unit and a connection diagnosis for the communication circuit of the Multi AV system, and displays the current and past malfunctions collectively.
Data Monitor	The diagnosis of vehicle signal that is input to the display control unit can be performed.
Work Support	Steering angle sensor can be adjusted.
ECU Identification	The part number of display control unit can be checked.
Configuration	<ul style="list-style-type: none"> <li>Read and save the vehicle specification.</li> <li>Write the vehicle specification when replacing display control unit</li> </ul>

## AV communication

When "AV communication" of "CAN Diag Support Monitor" is selected, the following function will be performed.

AV communication	AV&NAVI C/U	Displays the communication status from display control unit to each unit as well as the error counter.
	AUDIO	Displays the display control unit communication status and the error counter.

## SELF DIAGNOSIS RESULT

- In CONSULT self-diagnosis, self-diagnosis results and error history are displayed collectively.
- The current malfunction indicates "CRNT". The past malfunction indicates "PAST".
- The timing is displayed as "0" if any of the error codes U1000, U1010, U1300 and U1310 is detected. The counter increases by 1 if the condition is normal at the next ignition switch ON cycle.
- Refer to [AV-695. "DTC Index"](#).

## Freeze Frame Data (FFD)

The following vehicle status is recorded when DTC is detected and is displayed on CONSULT.

Item name	Display content
ODO/TRIP METER (km)	Total driving distance (odometer value) upon DTC detection is displayed.
TOTAL DISTANCE (km)	

## DATA MONITOR

### NOTE:

The following table includes information (items) inapplicable to this vehicle. For information (items) applicable to this vehicle, refer to CONSULT display items.

- Displays the status of the following vehicle signals inputted into the display control unit.
- For each signal, actual signal can be compared with the condition recognized on the system.

Display Item	Display	Vehicle status	Remarks
VHCL SPD SIG	On	Vehicle speed > 0 km/h (0 MPH)	Changes in indication may be delayed. This is normal.
	Off	Vehicle speed = 0 km/h (0 MPH)	
PKB SIG	On	Parking brake is applied.	
	Off	Parking brake is released.	

# DIAGNOSIS SYSTEM (DISPLAY CONTROL UNIT)

< SYSTEM DESCRIPTION >

[REAR VIEW MONITOR SYSTEM]

Display Item	Display	Vehicle status	Remarks
ILLUM SIG	On	Block the light beam from the auto light optical sensor when the light switch is ON.	—
	Off	Either of the following conditions <ul style="list-style-type: none"> <li>• Lighting switch OFF.</li> <li>• Expose the auto light optical sensor to light when the light switch is ON.</li> </ul>	
IGN SIG	On	Ignition switch ON.	
	Off	Ignition switch in ACC position.	
REV SIG	On	Selector lever in R position.	Changes in indication may be delayed. This is normal.
	Off	Selector lever in any position other than R.	

## WORK SUPPORT

Adjusts the neutral position of the steering angle sensor.

### CAUTION:

**For vehicles with VDC, adjust the steering angle sensor neutral position on the ABS actuator control unit side. Refer to [BRC-92, "Description"](#).**

Item	Description
ST ANGLE SENSOR ADJUSTMENT	<b>NOTE:</b> This item is displayed, but not used.

## ECU IDENTIFICATION

The part number of display control unit is displayed.

## CONFIGURATION

Configuration has three functions as follows.

Function	Description	
Read/Write Configuration	Before Replace ECU	Allows the reading of vehicle specification written in display control unit to store the specification in CONSULT.
	After Replace ECU	Allows the writing of the vehicle information stored in CONSULT into the display control unit.
Manual Configuration	Allows the writing of the vehicle specification into the display control unit by hand.	

### CAUTION:

- When replacing display control unit, you must perform “Read / Write Configuration” or “Manual Configuration” with CONSULT.
- Complete the procedure of “Read / Write Configuration” or “Manual Configuration” in order.
- If you set incorrect “Read / Write Configuration” or “Manual Configuration”, incidents might occur.
- Configuration is different for each vehicle model. Confirm configuration of each vehicle model.

# DISPLAY CONTROL UNIT

< ECU DIAGNOSIS INFORMATION >

[REAR VIEW MONITOR SYSTEM]

## ECU DIAGNOSIS INFORMATION

### DISPLAY CONTROL UNIT

#### Reference Value

INFOID:0000000013974163

#### VALUES ON THE DIAGNOSIS TOOL

**NOTE:**

The following table includes information (items) inapplicable to this vehicle. for information (items) applicable to this vehicle, refer to CONSULT display items.

Monitor Item	Condition		Value/Status
VHCL SPD SIG	Ignition switch ON	Vehicle speed > 0 km/h (0 MPH)	On
		Vehicle speed = 0 km/h (0 MPH)	Off
PKB SIG	Ignition switch ON	Parking brake is applied.	On
		Parking brake is released.	Off
ILLUM SIG	Ignition switch ON	Block the light beam from the auto light optical sensor when the light switch is ON.	On
		Expose the auto light optical sensor to light when the light switch is OFF or ON.	Off
IGN SIG	Ignition switch ON.		On
	Ignition switch ACC.		Off
REV SIG	Ignition switch ON	Selector lever in R position.	On
		Selector lever in any position other than R.	Off

#### TERMINAL LAYOUT

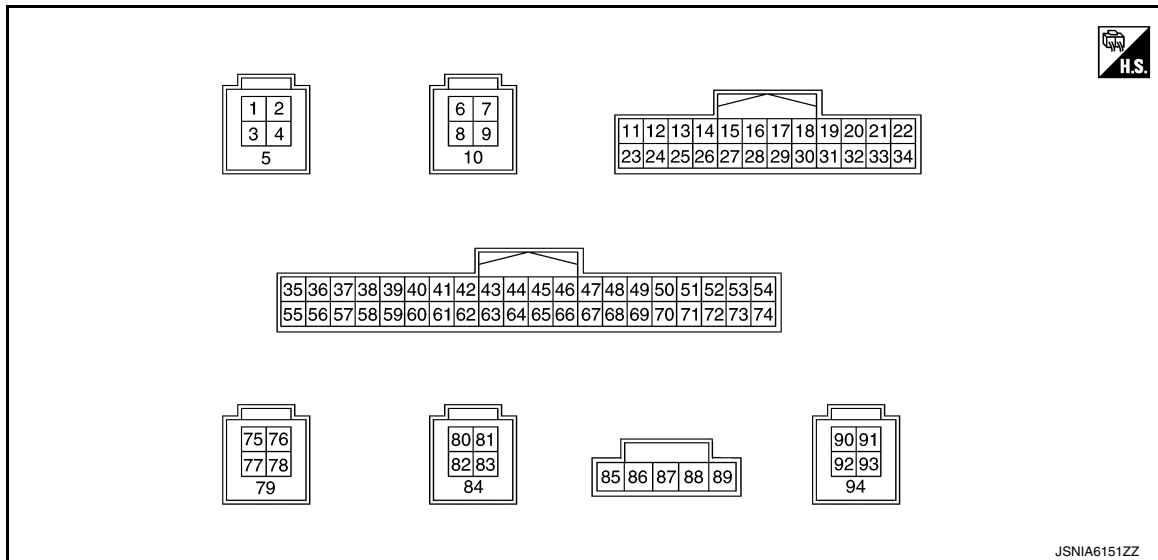

#### PHYSICAL VALUES

Terminal (Wire color)		Description		Condition	Reference value (Approx.)
+	-	Signal name	Input/Output		
1 (G)	—	USB ground	—	—	—
2 (W)	—	USB V BUS signal	Output	—	—

# DISPLAY CONTROL UNIT

< ECU DIAGNOSIS INFORMATION >

[REAR VIEW MONITOR SYSTEM]

Terminal (Wire color)		Description		Condition	Reference value (Approx.)
+	-	Signal name	Input/ Output		
3 (R)	—	USB D- signal	Input/ Output	—	—
4 (L)	—	USB D+ signal	Input/ Output	—	—
5 (—)	—	Shield	—	—	—
6 (G)	—	USB ground	—	—	—
7 (W)	—	USB V BUS signal	Output	—	—
8 (R)	—	USB D- signal	Input/ Output	—	—
9 (L)	—	USB D+ signal	Input/ Output	—	—
10 (—)	—	Shield	—	—	—
16 (LG)	—	AV communication signal (L)	Input/ Output	—	—
17 (P)	—	CAN-L	Input/ Output	—	—
19 (R)	22 (B)	Dimmer signal	Input	[Ignition switch ON] • Either of the following conditions - Lighting switch OFF - Expose the auto light optical sensor to light when the light switch is ON.	0 V
				[Ignition switch ON] • Block the light beam from the auto light optical sensor when the light switch is ON.	12.0 V
20 (BR)	22 (B)	Reverse signal	Input	[Ignition switch ON] • R position	12.0 V
				[Ignition switch ON] • Other than R position	0 V
22 (B)	—	Ground	—	[Ignition switch ON]	0 V
26 (BR)	22 (B)	Camera switch signal	Input	[Ignition switch ON] • Camera switch: ON	0 - 2.5 V
				[Ignition switch ON] • Camera switch: OFF	3.0 V
28 (SB)	—	AV communication signal (H)	Input/ Output	—	—
29 (L)	—	CAN-H	Input/ Output	—	—
30 (W) <sup>*1</sup> (R) <sup>*2</sup>	22 (B)	Ignition signal	Input	[Ignition switch ON]	Battery voltage

# DISPLAY CONTROL UNIT

< ECU DIAGNOSIS INFORMATION >

[REAR VIEW MONITOR SYSTEM]

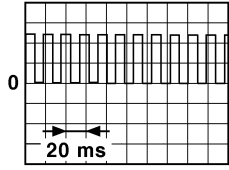
Terminal (Wire color)		Description		Condition	Reference value (Approx.)
+	-	Signal name	Input/ Output		
31 (R)	22 (B)	Vehicle speed signal (8-pulse)	Input	[Ignition switch ON] • When vehicle speed is approx. 40 km/h (25 MPH)	<b>NOTE:</b> The maximum voltage varies depending on the specification (destination unit).   <small>JSNIA0012GB</small>
33 (SB)	22 (B)	ACC power supply	Input	[Ignition switch ACC]	Battery voltage
34 (Y)	22 (B)	Battery power supply	Input	[Ignition switch OFF]	Battery voltage
36 (LG)	—	Composite image signal (-)	—	—	—
38 (—)	—	Shield	—	—	—
40*3 (—)	—	Manufacturer specific signal	—	—	—
42 (G)	—	Sound signal RH (-)	—	—	—
43 (—)	—	Shield	—	—	—
44 (L)	—	Sound signal LH (-)	—	—	—
45 (W)	—	TEL voice signal (-)	—	—	—
46 (—)	—	Shield	—	—	—
47 (R)	—	Voice guidance signal output (-)	—	—	—
48 (B)	—	Voice guidance signal input (-)	—	—	—
49 (W)	—	NS ON/OFF signal	—	—	—
50 (R)	—	Microphone signal ground (With navigation)	—	[Ignition switch ON]	0 V
51 (—)	—	Shield	—	—	—
52 (—)	—	Microphone signal ground	—	[Ignition switch ON]	0 V
54 (W)	—	Camera power supply ground	—	[Ignition switch ON]	0 V
55 (—)	—	Shield	—	—	—

A  
B  
C  
D  
E  
F  
G  
H  
I  
J  
K  
L  
M  
AV  
O  
P

# DISPLAY CONTROL UNIT

< ECU DIAGNOSIS INFORMATION >

[REAR VIEW MONITOR SYSTEM]

Terminal (Wire color)		Description		Condition	Reference value (Approx.)
+	-	Signal name	Input/ Output		
56 (BR)	36 (LG)	Composite image signal (+)	Input	[Ignition switch ON] • Image is displayed.	
58 (B)	22 (B)	Camera image signal	Input	[Ignition switch ON] • Image is displayed.	
60 (W)	—	Sound signal (-)	—	—	—
61 (B)	60 (W)	Sound signal (+)	Input	[Ignition switch ON] • Sound output	
62 (R)	42 (G)	Sound signal RH (+)	Output	[Ignition switch ON] • Sound output	
63 (—)	—	Shield	—	—	—
64 (V)	44 (L)	Sound signal LH (+)	Output	[Ignition switch ON] • Sound output	
65 (B)	45 (W)	TEL voice signal (+)	Input	[Ignition switch ON] • During voice guide output with the ☞ switch pressed	
66 (—)	—	Shield	—	—	—

# DISPLAY CONTROL UNIT

< ECU DIAGNOSIS INFORMATION >

[REAR VIEW MONITOR SYSTEM]

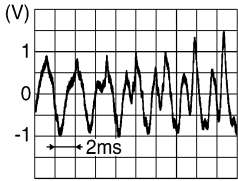
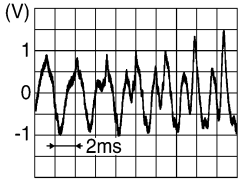
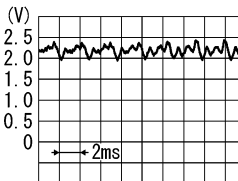
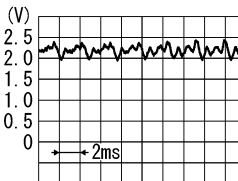
Terminal (Wire color)		Description		Condition	Reference value (Approx.)
+	-	Signal name	Input/ Output		
67 (G)	47 (R)	Voice guidance signal out- put (+)	Output	[Ignition switch ON] • Sound output	 <p style="text-align: right; font-size: small;">SKIB3609E</p>
68 (W)	48 (B)	Voice guidance signal input (+)	Input	[Ignition switch ON] • Sound output	 <p style="text-align: right; font-size: small;">SKIB3609E</p>
69 (—)	—	Shield	—	—	—
70 (G)	50 (R)	Microphone signal (NAVI)	Output	[Ignition switch ON] • Give a voice	 <p style="text-align: right; font-size: small;">PKIB5037J</p>
71 (R) <sup>*4</sup> (G) <sup>*5</sup>	52 (—)	Microphone signal	Output	[Ignition switch ON] • Give a voice	 <p style="text-align: right; font-size: small;">PKIB5037J</p>
72 (L)	22 (B)	Microphone VCC	Output	[Ignition switch ON]	5.0 V
74 (R)	54 (W)	Camera power supply	Output	[Ignition switch ON] • At rear view camera image is dis- played	6.0 V
				[Ignition switch ON] • Except for above	0 V
77 (W)	78 (B)	LVDS (+)	Input/ Output	—	—
78 (B)	—	LVDS (-)	Input/ Output	—	—
79 (—)	—	Shield	—	—	—
80 (G)	—	USB ground	—	—	—
81 (W)	—	USB V BUS signal	Output	—	—
82 (R)	—	USB D- signal	Input/ Output	—	—

A  
B  
C  
D  
E  
F  
G  
H  
I  
J  
K  
L  
M  
AV  
O  
P

# DISPLAY CONTROL UNIT

< ECU DIAGNOSIS INFORMATION >

[REAR VIEW MONITOR SYSTEM]

Terminal (Wire color)		Description		Condition	Reference value (Approx.)
+	-	Signal name	Input/ Output		
83 (L)	—	USB D+ signal	Input/ Output	—	—
84 (—)	—	Shield	—	—	—
85 (R)	—	USB V BUS signal	Output	—	—
86 (P)	—	USB D- signal	Input/ Output	—	—
87 (W)	—	USB D+ signal	Input/ Output	—	—
89 (—)	—	USB ground	—	—	—
92 (W)	—	LVDS (+)	Input/ Output	—	—
93 (B)	—	LVDS (-)	Input/ Output	—	—
94 (—)	—	Shield	—	—	—

\*1: 2.0L turbo gasoline engine models

\*2: VR30DDTT engine models

\*3: Not used

\*4: With telematics system

\*5: Without telematics system

## Fail-Safe (Display Control Unit)

INFOID:0000000013974164

If a malfunction occurs in the Infiniti InTouch, display control unit performs fail-safe activation according to the detected malfunction.

Detection item	Infiniti InTouch operation in fail-safe mode	DTC
Engine speed signal	Active noise cancellation system and active sound enhancement system function are deactivated.	B1F01
Front microphone (LH)	Active noise cancellation function is deactivated.	B1F0B B1F0C B1F0D B1F0E
Front microphone (RH)	Active noise cancellation function is deactivated.	B1F10 B1F11 B1F12 B1F13
Rear microphone	Active noise cancellation function is deactivated.	B1F15 B1F16 B1F17 B1F18
CAN communication	The system using the CAN communication signal from control unit which cannot communicate does not function.	U1000
	The system using the CAN communication signal does not function.	U1010
Display control unit	<ul style="list-style-type: none"> <li>• Display is not displayed.</li> <li>• Display control unit restart.</li> <li>• Display control unit freezes.</li> </ul> <b>NOTE:</b> Symptom other than an item may occur.	U121F

# DISPLAY CONTROL UNIT

< ECU DIAGNOSIS INFORMATION >

[REAR VIEW MONITOR SYSTEM]

Detection item	Infiniti InTouch operation in fail-safe mode	DTC	
Configuration	A function of display control unit becomes mismatched with a vehicle specification and destination.	U1223	
BOSE amp.	BOSE system does not function.	U1231	
Steering angle sensor	Predictive course line is not displayed.	U1232	
NAVI control unit	<ul style="list-style-type: none"> <li>• Map is not displayed.</li> <li>• Navigation screen does not operate.</li> </ul> <b>NOTE:</b> Symptom other than an item may occur.	U1233	
AV control unit	<ul style="list-style-type: none"> <li>• Sound is not output by a speaker.</li> <li>• CD is not played.</li> <li>• Radio does not operate.</li> </ul> <b>NOTE:</b> Symptom other than an item may occur.	U1234	
GPS antenna	The vehicle positions of a navigation screen differ.	U1244	
AV communication	AV control unit <ul style="list-style-type: none"> <li>• Sound is not output by a speaker.</li> <li>• CD is not played.</li> <li>• Radio does not operate.</li> </ul> <b>NOTE:</b> Symptom other than an item may occur.	U1249	
	BOSE amp.	Sound is not output by a speaker.	U124E
	Integral switch	<ul style="list-style-type: none"> <li>• Integral switch display is not displayed.</li> <li>• Switch operation does not operate.</li> <li>• Touch panel operation does not operate.</li> </ul> <b>NOTE:</b> Symptom other than an item may occur.	U1259
	Around view monitor control unit	Camera image is not displayed.	U125B
	Combination meter	<ul style="list-style-type: none"> <li>• Audio information is not displayed by the information display in the combination meter.</li> <li>• Navigation indicator is not displayed by the information display in the combination meter.</li> <li>• Steering switch does not operate.</li> </ul>	U1267
	Display control unit	The system of ECU which detected abnormalities does not operate.	U1300
		The system which is using AV communication does not operate.	U1310
Satellite radio antenna	Satellite radio is not received.	U1258	
USB communication	NAVI control unit	A navigation menu cannot be selected (hatching display).	U125D
	TCU	Telematics system does not function.	U1266
	External data input box	Audio equipment which connected to USB does not operate.	U12B7
Rear view camera	Rear camera image is not displayed.	U12B8	
Multifunction switch	Multifunction switch operation does not operate.	U12BA	
Radio antenna	Radio is not received.	U12BE	

A  
B  
C  
D  
E  
F  
G  
H  
I  
J  
K  
L  
M  
AV  
O  
P

# DISPLAY CONTROL UNIT

< ECU DIAGNOSIS INFORMATION >

[REAR VIEW MONITOR SYSTEM]

Detection item	Infiniti InTouch operation in fail-safe mode		DTC
Speaker/squawker/tweeter/ woofer	With BOSE system		
	Door woofer	No sound from door woofer LH or RH.	U1601 U1609
	Door squawker	No sound from door squawker LH or RH.	U1602 U160A
	Tweeter	No sound from tweeter LH or RH.	U1603 U160B
	Front squawker	No sound from front squawker LH or RH.	U1626 U162E
	Center squawker	No sound from center squawker.	U162A
	Rear squawker	No sound from rear squawker LH or RH.	U1716 U171E
	Rear woofer	No sound from rear woofer LH or RH.	U1721 U1729
	Without BOSE system		
	Door speaker	No sound from door speaker LH or RH.	U1600 U1608
	Rear speaker	No sound from rear speaker LH or RH.	U1720 U1728

## DTC Inspection Priority Chart

INFOID:000000013974165

If multiple DTCs are detected simultaneously, check them one by one depending on the following DTC inspection priority chart.

Priority	Detected items (DTC)
1	U1223: CONFIG UNFINISH
2	<ul style="list-style-type: none"> <li>• U1000: CAN COMM CIRCUIT</li> <li>• U1010: CONTROL UNIT (CAN)</li> </ul>
3	<ul style="list-style-type: none"> <li>• B1F01: ENG SPEED SIG ERROR</li> <li>• U1249: AUDIO H/U CONN</li> <li>• U124E: AMP CONN</li> <li>• U1259: 2ND DISP CONN</li> <li>• U125B: AROUND CAMERA CONN</li> <li>• U1267: METER CONN</li> </ul>

# DISPLAY CONTROL UNIT

< ECU DIAGNOSIS INFORMATION >

[REAR VIEW MONITOR SYSTEM]

Priority	Detected items (DTC)	
4	• U121F: DISPLAY CONTROL UNIT	A
	• U1233: NAVI CONTROL UNIT	
	• U1234: AV CONTROL UNIT	B
	• U1300: AV COMM CIRCUIT	
	• U1310: CONTROL UNIT(AV)	
5	• B1F0B: ANC MIC1 CIRC OPEN	C
	• B1F0C: ANC MIC1 CIRC SHORT	
	• B1F0D: ANC MIC1 CIRC SHORT-BAT	
	• B1F0E: ANC MIC1 CIRC SHORT-GND	
	• B1F10: ANC MIC2 CIRC OPEN	D
	• B1F11: ANC MIC2 CIRC SHORT	
	• B1F12: ANC MIC2 CIRC SHORT-BAT	
	• B1F13: ANC MIC2 CIRC SHORT-GND	
	• B1F15: ANC MIC3 CIRC OPEN	E
	• B1F16: ANC MIC3 CIRC SHORT	
	• B1F17: ANC MIC3 CIRC SHORT-BAT	
	• B1F18: ANC MIC3 CIRC SHORT-GND	
	• U1232: ST ANGLE SEN CALIB	F
	• U1244: GPS ANTENNA CONN	
	• U1258: XM ANTENNA CONN	
	• U125D: DVD NAVI CONN	
	• U1266: TCU CONN	G
	• U12B7: USB CONN	
	• U12B8: REAR CAMERA CONN	
	• U12BA: MULTIFUNCTION SWITCH CONN	
	• U12BE: RADIO ANTENNA CONN	H
	• U1231: AMP TEMP	
	• U1600: FL-DOOR SPEAKER	I
	• U1601: FL-DOOR WOOFER	
	• U1602: FL-DOOR SQUAWK	
	• U1603: FL-DOOR TWEETER	
	• U1608: FR-DOOR SPEAKER	J
	• U1609: FR-DOOR WOOFER	
	• U160A: FR-DOOR SQUAWK	
	• U160B: FR-DOOR TWEETER	
• U1626: F-INST L-SQUAWK	K	
• U162A: F-INST C-SQUAWK		
• U162E: F-INST R-SQUAWK		
• U1716: RL-SIDE SQUAWK	L	
• U171E: RR-SIDE SQUAWK		
• U1720: R-PSHELF L-SPEAKER		
• U1721: R-PSHELF L-WOOFER		
• U1728: R-PSHELF R-SPEAKER	M	
• U1729: R-PSHELF R-WOOFER		

## DTC Index

INFOID:000000013974166

## SELF-DIAGNOSIS RESULTS DISPLAY ITEM

AV

DTC	CONSULT display	Reference	
B1F01	ENG SPEED SIG ERROR	<a href="#">AV-295, "WITH BOSE SYSTEM: DTC Description"</a>	O
B1F0B	ANC MIC1 CIRC OPEN	<a href="#">AV-304, "DTC Description"</a>	
B1F0C	ANC MIC1 CIRC SHORT	<a href="#">AV-304, "DTC Description"</a>	P
B1F0D	ANC MIC1 CIRC SHORT-BAT	<a href="#">AV-304, "DTC Description"</a>	
B1F0E	ANC MIC1 CIRC SHORT-GND	<a href="#">AV-304, "DTC Description"</a>	
B1F10	ANC MIC2 CIRC OPEN	<a href="#">AV-309, "DTC Description"</a>	
B1F11	ANC MIC2 CIRC SHORT	<a href="#">AV-309, "DTC Description"</a>	
B1F12	ANC MIC2 CIRC SHORT-BAT	<a href="#">AV-309, "DTC Description"</a>	

# DISPLAY CONTROL UNIT

< ECU DIAGNOSIS INFORMATION >

[REAR VIEW MONITOR SYSTEM]

DTC	CONSULT display	Reference	
B1F13	ANC MIC2 CIRC SHORT-GND	<a href="#">AV-309, "DTC Description"</a>	
B1F15	ANC MIC3 CIRC OPEN	<a href="#">AV-314, "DTC Description"</a>	
B1F16	ANC MIC3 CIRC SHORT	<a href="#">AV-314, "DTC Description"</a>	
B1F17	ANC MIC3 CIRC SHORT-BAT	<a href="#">AV-314, "DTC Description"</a>	
B1F18	ANC MIC3 CIRC SHORT-GND	<a href="#">AV-314, "DTC Description"</a>	
U1000	CAN COMM CIRCUIT	<a href="#">AV-327, "DISPLAY CONTROL UNIT : DTC Description"</a>	
U1010	CONTROL UNIT (CAN)	<a href="#">AV-330, "DISPLAY CONTROL UNIT : DTC Description"</a>	
U121F	DISPLAY CONTROL UNIT	<a href="#">AV-332, "DTC Description"</a>	
U1223	CONFIG UNFINISH	<a href="#">AV-333, "DTC Description"</a>	
U1231	AMP TEMP	<a href="#">AV-334, "DTC Description"</a>	
U1232	ST ANGLE SEN CALIB	<a href="#">AV-335, "DTC Description"</a>	
U1233	NAVI CONTROL UNIT	<a href="#">AV-336, "DTC Description"</a>	
U1234	AV CONTROL UNIT	<a href="#">AV-337, "DTC Description"</a>	
U1244	GPS ANTENNA CONN	<a href="#">AV-338, "DTC Description"</a>	
U1249	AUDIO H/U CONN	<a href="#">AV-339, "DTC Description"</a>	
U124E	AMP CONN	<a href="#">AV-341, "DTC Description"</a>	
U1258	XM ANTENNA CONN	GND-SHORT	<a href="#">AV-343, "DTC Description"</a>
		OPEN	
U1259	2ND DISP CONN	<a href="#">AV-345, "DTC Description"</a>	
U125B	AROUND CAMERA CONN	<a href="#">AV-347, "DTC Description"</a>	
U125D	DVD NAVI CONN	<a href="#">AV-349, "DTC Description"</a>	
U1266	TCU CONN	<a href="#">AV-350, "DTC Description"</a>	
U1267	METER CONN	<a href="#">AV-352, "DTC Description"</a>	
U12B7	USB CONN	<a href="#">AV-354, "DTC Description"</a>	
U12B8	REAR CAMERA CONN	<a href="#">AV-355, "DTC Description"</a>	
U12BA	MULTIFUNCTION SWITCH CONN	<a href="#">AV-357, "DTC Description"</a>	
U12BE	RADIO ANTENA CONN	GND-SHORT	<a href="#">AV-359, "DTC Description"</a>
		OPEN	
U1300	AV COMM CIRCUIT	<a href="#">AV-361, "DTC Description"</a>	
U1310	CONTROL UNIT(AV)	<a href="#">AV-363, "DTC Description"</a>	
U1600	FL-DOOR SPEAKER	OPEN	<a href="#">AV-364, "DTC Description"</a>
		SHORT	
		GND-SHORT	
		VB-SHORT	
U1601	FL-DOOR WOOFER	OPEN	<a href="#">AV-367, "DTC Description"</a>
		SHORT	
		GND-SHORT	
		VB-SHORT	
U1602	FL-DOOR SQUAWK	OPEN	<a href="#">AV-370, "DTC Description"</a>
		SHORT	
		GND-SHORT	
		VB-SHORT	

# DISPLAY CONTROL UNIT

< ECU DIAGNOSIS INFORMATION >

[REAR VIEW MONITOR SYSTEM]

DTC	CONSULT display	Reference				
U1603	FL-DOOR TWEETER	OPEN	<a href="#">AV-373, "DTC Description"</a>	A		
		SHORT		<a href="#">AV-373, "DTC Description"</a>	<a href="#">AV-373, "DTC Description"</a>	
		GND-SHORT				B
		VB-SHORT				C
U1608	FR-DOOR SPEAKER	OPEN	<a href="#">AV-364, "DTC Description"</a>			D
		SHORT		<a href="#">AV-364, "DTC Description"</a>	E	
		GND-SHORT			<a href="#">AV-364, "DTC Description"</a>	F
		VB-SHORT				G
U1609	FR-DOOR WOOFER	OPEN	<a href="#">AV-367, "DTC Description"</a>			H
		SHORT		<a href="#">AV-367, "DTC Description"</a>		I
		GND-SHORT			<a href="#">AV-367, "DTC Description"</a>	J
		VB-SHORT				K
U160A	FR-DOOR SQUAWK	OPEN	<a href="#">AV-370, "DTC Description"</a>			L
		SHORT		<a href="#">AV-370, "DTC Description"</a>		M
		GND-SHORT			<a href="#">AV-370, "DTC Description"</a>	N
		VB-SHORT				O
U160B	FR-DOOR TWEETER	OPEN	<a href="#">AV-373, "DTC Description"</a>			P
		SHORT		<a href="#">AV-373, "DTC Description"</a>		Q
		GND-SHORT			<a href="#">AV-373, "DTC Description"</a>	R
		VB-SHORT				S
U1626	F-INST L-SQUAWK	OPEN	<a href="#">AV-376, "DTC Description"</a>			T
		SHORT		<a href="#">AV-376, "DTC Description"</a>		U
		GND-SHORT			<a href="#">AV-376, "DTC Description"</a>	V
		VB-SHORT				W
U162A	F-INST C-SQUAWK	OPEN	<a href="#">AV-379, "DTC Description"</a>			X
		SHORT		<a href="#">AV-379, "DTC Description"</a>		Y
		GND-SHORT			<a href="#">AV-379, "DTC Description"</a>	Z
		VB-SHORT				AA
U162E	F-INST R-SQUAWK	OPEN	<a href="#">AV-376, "DTC Description"</a>			AB
		SHORT		<a href="#">AV-376, "DTC Description"</a>		AC
		GND-SHORT			<a href="#">AV-376, "DTC Description"</a>	AD
		VB-SHORT				AE
U1716	RL-SIDE SQUAWK	OPEN	<a href="#">AV-381, "DTC Description"</a>			AF
		SHORT		<a href="#">AV-381, "DTC Description"</a>		AG
		GND-SHORT			<a href="#">AV-381, "DTC Description"</a>	AH
		VB-SHORT				AI
U171E	RR-SIDE SQUAWK	OPEN	<a href="#">AV-381, "DTC Description"</a>			AJ
		SHORT		<a href="#">AV-381, "DTC Description"</a>		AK
		GND-SHORT			<a href="#">AV-381, "DTC Description"</a>	AL
		VB-SHORT				AM
U1720	R-PSHELF L-SPEAKER	OPEN	<a href="#">AV-384, "DTC Description"</a>			AN
		SHORT		<a href="#">AV-384, "DTC Description"</a>		AO
		GND-SHORT			<a href="#">AV-384, "DTC Description"</a>	AP
		VB-SHORT				AQ

# DISPLAY CONTROL UNIT

< ECU DIAGNOSIS INFORMATION >

[REAR VIEW MONITOR SYSTEM]

DTC	CONSULT display		Reference
U1721	R-PSHELF L-WOOFER	OPEN	<a href="#">AV-387, "DTC Description"</a>
		SHORT	
		GND-SHORT	
		VB-SHORT	
U1728	R-PSHELF R-SPEAKER	OPEN	<a href="#">AV-384, "DTC Description"</a>
		SHORT	
		GND-SHORT	
		VB-SHORT	
U1729	R-PSHELF R-WOOFER	OPEN	<a href="#">AV-387, "DTC Description"</a>
		SHORT	
		GND-SHORT	
		VB-SHORT	

# REAR VIEW MONITOR SYSTEM

[REAR VIEW MONITOR SYSTEM]

< WIRING DIAGRAM >

## WIRING DIAGRAM

### REAR VIEW MONITOR SYSTEM

#### Wiring Diagram

INFOID:000000013717628

#### 2.0L TURBO GASOLINE ENGINE

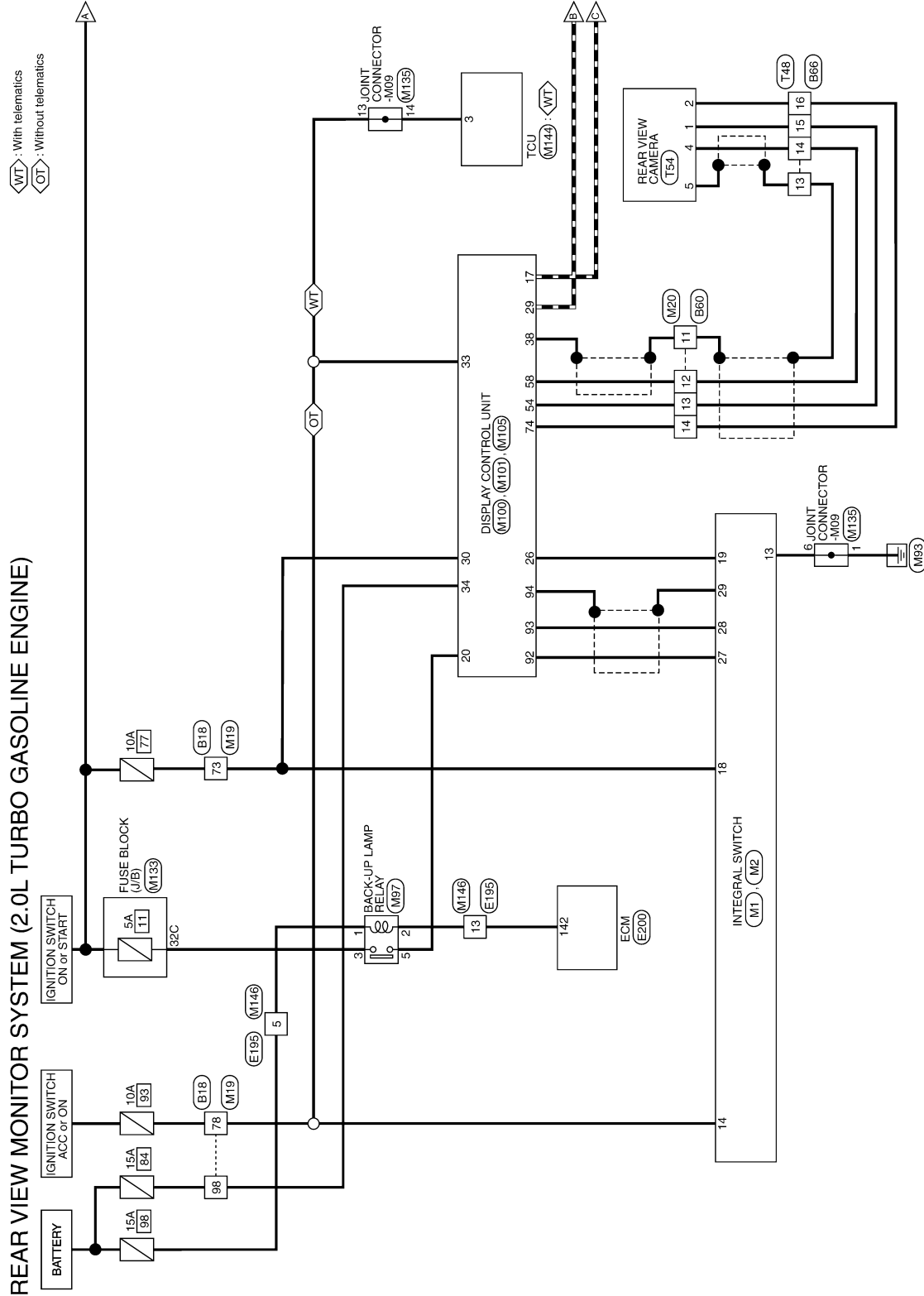

2016/04/07

JRNWF7502GB

A  
B  
C  
D  
E  
F  
G  
H  
I  
J  
K  
L  
M  
N  
O  
P

AV

# REAR VIEW MONITOR SYSTEM

[REAR VIEW MONITOR SYSTEM]

< WIRING DIAGRAM >

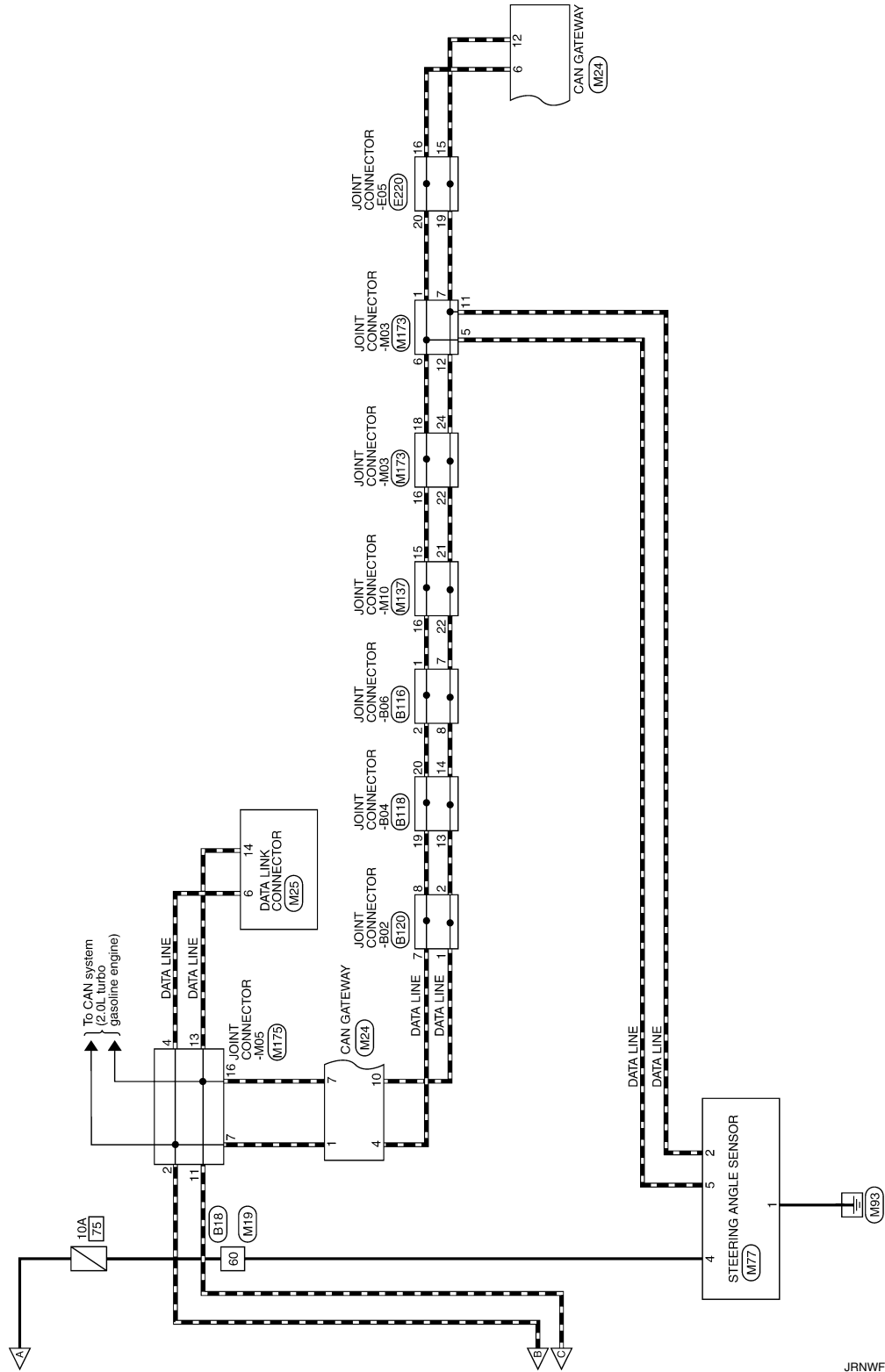

JRNWF7503GB

# REAR VIEW MONITOR SYSTEM

## [REAR VIEW MONITOR SYSTEM]

< WIRING DIAGRAM >

### REAR VIEW MONITOR SYSTEM (2.0L TURBO GASOLINE ENGINE)

Connector No.	B18
Connector Name	WIRE TO WIRE
Connector Type	TH80FW-CS16-TM4



Terminal No.	Color Of Wire	Signal Name (Specification)
1	Y	-
2	G	-
3	L	-
5	Y	-
7	V	-
10	BG	-
11	BG	-
12	LG	-
13	GR	-
14	R	-
15	L	-
16	V	-
18	W	-
19	BR	-
20	W	-
22	R	-
23	V	-
24	R	- [With 2.0L turbo gasoline engine]
24	V	- [With VR30 engine]
25	V	- [With 2.0L turbo gasoline engine]
25	W	- [With VR30 engine]
26	G	-
27	R	-
28	R	-
31	B	- [With VR30 engine]
31	BR	- [With 2.0L turbo gasoline engine]
32	B	-
33	B	-
34	LG	-
35	P	-
36	W	-
37	SB	-
38	LG	-
40	P	-
41	SB	-

42	BR	-
43	BG	-
44	BG	-
46	R	-
50	W	-
51	SB	-
52	V	-
53	LG	-
54	R	-
55	R	-
58	V	-
59	GR	-
60	G	-
61	G	-
62	BG	-
63	BR	-
64	Y	-
66	R	-
70	R	-
71	W	-
72	B	-
73	W	-
74	L	-
75	R	-
76	BR	-
77	B	-
78	SB	-
79	W	-
81	B	-
82	R	-
83	BG	-
84	L	-
85	R	-
86	B	-
88	G	-
89	V	-
91	GR	-
92	GR	-
93	GR	-
94	GR	-
96	Y	-
98	BR	- [With VR30 engine and with BOSE system]
98	Y	- [Except with VR30 engine and with BOSE system]

Connector No.	B60
Connector Name	WIRE TO WIRE
Connector Type	TH16FW-AH

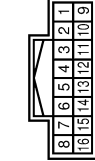

Terminal No.	Color Of Wire	Signal Name (Specification)
7	R	-
8	L	-
10	Y	-
11	SHIELD	-
12	B	-
13	W	-
14	R	-

Connector No.	B66
Connector Name	WIRE TO WIRE
Connector Type	NS16MW-C5

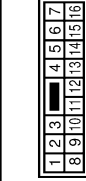

Terminal No.	Color Of Wire	Signal Name (Specification)
1	R	-
2	BG	-
4	SHIELD	-
5	W	-
6	GR	-
8	B	-
9	R	-
10	P	-
11	B	-
13	SHIELD	- [With rear view monitor]
13	W	- [With around view monitor]
14	B	- [With rear view monitor]

14	G	- [With around view monitor]
15	R	- [With around view monitor]
15	W	- [With rear view monitor]
16	B	- [With around view monitor]
16	R	- [With rear view monitor]

Connector No.	B116
Connector Name	JOINT CONNECTOR-B06
Connector Type	Z4342_4G32A



Terminal No.	Color Of Wire	Signal Name (Specification)
1	L	-
2	L	-
3	L	-
4	L	-
5	L	-
6	L	-
7	R	-
8	R	- [With Gateway]
8	V	- [Without Gateway]
9	R	- [With Gateway]
9	V	- [Without Gateway]
10	V	-
11	V	-
12	P	- [With 2.0L turbo gasoline engine]
12	R	- [With VR30 engine]
13	SHIELD	-
14	SHIELD	-
15	SHIELD	-
16	SHIELD	-
17	SHIELD	-
18	SHIELD	-
19	L	-
20	L	-
21	L	-
22	R	-
23	R	-
24	R	-

A  
B  
C  
D  
E  
F  
G  
H  
I  
J  
K  
L  
M  
AV  
O  
P

# REAR VIEW MONITOR SYSTEM

[REAR VIEW MONITOR SYSTEM]

< WIRING DIAGRAM >

## REAR VIEW MONITOR SYSTEM (2.0L TURBO GASOLINE ENGINE)

Connector No.	B118
Connector Name	JOINT CONNECTOR-B04
Connector Type	24342_4GAZA



6	5	4	3	2	1
12	11	10	9	8	7
18	17	16	15	14	13
24	23	22	21	20	19

Connector No.	B120
Connector Name	JOINT CONNECTOR-B02
Connector Type	24342_4GAZA



6	5	4	3	2	1
12	11	10	9	8	7
18	17	16	15	14	13
24	23	22	21	20	19

Terminal No.	Color Of Wire	Signal Name [Specification]
1	R	-
2	R	-
3	R	- [With VR30 engine]
3	R	- [With 2.0L turbo gasoline engine]
4	L	- [With VR30 engine]
4	L	- [With 2.0L turbo gasoline engine]
5	L	- [With 2.0L turbo gasoline engine]
6	R	-
7	L	-
8	L	-
9	LG	- [With 2.0L turbo gasoline engine]
9	LG	- [With VR30 engine]
10	LG	- [With 2.0L turbo gasoline engine]
10	LG	- [With VR30 engine]
11	LG	- [With 2.0L turbo gasoline engine]
11	LG	- [With VR30 engine]
12	LG	- [With 2.0L turbo gasoline engine]
12	LG	- [With VR30 engine]
13	L	-
13	L	- [With 2.0L turbo gasoline engine]
13	L	- [With VR30 engine]
14	L	-
14	R	- [With 2.0L turbo gasoline engine]
14	R	- [With VR30 engine]
15	R	-
15	R	- [With 2.0L turbo gasoline engine]
15	R	- [With VR30 engine]
16	L	-
17	L	-
18	L	-
18	L	- [With 2.0L turbo gasoline engine]
18	L	- [With VR30 engine]
19	SHIELD	-
20	SHIELD	-

24	W	-
----	---	---

Connector No.	E195
Connector Name	WIRE TO WIRE
Connector Type	TK36FW-NS10



1	2	3	4	5	6
7	8	9	10	11	12
13	14	15	16	17	18
19	20	21	22	23	24

Terminal No.	Color Of Wire	Signal Name [Specification]
5	BR	-
8	GR	-
9	P	-
10	R	-
11	L	-
12	P	-
13	GR	-
14	Y	-
15	G	-
16	W	-
17	L	-
18	R	-
19	BR	-
20	SHIELD	-
21	BR	-
22	V	-
23	W	-
24	L	-
25	G	-
26	G	-
30	Y	-
31	GR	-
32	SB	-
33	W	-
34	W	-
35	B	-
36	G	-
37	SHIELD	-
38	R	-
39	L	-
40	GR	-
41	W	-
42	B	-

43	BR	-
44	P	-
45	SB	-
46	Y	-

Connector No.	E200
Connector Name	ECM
Connector Type	ADAS21E-AN2E



1	2	3	4	5	6
7	8	9	10	11	12
13	14	15	16	17	18
19	20	21	22	23	24

Terminal No.	Color Of Wire	Signal Name [Specification]
97	G	POWER SUPPLY (MAIN)
98	B	ECM GROUND
99	G	POWER SUPPLY (MAIN)
100	B	ECM GROUND
101	G	POWER SUPPLY (MAIN)
102	B	ECM GROUND
103	V	COOLING FAN CONTROL SIGNAL (PWM)
104	Y	SENSOR POWER SUPPLY
105	R	SENSOR POWER SUPPLY
106	W	SENSOR GROUND
109	P	ENGINE SPEED SIGNAL
111	G	POWER SUPPLY
116	LG	STARTER RELAY-L
119	BR	SENSOR GROUND
120	BG	SENSOR GROUND
123	BR	MAIN RELAY CONTROL SIGNAL
127	V	FUEL PUMP ON SIGNAL
132	G	ACCELERATOR PEDAL POSITION SENSOR 1 CAN-H
137	L	CAN-H
138	L	DRIVETRAIN CAN-H
142	GR	BACK-UP LAMP SWITCH
143	LG	REFRIGERANT PRESSURE SENSOR
145	L	ACCELERATOR PEDAL POSITION SENSOR 2
146	L	FUEL TANK PRESSURE SENSOR
148	L	THROTTLE CONTROL MOTOR (CLOSE) (BANK 2) CAN-L
150	P	DRIVETRAIN CAN-L
151	P	EVAP CANISTER VENT CONTROL VALVE
152	B	EVAP PURGE CONTROL VALVE
153	G	-

# REAR VIEW MONITOR SYSTEM

[REAR VIEW MONITOR SYSTEM]

< WIRING DIAGRAM >

## REAR VIEW MONITOR SYSTEM (2.0L TURBO GASOLINE ENGINE)

Connector No.	E220
Connector Name	JOINT CONNECTOR-E05
Connector Type	NH24FEJ



Terminal No.	Color Of Wire	Signal Name [Specification]
3	W	-
4	L	-
7	W	-
8	L	-
15	R	-
16	L	-
19	R	-
20	L	-
23	R	-
24	L	-

Connector No.	M1
Connector Name	INTEGRAL SWITCH
Connector Type	TH24FW-NH



Terminal No.	Color Of Wire	Signal Name [Specification]
2	R	ILLUMINATION SIGNAL
3	LG	AV COMMUNICATION SIGNAL (L)
4	SB	AV COMMUNICATION SIGNAL (H)
7	W/B	DISK EJECT SIGNAL
8	G	HAZARD SIGNAL
13	B	GROUND
14	SB	ACC POWER SUPPLY [With 2.0L turbo gasoline engine]
14	V	ACC POWER SUPPLY [With VR30 engine]
15	B	ILLUMINATION CONTROL SIGNAL
16	BG	DISK EJECT SIGNAL GROUND

18	R	IGNITION SIGNAL [With VR30 engine]
18	W	IGNITION SIGNAL [With 2.0L turbo gasoline engine]
19	BR	CAMERA SWITCH SIGNAL

Connector No.	M2
Connector Name	INTEGRAL SWITCH
Connector Type	TyCo_1554987-6



Terminal No.	Color Of Wire	Signal Name [Specification]
27	W	LVDS (+)
28	B	LVDS (-)
29	SHIELD	SHIELD

Connector No.	M19
Connector Name	WIRE TO WIRE
Connector Type	TH80MW-CS16-TM4



Terminal No.	Color Of Wire	Signal Name [Specification]
1	Y	-
2	G	-
3	SB	-
5	Y	-
7	W	-
10	BG	-
11	BR	-
12	LG	-
13	GR	-
14	R	-
15	L	-
16	V	-

18	W	-
19	BR	-
20	W	-
24	R	- [With 2.0L turbo gasoline engine]
24	Y	- [With VR30 engine]
25	P	- [With 2.0L turbo gasoline engine]
25	W	- [With VR30 engine]
26	G	-
27	R	-
28	R	-
31	BR	-
32	B	-
33	B	-
34	V	-
35	P	-
36	W	-
37	SB	-
38	LG	-
40	P	-
41	G	-
42	BR	-
43	BR	-
44	BR	-
46	BG	-
50	W	-
51	Y	-
52	V	-
53	LG	-
54	R	-
55	R	-
58	V	-
59	BG	-
60	G	-
61	G	-
62	BG	-
63	BR	-
64	V	-
66	R	-
70	LG	-
71	W	-
72	B	-
73	W	-
74	L	-
75	W	-
76	BR	-
77	B	-
78	SB	-
79	W	-
81	B	-
82	R	-

83	BG	-
84	L	-
85	W	-
86	B	-
88	G	-
89	V	-
91	GR	-
93	GR	-
94	GR	-
96	W	-
98	BR	- [With VR30 engine and with BOSE system]
98	Y	- [Except with VR30 engine and with BOSE system]

Connector No.	M20
Connector Name	WIRE TO WIRE
Connector Type	TH16MMV-NH



Terminal No.	Color Of Wire	Signal Name [Specification]
7	W	-
8	L	-
10	Y	-
11	SHIELD	-
12	B	-
13	W	-
14	R	-

A  
B  
C  
D  
E  
F  
G  
H  
I  
J  
K  
L  
M  
N  
O  
P

AV

# REAR VIEW MONITOR SYSTEM

< WIRING DIAGRAM >

[REAR VIEW MONITOR SYSTEM]

## REAR VIEW MONITOR SYSTEM (2.0L TURBO GASOLINE ENGINE)

Connector No.	M24
Connector Name	CAN GATEWAY
Connector Type	TH12FW-AH

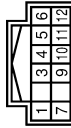

Terminal No.	Color Of Wire	Signal Name [Specification]
1	L	CAN-H (CAN COMMUNICATION CIRCUIT 1)
3	W	BATTERY POWER SUPPLY
4	L	CAN-H (CAN COMMUNICATION CIRCUIT 2)
5	B	GROUND
6	L	CAN-H (CAN COMMUNICATION CIRCUIT 2)
7	P	CAN-H (CAN COMMUNICATION CIRCUIT 1)
9	R	IGNITION POWER SUPPLY (With VRS30 engine)
9	W	IGNITION POWER SUPPLY (With 2.0L turbo gasoline engine)
10	R	CAN-L (CAN COMMUNICATION CIRCUIT 2)
11	B	GROUND
12	R	CAN-L (CAN COMMUNICATION CIRCUIT 2)

Connector No.	M25
Connector Name	DATA LINK CONNECTOR
Connector Type	BD16FW



Terminal No.	Color Of Wire	Signal Name [Specification]
3	LG	M_CAN_L
4	B	EARTH
5	B	EARTH
6	L	CAN-H
7	V	KLIME (With 2.0L turbo gasoline engine)
8	W	IGN_SW
11	SB	M_CAN_H
12	R	CAN-L

Connector No.	M77
Connector Name	STEERING ANGLE SENSOR
Connector Type	TH08FW-AH



Terminal No.	Color Of Wire	Signal Name [Specification]
1	B	GROUND
2	P	CAN-L (Without Gateway)
2	R	CAN-L (With Gateway)
4	G	IGN
5	L	CAN-H

Connector No.	M97
Connector Name	BACK-UP LAMP RELAY
Connector Type	MS02FL-M2-LC



Terminal No.	Color Of Wire	Signal Name [Specification]
1	R	-
2	SB	- (With 2.0L turbo gasoline engine)
2	W	- (With VRS30 engine)
3	R	-
5	BR	-

Connector No.	M100
Connector Name	DISPLAY CONTROL UNIT
Connector Type	TH24FW-AH

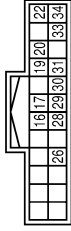

Terminal No.	Color Of Wire	Signal Name [Specification]
16	LG	AV COMMUNICATION SIGNAL (L)
17	P	CAN-L
19	R	DIMMER SIGNAL
20	BR	REVERSE SIGNAL
22	B	GROUND
26	BR	CAMERA SWITCH SIGNAL
28	SB	AV COMMUNICATION SIGNAL (H)
29	L	CAN-H
30	R	IGNITION SIGNAL (With VRS30 engine)
30	W	IGNITION SIGNAL (With 2.0L turbo gasoline engine)
31	R	VEHICLE SPEED SIGNAL (8-PULSE)
33	SB	ACC POWER SUPPLY
34	Y	BATTERY POWER SUPPLY

Connector No.	M101
Connector Name	DISPLAY CONTROL UNIT
Connector Type	TH40FW-AH



Terminal No.	Color Of Wire	Signal Name [Specification]
36	LG	COMPOSITE IMAGE SIGNAL (-)
38	SHIELD	SHIELD
40	SHIELD	MANUFACTURER SPECIFIC SIGNAL
42	G	SOUND SIGNAL RH (-)
43	SHIELD	SHIELD
44	L	SOUND SIGNAL LH (-)
45	W	TEL VOICE SIGNAL (-)

46	SHIELD	SHIELD
47	R	VOICE GUIDANCE SIGNAL OUTPUT (-)
48	B	VOICE GUIDANCE SIGNAL INPUT (-)
49	W	NS ON/OFF SIGNAL
50	R	MICROPHONE SIGNAL GROUND (WITH NAVIGATION)
51	SHIELD	SHIELD
52	SHIELD	MICROPHONE SIGNAL GROUND
54	W	CAMERA POWER SUPPLY GROUND
55	SHIELD	SHIELD
56	BR	COMPOSITE IMAGE SIGNAL (-)
58	B	CAMERA IMAGE SIGNAL
60	W	SOUND SIGNAL (-)
61	B	SOUND SIGNAL (+)
62	R	SOUND SIGNAL RH (+)
63	SHIELD	SHIELD
64	V	SOUND SIGNAL LH (+)
65	B	TEL VOICE SIGNAL (+)
66	SHIELD	SHIELD
67	G	VOICE GUIDANCE SIGNAL OUTPUT (-)
68	W	VOICE GUIDANCE SIGNAL INPUT (+)
69	SHIELD	SHIELD
70	G	MICROPHONE SIGNAL (NAV)
71	G	MICROPHONE SIGNAL (Without telematics system)
71	R	MICROPHONE SIGNAL (With telematics system)
72	L	MICROPHONE VCC
74	R	CAMERA POWER SUPPLY

Connector No.	M105
Connector Name	DISPLAY CONTROL UNIT
Connector Type	1ycv_1554987-6



Terminal No.	Color Of Wire	Signal Name [Specification]
92	W	LVD5 (+)
93	B	LVD5 (-)
94	SHIELD	SHIELD

# REAR VIEW MONITOR SYSTEM

## [REAR VIEW MONITOR SYSTEM]

< WIRING DIAGRAM >

### REAR VIEW MONITOR SYSTEM (2.0L TURBO GASOLINE ENGINE)

Connector No.	M133
Connector Name	FUSE BLOCK (J/B)
Connector Type	TH40FW-AH

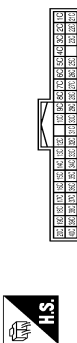

Connector No.	M135
Connector Name	JOINT CONNECTOR-M09
Connector Type	24342_4G2A

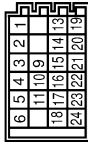

Terminal No.	Color Of Wire	Signal Name [Specification]
1	B	-
2	B	-
3	B	-
4	B	-
5	B	-
6	B	-
9	LG	-
10	LG	-
11	LG	-
13	B	- [With VR30 engine]
13	SB	- [With 2.0L turbo gasoline engine]
14	B	- [With VR30 engine]
14	SB	- [With 2.0L turbo gasoline engine]
15	B	- [With VR30 engine]
15	SB	- [With 2.0L turbo gasoline engine]
16	SB	- [With 2.0L turbo gasoline engine]
16	Y	- [With VR30 engine]
17	SB	- [With 2.0L turbo gasoline engine]
17	Y	- [With VR30 engine]
18	SB	- [With 2.0L turbo gasoline engine]
18	Y	- [With VR30 engine]
19	SHIELD	- [With VR30 engine]
20	R	-
21	R	-
22	SHIELD	-
23	L	-
24	L	-

Connector No.	M137
Connector Name	JOINT CONNECTOR-M10
Connector Type	24342_4G2A



Terminal No.	Color Of Wire	Signal Name [Specification]
1	B	-
2	B	-
3	B	-
4	B	-
5	B	-
7	B	-
8	B	-
9	B	-
10	B	-
11	B	-
13	L	-
15	L	-
16	L	-
19	R	-
21	R	-
22	R	-

Connector No.	M144
Connector Name	TCU
Connector Type	TH40FB-AH



Terminal No.	Color Of Wire	Signal Name [Specification]
1	Y	BATTERY POWER SUPPLY
2	SB	ACC POWER SUPPLY [With 2.0L turbo gasoline engine]
2	V	ACC POWER SUPPLY [With VR30 engine]
3	SB	ACC OUTPUT

5	BR	SOS SWITCH LED SIGNAL
6	L	CAN-H
7	P	CAN-L
10	R	IGNITION SIGNAL [With VR30 engine]
10	W	IGNITION SIGNAL [With 2.0L turbo gasoline engine]
11	SHIELD	MICROPHONE SIGNAL GROUND
12	R	MICROPHONE SIGNAL
15	SHIELD	SHIELD
17	G	MICROPHONE SIGNAL
17	G	MICROPHONE YCC
26	SB	AV COMMUNICATION SIGNAL (H)
27	LG	AV COMMUNICATION SIGNAL (L)
28	B	GROUND
29	B	GROUND
30	SHIELD	SHIELD
31	B	SOUND SIGNAL (H)
32	W	SOUND SIGNAL (L)
37	G	SOS CALL SWITCH SIGNAL

Connector No.	M146
Connector Name	WIRE TO WIRE
Connector Type	TK36MW-N510



Terminal No.	Color Of Wire	Signal Name [Specification]
5	R	-
8	GR	-
9	V	-
10	BG	-
11	L	-
12	P	-
13	SB	-
14	Y	-
15	G	-
16	BR	-
17	W	-
18	R	-
19	L	-
20	SHIELD	-
21	BR	-
22	B	-

A  
B  
C  
D  
E  
F  
G  
H  
I  
J  
K  
L  
M  
N  
O  
P

AV

# REAR VIEW MONITOR SYSTEM

[REAR VIEW MONITOR SYSTEM]

< WIRING DIAGRAM >

## REAR VIEW MONITOR SYSTEM (2.0L TURBO GASOLINE ENGINE)

23	G	-	-	-	-
24	L	-	-	-	-
25	R	-	-	-	-
26	G	-	-	-	-
28	L	-	-	-	- [With 2.0L turbo gasoline engine]
29	P	-	-	-	- [With VR30 engine]
30	Y	-	-	-	- [With 2.0L turbo gasoline engine]
31	GR	-	-	-	- [With VR30 engine]
32	SB	-	-	-	- [With 2.0L turbo gasoline engine]
33	BG	-	-	-	- [With VR30 engine]
34	W	-	-	-	- [With VR30 engine]
35	G	-	-	-	- [With 2.0L turbo gasoline engine]
36	R	-	-	-	- [With VR30 engine]
37	SHIELD	-	-	-	- [With 2.0L turbo gasoline engine]
38	B	-	-	-	- [With VR30 engine]
39	W	-	-	-	- [With 2.0L turbo gasoline engine]
40	B	-	-	-	- [With 2.0L turbo gasoline engine]
41	GR	-	-	-	- [With VR30 engine]
42	B	-	-	-	- [With 2.0L turbo gasoline engine]
43	LG	-	-	-	- [With VR30 engine]
44	B	-	-	-	- [With 2.0L turbo gasoline engine]
45	SB	-	-	-	- [With VR30 engine]
46	B	-	-	-	- [With VR30 engine]

Connector No.	M173
Connector Name	JOINT CONNECTOR-M03
Connector Type	24342_4GAZA

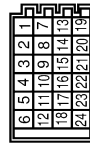

Terminal No.	Color Of Wire	Signal Name [Specification]
1	L	-
2	L	-
3	L	-
4	L	-
5	L	-
6	L	-
7	R	-
8	R	-
9	R	-
10	R	-
11	R	-

12	R	-	-	-	-
13	SB	-	-	-	-
14	SB	-	-	-	-
15	SB	-	-	-	-
16	L	-	-	-	- [With 2.0L turbo gasoline engine]
16	SB	-	-	-	- [With VR30 engine]
17	L	-	-	-	- [With 2.0L turbo gasoline engine]
17	SB	-	-	-	- [With VR30 engine]
18	L	-	-	-	- [With 2.0L turbo gasoline engine]
18	SB	-	-	-	- [With VR30 engine]
19	RG	-	-	-	- [With VR30 engine]
19	LG	-	-	-	- [With 2.0L turbo gasoline engine]
20	BR	-	-	-	- [With VR30 engine]
20	LG	-	-	-	- [With 2.0L turbo gasoline engine]
21	BR	-	-	-	- [With VR30 engine]
21	LG	-	-	-	- [With 2.0L turbo gasoline engine]
22	R	-	-	-	- [With 2.0L turbo gasoline engine]
22	SB	-	-	-	- [With VR30 engine]
23	R	-	-	-	- [With 2.0L turbo gasoline engine]
23	SB	-	-	-	- [With VR30 engine]
24	R	-	-	-	- [With 2.0L turbo gasoline engine]
24	SB	-	-	-	- [With VR30 engine]

Connector No.	M175
Connector Name	JOINT CONNECTOR-M05
Connector Type	NH20F-DC



Terminal No.	Color Of Wire	Signal Name [Specification]
1	L	-
2	L	-
3	L	-
4	L	-
5	L	-
6	L	-
7	L	-
8	L	-
10	P	-
11	P	-
12	P	-
13	P	-

14	P	-	-	-	-
15	P	-	-	-	-
16	P	-	-	-	-
17	P	-	-	-	-
19	W	-	-	-	-
20	W	-	-	-	-

Connector No.	T48
Connector Name	WIRE TO WIRE
Connector Type	NS16FW-CS



Terminal No.	Color Of Wire	Signal Name [Specification]
1	Y	-
2	BG	-
4	L	-
5	P	-
6	G	-
8	B	-
9	R	-
10	P	-
11	L	-
13	G	- [With around view monitor]
13	L	- [With rear view monitor]
14	B	- [With around view monitor]
14	R	- [With around view monitor]
15	B	- [With around view monitor]
15	W	- [With rear view monitor]
16	R	- [With rear view monitor]
16	W	- [With around view monitor]

Connector No.	T54
Connector Name	REAR VIEW CAMERA
Connector Type	RH06FB-1V



Terminal No.	Color Of Wire	Signal Name [Specification]
1	W	GND
2	R	CAMERA_ON
4	B	COMP+
5	L	COMP-

# REAR VIEW MONITOR SYSTEM

[REAR VIEW MONITOR SYSTEM]

< WIRING DIAGRAM >

VR ENGINE

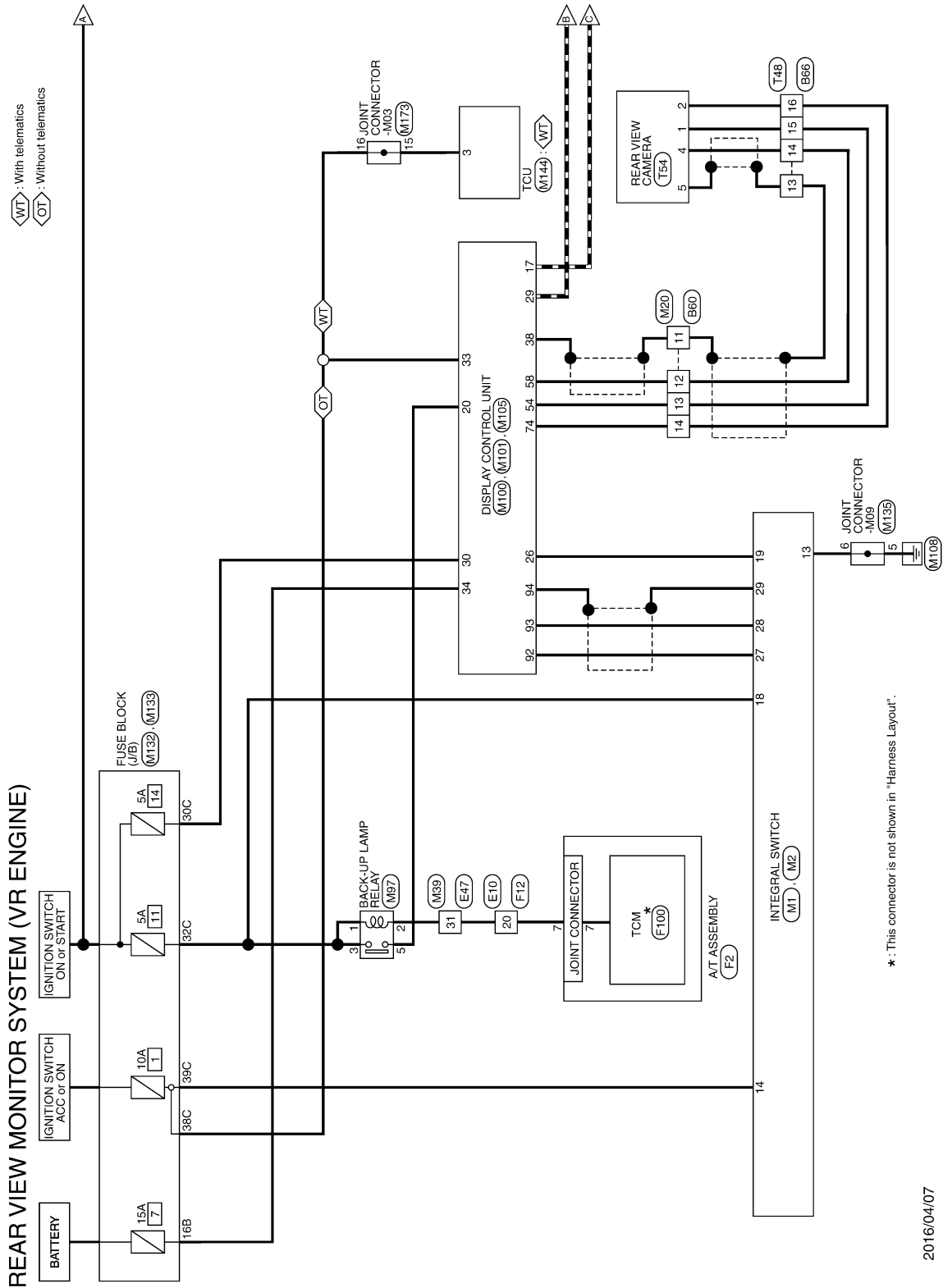

\* : This connector is not shown in "Harness Layout".

2016/04/07

JRNWF7495GB

A  
B  
C  
D  
E  
F  
G  
H  
I  
J  
K  
L  
M  
N  
O  
P

AV

# REAR VIEW MONITOR SYSTEM

< WIRING DIAGRAM >

[REAR VIEW MONITOR SYSTEM]

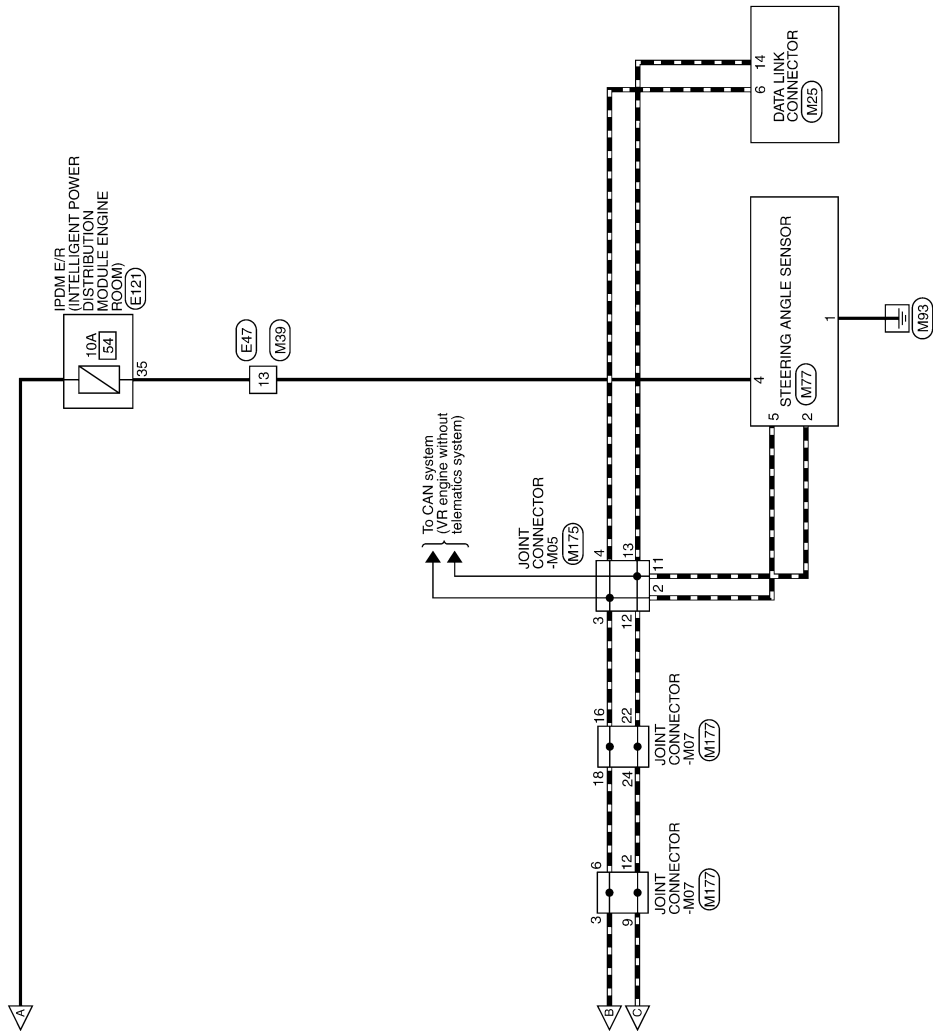

JRNWF7496GB



# REAR VIEW MONITOR SYSTEM

< WIRING DIAGRAM >

[REAR VIEW MONITOR SYSTEM]

## REAR VIEW MONITOR SYSTEM (VR ENGINE)

34	Y	-
35	G	-
36	SB	- [With VR30 engine]
36	W	- [With 2.0L turbo gasoline engine]
37	GR	-
38	BR	-
41	GR	-
43	V	-
44	G	- [With 2.0L turbo gasoline engine]
44	GR	- [With VR30 engine]
46	R	- [With VR30 engine]
46	Y	- [With 2.0L turbo gasoline engine]

Connector No.	F2
Connector Name	A/T ASSEMBLY
Connector Type	IRKDFG-DGY



Terminal No.	Color Of Wire	Signal Name [Specification]
1	L	IGNITION POWER SUPPLY
2	P	BATTERY POWER SUPPLY (MEMORY BACK-UP)
3	L	CAN-H
4	R	CAN-L
5	BR	GROUND
6	GR	IGNITION POWER SUPPLY
7	BG	BACK-UP LAMP RELAY
8	P	CAN-L
9	V	STARTER RELAY
10	B	GROUND

Connector No.	F12
Connector Name	WIRE TO WIRE
Connector Type	SAA36FB-RS8-SH28

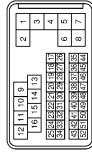

Terminal No.	Color Of Wire	Signal Name [Specification]
1	R	-
2	GR	-
3	BG	-
4	R	-
5	G	-
7	L	-
8	W	-
9	W	-
10	BG	-
11	R	-
12	LG	-
13	L	-
14	Y	-
15	LG	-
16	Y	-
17	L	-
18	P	-
19	GR	-
20	BG	-
21	GR	-
22	W	-
23	G	-
24	SB	-
25	V	-
26	V	-
27	W	-
28	W	-
29	Y	-
30	R	-
31	P	-
32	R	-
33	P	-
34	BG	-
35	LG	-
36	SB	-
37	V	-

Connector No.	M1
Connector Name	INTEGRAL SWITCH
Connector Type	TH24FW-AH

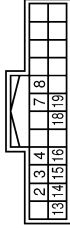

Terminal No.	Color Of Wire	Signal Name [Specification]
2	R	ILLUMINATION SIGNAL
3	LG	AV COMMUNICATION SIGNAL (L)
4	SB	AV COMMUNICATION SIGNAL (H)
7	W/B	DISK EJECT SIGNAL
8	G	HAZARD SIGNAL
13	B	GROUND
14	SB	ACC POWER SUPPLY [With 2.0L turbo gasoline engine]
14	V	ACC POWER SUPPLY [With VR30 engine]
15	B	ILLUMINATION CONTROL SIGNAL
16	BG	DISK EJECT SIGNAL
18	R	IGNITION SIGNAL [With VR30 engine]
18	W	IGNITION SIGNAL [With 2.0L turbo gasoline engine]
19	BR	CAMERA SWITCH SIGNAL

Connector No.	M2
Connector Name	INTEGRAL SWITCH
Connector Type	Teco_1554987-6



Terminal No.	Color Of Wire	Signal Name [Specification]
27	W	LWDS (+)
28	B	LWDS (-)
29	SHIELD	SHIELD

# REAR VIEW MONITOR SYSTEM

## [REAR VIEW MONITOR SYSTEM]

< WIRING DIAGRAM >

### REAR VIEW MONITOR SYSTEM (VR ENGINE)

Connector No.	M20
Connector Name	WIRE TO WIRE
Connector Type	TH16FW-AH

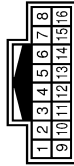

Connector No.	M39
Connector Name	WIRE TO WIRE
Connector Type	TH2FW-AH

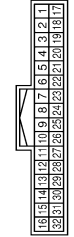

Connector No.	M77
Connector Name	STEERING ANGLE SENSOR
Connector Type	TH8FW-AH



Connector No.	M100
Connector Name	DISPLAY CONTROL UNIT
Connector Type	TH24FW-AH

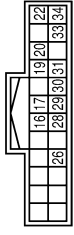

Terminal No.	Color Of Wire	Signal Name [Specification]
7	W	-
8	L	-
10	Y	-
11	SHIELD	- [Without Gateway]
12	B	- [With Gateway]
13	W	-
14	R	-

Connector No.	M25
Connector Name	DATA LINK CONNECTOR
Connector Type	BD16FW



Terminal No.	Color Of Wire	Signal Name [Specification]
1	W/B	-
2	SB	-
3	L	-
4	P	- [Without Gateway]
4	R	- [With Gateway]
5	BR	-
6	SB	-
7	L	-
8	W	-
9	P	- [Without BOSE system]
9	V	- [With BOSE system]
10	V	-
11	SB	-
12	G	-
13	G	-
15	R	-
16	SB	-
17	SHIELD	-
18	W	-
19	Y	-
20	L	-
21	G	-
22	R	-
23	BR	-
26	V	-
27	LG	-
28	BR	-
29	W/B	-
30	Y	-
31	W	-
32	LG	-

Terminal No.	Color Of Wire	Signal Name [Specification]
1	B	GROUND
2	P	CAN-L [Without Gateway]
2	R	CAN-L [With Gateway]
4	G	IGN
5	L	CAN-H

Connector No.	MP7
Connector Name	BACK-UP LAMP RELAY
Connector Type	MS02FL-M2-LC



Terminal No.	Color Of Wire	Signal Name [Specification]
3	LG	M/CAN-L
4	B	EARTH
5	B	EARTH
6	L	CAN-H
7	V	KLIME [With 2.0L turbo gasoline engine]
7	W	KLIME [With VRS0 engine]
8	W	IGN/SW
11	SB	M/CAN-H
12	R	CAN-L
13	L	CAN-H
14	P	CAN-L
16	W	POWER

Terminal No.	Color Of Wire	Signal Name [Specification]
16	LG	AV COMMUNICATION SIGNAL (L)
17	P	CAN-L
19	R	DIMMER SIGNAL
20	BR	REVERSE SIGNAL
22	B	GROUND
26	BR	CAMERA SWITCH SIGNAL
28	SB	AV COMMUNICATION SIGNAL (H)
29	L	CAN-H
30	R	IGNITION SIGNAL [With VRS0 engine]
30	W	IGNITION SIGNAL [With 2.0L turbo gasoline engine]
31	R	VEHICLE SPEED SIGNAL (B-PULSE)
33	SB	ACC POWER SUPPLY
34	Y	BATTERY POWER SUPPLY

Connector No.	M103
Connector Name	DISPLAY CONTROL UNIT
Connector Type	TH40FW-AH



Terminal No.	Color Of Wire	Signal Name [Specification]
36	LG	COMPOSITE IMAGE SIGNAL (-)
38	SHIELD	SHIELD
40	G	MANUFACTURER SPECIFIC SIGNAL
42	G	SOUND SIGNAL RH (-)
43	SHIELD	SHIELD
44	L	SOUND SIGNAL LH (-)
45	W	TEL VOICE SIGNAL (-)

A  
B  
C  
D  
E  
F  
G  
H  
I  
J  
K  
L  
M  
N  
O  
P

AV

# REAR VIEW MONITOR SYSTEM

< WIRING DIAGRAM >

[REAR VIEW MONITOR SYSTEM]

## REAR VIEW MONITOR SYSTEM (VR ENGINE)

Terminal No.	Color Of Wire	Signal Name [Specification]
46	SHIELD	SHIELD
47	R	VOICE GUIDANCE SIGNAL OUTPUT (+)
48	B	VOICE GUIDANCE SIGNAL INPUT (+)
49	W	NS ON/OFF SIGNAL
50	R	MICROPHONE SIGNAL GROUND (WITH NAVIGATION)
51	SHIELD	SHIELD
52	SHIELD	MICROPHONE SIGNAL GROUND
54	W	CAMERA POWER SUPPLY GROUND
55	SHIELD	SHIELD
56	BR	COMPOSITE IMAGE SIGNAL (+)
58	R	CAMERA IMAGE SIGNAL
60	W	SOUND SIGNAL (-)
61	R	SOUND SIGNAL (+)
62	R	SOUND SIGNAL RH (+)
63	SHIELD	SHIELD
64	V	SOUND SIGNAL LH (+)
65	B	TEL VOICE SIGNAL (+)
66	SHIELD	SHIELD
67	G	VOICE GUIDANCE SIGNAL OUTPUT (+)
68	W	SHIELD
69	G	MICROPHONE SIGNAL (NAV)
71	G	MICROPHONE SIGNAL (without telematics system)
71	R	MICROPHONE SIGNAL (with telematics system)
72	L	MICROPHONE VCC
74	R	CAMERA POWER SUPPLY

Connector No.	M105
Connector Name	DISPLAY CONTROL UNIT
Connector Type	Tyco_1554987-6

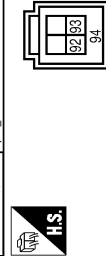

Terminal No.	Color Of Wire	Signal Name [Specification]
92	W	LVD5 (+)
93	B	LVD5 (-)
94	SHIELD	SHIELD

Connector No.	M132
Connector Name	FUSE BLOCK (I/B)
Connector Type	NS16FM-C5

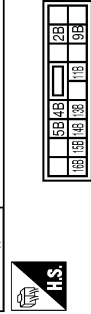

Terminal No.	Color Of Wire	Signal Name [Specification]
111B	LG	- [With VR30 engine]
138	P	- [With 2.0L turbo gasoline engine]
148	G	-
158	Y	-
168	Y	-
28	B	-
48	W	-
58	R	-
98	Y	-

Connector No.	M133
Connector Name	FUSE BLOCK (I/B)
Connector Type	TH40FW-AH

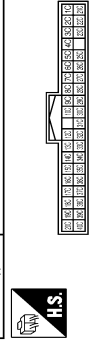

Terminal No.	Color Of Wire	Signal Name [Specification]
10C	V	-
12C	L	-
14C	Y	-
15C	R	-
16C	R	-
17C	L	-
18C	BG	- [Without DRPO]
18C	P	- [With DRPO]
19C	B	-
1C	R	-

Terminal No.	Color Of Wire	Signal Name [Specification]
20C	W	-
21C	L	-
22C	L	-
23C	L	-
24C	LG	-
25C	5B	-
26C	P	-
27C	W	-
28C	W	-
29C	W	-
2C	R	-
30C	R	-
31C	W	-
32C	R	-
33C	B	- [With VR30 engine]
33C	R	- [With 2.0L turbo gasoline engine]
34C	W/B	-
35C	5B	-
36C	R	-
37C	W	-
38C	5B	-
39C	V	-
3C	P	-
40C	G	-
4C	P	-
5C	P	-
6C	G	-
7C	G	-
8C	G	-
9C	V	-

Connector No.	M135
Connector Name	JOINT CONNECTOR-M09
Connector Type	2434Z_4GA2A

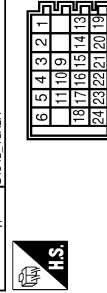

Terminal No.	Color Of Wire	Signal Name [Specification]
1	B	-
2	B	-
3	B	-
4	B	-
5	B	-

Terminal No.	Color Of Wire	Signal Name [Specification]
6	B	-
9	LG	-
10	LG	-
11	LG	-
13	B	- [With VR30 engine]
13	5B	- [With 2.0L turbo gasoline engine]
14	B	- [With VR30 engine]
14	5B	- [With 2.0L turbo gasoline engine]
15	B	- [With VR30 engine]
15	5B	- [With 2.0L turbo gasoline engine]
16	5B	- [With 2.0L turbo gasoline engine]
16	Y	- [With VR30 engine]
17	5B	- [With 2.0L turbo gasoline engine]
17	Y	- [With VR30 engine]
18	5B	- [With 2.0L turbo gasoline engine]
18	Y	- [With VR30 engine]
19	SHIELD	-
20	R	-
21	R	-
22	SHIELD	-
23	L	-
24	L	-

Connector No.	M144
Connector Name	TCU
Connector Type	TH40FB-AH

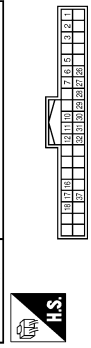

Terminal No.	Color Of Wire	Signal Name [Specification]
1	Y	BATTERY POWER SUPPLY
2	5B	ACC POWER SUPPLY (With 2.0L turbo gasoline engine)
2	Y	ACC POWER SUPPLY (With VR30 engine)
3	5B	ACC OUTPUT
5	BR	SOS SWITCH-LED SIGNAL
6	L	CAN-L
7	P	CAN-H
10	R	IGNITION SIGNAL (With VR30 engine)
10	W	IGNITION SIGNAL (With 2.0L turbo gasoline engine)
11	SHIELD	MICROPHONE SIGNAL GROUND
12	R	MICROPHONE SIGNAL
16	SHIELD	SHIELD

# REAR VIEW MONITOR SYSTEM

## [REAR VIEW MONITOR SYSTEM]

< WIRING DIAGRAM >

### REAR VIEW MONITOR SYSTEM (VR ENGINE)

17	G	MICROPHONE SIGNAL
18	L	MICROPHONE VCC
26	SB	AV COMMUNICATION SIGNAL (H)
27	LG	AV COMMUNICATION SIGNAL (L)
28	B	GROUND
29	R	GROUND
30	SHIELD	SHIELD
31	B	SOUND SIGNAL (A)
32	W	SOUND SIGNAL (L)
37	G	SOS CALL SWITCH SIGNAL

Connector No.	M173
Connector Name	JOINT CONNECTOR-M03
Connector Type	24342_4GA2A

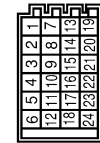

Connector No.	M175
Connector Name	JOINT CONNECTOR-M05
Connector Type	MH20FL-DC

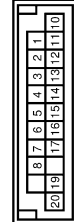

20	LG	- [With 2.0L turbo gasoline engine]
21	BR	- [With VR30 engine]
21	LG	- [With 2.0L turbo gasoline engine]
22	R	- [With 2.0L turbo gasoline engine]
22	SB	- [With VR30 engine]
23	R	- [With 2.0L turbo gasoline engine]
23	SB	- [With VR30 engine]
24	B	- [With 2.0L turbo gasoline engine]
24	SB	- [With VR30 engine]



Connector No.	M177
Connector Name	JOINT CONNECTOR-M07
Connector Type	24342_4GA2A



Terminal No.	Color Of Wire	Signal Name [Specification]
1	L	-
3	L	-
4	L	-
5	L	-
6	L	-
7	P	-
9	P	-
10	P	-
11	P	-
12	P	-
16	L	-
17	L	-
18	L	-
22	P	-
23	P	-
24	P	-

Connector No.	T48
Connector Name	WIRE TO WIRE
Connector Type	NS16FW-C5



Terminal No.	Color Of Wire	Signal Name [Specification]
1	Y	-
2	BG	-
4	L	-
5	P	-

6	G	-
8	B	-
9	R	-
10	P	-
11	L	-
13	G	- [With around view monitor]
13	L	- [With rear view monitor]
14	B	- [With rear view monitor]
14	R	- [With around view monitor]
15	B	- [With around view monitor]
15	W	- [With rear view monitor]
16	R	- [With rear view monitor]
16	W	- [With around view monitor]

Connector No.	T54
Connector Name	REAR VIEW CAMERA
Connector Type	RH06FB-1V



Terminal No.	Color Of Wire	Signal Name [Specification]
1	W	-
2	R	-
4	B	-
5	L	-

A  
B  
C  
D  
E  
F  
G  
H  
I  
J  
K  
L  
M  
N  
O  
P

AV

## BASIC INSPECTION

### DIAGNOSIS AND REPAIR WORKFLOW

#### Work Flow

INFOID:000000013717629

#### OVERALL SEQUENCE

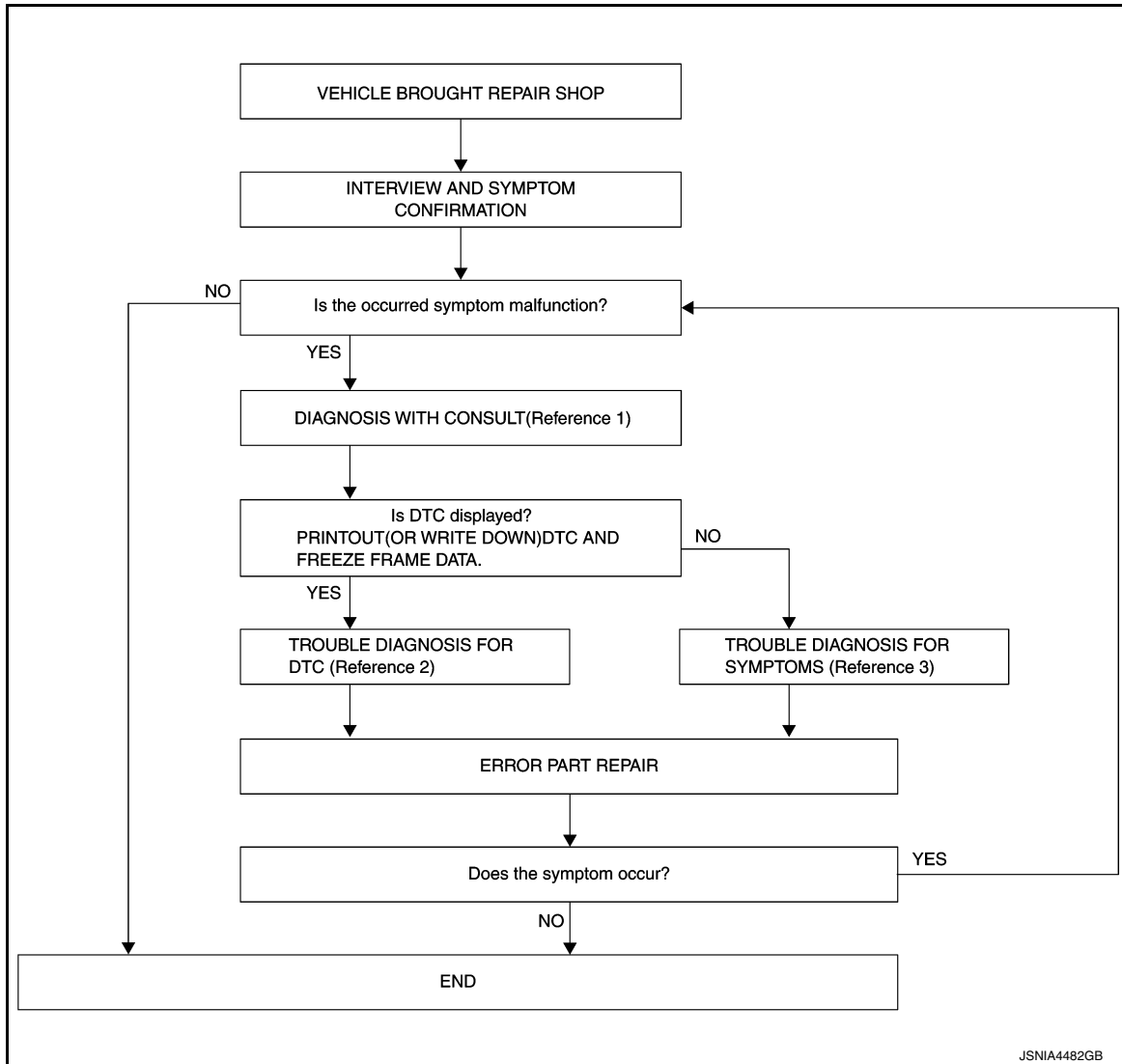

JSNIA4482GB

- Reference 1… Refer to [AV-685, "CONSULT Function"](#).
- Reference 2… Refer to [AV-695, "DTC Index"](#).
- Reference 3… Refer to [AV-722, "Symptom Table"](#).

#### DETAILED FLOW

##### 1. INTERVIEW AND SYMPTOM CONFIRMATION

Check the malfunction symptoms by performing the following items.

- Interview the customer to obtain the malfunction information (conditions and environment when the malfunction occurred).
- Check the symptom.

##### Is the occurred symptom malfunction?

YES >> GO TO 2.

NO >> INSPECTION END

##### 2. DIAGNOSIS WITH CONSULT

# DIAGNOSIS AND REPAIR WORKFLOW

## [REAR VIEW MONITOR SYSTEM]

### < BASIC INSPECTION >

1. Connect CONSULT and perform a self-diagnosis for "MULTI AV". Refer to [AV-685, "CONSULT Function"](#).

**NOTE:**

Skip to step 4 of the diagnosis procedure if "MULTI AV" is not displayed.

2. When DTC is detected, follow the instructions below:
  - Record DTC and Freeze Frame Data.

Is DTC displayed?

YES >> GO TO 3.

NO >> GO TO 4.

### 3. TROUBLE DIAGNOSIS FOR DTC

1. Check the DTC indicated in the "Self-Diagnosis Results".
2. Perform the relevant diagnosis referring to the DTC Index. Refer to [AV-695, "DTC Index"](#).

>> GO TO 5.

### 4. TROUBLE DIAGNOSIS FOR SYMPTOMS

Perform the relevant diagnosis referring to the diagnosis chart by symptom. Refer to [AV-722, "Symptom Table"](#).

>> GO TO 5.

### 5. ERROR PART REPAIR

1. Repair or replace the identified malfunctioning parts.
2. Perform a self-diagnosis for "MULTI AV" with CONSULT.

**NOTE:**  
Erase the stored self-diagnosis results after repairing or replacing the relevant components if any DTC has been indicated in the "Self-Diagnosis Results".
3. Check that the symptom does not occur.

Does the symptom occur?

YES >> GO TO 1.

NO >> INSPECTION END

A  
B  
C  
D  
E  
F  
G  
H  
I  
J  
K  
L  
M  
O  
P

AV

# POWER SUPPLY AND GROUND CIRCUIT

[REAR VIEW MONITOR SYSTEM]

< DTC/CIRCUIT DIAGNOSIS >

## DTC/CIRCUIT DIAGNOSIS

### POWER SUPPLY AND GROUND CIRCUIT DISPLAY CONTROL UNIT

#### DISPLAY CONTROL UNIT : Diagnosis Procedure

INFOID:0000000013974162

#### 1. CHECK FUSE

1. Turn ignition switch OFF.
2. Check that the following fuse is not blown (open).

2.0L turbo gasoline engine

Power source	Fuse No.	Capacity
Battery	#84	15 A
Ignition switch ACC	#93*	10 A
Ignition switch ON	#77	10 A

\*: Without navigation system

VR30DDTT

Power source	Fuse No.	Capacity
Battery	#7	15 A
Ignition switch ACC	#1*	10 A
Ignition switch ON	#14	5 A

\*: Without navigation system

#### Is the fuse blown (open)?

- YES >> Replace fuse after repairing the applicable circuit.  
NO >> GO TO 2.

#### 2. CHECK DISPLAY CONTROL UNIT BATTERY POWER SUPPLY

1. Turn ignition switch OFF.
2. Disconnect display control unit harness connector.
3. Check the voltage between display control unit harness connector and ground.

Terminals		Voltage
(+)	(-)	
Display control unit		Battery voltage
Connector	Terminal	
M100	34	
	Ground	

#### Is the inspection result normal?

- YES >> GO TO 3.  
NO >> Perform trouble diagnosis for battery power supply circuit.

#### 3. CHECK DISPLAY CONTROL UNIT ACCESSORY POWER SUPPLY

1. Turn ignition switch ON.
2. Check the voltage between display control unit harness connector and ground.

Terminals		Voltage
(+)	(-)	
Display control unit		Battery voltage
Connector	Terminal	
M100	33	
	Ground	

# POWER SUPPLY AND GROUND CIRCUIT

[REAR VIEW MONITOR SYSTEM]

< DTC/CIRCUIT DIAGNOSIS >

Is the inspection result normal?

YES >> GO TO 4.

NO >> Perform trouble diagnosis for accessory power supply circuit.

## 4. CHECK DISPLAY CONTROL UNIT IGNITION POWER SUPPLY

Check the voltage between display control unit harness connector and ground.

Terminals		(-)	Voltage
(+)			
Display control unit			
Connector	Terminal	Ground	Battery voltage
M100	30		

Is the inspection result normal?

YES >> GO TO 5.

NO >> Perform trouble diagnosis of ignition power supply circuit.

## 5. CHECK GROUND CIRCUIT

1. Turn ignition switch OFF.
2. Check the continuity between display control unit and ground.

Terminals		(-)	Continuity
(+)			
Display control unit			
Connector	Terminal	Ground	Existed
M100	22		

Is the inspection result normal?

YES >> INSPECTION END

NO >> Repair or replace malfunctioning parts.

A  
B  
C  
D  
E  
F  
G  
H  
I  
J  
K  
L  
M

AV

O  
P

# CAMERA IMAGE SIGNAL CIRCUIT (WITH REAR VIEW MONITOR)

< DTC/CIRCUIT DIAGNOSIS >

[REAR VIEW MONITOR SYSTEM]

## CAMERA IMAGE SIGNAL CIRCUIT (WITH REAR VIEW MONITOR)

### Description

INFOID:000000013717631

- The display control unit supplies power to the rear view camera when receiving a reverse signal.
- The rear view camera transmits camera images to the display control unit when power is supplied from the display control unit.

### Diagnosis Procedure

INFOID:000000013717632

#### 1. CHECK CAMERA IMAGE SIGNAL

1. Turn ignition switch ON.
2. Shift the selector lever to "R" position.
3. Check the signal between display control unit harness connector and ground.

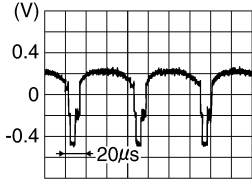
Display control unit		Condition	Reference value
Connector	Terminals		
	(+) (-)		
Terminal			
M101	58 22	At rear view camera image is displayed.	 <p>SKIB0827E</p>

Is the inspection result normal?

- YES >> Replace display control unit. Refer to [AV-724, "Removal and Installation"](#).  
 NO >> GO TO 2.

#### 2. CHECK CAMERA IMAGE SIGNAL CIRCUIT FOR OPEN

1. Turn ignition switch OFF.
2. Disconnect display control unit connector and rear view camera harness connector.
3. Check the continuity between display control unit harness connector and rear view camera harness connector.

Display control unit		Rear view camera		Continuity
Connector	Terminal	Connector	Terminal	
M101	58	T54	4	Existed

Is the inspection result normal?

- YES >> GO TO 3.  
 NO >> Repair or replace malfunctioning parts.

#### 3. CHECK CAMERA IMAGE SIGNAL CIRCUIT FOR SHORT

Check the continuity between display control unit harness connector and ground.

Terminals		Continuity	
(+)	(-)		
Display control unit			
Connector	Terminal		
M101	58	Ground	Not existed

Is the inspection result normal?

- YES >> GO TO 4.

# CAMERA IMAGE SIGNAL CIRCUIT (WITH REAR VIEW MONITOR)

[REAR VIEW MONITOR SYSTEM]

< DTC/CIRCUIT DIAGNOSIS >

NO >> Repair or replace malfunctioning parts.

## 4. CHECK CAMERA IMAGE SIGNAL GROUND CIRCUIT

Check the continuity between display control unit harness connector and rear view camera harness connector.

Display control unit		Rear view camera		Continuity
Connector	Terminal	Connector	Terminal	
M101	38	T54	5	Existed

Is the inspection result normal?

YES >> Replace rear view camera. Refer to [AV-725. "Removal and Installation"](#).

NO >> Repair or replace malfunctioning parts.

A  
B  
C  
D  
E  
F  
G  
H  
I  
J  
K  
L  
M  
O  
P

AV

# REVERSE SIGNAL CIRCUIT

< DTC/CIRCUIT DIAGNOSIS >

[REAR VIEW MONITOR SYSTEM]

## REVERSE SIGNAL CIRCUIT

### Component Function Check

INFOID:000000013717633

#### 1.CHECK REVERSE SIGNAL

④ With CONSULT

1. Turn ignition ON.
2. Select "REV SIG" in "DATA MONITOR" mode of "MULTI AV" using CONSULT.
3. Check "REV SIG" indication as per the following condition.

Monitor item	Condition		Indication
REV SIG	Selector lever position	R position	On
		Other than R position	Off

Is the inspection result normal?

- YES >> INSPECTION END  
NO >> Proceed to [AV-720, "Diagnosis Procedure"](#).

### Diagnosis Procedure

INFOID:000000013717634

#### 1.CHECK REVERSE RANGE SIGNAL

1. Turn ignition switch ON.
2. Check the voltage between display control unit harness connector and ground as per the following condition.

Display control unit			Condition	Reference value
Connector	Terminals			
	(+)	(-)		
Terminal				
M100	20	22	Shift the selector lever to R position.	12.0 V
			Shift the selector lever other than R position.	0 V

Is the inspection result normal?

- YES >> Replace display control unit. Refer to [AV-724, "Removal and Installation"](#).  
NO >> GO TO 2.

#### 2.CHECK REVERSE SIGNAL CIRCUIT

1. Turn ignition switch OFF.
2. Disconnect display control unit harness connector.
3. Remove back-up lamp relay.
4. Check the continuity between display control unit harness connector and back-up lamp relay harness connector.

Display control unit		Back-up lamp relay		Continuity
Connector	Terminal	Connector	Terminal	
M100	20	M97	5	Existed

Is the inspection result normal?

- YES >> GO TO 3.  
NO >> Repair or replace malfunctioning parts.

#### 3.CHECK BACK-UP LAMP POWER SUPPLY

1. Turn ignition switch ON.
2. Check the voltage between back-up lamp relay harness connector and ground.

# REVERSE SIGNAL CIRCUIT

[REAR VIEW MONITOR SYSTEM]

< DTC/CIRCUIT DIAGNOSIS >

Terminals		Voltage (Approx.)
(+)		
Back-up lamp relay		Ground
Connector	Terminal	
M97	1	Battery voltage
	3	

Is the inspection result normal?

- YES >> GO TO 4.
- NO >> Check ignition power supply circuit.

## 4. CHECK BACK-UP LAMP RELAY

1. Turn ignition switch OFF.
2. Check the back-up lamp relay. Refer to [AV-721, "Component Inspection"](#).

Is the inspection result normal?

- YES-1 >> VR30DDTT: Perform "self diagnostic result" in "TRANSMISSION". Refer to [TM-86, "2.0L TURBO GASOLINE ENGINE : CONSULT Function"](#).
- YES-2 >> 2.0L turbo gasoline engine: Perform "self diagnostic result" in "ENGINE". Refer to [EC4-100, "CONSULT Function"](#).
- NO >> Replace back-up lamp relay.

## Component Inspection

INFOID:000000013717635

### 1. CHECK BACK-UP LAMP RELAY

1. Turn ignition switch OFF.
2. Remove back-up lamp relay.
3. Check the continuity between back-up lamp relay terminals as per the following condition.

Back-up lamp relay		Condition	Continuity
Terminal			
3	5	12 V direct current supply between terminals 1 and 2	Existed
		No current supply	Not existed

Is the inspection result normal?

- YES >> INSPECTION END
- NO >> Replace back-up lamp relay.

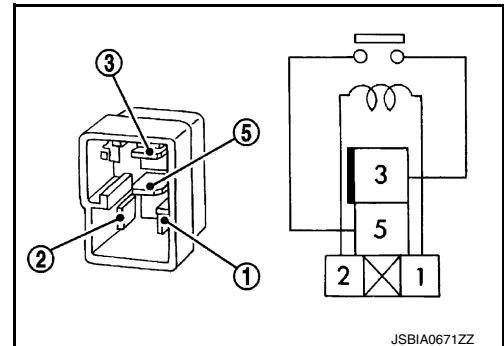

JSBIA0671ZZ

# REAR VIEW MONITOR SYSTEM

< SYMPTOM DIAGNOSIS >

[REAR VIEW MONITOR SYSTEM]

## SYMPTOM DIAGNOSIS

### REAR VIEW MONITOR SYSTEM

#### Symptom Table

INFOID:0000000013717636

#### REAR VIEW MONITOR SYSTEM

Symptoms	Possible cause	Inspection item
Camera image is not shown. (Vehicle width and predictive course line are displayed.)	<ul style="list-style-type: none"><li>• Harness between rear view camera and display control unit</li><li>• Rear view camera</li><li>• Display control unit</li></ul>	Camera image signal circuit. Refer to <a href="#">AV-718</a> . "Diagnosis Procedure".
Camera image does not switch.	<ul style="list-style-type: none"><li>• Harness between back-up lamp relay and display control unit</li><li>• Ignition power supply circuit</li><li>• Back-up lamp relay</li><li>• Display control unit</li><li>• TCM</li></ul>	Reverse signal circuit. Refer to <a href="#">AV-720</a> . "Diagnosis Procedure".

# NORMAL OPERATING CONDITION

< SYMPTOM DIAGNOSIS >

[REAR VIEW MONITOR SYSTEM]

## NORMAL OPERATING CONDITION

### Description

INFOID:000000013717637

#### NOTE:

For Navigation system operation information, refer to Navigation system Owner's Manual.

#### BASIC OPERATIONS

Symptom	Possible cause	Possible solution
No image is displayed.	The brightness is at the lowest setting.	Adjust the brightness of the display.
	The systems in the video mode.	Press "DISC-AUX" to change the mode.
	The display is turned off.	Press "☀/☾" to turn on the display.
	The interior of the vehicle becomes the a little less than 80°C (176°F) or high temperature, and the protection of the display acts, and a display is turned off.	Wait until the interior of the vehicle has cooled down.
Screen not clear.	Contrast setting is not appropriate.	Adjust the contrast of the display.
No voice guidance is available. Or The volume is too high or too low.	The volume is not set correctly, or it is turned off.	Adjust the volume of voice guidance.
	Voice guidance is not provided for certain streets (roads displayed in gray).	This is not a malfunction.
No map is displayed on the screen.	A screen other than map screen is displayed.	Press "MAP".
The screen is too dim. The movement is slow.	The temperature in the interior of the vehicle is low.	Wait until the interior of the vehicle has warmed up.
Some pixels in the display are darker or brighter than others.	This condition is an inherent characteristic of liquid crystal displays.	This is not a malfunction.
Some menu items cannot be selected.	Some menu items become unavailable while the vehicle is driven.	Park the vehicle in a safe location, and then operate the navigation system.

#### NOTE:

Locations stored in the Address Book and other memory functions may be lost if the vehicle's battery is disconnected or becomes discharged. If this occurs, service the vehicle's battery as necessary and re-enter the information in the Address Book.

A  
B  
C  
D  
E  
F  
G  
H  
I  
J  
K  
L  
M  
O  
P

AV

## REMOVAL AND INSTALLATION

### DISPLAY CONTROL UNIT

#### Removal and Installation

INFOID:000000013974161

#### REMOVAL

##### CAUTION:

- Before replacing display control unit, perform “Read/Write Configuration” to save or print current vehicle specification. For details, refer to [AV-289, "Description"](#).
- Remove battery terminal and display control unit after a lapse of 30 seconds or more after turning the ignition switch OFF.

##### NOTE:

- After the ignition switch is turned OFF, the display control unit continues operating for approximately 30 seconds. Therefore, data corruption may occur if battery voltage is cut off within 30 seconds.
  - Downloaded applications are deleted when display control unit is replaced.
1. Remove the integral switch. Refer to [AV-435, "Removal and Installation"](#).
  2. Remove the bracket screws (A).
  3. Disconnect the harness connector from the display control unit (1).
  4. Remove the bracket from display control unit.

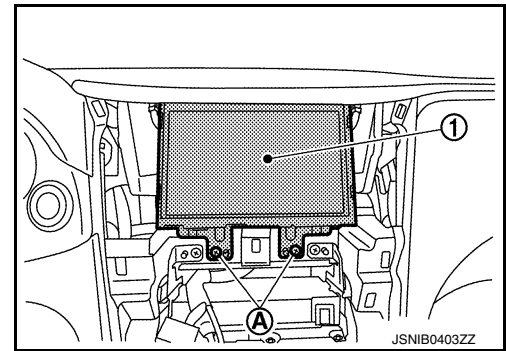

#### INSTALLATION

Install in the reverse order of removal.

##### CAUTION:

Be sure to perform “Read/Write Configuration” when replacing display control unit. For details, refer to [AV-289, "Description"](#).

## REAR VIEW CAMERA

### Removal and Installation

INFOID:000000013717639

#### REMOVAL

1. Remove the trunk lid trim. Refer to [INT-43, "Removal and Installation"](#).
2. Remove the rear view camera mounting screws (A).
3. Disconnect the harness connector (B) to remove the rear view camera (1).

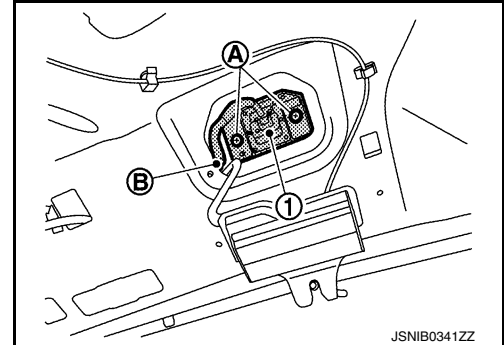

#### INSTALLATION

Install in the reverse order of removal.

#### NOTE:

Adjust the guide line position if the guide line position is shifted after installing the rear view camera. Refer to [AV-725, "Adjustment"](#).

#### Adjustment

INFOID:000000013717640

If the side distance guiding lines are dislocated after installation of the rear view camera, adjust the position of the side distance guiding lines.

1. Draw the correction lines at the rear of the vehicle passing through the following points: 20 cm from both sides of the vehicle, and 0.5 m and 1.0 m from the rear end of the bumper.
2. Set "Adjust offset of rear view camera" mode in Confirmation/Adjustment mode.

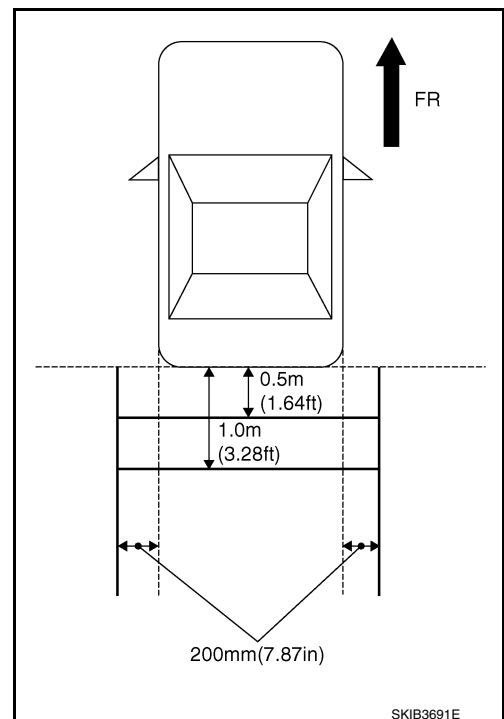

A  
B  
C  
D  
E  
F  
G  
H  
I  
J  
K  
L  
M  
AV  
O  
P

# REAR VIEW CAMERA

## < REMOVAL AND INSTALLATION >

## [REAR VIEW MONITOR SYSTEM]

3. Operate the touch panel and select the guiding line pattern so that its angle is aligned with the correction line of the rear of the vehicle.

Selection range       $(-10^{\circ}) - (+10^{\circ})$  in increments of  $0.2^{\circ}$  step

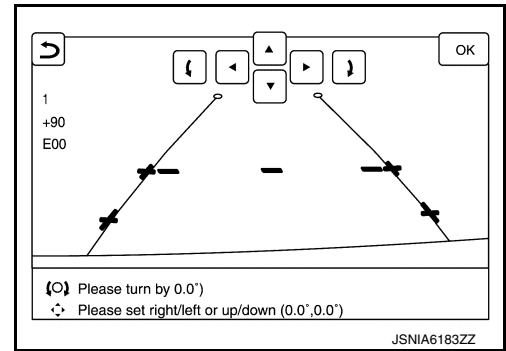

4. Press the upper/lower/left/right switch to perform the fine adjustment of the guiding lines so that the position of the guiding lines is aligned with the correction lines of the rear of the vehicle. The position of adjusted guiding line is recorded to the display control unit by pressing the "OK" switch.

### **CAUTION:**

**Never perform other operations while the guiding line position is memorized.**

Upper/lower adjustment range       $(-10^{\circ}) - (+10^{\circ})$  in increments of  $0.2^{\circ}$  step

Left/right adjustment range       $(-10^{\circ}) - (+10^{\circ})$  in increments of  $0.2^{\circ}$  step

# STEERING ANGLE SENSOR

< REMOVAL AND INSTALLATION >

[REAR VIEW MONITOR SYSTEM]

## STEERING ANGLE SENSOR

### Removal and Installation

INFOID:000000013717641

#### REMOVAL

1. Remove the spiral cable. Refer to [SR-21, "Removal and Installation"](#).
2. Remove the steering angle sensor from spiral cable.

#### INSTALLATION

Install in the reverse order of removal.

A

B

C

D

E

F

G

H

I

J

K

L

M

AV

O

P

PRECAUTION

PRECAUTIONS

Precaution for Supplemental Restraint System (SRS) "AIR BAG" and "SEAT BELT PRE-TENSIONER"

INFOID:000000014286330

The Supplemental Restraint System such as "AIR BAG" and "SEAT BELT PRE-TENSIONER", used along with a front seat belt, helps to reduce the risk or severity of injury to the driver and front passenger for certain types of collision. This system includes seat belt switch inputs and dual stage front air bag modules. The SRS system uses the seat belt switches to determine the front air bag deployment, and may only deploy one front air bag, depending on the severity of a collision and whether the front occupants are belted or unbelted. Information necessary to service the system safely is included in the "SRS AIR BAG" and "SEAT BELT" of this Service Manual.

**WARNING:**

Always observe the following items for preventing accidental activation.

- To avoid rendering the SRS inoperative, which could increase the risk of personal injury or death in the event of a collision that would result in air bag inflation, it is recommended that all maintenance and repair be performed by an authorized NISSAN/INFINITI dealer.
- Improper repair, including incorrect removal and installation of the SRS, can lead to personal injury caused by unintentional activation of the system. For removal of Spiral Cable and Air Bag Module, see "SRS AIR BAG".
- Never use electrical test equipment on any circuit related to the SRS unless instructed to in this Service Manual. SRS wiring harnesses can be identified by yellow and/or orange harnesses or harness connectors.

PRECAUTIONS WHEN USING POWER TOOLS (AIR OR ELECTRIC) AND HAMMERS

**WARNING:**

Always observe the following items for preventing accidental activation.

- When working near the Air Bag Diagnosis Sensor Unit or other Air Bag System sensors with the ignition ON or engine running, never use air or electric power tools or strike near the sensor(s) with a hammer. Heavy vibration could activate the sensor(s) and deploy the air bag(s), possibly causing serious injury.
- When using air or electric power tools or hammers, always switch the ignition OFF, disconnect the battery or batteries, and wait at least 3 minutes before performing any service.

Precaution for Battery Service

INFOID:000000014286331

Before disconnecting the battery, lower both the driver and passenger windows. This will prevent any interference between the window edge and the vehicle when the door is opened/closed. During normal operation, the window slightly raises and lowers automatically to prevent any window to vehicle interference. The automatic window function will not work with the battery disconnected.

Precautions for Removing Battery Terminal

INFOID:000000014286332

When disconnecting the battery terminal, pay attention to the following.

- Always use a 12V battery as power source.
- Never disconnect battery terminal while engine is running.
- When removing the 12V battery terminal, turn OFF the ignition switch and wait at least 30 seconds.
- For vehicles with the engine listed below, remove the battery terminal after a lapse of the specified time:

BR08DE	: 4 minutes	YD25DDTi	: 2 minutes
D4D engine	: 20 minutes	YS23DDT	: 4 minutes
HRA2DDT	: 12 minutes	YS23DDTT	: 4 minutes
K9K engine	: 4 minutes	ZD30DDTi	: 60 seconds
M9R engine	: 4 minutes	ZD30DDTT	: 60 seconds
R9M engine	: 4 minutes		
V9X engine	: 4 minutes		

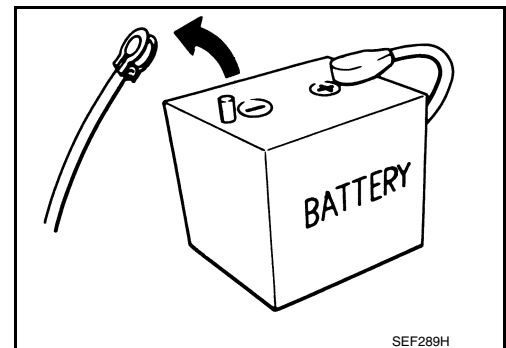

SEF289H

# PRECAUTIONS

[TELEMATICS SYSTEM]

< PRECAUTION >

## NOTE:

ECU may be active for several tens of seconds after the ignition switch is turned OFF. If the battery terminal is removed before ECU stops, then a DTC detection error or ECU data corruption may occur.

- After high-load driving, if the vehicle is equipped with the V9X engine, turn the ignition switch OFF and wait for at least 15 minutes to remove the battery terminal.

## NOTE:

- Turbocharger cooling pump may operate in a few minutes after the ignition switch is turned OFF.
- Example of high-load driving
  - Driving for 30 minutes or more at 140 km/h (86 MPH) or more.
  - Driving for 30 minutes or more on a steep slope.
- For vehicles with the 2-batteries, be sure to connect the main battery and the sub battery before turning ON the ignition switch.

## NOTE:

If the ignition switch is turned ON with any one of the terminals of main battery and sub battery disconnected, then DTC may be detected.

- After installing the 12V battery, always check "Self Diagnosis Result" of all ECUs and erase DTC.

## NOTE:

The removal of 12V battery may cause a DTC detection error.

## Precaution for Trouble Diagnosis

INFOID:000000013717644

## AV COMMUNICATION SYSTEM

- Do not apply voltage of 7.0 V or higher to the measurement terminals.
- Use the tester with its open terminal voltage being 7.0 V or less.
- Be sure to turn ignition switch OFF and disconnect the battery cable from the negative terminal before checking the circuit.

## Precaution for Harness Repair

INFOID:000000013717645

## AV COMMUNICATION SYSTEM

- Solder the repaired parts, and wrap with tape. [Frays of twisted line must be within 110 mm (4.33 in).]

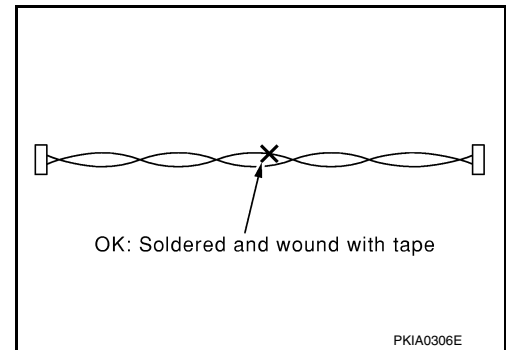

- Do not perform bypass wire connections for the repair parts. (The spliced wire will become separated and the characteristics of twisted line will be lost.)

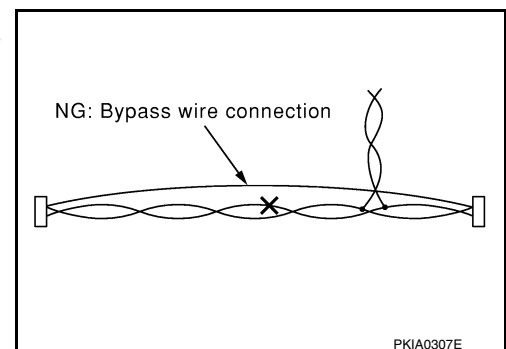

A  
B  
C  
D  
E  
F  
G  
H  
I  
J  
K  
L  
M  
AV  
O  
P

PREPARATION

PREPARATION

Commercial Service Tools

INFOID:000000013717646

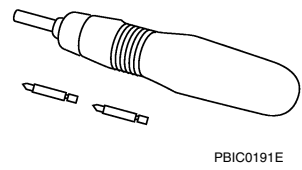
Tool	Description
<p data-bbox="162 514 276 546">Power tool</p>  <p data-bbox="820 619 901 651">PBIC0191E</p>	<p data-bbox="1006 514 1193 546">Loosening screws</p>

SYSTEM DESCRIPTION

COMPONENT PARTS

Component Parts Location

INFOID:000000013717647

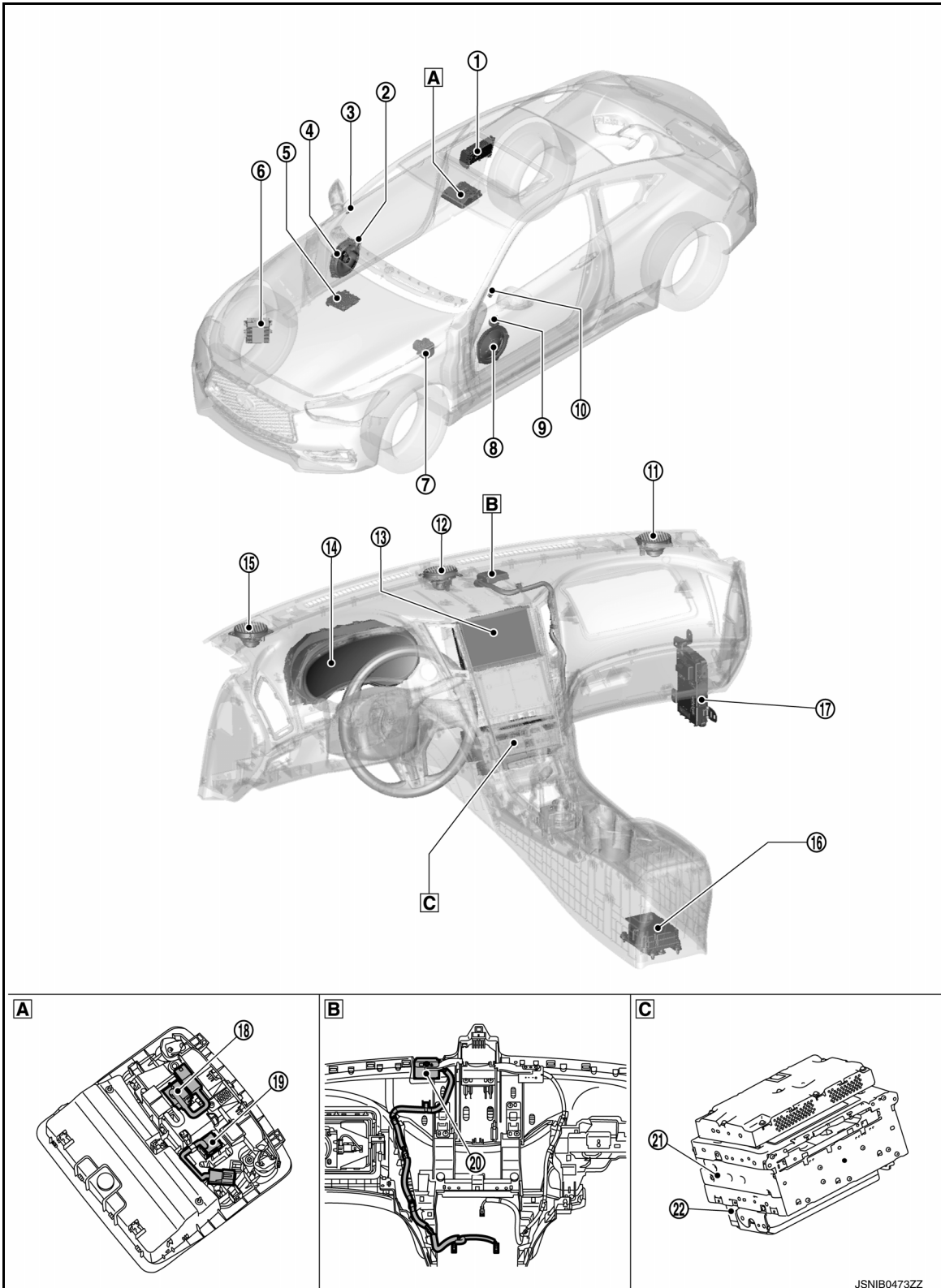

A  
B  
C  
D  
E  
F  
G  
H  
I  
J  
K  
L  
M

AV

O  
P

**A** Map lamp

**B** Instrument panel removed

**C** Back of integral switch

JSNIB0473ZZ

# COMPONENT PARTS

< SYSTEM DESCRIPTION >

[TELEMATICS SYSTEM]

No.	Part name	Description
①	BOSE amp.	Inputs sound signal from AV control unit, and outputs sound signal to each speaker.
②	Door squawker RH	Outputs sound signal.
③	Tweeter RH	Outputs sound signal.
④	Door woofer RH	Outputs sound signal.
⑤	ECM (2.0L turbo gasoline engine)	Transmits the following signals to the TCU via CAN communication. <ul style="list-style-type: none"> <li>• Malfunctioning indicator lamp signal</li> <li>• Engine status signal</li> </ul> Refer to <a href="#">EC4-25. "ENGINE CONTROL SYSTEM : Component Parts Location"</a> , for detailed installation location.
⑥	ECM (VR30DDTT)	Transmits the following signals to the TCU via CAN communication. <ul style="list-style-type: none"> <li>• Malfunctioning indicator lamp signal</li> <li>• Engine status signal</li> </ul>
⑦	ABS actuator and electric unit (control unit)	Transmits the following signals to the TCU via CAN communication. <ul style="list-style-type: none"> <li>• ABS warning lamp signal</li> <li>• VDC warning lamp signal</li> </ul> Refer to <a href="#">BRC-11. "Component Parts Location"</a> , for detailed installation location.
⑧	Door woofer LH	Outputs sound signal.
⑨	Door squawker LH	Outputs sound signal.
⑩	Tweeter LH	Outputs sound signal.
⑪	Front squawker RH	Outputs sound signal.
⑫	Center squawker RH	Outputs sound signal.
⑬	Display control unit	Refer to <a href="#">AV-732. "Display Control Unit"</a> .
⑭	Combination meter	Transmits the brake warning lamp signal to the TCU via CAN communication.
⑮	Front squawker LH	Outputs sound signal.
⑯	Air bag diagnosis sensor unit	Transmits the car crash information signal to the TCU via CAN communication. Refer to <a href="#">SRC-6. "Component Parts Location"</a> , for detailed installation location.
⑰	BCM	Transmits the following signals to the TCU via CAN communication. <ul style="list-style-type: none"> <li>• Door lock status signal</li> <li>• Oil pressure switch signal</li> </ul>
⑱	Telematics switch	Refer to <a href="#">AV-734. "Telematics Switch"</a> .
⑲	Microphone	Refer to <a href="#">AV-734. "Microphone"</a> .
⑳	Telematics antenna	Refer to <a href="#">AV-733. "Telematics Antenna"</a> .
㉑	AV control unit	Inputs sound signal from display control unit, and outputs sound signal to BOSE amp.
㉒	TCU	Refer to <a href="#">AV-733. "TCU"</a> .

## Display Control Unit

INFOID:000000013717648

- Display control unit is installed at the center of the instrument panel.
- It is connected to TCU with the USB harness and signals necessary for telematics function is sent and received.
- Switch operation signals used for the Telematics system are transmitted to TCU via USB communication from the display control unit.

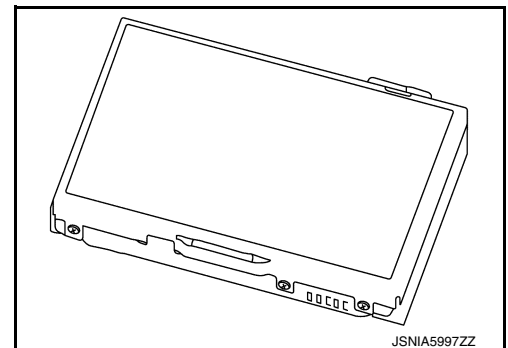

## TCU

INFOID:000000013717649

- TCU is abbreviation of Telematics Communication Unit.
- It is installed on the back of integral switch.
- A radio communication terminal and SIM card are built into the unit and data is sent and received in SMS<sup>\*1</sup>, DTMF tone signal and packet communication<sup>\*2</sup> with the Infiniti Connection™ Data Center through the TEL antenna.

**NOTE:**

\*1: SMS stands for Short Message Service. It is also referred to as Text Messaging, Short Mail, etc. It is the service that performs text based message communication.

\*2: Packet communication means a communication method that data are broken down into smaller chunks for communication. The split data is called a packet and this method improves the efficiency of the communication circuit.

- It is connected to the display control unit with the USB harness for sound signal input/output and USB communication.
- VIN information necessary for the Telematics service is memorized.
- It is connected to the air bag diagnosis sensor unit via CAN communication. TCU performs an emergency report when the air bag is inflated.
- Audio signals received during SOS/Infiniti Connection™ Response Specialists call are transmitted from TCU to each speaker via the display control unit and AV control unit.
- During the communication with Infiniti Connection™ Data Center and Infiniti Connection™ Response Center, TCU prohibit the use of Bluetooth® hands-free phone.

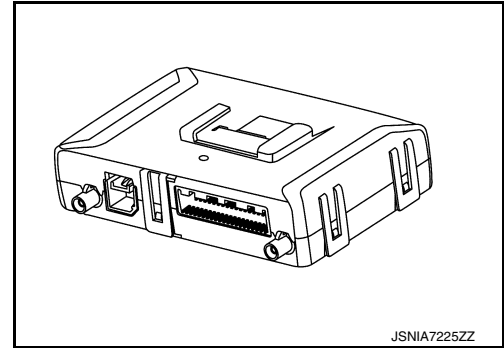

## Telematics Antenna

INFOID:000000013717650

- Telematics antenna consists of TEL antenna and GPS antenna.
- It is installed in the instrument panel.

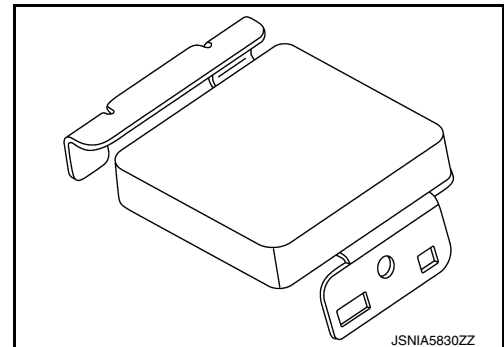

### TEL ANTENNA

- Data communications signals and voice signals are transmitted/received.
- Power is supplied with TCU activated.

### GPS ANTENNA

GPS signal is received and transmitted to TCU.

**NOTE:**

The placement of an object on the instrument panel may cause desensitization in the receiver sensitivity.

### FEEDER LAYOUT

A  
B  
C  
D  
E  
F  
G  
H  
I  
J  
K  
L  
M  
O  
P

AV

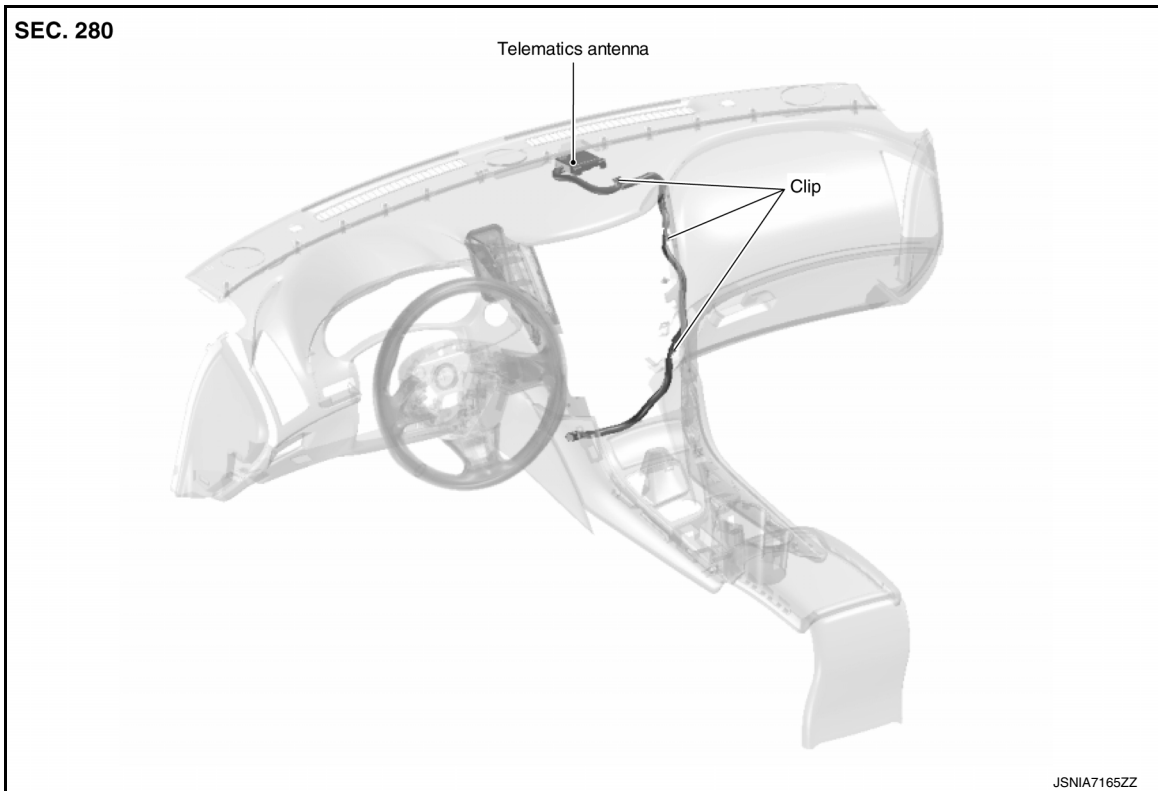

## Microphone

INFOID:000000013717651

- Microphone is installed on the map lamp assembly.
- The microphone is used for hands-free phone and voice recognition function in addition to the Infiniti Connection™ Response service of Infiniti Connection™.
- TCU supplies power to the microphone.
- An audio signal during speech is transmitted to TCU.

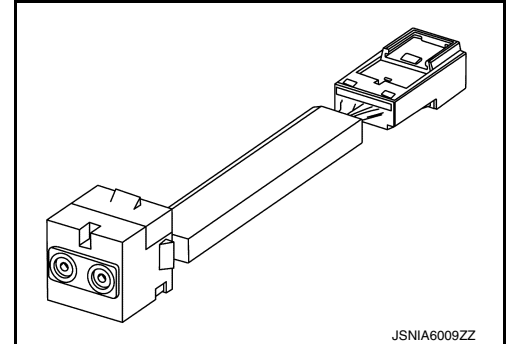

## Telematics Switch

INFOID:000000013717652

- The Telematics switch is located on the map lamp assembly.
- The Telematics switch is connected to TCU and transmits an operation signal.
- The state of LED (ON/Blink/OFF) shows the status of SOS call.

LED ON	:SOS Call available
LED Blink	:SOS Call in communication
LED OFF	:Out of service area or system error

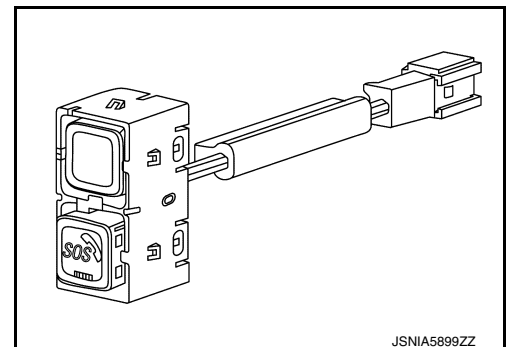

SYSTEM  
TELEMATICS SYSTEM

TELEMATICS SYSTEM : System Description

INFOID:000000013717653

SYSTEM DIAGRAM

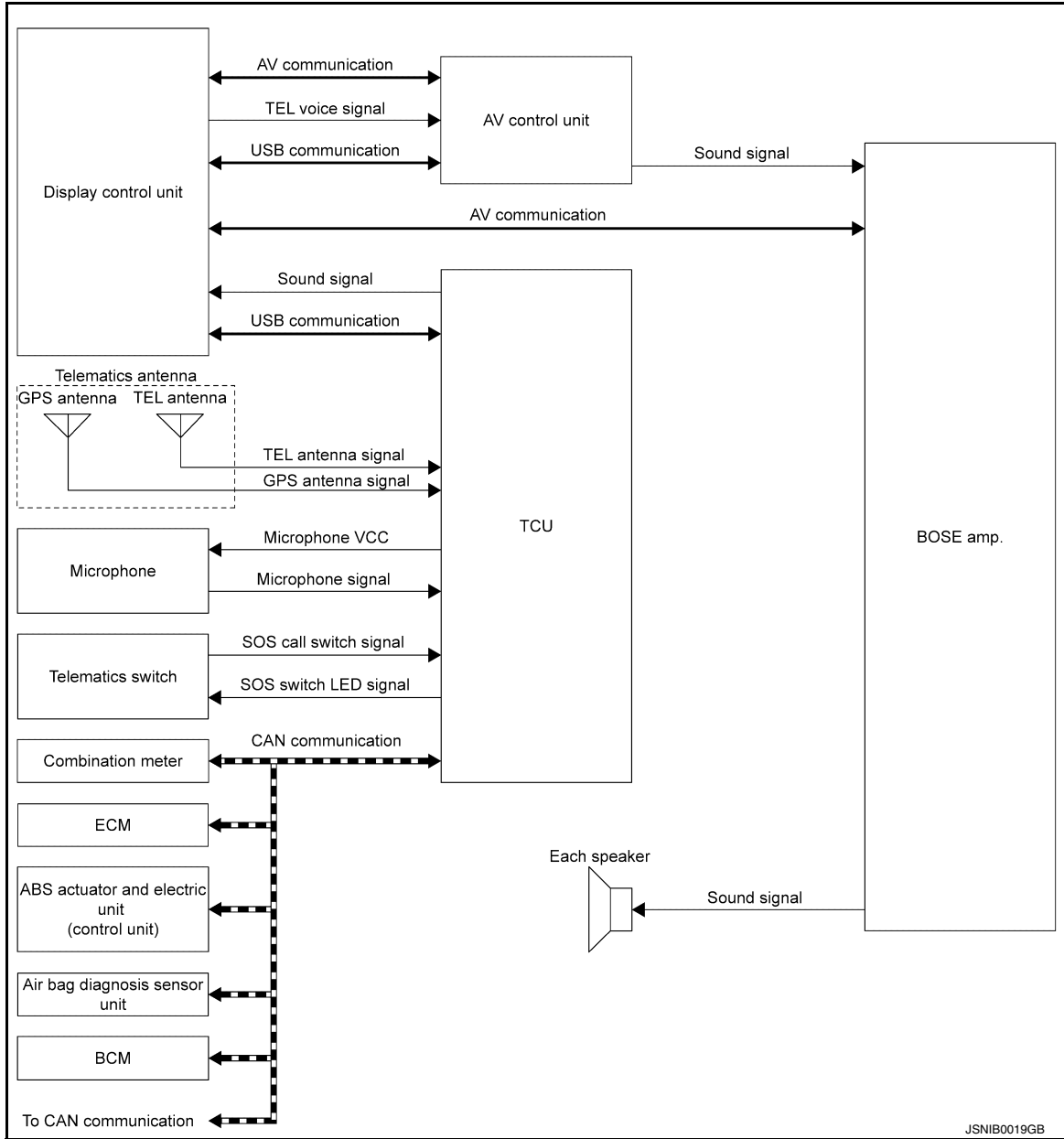

TCU Input Signal (CAN Communication)

Transmit unit	Signal name
ABS actuator and electric unit (control unit)	ABS warning lamp signal
	VDC warning lamp signal
Combination meter	Brake warning lamp signal
Airbag diagnosis sensor unit	Car crash information signal
BCM	Door lock status signal
	Trunk switch signal
	Oil pressure switch signal

A  
B  
C  
D  
E  
F  
G  
H  
I  
J  
K  
L  
M

AV

O  
P

# SYSTEM

< SYSTEM DESCRIPTION >

[TELEMATICS SYSTEM]

Transmit unit	Signal name
ECM	Malfunctioning indicator lamp signal
	Engine status signal

## DESCRIPTION

The adoption of the Telematics system allows the provision of information and services in real time for safe and pleasant driving.

- TCU (Telematics Communication Unit) equipped with a radio communication terminal communicates with the information center (Infiniti Connection™ Data Center) via radio waves for receiving Infiniti Connection™ services.
- In addition to the services received while driving, various kinds of vehicle information can be obtained via Infiniti Connection™ Data Center by using cell phone or personal computer.

The telematics system interacts with the Infiniti Connection™ Data Center using GPS and GSM/GPRS technologies. The telematics communication unit (TCU) can send messages to and receive commands from the Infiniti Connection™ Data Center. This allows the Infiniti Connection™ Data Center to monitor the vehicle and obtain actual position coordinates and automatically detected events, as well as initiate certain services from outside the vehicle. In addition, the vehicle operator can initiate services from inside the vehicle.

### NOTE:

For additional information on the Telematics system, refer to the NAVIGATION SYSTEM OWNER'S MANUAL.

## Infiniti Connection™ SERVICE

The user can transmit/receive various kinds of information via the information centers (Infiniti Connection™ Data Center).

- The available services are: Information service, Infiniti Connection™ Response service, shortest route search, safety & security service, etc. In addition, can remote-control a vehicle than a cell-phone using Infiniti Connection™ SERVICE. The details of the operation, refer to the following.
  - Remote door lock/unlock function: [DLK-17. "System Description"](#)
  - Remote panic alarm function: [SEC-27. "VEHICLE SECURITY SYSTEM : System Description"](#)
  - Remote engine start function: [SEC-27. "VEHICLE SECURITY SYSTEM : System Description"](#)
- The user can access Infiniti Connection™ user's homepage and check ECO drive information by using cell phone or personal computer.

# SYSTEM

< SYSTEM DESCRIPTION >

[TELEMATICS SYSTEM]

## TELEMATICS SYSTEM : Circuit Diagram

INFOID:000000013717654

VR30DDTT

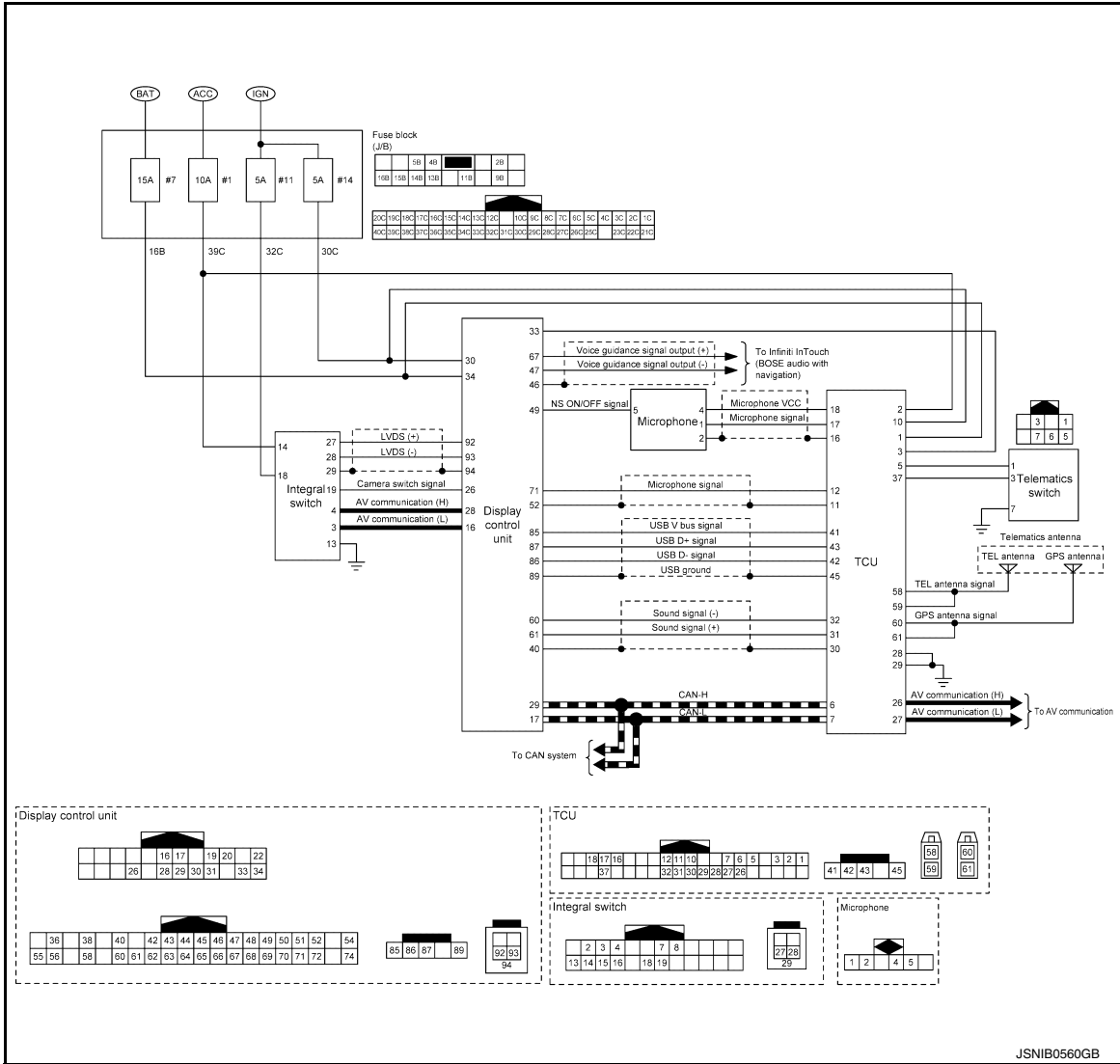

A  
B  
C  
D  
E  
F  
G  
H  
I  
J  
K  
L  
M

AV

## 2.0L TURBO GASOLINE ENGINE

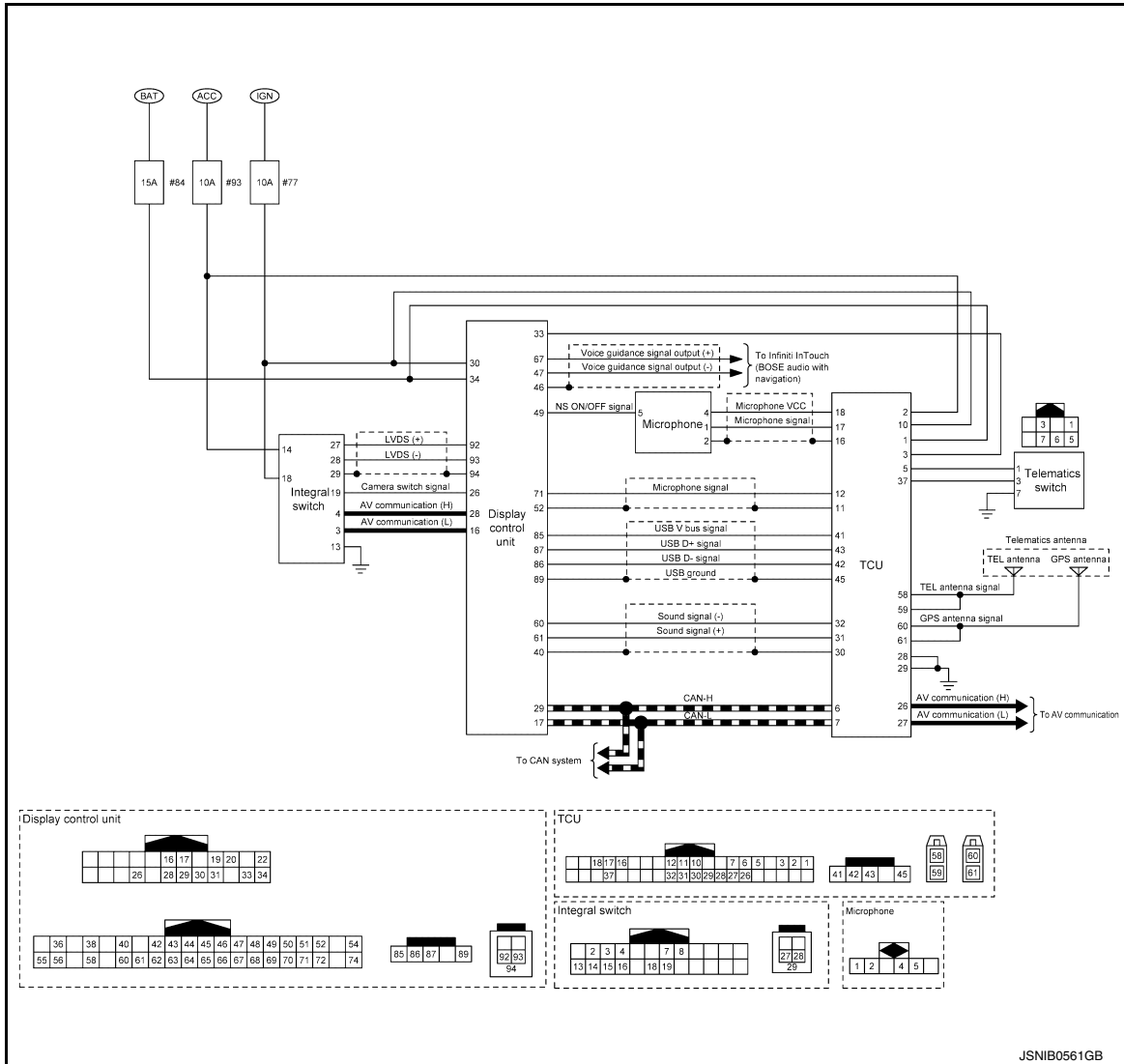

### TELEMATICS SYSTEM : Fail-safe

INFOID:000000014281914

If a malfunction occurs in the telematics system, TCU performs fail-safe activation according to the detected malfunction.

Detection item	Telematics system operation in fail-safe mode	DTC
Air-bag connection	Some telematics system does not function.	U1A10
CAN communication	Telematics system does not function.	U1000
AV communication	Some telematics system does not function.	B13E1
TEL antenna	Telematics switch LED indicator turn OFF. (LED indicator turns ON 10 times when push the SOS call switch.)	U1A06
GPS antenna	Telematics system cannot send correct positional information.	U1A09 U1A0A
USB communication	Telematics system does not function.	B13D9
TCU	Telematics system function stops.	B1310 B130D U1010 U1A01
	Telematics system function stops.	U1A03

# SYSTEM

< SYSTEM DESCRIPTION >

[TELEMATICS SYSTEM]

Detection item	Telematics system operation in fail-safe mode	DTC
Telematics switch (SOS call switch)	<ul style="list-style-type: none"><li>Telematics system does not function. (Only SOS call does not operate.)</li><li>Telematics switch LED indicator turn OFF.</li></ul>	B2E33 U1A0E
Microphone	Telematics service does not function.	U1A0B
	Transmit an own vehicle position to the INFINITI CONNECTION data center.	U1A0C
VIN	Telematics service does not function.	U1A04

A

B

C

D

E

F

G

H

I

J

K

L

M

AV

O

P

## HANDLING PRECAUTION

### Telematics

INFOID:000000013717656

- In the following cases, no Infiniti Connection™ services are available.
  - When the user has not subscribed to the service.
  - When the vehicle moves out of the radio receiving zone
  - When the radio wave reception environment is not suitable to data communication.
  - When the vehicle is in a location that may block radio waves such as in an underground parking lot, behind a building, and in mountainous areas.
- Because the voice exchange with the Infiniti Connection™ data center uses the data communication mode, the service area may be narrower and the connection availability may be worse than the normal telephone system.
- Communication and calls to the Infiniti Connection™ data center require additional charges.
- If the vehicle is outside the communication area of TCU or the radio wave reception condition is poor, the connection to the Infiniti Connection™ data center may not be available or interrupted.
- If the communication is interrupted during a data download through any of the available services, the data must be downloaded again from the beginning.
- When transferring your vehicle, always resign from your membership. For details about the cancellation procedure, contact the Infiniti Connection™ customer center.

## DIAGNOSIS SYSTEM (TCU)

### CONSULT Function

INFOID:000000013717657

#### APPLICATION ITEM

CONSULT performs the following items by communication with TCU:

Diagnosis mode	Description
Self-Diagnosis Result	Performs the diagnosis of TCU and displays the current and past malfunctions collectively.
Data Monitor	The diagnosis of the vehicle signal that is input to TCU can be performed.
Work support	Performs TCU activation setting and center connection setting.
ECU identification	Checks TCU part number and various ID numbers.
Configuration	<ul style="list-style-type: none"> <li>• The vehicle specification that is written in TCU can be displayed or stored</li> <li>• The vehicle specification can be written when TCU is replaced</li> </ul>

#### SELF-DIAGNOSIS RESULT

Refer to [AV-746, "DTC Index"](#).

- In CONSULT self-diagnosis, the self-diagnosis results and error history are displayed collectively.
- The current malfunction indicates "0". The counter increases by 1 if the condition is normal at the next power switch ON cycle.

#### DATA MONITOR

**NOTE:**

The following table includes information (items) inapplicable to this vehicle. For information (items) applicable to this vehicle, refer to CONSULT display items.

Display item	Display	Condition	Note
HF TYPE	NO BT	—	Indicates state of configuration result. <b>NOTE:</b> This item is displayed, but not used.
AUDIO UNIT TYPE	NAVI	—	
CALL SWITCH TYPE	SOS/OP	—	
SPEAKER TYPE	INDRCT	—	
ZONE	USA/CAN	—	
CHANNEL	INFINITI	—	
CAN COMM	GEN.3	—	
AV COMM	ENABLE/ DISABLE	—	
K-LINE	ENABLE/ DISABLE	—	
VEHICLE TYPE	ENG	—	
ECHO CANCEL	TYPE 1	—	This item is displayed, but cannot be monitored.
	TYPE 2		
	TYPE 3		
	TYPE 4		
NOISE CANCEL	TYPE 1	—	This item is displayed, but cannot be monitored.
	TYPE 2		
	TYPE 3		
	TYPE 4		
TCU STANDBY TIME	14DAYS	Set at 14 days (default)	Set value for continued operation time to control battery consumption
	2DAYS	Set at 2 days	
	30DAYS	Set at 30 days	
	NON	No setting	

# DIAGNOSIS SYSTEM (TCU)

< SYSTEM DESCRIPTION >

[TELEMATICS SYSTEM]

Display item	Display	Condition	Note
SENSOR ANGLE X	—	—	Indicates state of configuration result. <b>NOTE:</b> This item is displayed, but not used.
SENSOR ANGLE Y	—	—	
SENSOR ANGLE Z	—	—	
SVTB	—	—	
REMOTE DOOR LOCK	ENABLE/ DISABLE	—	
REMOTE HORN & LAMP	ENABLE/ DISABLE	—	
REMOTE START	ENABLE/ DISABLE	—	
NAD OUTPUT STATUS	On	When TCU activation is ON	NAD: Abbreviation of Network Access Device. ON/OFF setting of radio wave
	Off	When TCU activation is OFF	
ACN COMM SEQUENCE LOG	—	—	—
SOS COMM SEQUENCE LOG	—	—	—
SOS SWITCH	On	Telematics switch is ON	—
	Off	Telematics switch is OFF	

## WORK SUPPORT

Performs TCU activation setting and center connection setting.

Item name	Description
SAVE VIN DATA	The VIN data saved in TCU is stored in CONSULT.
TCU ACTIVATE SETTING	TCU ON/OFF setting is available.
WRITE VIN (SAVED DATA)	Write VIN data stored by "SAVE VIN DATA" in work support mode to TCU.
WRITE VIN (MANUAL INPUT)	Write VIN data in TCU. (MANUAL)

## ECU IDENTIFICATION

Displays TCU part number and various ID numbers.

Display items	Description
ECU PART NUMBER	Displays TCU part number.
UNIT ID	Displays display control unit ID number.
TCU ID	Displays TCU ID number.
SIM ID	Displays ICC ID of SIM card.
V.I.N	Displays the vehicle identification number stored in TCU.

## CONFIGURATION

Configuration includes functions as follows.

Function	Description	
Read/Write Configuration	Before ECU Replacement	Allows the reading of vehicle specification written in TCU to store the specification in CONSULT.
	After ECU Replacement	Allows the writing of the vehicle information stored in CONSULT into the TCU.
Manual Configuration	Allows the writing of the vehicle specification into the TCU by hand.	

## ECU DIAGNOSIS INFORMATION

## TCU

## Reference Value

INFOID:0000000013717658

## VALUES ON THE DIAGNOSIS TOOL

**NOTE:**

The following table includes information (items) inapplicable to this vehicle. For information (items) applicable to this vehicle, refer to CONSULT display items.

Monitor Item	Condition	Value/Status
HF TYPE	Ignition switch ON	NO BT
AUDIO UNIT TYPE	Ignition switch ON	NAVI
CALL SWITCH TYPE	Ignition switch ON	SOS
SPEAKER TYPE	Ignition switch ON	INDRCT
ZONE	Ignition switch ON	USA
		CAN
CHANNEL	Ignition switch ON	INFINITI
CAN COMM	Ignition switch ON	GEN.3
AV COMM	Ignition switch ON	ENABLE
K-LINE	Ignition switch ON	DISABLE
VEHICLE TYPE	Ignition switch ON	ENG
ECHO CANCEL	Ignition switch ON	TYPE2
NOISE CANCEL	Ignition switch ON	TYPE2
TCU STANDBY TIME	Set at 14 days (default)	14DAYS
	Set at 2 days	2DAYS
	Set at 30 days	30DAYS
	No setting	NON
SENSOR ANGLE X	Ignition switch ON	0.0
SENSOR ANGLE Y	Ignition switch ON	0.0
SENSOR ANGLE Z	Ignition switch ON	0.0
SVTB	Ignition switch ON	DISABLE
REMOTE DOOR LOCK	Ignition switch ON	DISABLE
REMOTE HORN & LAMP	Ignition switch ON	DISABLE
REMOTE START	Ignition switch ON	DISABLE
NAD OUTPUT STATUS	When TCU activation is ON	On
	When TCU activation is OFF	Off
ACN COMM SEQUENCE LOG	—	—
SOS COMM SEQUENCE LOG	—	—
SOS SW	Press telematics switch	On
	Other than the above	Off

## TERMINAL LAYOUT

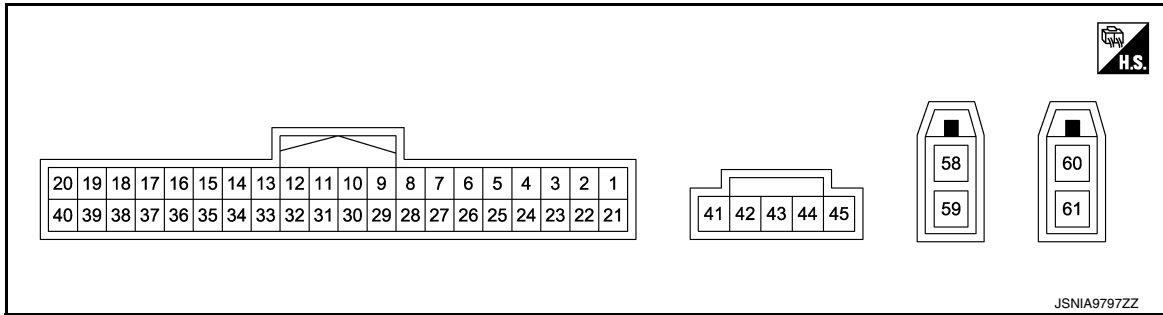

## PHYSICAL VALUES

Terminal (Wire color)		Description		Condition	Reference value (Approx.)
+	-	Signal name	Input/ Output		
1 (Y)	29 (B)	Battery power supply	Input	[Ignition switch OFF]	Battery Voltage
2 (SB) <sup>*1</sup> (V) <sup>*2</sup>	29 (B)	ACC power supply	Input	[Ignition switch ACC]	12.0 V
3 (SB)	29 (B)	ACC output	Output	[Ignition switch ACC]	12.0 V
5 (BR)	28 (B)	SOS switch LED signal	Input	[Ignition switch ACC] • When not illuminated LED lamp of SOS switch	12.0 V
				[Ignition switch ACC] • When illuminated LED lamp of SOS switch	0 V
6 (L)	—	CAN-H	Input/ Output	—	—
7 (P)	—	CAN-L	Input/ Output	—	—
10 (W) <sup>*1</sup> (R) <sup>*2</sup>	29 (B)	Ignition signal	Input	[Ignition switch ON]	12.0 V
11	—	Microphone signal ground	—	—	—
12 (R)	11	Microphone signal	Output	[Ignition switch ACC] • When inputting interior sound	 SKIB3609E
16	—	Shield	—	—	—
17 (G)	16	Microphone signal	Input	[Ignition switch ACC] • When inputting interior sound	 SKIB3609E

# TCU

< ECU DIAGNOSIS INFORMATION >

[TELEMATICS SYSTEM]

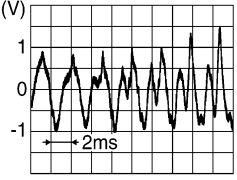
Terminal (Wire color)		Description		Condition	Reference value (Approx.)
+	-	Signal name	Input/ Output		
18 (L)	16	Microphone VCC	Input	[Ignition switch ACC]	5.0 V
26 (SB)	—	AV communication (H)	Input/ Output	—	—
27 (LG)	—	AV communication (L)	Input/ Output	—	—
28 (B)	Ground	Ground	—	[Ignition switch ON]	0 V
29 (B)	Ground	Ground	—	[Ignition switch ON]	0 V
30	—	Shield	—	—	—
31 (B)	32 (W)	Sound signal (+)	Output	[Ignition switch ACC] • When inputting interior sound	 <small>SKIB3609E</small>
32 (W)	—	Sound signal (-)	—	—	—
37 (G)	28 (B)	SOS call switch signal	Input	[Ignition switch ACC] • When pressing SOS switch	0 V
				[Ignition switch ACC] • Except for above	5.0 V
41 (R)	—	USB V BUS signal	—	—	—
42 (P)	—	USB D- signal	—	—	—
43 (W)	—	USB D+ signal	—	—	—
45	—	USB ground	—	—	—
58	—	TEL antenna signal	Input	Not connected TEL antenna connector.	5.0 V
59	—	Shield	—	—	—
60	—	GPS antenna signal	Input	Not connected GPS antenna connector.	5.0 V
61	—	Shield	—	—	—

\*1: 2.0L turbo gasoline engine models

\*2: VR30DDTT engine models

## Fail-safe

INFOID:000000013717659

If a malfunction occurs in the telematics system, TCU performs fail-safe activation according to the detected malfunction.

Detection item	Telematics system operation in fail-safe mode	DTC
Air-bag connection	Some telematics system does not function.	U1A10
CAN communication	Telematics system does not function.	U1000
AV communication	Some telematics system does not function.	B13E1

# TCU

< ECU DIAGNOSIS INFORMATION >

[TELEMATICS SYSTEM]

Detection item	Telematics system operation in fail-safe mode	DTC
TEL antenna	Telematics switch LED indicator turn OFF. (LED indicator turns ON 10 times when push the SOS call switch.)	U1A06
GPS antenna	Telematics system cannot send correct positional information.	U1A09 U1A0A
USB communication	Telematics system does not function.	B13D9
TCU	Telematics system function stops.	B1310 B130D U1010 U1A01
	Telematics system function stops.	U1A03
Telematics switch (SOS call switch)	<ul style="list-style-type: none"> <li>Telematics system does not function. (Only SOS call does not operate.)</li> <li>Telematics switch LED indicator turn OFF.</li> </ul>	B2E33 U1A0E
Microphone	Telematics service does not function.	U1A0B
	Transmit an own vehicle position to the INFINITI CONNECTION data center.	U1A0C
VIN	Telematics service does not function.	U1A04

## DTC Inspection Priority Chart

INFOID:0000000013717660

If multiple DTCs are detected simultaneously, check them one by one depending on the following DTC inspection priority chart.

Priority	Detected items (DTC)
1	U1A04: VIN UNFINISHED
2	<ul style="list-style-type: none"> <li>U1000: CAN COMM CIRCUIT</li> <li>U1010: CONTROL UNIT (CAN)</li> </ul>
3	<ul style="list-style-type: none"> <li>B130D: TEL LINE OUT ERROR</li> <li>B1310: TCU TEMPERATURE ERROR</li> <li>B13D9: USB CONNECTION</li> <li>B13E1: CAN COMMUNICATION</li> <li>B2E33: ECALL BUTTON</li> <li>U1A00: ACC NO CONN</li> <li>U1A01: INTERNAL ERROR (TCU)</li> <li>U1A03: SIM CARD</li> <li>U1A06: TEL ANTENNA</li> <li>U1A09: GPS ANTENNA CONN</li> <li>U1A0A: GPS MODULE COMM</li> <li>U1A0B: MIC IN CONN</li> <li>U1A0C: MIC OUT CONN</li> <li>U1A0E: SOS SWITCH ON STUCK</li> <li>U1A10: AIRBAG SIGNAL</li> </ul>

## DTC Index

INFOID:0000000013717661

DTC	Display contents of CONSULT	Reference
B130D	TEL LINE OUT ERROR	<a href="#">AV-770, "DTC Description"</a>
B1310	TCU TEMPERATURE ERROR	<a href="#">AV-772, "DTC Description"</a>
B13D9	USB CONNECTION	<a href="#">AV-773, "DTC Description"</a>
B13E1	CAN COMMUNICATION	<a href="#">AV-774, "DTC Description"</a>
B2E33	ECALL BUTTON	<a href="#">AV-775, "DTC Description"</a>
U1000	CAN COMM CIRCUIT	<a href="#">AV-777, "DTC Description"</a>
U1010	CONTROL UNIT (CAN)	<a href="#">AV-778, "DTC Description"</a>
U1A00	ACC NO CONN	<a href="#">AV-779, "DTC Description"</a>
U1A01	INTERNAL ERROR (TCU)	<a href="#">AV-780, "DTC Description"</a>

# TCU

< ECU DIAGNOSIS INFORMATION >

[TELEMATICS SYSTEM]

DTC	Display contents of CONSULT	Reference
U1A03	SIM CARD	<a href="#">AV-781, "DTC Description"</a>
U1A04	VIN UNFINISHED	<a href="#">AV-782, "DTC Description"</a>
U1A06	TEL ANTENNA	<a href="#">AV-783, "DTC Description"</a>
U1A09	GPS ANTENNA CONN	<a href="#">AV-784, "DTC Description"</a>
U1A0A	GPS MODULE COMM	<a href="#">AV-785, "DTC Description"</a>
U1A0B	MIC IN CONN	<a href="#">AV-786, "DTC Description"</a>
U1A0C	MIC OUT CONN	<a href="#">AV-788, "DTC Description"</a>
U1A0E	SOS SWITCH ON STUCK	<a href="#">AV-790, "DTC Description"</a>
U1A10	AIR BAG SIGNAL	<a href="#">AV-792, "DTC Description"</a>

A  
B  
C  
D  
E  
F  
G  
H  
I  
J  
K  
L  
M  
O  
P

AV

# WIRING DIAGRAM

## TELEMATICS SYSTEM

### Wiring Diagram

INFOID:000000013717662

### 2.0L TURBO GASOLINE

#### TELEMATICS SYSTEM (2.0L TURBO GASOLINE ENGINE)

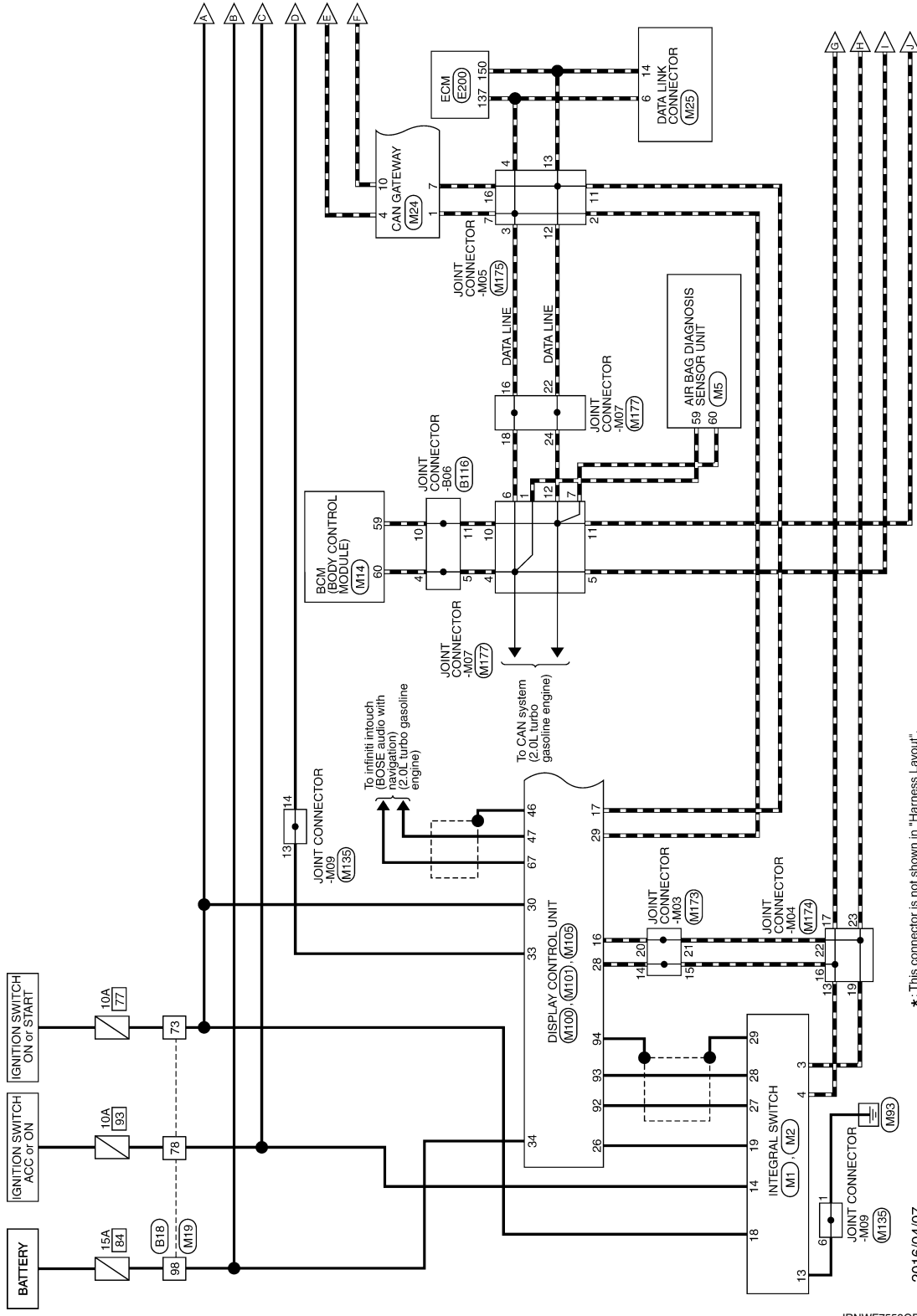

\*: This connector is not shown in "Harness Layout".

2016/04/07

JRNWF7558GB

# TELEMATICS SYSTEM

< WIRING DIAGRAM >

[TELEMATICS SYSTEM]

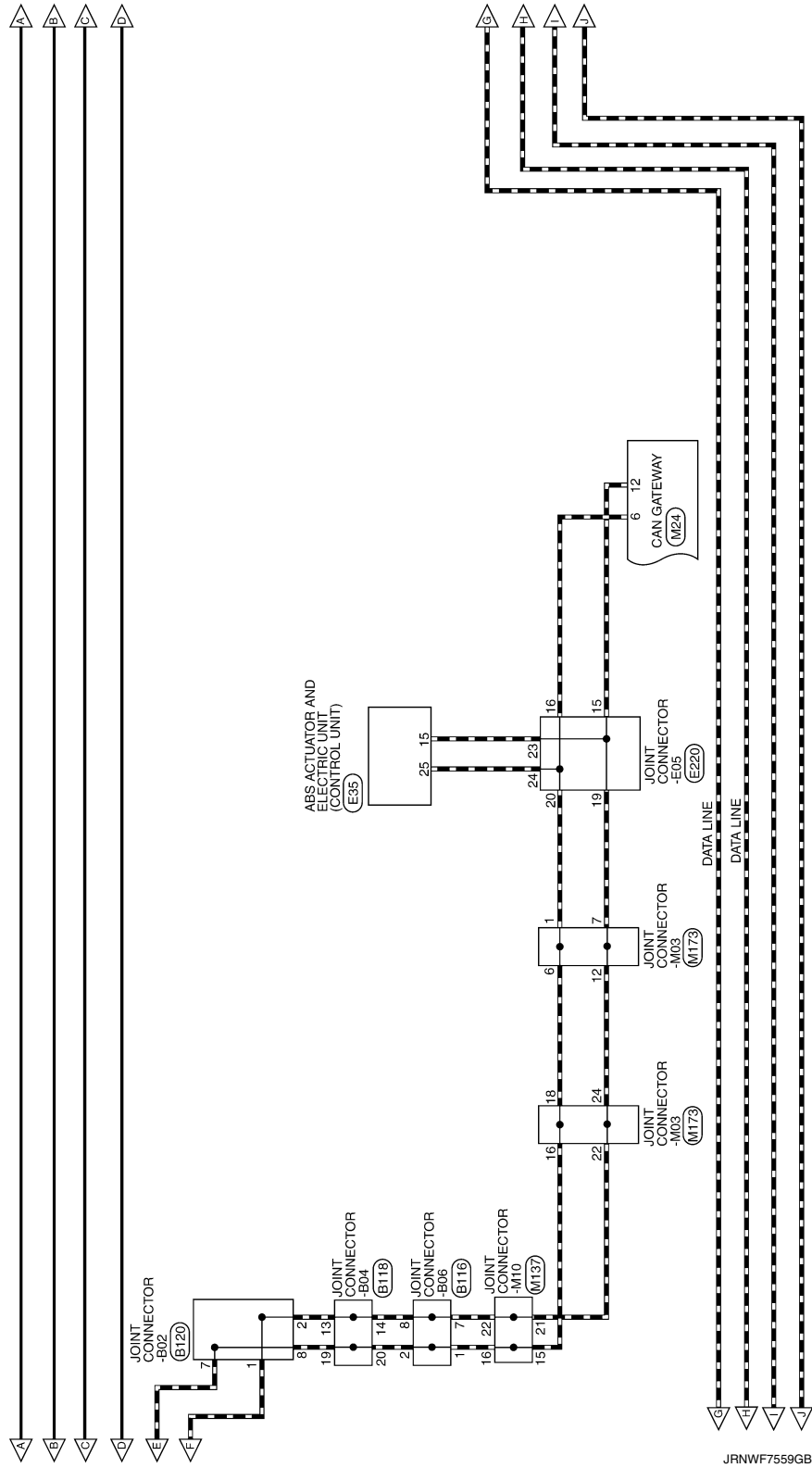

JRNWF7559GB

A  
B  
C  
D  
E  
F  
G  
H  
I  
J  
K  
L  
M  
AV  
O  
P

# TELEMATICS SYSTEM

< WIRING DIAGRAM >

[TELEMATICS SYSTEM]

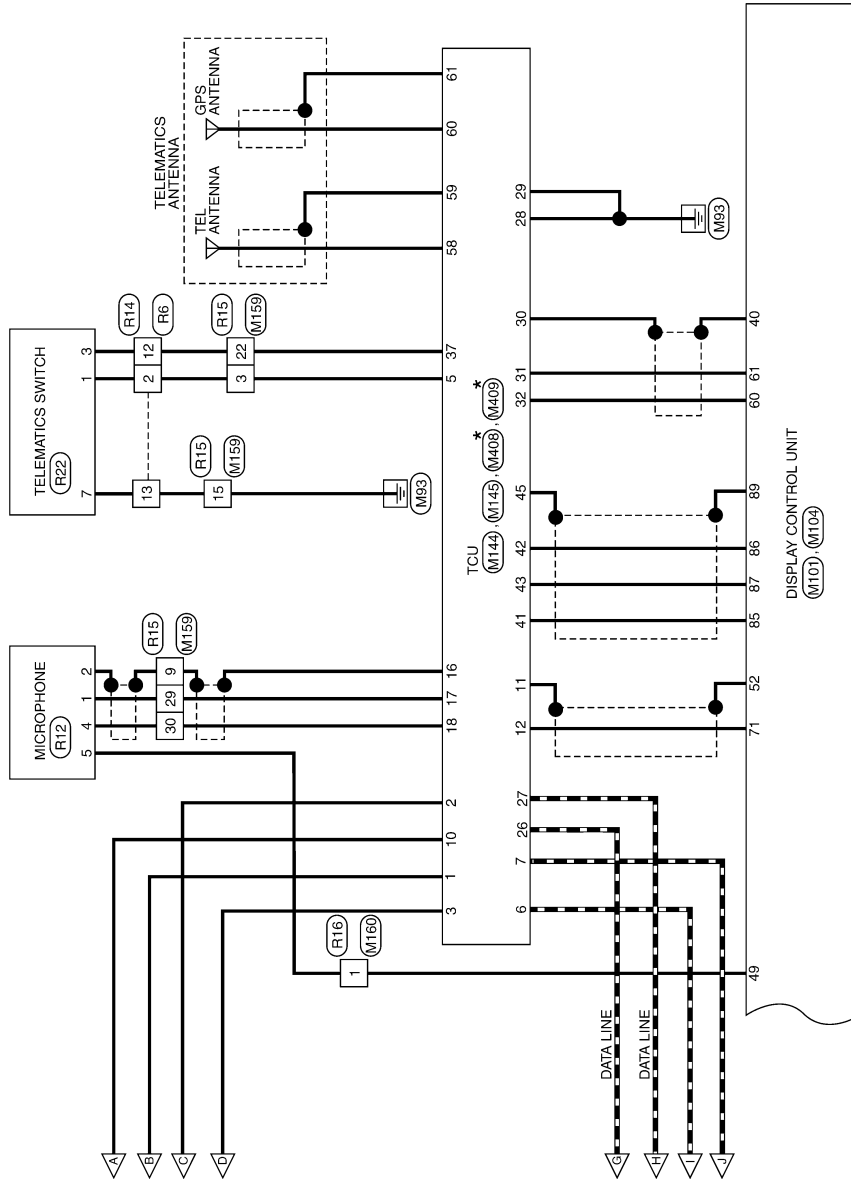

JRNWF7560GB

## TELEMATICS SYSTEM (2.0L TURBO GASOLINE ENGINE)

Connector No.	B18
Connector Name	WIRE TO WIRE
Connector Type	TH80FW-CS16-TM4

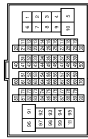

Terminal No.	Color Of Wire	Signal Name (Specification)
1	Y	-
2	G	-
3	L	-
5	Y	-
7	V	-
10	BG	-
11	BG	-
12	LG	-
13	GR	-
14	R	-
15	L	-
16	V	-
18	W	-
19	BR	-
20	W	-
22	R	-
23	V	-
24	R	- [With 2.0L turbo gasoline engine]
24	Y	- [With VR30 engine]
25	V	- [With 2.0L turbo gasoline engine]
25	W	- [With VR30 engine]
26	G	-
27	R	-
28	R	-
31	B	- [With VR30 engine]
31	BR	- [With 2.0L turbo gasoline engine]
32	B	-
33	B	-
34	LG	-
35	P	-
36	W	-
37	SB	-
38	LG	-
40	P	-
41	SB	-

42	BR	-
43	BG	-
44	BG	-
46	R	-
50	W	-
51	SB	-
52	V	-
53	LG	-
54	R	-
55	R	-
58	V	-
59	GR	-
60	G	-
61	G	-
62	BG	-
63	BR	-
64	Y	-
66	R	-
70	R	-
71	W	-
72	B	-
73	W	-
74	L	-
75	R	-
76	BR	-
77	B	-
78	SB	-
79	W	-
81	B	-
82	R	-
83	BG	-
84	L	-
85	R	-
86	B	-
88	G	-
89	V	-
91	GR	-
92	GR	-
93	GR	-
94	GR	-
96	Y	-
98	BR	- [With VR30 engine and with BOSE system]
98	Y	- [Except with VR30 engine and with BOSE system]

Connector No.	B116
Connector Name	JOINT CONNECTOR-B06
Connector Type	24342_4GA2A

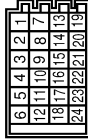

Terminal No.	Color Of Wire	Signal Name (Specification)
1	L	-
2	L	-
3	L	-
4	L	-
5	L	-
6	L	-
7	R	-
8	R	-
8	V	- [With Gateway]
9	R	- [Without Gateway]
9	V	- [With Gateway]
10	V	- [Without Gateway]
11	V	-
12	P	- [With 2.0L turbo gasoline engine]
12	R	- [With VR30 engine]
13	SHIELD	-
14	SHIELD	-
15	SHIELD	-
16	SHIELD	-
17	SHIELD	-
18	SHIELD	-
19	L	-
20	L	-
21	L	-
22	R	-
23	R	-
24	R	-

Connector No.	B118
Connector Name	JOINT CONNECTOR-B04
Connector Type	24342_4GA2A

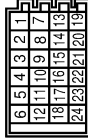

Terminal No.	Color Of Wire	Signal Name (Specification)
1	LG	- [With VR30 engine]
1	SHIELD	- [With 2.0L turbo gasoline engine]
2	LG	- [With VR30 engine]
2	SHIELD	- [With 2.0L turbo gasoline engine]
3	LG	- [With VR30 engine]
3	SHIELD	- [With 2.0L turbo gasoline engine]
4	LG	- [With VR30 engine]
4	SHIELD	- [With 2.0L turbo gasoline engine]
5	LG	- [With VR30 engine]
5	SHIELD	- [With 2.0L turbo gasoline engine]
6	LG	- [With VR30 engine]
6	SHIELD	- [With 2.0L turbo gasoline engine]
7	LG	- [With 2.0L turbo gasoline engine]
7	R	- [With VR30 engine]
8	R	-
9	LG	- [With 2.0L turbo gasoline engine]
9	R	- [With VR30 engine]
10	LG	- [With 2.0L turbo gasoline engine]
10	SHIELD	- [With VR30 engine]
11	LG	- [With 2.0L turbo gasoline engine]
11	SHIELD	- [With VR30 engine]
12	LG	- [With 2.0L turbo gasoline engine]
12	SHIELD	- [With VR30 engine]
13	L	- [With VR30 engine]
13	R	- [With 2.0L turbo gasoline engine]
14	L	- [With VR30 engine]
14	R	- [With 2.0L turbo gasoline engine]
15	L	- [With VR30 engine]
15	R	- [With 2.0L turbo gasoline engine]
16	L	-
17	L	-
18	L	-
19	L	- [With 2.0L turbo gasoline engine]
19	SHIELD	- [With VR30 engine]
20	L	- [With 2.0L turbo gasoline engine]

A  
B  
C  
D  
E  
F  
G  
H  
I  
J  
K  
L  
M  
N  
O  
P

AV

## TELEMATICS SYSTEM (2.0L TURBO GASOLINE ENGINE)

20	SHIELD	- [With VR30 engine]
21	L	- [With 2.0L turbo gasoline engine]
22	R	- [With VR30 engine]
23	R	-
24	R	-

Connector No.	8120
Connector Name	JOINT CONNECTOR-B02
Connector Type	24342-4G62A



Terminal No.	Color Of Wire	Signal Name [Specification]
1	R	-
2	R	-
3	L	- [With VR30 engine]
4	L	- [With 2.0L turbo gasoline engine]
5	L	- [With VR30 engine]
6	L	- [With 2.0L turbo gasoline engine]
7	L	-
8	L	- [With 2.0L turbo gasoline engine]
9	R	- [With VR30 engine]
10	L	- [With 2.0L turbo gasoline engine]
11	R	- [With VR30 engine]
12	R	-
13	W	-
14	W	-
15	W	-
17	SHIELD	-
18	B	- [With 2.0L turbo gasoline engine]
19	GR	- [With VR30 engine]
20	GR	- [With VR30 engine]
21	B	- [With 2.0L turbo gasoline engine]
22	W	- [With VR30 engine]

23	W	-
24	W	-

Connector No.	E35
Connector Name	ABS ACTUATOR AND ELECTRICAL CONTROL UNIT
Connector Type	SAZ30FB-S1Z-U

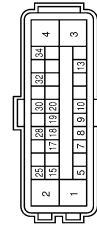

Terminal No.	Color Of Wire	Signal Name [Specification]
1	B	GROUND
2	B	GROUND
3	G	VALVE BATTERY [With VR30 engine]
4	P	VALVE BATTERY [With 2.0L turbo gasoline engine]
5	Y	MOTOR BATTERY
6	Y	STOP LAMP SW SIGNAL [With ADAS]
7	V	STOP LAMP SW SIGNAL [With ASCD]
8	GR	RR LH WHEEL SENSOR SIGNAL
9	G	RR LH WHEEL SENSOR POWER SUPPLY
10	GR	FR RH WHEEL SENSOR SIGNAL
11	R	FR RH WHEEL SENSOR POWER SUPPLY
12	R	VACUUM SENSOR SIGNAL
13	R	CAN-L [Without Gateway]
14	P	CAN-L [With Gateway]
15	R	RR RH WHEEL SENSOR SIGNAL
16	Y	RR RH WHEEL SENSOR POWER SUPPLY [With 2.0L turbo gasoline engine]
17	Y	RR RH WHEEL SENSOR POWER SUPPLY [With VR30 engine]
18	V	FR LH WHEEL SENSOR SIGNAL
19	SB	FR LH WHEEL SENSOR POWER SUPPLY
20	BG	FR LH WHEEL SENSOR POWER SUPPLY
21	L	CAN-H
22	G	VACUUM SENSOR POWER SUPPLY
23	G	VDC OFF SW SIGNAL
24	SHIELD	VACUUM SENSOR GROUND
25	G	IGN
34	G	IGN

Connector No.	EZ00
Connector Name	ECM
Connector Type	ADA52FB-AH26



Terminal No.	Color Of Wire	Signal Name [Specification]
97	G	POWER SUPPLY (MAIN)
98	B	ECM GROUND
99	G	POWER SUPPLY (MAIN)
100	B	ECM GROUND
101	G	POWER SUPPLY (MAIN)
102	B	ECM GROUND
103	V	COOLING FAN CONTROL SIGNAL (PWM)
104	Y	SENSOR POWER SUPPLY
105	R	SENSOR POWER SUPPLY
106	W	SENSOR GROUND
109	P	ENGINE SPEED SIGNAL
111	G	POWER SUPPLY
116	LG	STARTER RELAY-L
119	BR	SENSOR GROUND
120	BG	SENSOR GROUND
123	BR	MAIN RELAY CONTROL SIGNAL
127	V	FUEL PUMP ON SIGNAL
132	G	ACCELERATOR PEDAL POSITION SENSOR 1
137	L	CAN-H
138	L	DRIVE TRAIN CAN-H
142	GR	BACK-UP LAMP SWITCH
143	LG	REFRIGERANT PRESSURE SENSOR
145	L	ACCELERATOR PEDAL POSITION SENSOR 2
146	L	FUEL TANK PRESSURE SENSOR
148	L	THROTTLE CONTROL MOTOR (CLOSE) (BANK 2)
150	P	CAN-L
151	P	DRIVE TRAIN CAN-L
152	B	EVAP CANISTER VENT CONTROL VALVE
153	G	EVAP PURGE CONTROL VALVE

Connector No.	EZ20
Connector Name	JOINT CONNECTOR-E05
Connector Type	NH24FB-J



Terminal No.	Color Of Wire	Signal Name [Specification]
3	W	-
4	L	-
7	W	-
8	L	-
15	R	-
16	L	-
19	R	-
20	L	-
23	R	-
24	L	-

Connector No.	M1
Connector Name	INTEGRAL SWITCH
Connector Type	TH24FW-NH

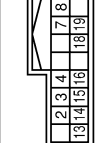

Terminal No.	Color Of Wire	Signal Name [Specification]
2	R	ILLUMINATION SIGNAL
3	LG	AV COMMUNICATION SIGNAL (L)
4	SB	AV COMMUNICATION SIGNAL (H)
7	W/B	DISK EJECT SIGNAL
8	G	HAZARD SIGNAL
13	B	GROUND
14	SB	ACC POWER SUPPLY [With 2.0L turbo gasoline engine]
15	V	ACC POWER SUPPLY [With VR30 engine]
16	B	ILLUMINATION CONTROL SIGNAL
16	BG	DISK EJECT SIGNAL GROUND

## TELEMATICS SYSTEM (2.0L TURBO GASOLINE ENGINE)

18	R	IGNITION SIGNAL (With VR30 engine)
18	W	IGNITION SIGNAL (With 2.0L turbo gasoline engine)
19	BR	CAMERA SWITCH SIGNAL

Connector No.	M12
Connector Name	INTEGRAL SWITCH
Connector Type	Type_15549872.6



Terminal No.	Color Of Wire	Signal Name [Specification]
27	W	LVDS (+)
28	B	LVDS (-)
29	SHIELD	SHIELD

Connector No.	M15
Connector Name	AIR BAG DIAGNOSIS SENSOR UNIT
Connector Type	NH28FY-EX



Terminal No.	Color Of Wire	Signal Name [Specification]
1	LG	IGN
2	B	GND
3	Y/R	DR1 (+)
4	Y/B	DR1 (-)
5	Y	DR2 (+)
6	Y/R	AS1 (+)
7	Y/B	AS1 (-)
8	Y/G	AS2 (+)
9	Y	AS2 (-)
18	Y	ECZ5 (+)
19	BR	ECZ5 (-)
20	Y/R	ACT VENT (+)

21	Y/B	ACT VENT (-)
22	SHIELD	GND
23	V	AIRBAG W/L
24	G	
25	GR	A/B OFF IND
51	G	SATELLITE RH2 (+)
52	R	SIDE SENS RH2 (-)
53	V	SIDE SENS LH2 (+)
54	Y	SIDE SENS LH2 (-)
57	LG	LUCS
59	L	CAN-H
60	P	CAN-L

Connector No.	M14
Connector Name	BCM (BODY CONTROL MODULE)
Connector Type	TH40FF-NH



Terminal No.	Color Of Wire	Signal Name [Specification]
48	R	PUSH-BTN IGN SW (L/PWR)
52	G	DONGLE LINK
54	V	COMM LINE
55	R	RAIN SENSOR
59	P	CAN-L
60	L	CAN-H
61	G	REAR WINDOW DEF RLY CONT
62	R	STARTER RLY CONT
64	V	LAKEY WARN BUZZER
65	B	OUTS HD AMPR CONT
66	B	BLOWER FAN RLY CONT (With VR30 engine)
66	Y	Blower Fan Rly Cont (With 2.0L turbo gasoline engine)
67	W/B	IGN RLY (F/B) CONT
68	R	DIMMER
69	GR	A/T SHFT SELECT PWR SPKY
70	B	IGN RELAY (PDM/E/R) CONT
71	G	DR DOOR REQ SW
72	SB	PASS DOOR REQ SW
75	BR	COMBI SW INPUT 5
76	BG	COMBI SW INPUT 4
77	V	COMBI SW INPUT 3
78	Y	COMBI SW INPUT 2

79	LG	COMBI SW INPUT 1
80	L	TR LID OPNR SW

Connector No.	M19
Connector Name	WIRE TO WIRE
Connector Type	TH80MW-CS16-TM4



Terminal No.	Color Of Wire	Signal Name [Specification]
1	Y	
2	G	
3	S/B	
5	Y	
7	W	
10	BG	
11	BR	
12	LG	
13	GR	
14	R	
15	L	
16	V	
18	W	
19	BR	
20	W	
24	R	- [With 2.0L turbo gasoline engine]
24	P	- [With VR30 engine]
25	W	- [With 2.0L turbo gasoline engine]
25	W	- [With VR30 engine]
26	G	
27	R	
28	R	
31	BR	
32	B	
33	B	
34	V	
35	P	
36	W	
37	S/B	
38	LG	
40	P	
41	G	

42	BR	
43	BR	
44	BR	
46	BG	
50	W	
51	Y	
52	V	
53	LG	
54	R	
55	R	
58	V	
59	BG	
60	G	
61	G	
62	BG	
63	BR	
64	Y	
66	R	
70	LG	
71	W	
72	B	
73	W	
74	L	
75	W	
76	BR	
77	B	
78	S/B	
79	W	
81	B	
82	R	
83	BG	
84	L	
85	W	
86	B	
88	G	
89	V	
91	GR	
93	GR	
94	GR	
96	W	
98	BR	- [With VR30 engine and with BOSE system]
98	Y	- [Except with VR30 engine and with BOSE system]

A  
B  
C  
D  
E  
F  
G  
H  
I  
J  
K  
L  
M  
N  
O  
P

AV

## TELEMATICS SYSTEM (2.0L TURBO GASOLINE ENGINE)

Connector No.	M24
Connector Name	CAN GATEWAY
Connector Type	TH12FW-NH

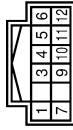

Terminal No.	Color Of Wire	Signal Name [Specification]
1	L	CAN-H (CAN COMMUNICATION CIRCUIT 1)
3	W	BATTERY POWER SUPPLY
4	L	CAN-H (CAN COMMUNICATION CIRCUIT 2)
5	B	GROUND
6	L	CAN-H (CAN COMMUNICATION CIRCUIT 2)
7	P	CAN-L (CAN COMMUNICATION CIRCUIT 1)
9	R	IGNITION POWER SUPPLY (With VRS0 engine)
9	W	IGNITION POWER SUPPLY (With 2.0L turbo gasoline engine)
10	R	CAN-L (CAN COMMUNICATION CIRCUIT 2)
11	B	GROUND
12	R	CAN-L (CAN COMMUNICATION CIRCUIT 2)

Connector No.	M25
Connector Name	DATA LINK CONNECTOR
Connector Type	BD16FW

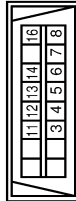

Terminal No.	Color Of Wire	Signal Name [Specification]
3	LG	M-CAN-L
4	B	EARTH
5	B	EARTH
6	L	CAN-H
7	V	KLIVE [With 2.0L turbo gasoline engine]
8	W	IGN-SW
11	SB	M-CAN-H
12	R	CAN-L

Terminal No.	13	L	CAN-H
	14	P	CAN-L
	16	W	POWER

Connector No.	M100
Connector Name	DISPLAY CONTROL UNIT
Connector Type	TH24FW-NH

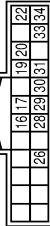

Terminal No.	Color Of Wire	Signal Name [Specification]
16	LG	AV COMMUNICATION SIGNAL (L)
17	P	CAN-L
19	R	DIMMER SIGNAL
20	BR	REVERSE SIGNAL
22	B	GROUND
26	BR	CAMERA SWITCH SIGNAL
28	SB	AV COMMUNICATION SIGNAL (H)
29	L	CAN-H
30	R	IGNITION SIGNAL (With VRS0 engine)
30	W	IGNITION SIGNAL (With 2.0L turbo gasoline engine)
31	R	VEHICLE SPEED SIGNAL (8-PULSE)
33	SB	ACC POWER SUPPLY
34	Y	BATTERY POWER SUPPLY

Connector No.	M101
Connector Name	DISPLAY CONTROL UNIT
Connector Type	TH40FW-NH



Terminal No.	Color Of Wire	Signal Name [Specification]
36	LG	COMPOSITE IMAGE SIGNAL (-)
38	SHIELD	SHIELD
40	SHIELD	MANUFACTURES SPECIFIC SIGNAL
42	G	SOUND SIGNAL RH (-)
43	SHIELD	SHIELD
44	L	SOUND SIGNAL LH (-)
45	W	TEL VOICE SIGNAL (-)
46	SHIELD	SHIELD
47	R	VOICE GUIDANCE SIGNAL OUTPUT (-)
48	B	VOICE GUIDANCE SIGNAL INPUT (-)
49	W	RS ON/OFF SIGNAL
50	R	MICROPHONE SIGNAL GROUND (With navigation)
51	SHIELD	SHIELD
52	SHIELD	MICROPHONE SIGNAL GROUND
54	W	CAMERA POWER SUPPLY GROUND
55	SHIELD	SHIELD
56	BR	COMPOSITE IMAGE SIGNAL (+)
58	B	CAMERA IMAGE SIGNAL
60	W	SOUND SIGNAL (-)
61	B	SOUND SIGNAL (+)
62	R	SOUND SIGNAL RH (+)
63	SHIELD	SHIELD
64	V	SOUND SIGNAL LH (+)
65	B	TEL VOICE SIGNAL (+)
66	SHIELD	SHIELD
67	G	VOICE GUIDANCE SIGNAL OUTPUT (+)
68	W	VOICE GUIDANCE SIGNAL INPUT (+)
69	SHIELD	SHIELD
70	G	MICROPHONE SIGNAL (NAVI)
71	G	MICROPHONE SIGNAL (Without telematics system)
71	R	MICROPHONE SIGNAL (With telematics system)
72	L	MICROPHONE VCC
74	R	CAMERA POWER SUPPLY

Connector No.	M104
Connector Name	DISPLAY CONTROL UNIT
Connector Type	USCAR30-MCF



Terminal No.	Color Of Wire	Signal Name [Specification]
85	R	USB V BUS SIGNAL
86	P	USB D+ SIGNAL
87	W	USB D- SIGNAL
89	SHIELD	USB GROUND

Connector No.	M105
Connector Name	DISPLAY CONTROL UNIT
Connector Type	Tyc_1554987-6



Terminal No.	Color Of Wire	Signal Name [Specification]
92	W	LWDS (+)
93	R	LWDS (-)
94	SHIELD	SHIELD

## TELEMATICS SYSTEM (2.0L TURBO GASOLINE ENGINE)

Connector No.	M135
Connector Name	JOINT CONNECTOR-M09
Connector Type	24342_4GAZA



Terminal No.	Color Of Wire	Signal Name [Specification]
1	B	-
2	B	-
3	B	-
4	B	-
5	B	-
6	B	-
9	LG	-
10	LG	-
11	LG	-
13	B	- [With VR30 engine]
13	SB	- [With 2.0L turbo gasoline engine]
14	B	- [With VR30 engine]
14	SB	- [With 2.0L turbo gasoline engine]
15	B	- [With VR30 engine]
15	SB	- [With 2.0L turbo gasoline engine]
16	Y	- [With VR30 engine]
17	SB	- [With 2.0L turbo gasoline engine]
18	SB	- [With VR30 engine]
18	Y	- [With 2.0L turbo gasoline engine]
19	SHIELD	- [With VR30 engine]
19	Y	- [With 2.0L turbo gasoline engine]
20	R	-
21	R	-
22	SHIELD	-
23	L	-
24	L	-

Connector No.	M137
Connector Name	JOINT CONNECTOR-M10
Connector Type	24342_4GAZA

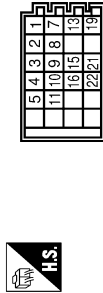

Terminal No.	Color Of Wire	Signal Name [Specification]
1	B	-
2	B	-
3	B	-
4	B	-
5	B	-
7	B	-
8	B	-
9	B	-
10	B	-
11	B	-
13	L	-
15	L	-
16	L	-
19	R	-
21	R	-
22	R	-

Connector No.	M144
Connector Name	TCU
Connector Type	TH40FB-NH

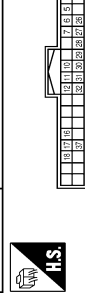

Terminal No.	Color Of Wire	Signal Name [Specification]
1	Y	BATTERY POWER SUPPLY
2	SB	ACC POWER SUPPLY [With 2.0L turbo gasoline engine]
2	V	ACC POWER SUPPLY [With VR30 engine]
3	SB	ACC OUTPUT

5	BR	SOS SWITCH-LED SIGNAL
6	L	CAN-H
7	P	CAN-L
10	R	IGNITION SIGNAL [With VR30 engine]
10	W	IGNITION SIGNAL [With 2.0L turbo gasoline engine]
11	SHIELD	MICROPHONE SIGNAL GROUND
12	R	MICROPHONE SIGNAL
16	SHIELD	SHIELD
17	G	MICROPHONE VCC
18	G	MICROPHONE VCC
26	SB	AV COMMUNICATION SIGNAL (H)
27	LG	AV COMMUNICATION SIGNAL (L)
28	B	GROUND
29	B	GROUND
30	SHIELD	SHIELD
31	B	SOUND SIGNAL (+)
32	W	SOUND SIGNAL (-)
37	G	SOS CALL SWITCH SIGNAL

Connector No.	M145
Connector Name	TCU
Connector Type	USCAR30-MC-F



Terminal No.	Color Of Wire	Signal Name [Specification]
41	R	USB V BUS SIGNAL
42	P	USB D+ SIGNAL
43	W	USB D- SIGNAL
45	SHIELD	USB GROUND

Connector No.	M159
Connector Name	WIRE TO WIRE
Connector Type	TH40FW-NH

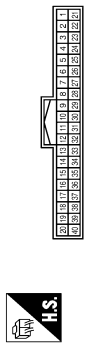

Terminal No.	Color Of Wire	Signal Name [Specification]
1	G	-
2	B	-
3	BR	-
4	R	-
5	GR	-
6	W	-
9	SHIELD	-
10	W	-
11	R	-
12	L	-
13	G	-
14	W	- [With VR30 engine]
14	Y	- [With 2.0L turbo gasoline engine]
15	B	-
17	B	-
19	R	-
20	BR	- [With VR30 engine and with BOSE system]
20	SB	- [With 2.0L turbo gasoline engine and without BOSE system]
21	R	-
22	G	-
24	B	-
25	W	-
26	R	-
28	B	-
29	G	-
30	L	-
31	R	-
32	W	-
33	L	-
35	V	-
38	LG	-
40	L	- [With 2.0L turbo gasoline engine and without BOSE system]
40	W	- [With 2.0L turbo gasoline engine and without BOSE system]

A  
B  
C  
D  
E  
F  
G  
H  
I  
J  
K  
L  
M  
N  
O  
P



### TELEMATICS SYSTEM (2.0L TURBO GASOLINE ENGINE)

Connector No.	M160
Connector Name	WIRE TO WIRE
Connector Type	NS08FW-CS



Terminal No.	Color Of Wire	Signal Name [Specification]
1	W	-
2	LG	-
3	BR	-
4	R	-
6	B	-
7	R	-
8	V	-

Connector No.	M173
Connector Name	JOINT CONNECTOR-M03
Connector Type	24342_4GAZA

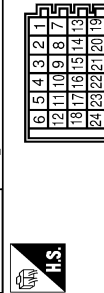

Terminal No.	Color Of Wire	Signal Name [Specification]
1	L	-
2	L	-
3	L	-
4	L	-
5	L	-
6	L	-
7	R	-
8	R	-
9	R	-
10	R	-
11	R	-
12	R	-
13	SB	-
14	SB	-
15	SB	-
16	SB	-
17	SB	-
18	SB	-
19	SB	-

14	SB	-
15	SB	-
16	L	- [With 2.0L turbo gasoline engine]
17	SB	- [With VFS30 engine]
18	L	- [With 2.0L turbo gasoline engine]
19	SB	- [With VFS30 engine]
20	BR	- [With 2.0L turbo gasoline engine]
21	BR	- [With VFS30 engine]
22	R	- [With 2.0L turbo gasoline engine]
23	SB	- [With VFS30 engine]
24	R	- [With 2.0L turbo gasoline engine]

Connector No.	M174
Connector Name	JOINT CONNECTOR-M04
Connector Type	24342_4GAZA

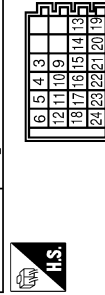

Terminal No.	Color Of Wire	Signal Name [Specification]
3	L	-
4	L	-
5	L	-
6	L	-
8	V	-
10	Y	-
11	Y	-
12	Y	-
13	SB	-
14	SB	-
15	SB	-
16	SB	-
17	SB	-
18	SB	-

19	LG	-
20	LG	-
21	LG	-
22	LG	-
23	LG	-
24	LG	-

Connector No.	M175
Connector Name	JOINT CONNECTOR-M05
Connector Type	NR20FL-DC

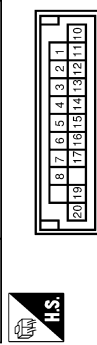

Terminal No.	Color Of Wire	Signal Name [Specification]
1	L	-
2	L	-
3	L	-
4	L	-
5	L	-
6	L	-
7	L	-
8	L	-
10	P	-
11	P	-
12	P	-
13	P	-
14	P	-
15	P	-
16	P	-
17	P	-
19	W	-
20	W	-

Connector No.	M177
Connector Name	JOINT CONNECTOR-M07
Connector Type	24342_4GAZA



Terminal No.	Color Of Wire	Signal Name [Specification]
1	L	-
3	L	-
4	L	-
5	L	-
6	L	-
7	P	-
9	P	-
10	P	-
11	P	-
12	P	-
16	L	-
17	L	-
18	L	-
22	P	-
23	P	-
24	P	-

Connector No.	M408
Connector Name	TCU
Connector Type	GT16C-1P-05

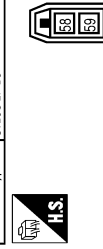

Terminal No.	Color Of Wire	Signal Name [Specification]
58	-	TEL ANTENNA SIGNAL
59	-	SHIELD

## TELEMATICS SYSTEM | 2.0L TURBO GASOLINE ENGINE

Connector No.	M409
Connector Name	TCU
Connector Type	GT16C-JP-05



Connector No.	R12
Connector Name	MICROPHONE
Connector Type	ANGFW

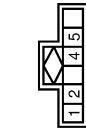

Connector No.	R15
Connector Name	WIRE TO WIRE
Connector Type	TH40WA-NH



Connector No.	R16
Connector Name	WIRE TO WIRE
Connector Type	NS98MW-CS



Terminal No.	Color Of Wire	Signal Name [Specification]
60	R	GPS ANTENNA SIGNAL
61	-	SHIELD

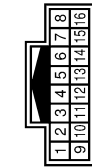

Connector No.	R6
Connector Name	WIRE TO WIRE
Connector Type	TH16MW-NH



Terminal No.	Color Of Wire	Signal Name [Specification]
1	R	-
2	SHIELD	-
4	L	-
5	W	-

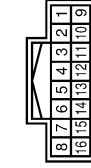

Connector No.	R4
Connector Name	WIRE TO WIRE
Connector Type	TH16FW-NH



Terminal No.	Color Of Wire	Signal Name [Specification]
1	G	-
2	LG	-
3	BR	-
4	V	-
5	BG	-
6	GR	-
9	SHIELD	-
10	GR	-
11	R	-
12	L	-
13	G	-
14	W	- [With VR30 engine]
14	Y	- [With 2.0L turbo gasoline engine]
15	B	-
17	SB	-
19	BG	-
20	BG	- [Without BOSE system]
20	BR	- [With BOSE system]
21	R	-
22	G	-
24	B	-
25	P	-
26	BR	-
28	B	-
29	R	-
30	L	-
31	V	-
32	W	-
33	L	-
36	BR	-
38	SB	-
40	W	-

Terminal No.	Color Of Wire	Signal Name [Specification]
1	BG	- [With VR30 engine]
1	SB	- [With 2.0L turbo gasoline engine]
2	BR	-
4	V	-
6	SB	-
7	R	-
8	G	-
9	L	- [With 2.0L turbo gasoline engine]
9	W	- [With VR30 engine]
11	LG	-
12	G	-
13	B	-

Terminal No.	Color Of Wire	Signal Name [Specification]
1	BG	- [With VR30 engine]
1	SB	- [With 2.0L turbo gasoline engine]
2	BR	-
4	V	-
6	SB	-
7	R	-
8	G	-
9	L	- [With 2.0L turbo gasoline engine]
9	W	- [With VR30 engine]
11	LG	-
12	G	-
13	B	-

Terminal No.	Color Of Wire	Signal Name [Specification]
1	W	-
2	R	-
3	Y	-
4	W	-
6	B	-
7	GR	-
8	V	-



Connector No.	R22
Connector Name	TELEMATICS SWITCH
Connector Type	TH08FW-NH



Terminal No.	Color Of Wire	Signal Name [Specification]
1	V	-
3	G	-
5	SB	-
6	B	-
7	B	-

A  
B  
C  
D  
E  
F  
G  
H  
I  
J  
K  
L  
M  
N  
O  
P

AV

# TELEMATICS SYSTEM

< WIRING DIAGRAM >

[TELEMATICS SYSTEM]

VR ENGINE

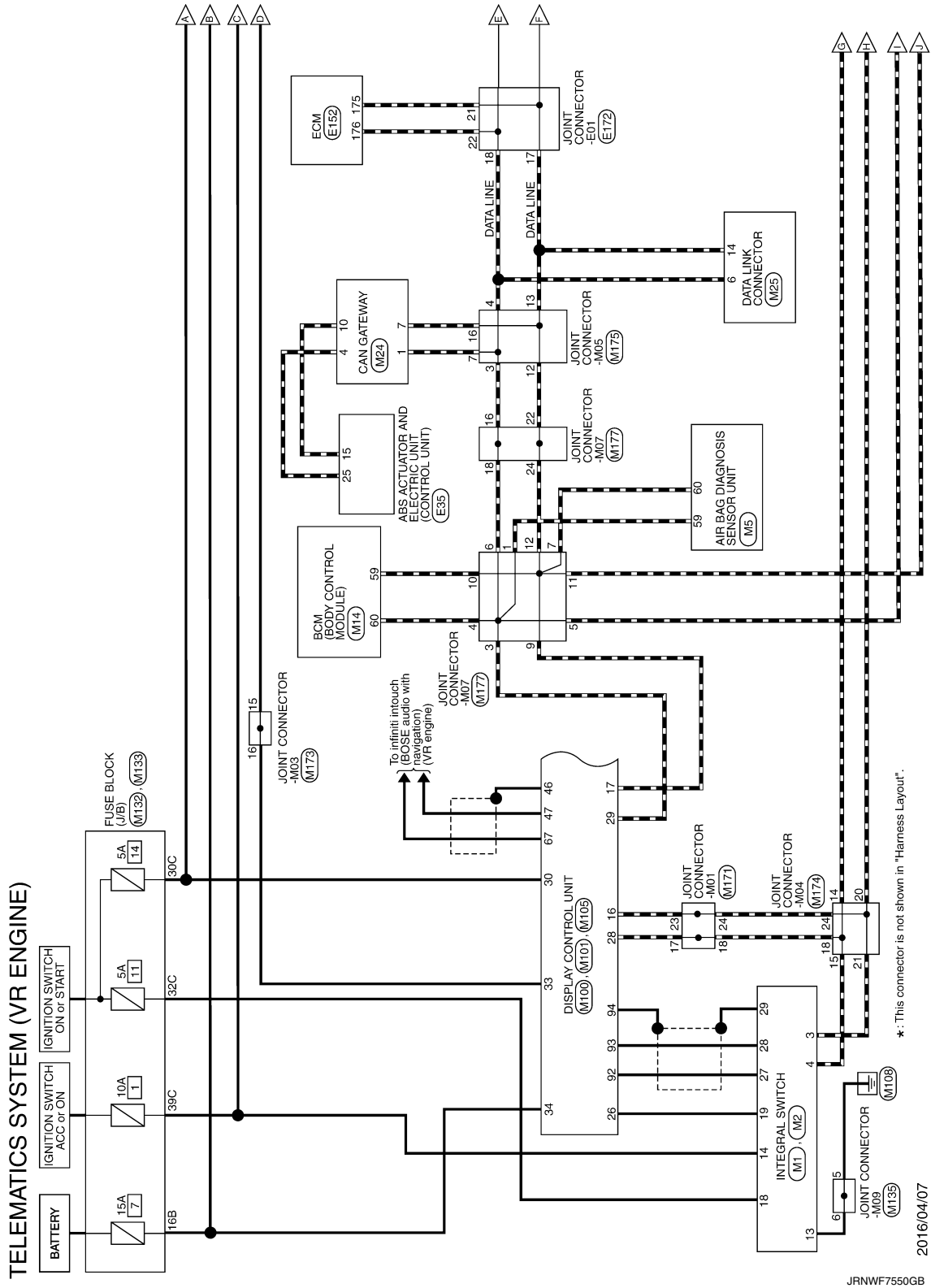

# TELEMATICS SYSTEM

< WIRING DIAGRAM >

[TELEMATICS SYSTEM]

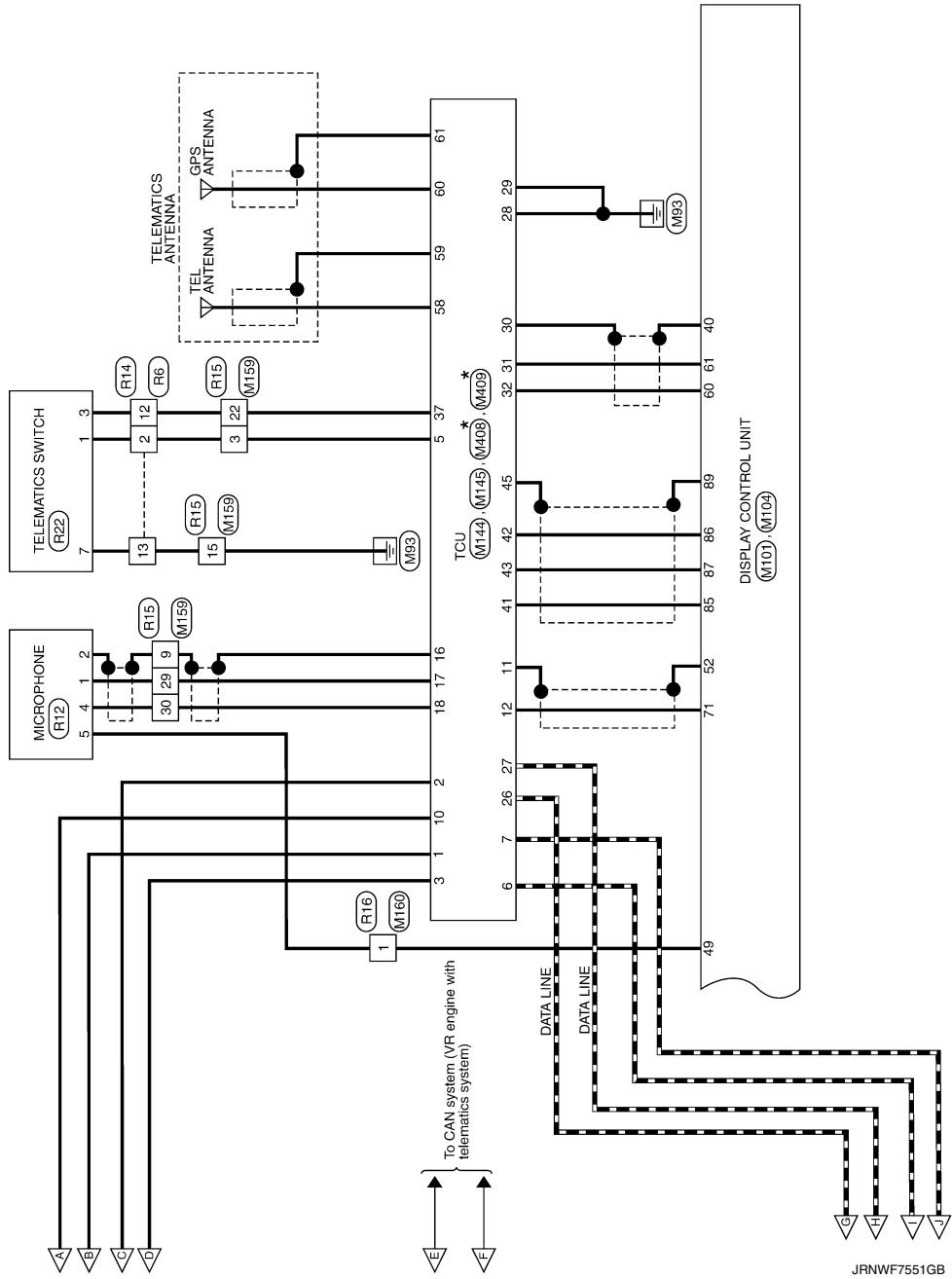

A  
B  
C  
D  
E  
F  
G  
H  
I  
J  
K  
L  
M  
N  
O  
P

AV

# TELEMATICS SYSTEM

< WIRING DIAGRAM >

[TELEMATICS SYSTEM]

## TELEMATICS SYSTEM (VR ENGINE)

Connector No.	E35
Connector Name	ABS ACTUATOR AND ELECTRIC UNIT (CONTROL UNIT)
Connector Type	SAZ20FB-S124-U

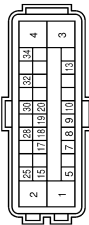

Terminal No.	Color	Wire	Signal Name [Specification]
1	B	B	GROUND
2	B	B	GROUND
3	P	P	VALVE BATTERY [With VR30 engine]
3	P	P	VALVE BATTERY [With 2.0L turbo gasoline engine]
4	Y	Y	MOTOR BATTERY
5	LG	LG	STOP LAMP SW SIGNAL [With ADAS]
5	V	V	STOP LAMP SW SIGNAL [With ASCD]
7	GR	GR	RR LH WHEEL SENSOR SIGNAL
8	G	G	RR LH WHEEL SENSOR POWER SUPPLY
9	BR	BR	FR RH WHEEL SENSOR SIGNAL
10	GR	GR	FR RH WHEEL SENSOR POWER SUPPLY
13	R	R	VACUUM SENSOR SIGNAL
15	P	P	CAN-L [Without Gateway]
15	R	R	CAN-L [With Gateway]
17	Y	Y	RR RH WHEEL SENSOR SIGNAL
18	LG	LG	RR RH WHEEL SENSOR POWER SUPPLY [With 2.0L turbo gasoline engine]
18	V	V	RR RH WHEEL SENSOR POWER SUPPLY [With VR30 engine]
19	SB	SB	FR LH WHEEL SENSOR SIGNAL
20	BG	BG	FR LH WHEEL SENSOR POWER SUPPLY
25	L	L	CAN-H
28	G	G	VACUUM SENSOR POWER SUPPLY
30	R	R	VDC OFF SW SIGNAL
32	SHIELD	SHIELD	VACUUM SENSOR GROUND
34	G	G	IGN

Connector No.	E152
Connector Name	ECM
Connector Type	RH24FB-R28-L-RH

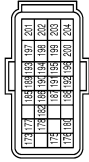

Terminal No.	Color	Wire	Signal Name [Specification]
173	SB	SB	FUEL TANK PRESSURE SENSOR
175	P	P	CAN-L
176	L	L	CAN-H
177	G	G	SENSOR POWER SUPPLY (FUEL TANK PRESSURE SENSOR)
178	V	V	TACHO METER SIGNAL
180	P	P	FUEL TANK TEMPERATURE SENSOR
182	W	W	FUEL PUMP CONTROL MODULE (FPCM) CHECK
185	SB	SB	IGNITION SWITCH
186	SB	SB	ASCD STEERING SWITCH
187	BG	BG	SENSOR GROUND (ASCD STEERING SWITCH)
188	Y	Y	FUEL PUMP CONTROL MODULE (FPCM)
189	Y	Y	ENGINE COMMUNICATION LINE-L
190	L	L	ENGINE COMMUNICATION LINE-H
191	P	P	STOP LAMP SWITCH
192	BG	BG	BRAKE PEDAL POSITION SWITCH
193	GR	GR	EVAP CANISTER VENT CONTROL VALVE
194	W	W	SENSOR POWER SUPPLY
195	BR	BR	ACCELERATOR PEDAL POSITION SENSOR 2
196	R	R	SENSOR GROUND (ACCELERATOR PEDAL POSITION SENSOR 2)
197	R	R	ECM POWER SUPPLY
198	L	L	SENSOR POWER SUPPLY
199	B	B	ECM GROUND
200	V	V	SENSOR GROUND
201	B	B	ECM GROUND
202	Y	Y	ACCELERATOR PEDAL POSITION SENSOR 1
203	G	G	SENSOR GROUND
204	B	B	ECM GROUND

Connector No.	E172
Connector Name	JOINT CONNECTOR-E01
Connector Type	SGA28F1BR-J



Terminal No.	Color	Wire	Signal Name [Specification]
1	GR	GR	-
2	Y	Y	-
3	W	W	-
4	L	L	-
5	GR	GR	-
6	Y	Y	-
7	W	W	-
8	L	L	-
9	GR	GR	-
10	Y	Y	-
11	W	W	-
12	L	L	-
15	W	W	-
16	BG	BG	-
17	P	P	-
18	L	L	-
19	W	W	-
20	BG	BG	-
21	P	P	-
22	L	L	-
23	SB	SB	-
24	LG	LG	-
25	P	P	-
26	L	L	-

Connector No.	M1
Connector Name	INTEGRAL SWITCH
Connector Type	TH24FW-WH

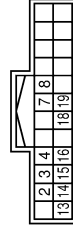

Terminal No.	Color	Wire	Signal Name [Specification]
2	R	R	ILLUMINATION SIGNAL
3	LG	LG	AV COMMUNICATION SIGNAL (L)
4	SB	SB	AV COMMUNICATION SIGNAL (H)
7	W/B	W/B	DISK EJECT SIGNAL
8	G	G	HAZARD SIGNAL
13	B	B	GROUND
14	SB	SB	ACC POWER SUPPLY [With 2.0L turbo gasoline engine]
14	V	V	ACC POWER SUPPLY [With VR30 engine]
15	B	B	ILLUMINATION CONTROL SIGNAL
16	BG	BG	DISK EJECT SIGNAL GROUND
18	R	R	IGNITION SIGNAL [With VR30 engine]
18	W	W	IGNITION SIGNAL [With 2.0L turbo gasoline engine]
19	BR	BR	CAMERA SWITCH SIGNAL

Connector No.	M2
Connector Name	INTEGRAL SWITCH
Connector Type	Tvco_1554-987-6



Terminal No.	Color	Wire	Signal Name [Specification]
27	W	W	LWDS (+)
28	B	B	LWDS (-)
29	SHIELD	SHIELD	SHIELD

## TELEMATICS SYSTEM (VR ENGINE)

Connector No.	M5
Connector Name	AIR BAG DIAGNOSIS SENSOR UNIT
Connector Type	NH28FY-EX

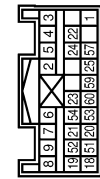

Terminal No.	Color Of Wire	Signal Name [Specification]
1	LG	IGN
2	B	GND
3	Y/R	DR1 (+)
4	Y/B	DR1 (-)
5	Y	DR2 (+)
6	Y/R	DR2 (-)
7	Y/B	AS1 (+)
8	Y/G	AS1 (-)
9	Y	AS2 (+)
18	Y	ECZ5 (+)
19	BR	ECZ5 (-)
20	Y/R	ACT VENT (+)
21	Y/B	ACT VENT (-)
22	SHIELD	GND
23	V	AIRBAG W/L
24	G	AIR OFF IND
25	GR	SATELLITE RH2 (+)
51	G	SIDE SENS RH2 (-)
53	R	SIDE SENS LH2 (+)
54	L	SIDE SENS LH2 (-)
57	LG	IVCS
59	L	CAN-H
60	P	CAN-L

Connector No.	M14
Connector Name	BCM (BODY CONTROL MODULE)
Connector Type	TH40FE-NH

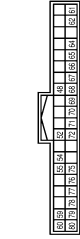

Terminal No.	Color Of Wire	Signal Name [Specification]
48	R	PUSH-BTN IGN SW LL PWR
52	G	DONGLE LINK
54	V	COMM LINE
55	R	RAIN SENSOR
59	P	CAN-L
60	L	CAN-H
61	G	REAR WINDOW DEF RLY CONT
62	R	STARTER RLY CONT
64	V	I-KEY WARN BUZZER
65	B	OUTS HD LAMP CONT
66	B	BLOWER FAN RLY CONT (WITH VR30 engine)
66	Y	BLOWER FAN RLY CONT (WITH 2.0L turbo gasoline engine)
67	W/B	IGN RLY (F/B) CONT
68	R	DIMMER
69	GR	A/T SHIFT SELECT PWR SPLY
70	B	IGN RLY (P/D/M/L/R) CONT
71	G	DR DOOR REQ SW
72	SB	PASS DOOR REQ SW
75	BR	COMBI SW INPUT 5
76	BG	COMBI SW INPUT 4
77	V	COMBI SW INPUT 3
78	Y	COMBI SW INPUT 2
79	LG	COMBI SW INPUT 1
80	L	TR LED OPNRS SW

Connector No.	M24
Connector Name	CAN GATEWAY
Connector Type	TH12FW-AH

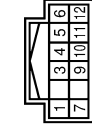

Terminal No.	Color Of Wire	Signal Name [Specification]
1	L	CAN-H [CAN COMMUNICATION CIRCUIT 1]
3	W	BATTERY POWER SUPPLY
4	L	CAN-H [CAN COMMUNICATION CIRCUIT 2]
5	B	GROUND
6	L	CAN-H [CAN COMMUNICATION CIRCUIT 2]
7	P	CAN-L [CAN COMMUNICATION CIRCUIT 1]
9	R	IGNITION POWER SUPPLY [WITH VR30 engine]
9	W	IGNITION POWER SUPPLY [WITH 2.0L turbo gasoline engine]
10	R	CAN-L [CAN COMMUNICATION CIRCUIT 2]
11	B	GROUND
12	R	CAN-L [CAN COMMUNICATION CIRCUIT 2]

Connector No.	M25
Connector Name	DATA LINK CONNECTOR
Connector Type	BD16FW

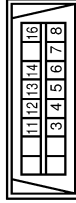

Terminal No.	Color Of Wire	Signal Name [Specification]
3	IG	M CAN L
4	B	EARTH
5	B	EARTH
6	L	CAN-H
7	V	KLINE [With 2.0L turbo gasoline engine]
7	W	KLINE [With VR30 engine]
8	W	IGN_SW
11	SB	M CAN H
12	R	CAN-L

Terminal No.	13	L	CAN-H
Terminal No.	14	P	CAN-L
Terminal No.	15	W	POWER

Connector No.	M100
Connector Name	DISPLAY CONTROL UNIT
Connector Type	TH24FW-NH

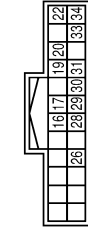

Terminal No.	Color Of Wire	Signal Name [Specification]
16	LG	AV COMMUNICATION SIGNAL (L)
16	P	CAN-L
17	P	DIMMER SIGNAL
19	R	REVERSE SIGNAL
20	BR	GROUND
22	B	CAMERA SWITCH SIGNAL
26	SB	AV COMMUNICATION SIGNAL (H)
28	BR	CAN-H
29	L	IGNITION SIGNAL [With VR30 engine]
30	W	IGNITION SIGNAL [With 2.0L turbo gasoline engine]
31	R	VEHICLE SPEED SIGNAL (B-PULSE)
33	SB	ACC POWER SUPPLY
34	Y	BATTERY POWER SUPPLY

Connector No.	M101
Connector Name	DISPLAY CONTROL UNIT
Connector Type	TH40FW-NH

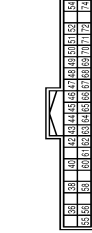

A  
B  
C  
D  
E  
F  
G  
H  
I  
J  
K  
L  
M  
N  
O  
P

AV

## TELEMATICS SYSTEM (VR ENGINE)

Terminal No.	Color Of Wire	Signal Name [Specification]
36	LG	COMPOSITE IMAGE SIGNAL (-)
38	SHIELD	SHIELD
40	SHIELD	MANUFACTURER SPECIFIC SIGNAL
42	G	SOUND SIGNAL RH (-)
43	SHIELD	SHIELD
44	L	SOUND SIGNAL LH (-)
45	W	TEL VOICE SIGNAL (-)
46	SHIELD	SHIELD
47	R	VOICE GUIDANCE SIGNAL OUTPUT (-)
48	B	VOICE GUIDANCE SIGNAL INPUT (-)
49	W	NS ON/OFF SIGNAL
50	R	MICROPHONE SIGNAL GROUND (WITH NAVIGATION)
51	SHIELD	SHIELD
52	SHIELD	MICROPHONE SIGNAL GROUND
54	W	CAMERA POWER SUPPLY GROUND
55	SHIELD	SHIELD
56	BR	COMPOSITE IMAGE SIGNAL (+)
58	B	CAMERA IMAGE SIGNAL
60	W	SOUND SIGNAL (-)
61	B	SOUND SIGNAL (+)
62	R	SOUND SIGNAL RH (+)
63	SHIELD	SHIELD
64	V	SOUND SIGNAL LH (+)
65	B	TEL VOICE SIGNAL (+)
66	SHIELD	SHIELD
67	G	VOICE GUIDANCE SIGNAL OUTPUT (+)
68	W	VOICE GUIDANCE SIGNAL INPUT (+)
69	SHIELD	SHIELD
70	G	MICROPHONE SIGNAL (NAV)
71	G	MICROPHONE SIGNAL (without telematics system)
71	R	MICROPHONE SIGNAL (with telematics system)
72	L	MICROPHONE VCC
74	R	CAMERA POWER SUPPLY

Connector No.	M104
Connector Name	DISPLAY CONTROL UNIT
Connector Type	USCAR30-MCF



Terminal No.	Color Of Wire	Signal Name [Specification]
85	R	USB V BUS SIGNAL
86	P	USED-SIGNAL
87	W	USED+ SIGNAL
89	SHIELD	USB GROUND

Connector No.	M105
Connector Name	DISPLAY CONTROL UNIT
Connector Type	Tvcp_1554987-6



Terminal No.	Color Of Wire	Signal Name [Specification]
92	W	LVDS (+)
93	B	LVDS (-)
94	SHIELD	SHIELD

Connector No.	M132
Connector Name	FUSE BLOCK (J/B)
Connector Type	NS16FW-CS



Terminal No.	Color Of Wire	Signal Name [Specification]
11B	LG	-
11B	P	-
14B	G	-
15B	Y	-
16B	Y	-
2B	B	-
4B	W	-
5B	R	-
9B	Y	-

Connector No.	M133
Connector Name	FUSE BLOCK (J/B)
Connector Type	TH40FW-AH

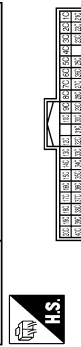

Terminal No.	Color Of Wire	Signal Name [Specification]
10C	V	-
13C	L	-
13C	L	-
14C	Y	-
15C	R	-
17C	L	-
18C	B	- [Without DRPO]
18C	P	- [With DRPO]
19C	B	-
1C	R	-

20C	W	-
21C	L	-
22C	L	-
23C	L	-
25C	LG	-
26C	SB	-
27C	P	-
28C	W	-
29C	W	-
30C	R	-
30C	R	-
31C	W	-
32C	R	-
33C	B	- [With VR3D engine]
33C	R	- [With 2.0L turbo gasoline engine]
34C	W/B	-
35C	SB	-
36C	R	-
37C	W	-
38C	SB	-
39C	V	-
3C	P	-
40C	G	-
4C	P	-
5C	P	-
6C	G	-
7C	G	-
8C	G	-
9C	V	-

Connector No.	M135
Connector Name	JOINT CONNECTOR-M09
Connector Type	24342_4GAA2



Terminal No.	Color Of Wire	Signal Name [Specification]
1	B	-
2	B	-
3	B	-
4	B	-
5	B	-

TELEMATICS SYSTEM (VR ENGINE)

6	B	-	-	-	-
9	LG	-	-	-	-
10	LG	-	-	-	-
11	LG	-	-	-	-
13	B	-	-	-	-
13	SB	-	-	-	- [With VR30 engine]
14	B	-	-	-	- [With VR30 engine]
14	SB	-	-	-	- [With VR30 engine]
15	B	-	-	-	- [With VR30 engine]
15	SB	-	-	-	- [With VR30 engine]
16	B	-	-	-	- [With VR30 engine]
16	SB	-	-	-	- [With VR30 engine]
17	SB	-	-	-	- [With VR30 engine]
17	Y	-	-	-	- [With VR30 engine]
18	SB	-	-	-	- [With VR30 engine]
18	Y	-	-	-	- [With VR30 engine]
19	SHIELD	-	-	-	-
20	R	-	-	-	-
21	R	-	-	-	-
22	SHIELD	-	-	-	-
23	L	-	-	-	-
24	L	-	-	-	-

Connector No.	M144
Connector Name	TCU
Connector Type	TH40P/BNH



Terminal No.	Color Of Wire	Signal Name [Specification]
1	Y	BATTERY POWER SUPPLY
2	SB	ACC POWER SUPPLY [With 2.0L turbo gasoline engine]
2	V	ACC POWER SUPPLY [With VR30 engine]
3	SB	ACC OUTPUT
5	BR	SOS SWITCH-LED SIGNAL
6	L	CAN-L
7	P	CAN-R
10	R	IGNITION SIGNAL [With VR30 engine]
10	W	IGNITION SIGNAL [With 2.0L turbo gasoline engine]
11	SHIELD	MICROPHONE SIGNAL GROUND
12	R	MICROPHONE SIGNAL
16	SHIELD	SHIELD

17	G	MICROPHONE SIGNAL
18	L	MICROPHONE VCC
26	SB	AV COMMUNICATION SIGNAL (H)
27	LG	AV COMMUNICATION SIGNAL (L)
28	B	GROUND
29	B	GROUND
30	SHIELD	SHIELD
31	B	SOUND SIGNAL (A)
32	W	SOUND SIGNAL (L)
37	G	SOS CALL SWITCH SIGNAL

Connector No.	M145
Connector Name	TCU
Connector Type	USCAR30-MC-F



Terminal No.	Color Of Wire	Signal Name [Specification]
41	R	USB V BUS SIGNAL
42	P	USB D- SIGNAL
43	W	USB D+ SIGNAL
45	SHIELD	USB GROUND

Connector No.	M159
Connector Name	WIRE TO WIRE
Connector Type	TH40P/WH



Terminal No.	Color Of Wire	Signal Name [Specification]
1	G	-
2	B	-
3	BR	-
4	R	-

5	GR	-	-
6	W	-	-
9	SHIELD	-	-
10	W	-	-
11	R	-	-
12	L	-	-
13	G	-	-
14	W	-	- [With VR30 engine]
14	Y	-	- [With 2.0L turbo gasoline engine]
15	B	-	-
17	B	-	-
17	R	-	-
20	BS	-	-
20	BR	-	- [With VR30 engine and with BOSE system]
20	SB	-	- [With 2.0L turbo gasoline engine and without BOSE system]
21	R	-	-
22	G	-	-
24	B	-	-
25	W	-	-
26	R	-	-
28	B	-	-
29	G	-	-
30	L	-	-
31	R	-	-
32	W	-	-
36	V	-	-
38	LG	-	-
40	L	-	- [With 2.0L turbo gasoline engine and without BOSE system]
40	W	-	- [Except with 2.0L turbo gasoline engine and without BOSE system]



Connector No.	M160
Connector Name	WIRE TO WIRE
Connector Type	NS58W-CS



Terminal No.	Color Of Wire	Signal Name [Specification]
1	W	-
2	LG	-
3	BR	-
4	R	-

6	B	-
7	R	-
8	V	-

Connector No.	M171
Connector Name	JOINT CONNECTOR-M01
Connector Type	24342_4G2A



Terminal No.	Color Of Wire	Signal Name [Specification]
1	B	-
2	B	-
3	B	-
4	B	-
5	B	-
6	B	-
7	B	-
8	B	-
9	B	-
10	G	-
11	G	-
13	B	-
14	B	-
15	B	-
16	SB	- [With VR30 engine]
16	Y	- [With 2.0L turbo gasoline engine]
17	SB	- [With VR30 engine]
17	Y	- [With 2.0L turbo gasoline engine]
18	SB	- [With VR30 engine]
18	Y	- [With 2.0L turbo gasoline engine]
19	G	-
20	G	-
22	LG	- [With VR30 engine]
22	SB	- [With 2.0L turbo gasoline engine]
23	LG	- [With VR30 engine]
23	SB	- [With 2.0L turbo gasoline engine]
24	LG	- [With VR30 engine]
24	SB	- [With 2.0L turbo gasoline engine]

A  
B  
C  
D  
E  
F  
G  
H  
I  
J  
K  
L  
M  
N  
O  
P

AV

**TELEMATICS SYSTEM (VR ENGINE)**

Connector No.	M173
Connector Name	JOINT CONNECTOR-M03
Connector Type	24342_4GAZA

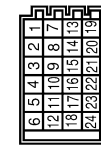

Terminal No.	Color Of Wire	Signal Name [Specification]
1	L	-
2	L	-
3	L	-
4	L	-
5	L	-
6	L	-
7	R	-
8	R	-
9	R	-
10	R	-
11	R	-
12	R	-
13	SB	-
14	SB	-
15	SB	-
16	L	- [With 2.0L turbo gasoline engine]
17	L	- [With VR30 engine]
18	L	- [With 2.0L turbo gasoline engine]
19	RR	- [With VR30 engine]
20	RR	- [With 2.0L turbo gasoline engine]
21	RR	- [With VR30 engine]
22	R	- [With 2.0L turbo gasoline engine]
23	R	- [With VR30 engine]
24	R	- [With 2.0L turbo gasoline engine]

Connector No.	M174
Connector Name	JOINT CONNECTOR-M04
Connector Type	24342_4GAZA



Terminal No.	Color Of Wire	Signal Name [Specification]
3	L	-
4	L	-
5	L	-
6	L	-
9	Y	-
10	Y	-
11	Y	-
12	Y	-
13	SB	-
14	SB	-
15	SB	-
16	SB	-
17	SB	-
18	SB	-
19	LG	-
20	LG	-
21	LG	-
22	LG	-
23	LG	-
24	LG	-

Connector No.	M175
Connector Name	JOINT CONNECTOR-M05
Connector Type	NH20FL-DC

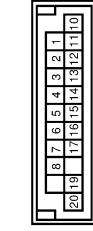

Terminal No.	Color Of Wire	Signal Name [Specification]
1	L	-
2	L	-
3	L	-
4	L	-
5	L	-
6	L	-
7	L	-
8	L	-
10	P	-
11	P	-
12	P	-
13	P	-
14	P	-
15	P	-
16	P	-
17	P	-
19	W	-
20	W	-

Connector No.	M177
Connector Name	JOINT CONNECTOR-M07
Connector Type	24342_4GAZA



Terminal No.	Color Of Wire	Signal Name [Specification]
1	L	-
3	L	-
4	L	-
5	L	-
6	L	-
7	P	-
9	P	-
10	P	-
11	P	-
12	P	-
13	L	-
17	L	-
18	L	-
22	P	-
23	P	-
24	P	-

Connector No.	M408
Connector Name	TCU
Connector Type	GT16C-1P-05



Terminal No.	Color Of Wire	Signal Name [Specification]
58	-	TEL ANTENNA SIGNAL
59	-	SHIELD

TELEMATICS SYSTEM (VR ENGINE)

Connector No.	M409
Connector Name	TCU
Connector Type	GT16CJP-05



Terminal No.	Color Of Wire	Signal Name [Specification]
60	-	GPS ANTENNA SIGNAL
61	-	SHIELD

Connector No.	R6
Connector Name	WIRE TO WIRE
Connector Type	TH16MW-NH



Terminal No.	Color Of Wire	Signal Name [Specification]
1	BG	- [With VR30 engine]
2	SB	- [With 2.0L turbo gasoline engine]
4	RR	-
6	V	-
7	R	-
8	G	-
9	L	- [With 2.0L turbo gasoline engine]
11	W	- [With VR30 engine]
12	LG	-
13	B	-

Connector No.	R12
Connector Name	MICROPHONE
Connector Type	ANGFW

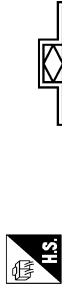

Terminal No.	Color Of Wire	Signal Name [Specification]
1	R	-
2	SHIELD	-
4	L	-
5	W	-

Connector No.	R14
Connector Name	WIRE TO WIRE
Connector Type	TH16FW-NH

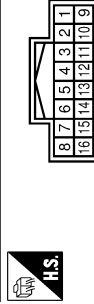

Terminal No.	Color Of Wire	Signal Name [Specification]
1	BG	- [With VR30 engine]
2	SB	- [With 2.0L turbo gasoline engine]
4	V	-
6	SB	-
7	R	-
8	G	-
9	L	- [With 2.0L turbo gasoline engine]
11	W	- [With VR30 engine]
12	LG	-
13	B	-

Connector No.	R15
Connector Name	WIRE TO WIRE
Connector Type	TH40MW-NH



Terminal No.	Color Of Wire	Signal Name [Specification]
1	G	-
2	LG	-
3	BR	-
4	V	-
5	BG	-
6	GR	-
9	SHIELD	-
10	GR	-
11	R	-
12	L	-
13	G	-
14	W	- [With VR30 engine]
14	Y	- [With 2.0L turbo gasoline engine]
15	B	-
17	SB	-
19	BG	-
20	BR	- [Without BOSE system]
20	BR	- [With BOSE system]
21	R	-
22	G	-
24	B	-
25	P	-
26	BR	-
28	B	-
29	R	-
30	L	-
31	V	-
32	W	-
33	L	-
36	BR	-
38	SB	-
40	W	-

Connector No.	R16
Connector Name	WIRE TO WIRE
Connector Type	NS98MW-CS



Terminal No.	Color Of Wire	Signal Name [Specification]
1	W	-
2	R	-
3	Y	-
4	W	-
6	B	-
7	GR	-
8	V	-

Connector No.	R22
Connector Name	TELEMATICS SWITCH
Connector Type	TH08FW-NH



Terminal No.	Color Of Wire	Signal Name [Specification]
1	V	-
3	G	-
5	SB	-
6	B	-
7	B	-

A  
B  
C  
D  
E  
F  
G  
H  
I  
J  
K  
L  
M  
N  
O  
P

AV

## BASIC INSPECTION

### DIAGNOSIS AND REPAIR WORK FLOW

#### Work Flow

INFOID:000000013717663

#### OVERALL SEQUENCE

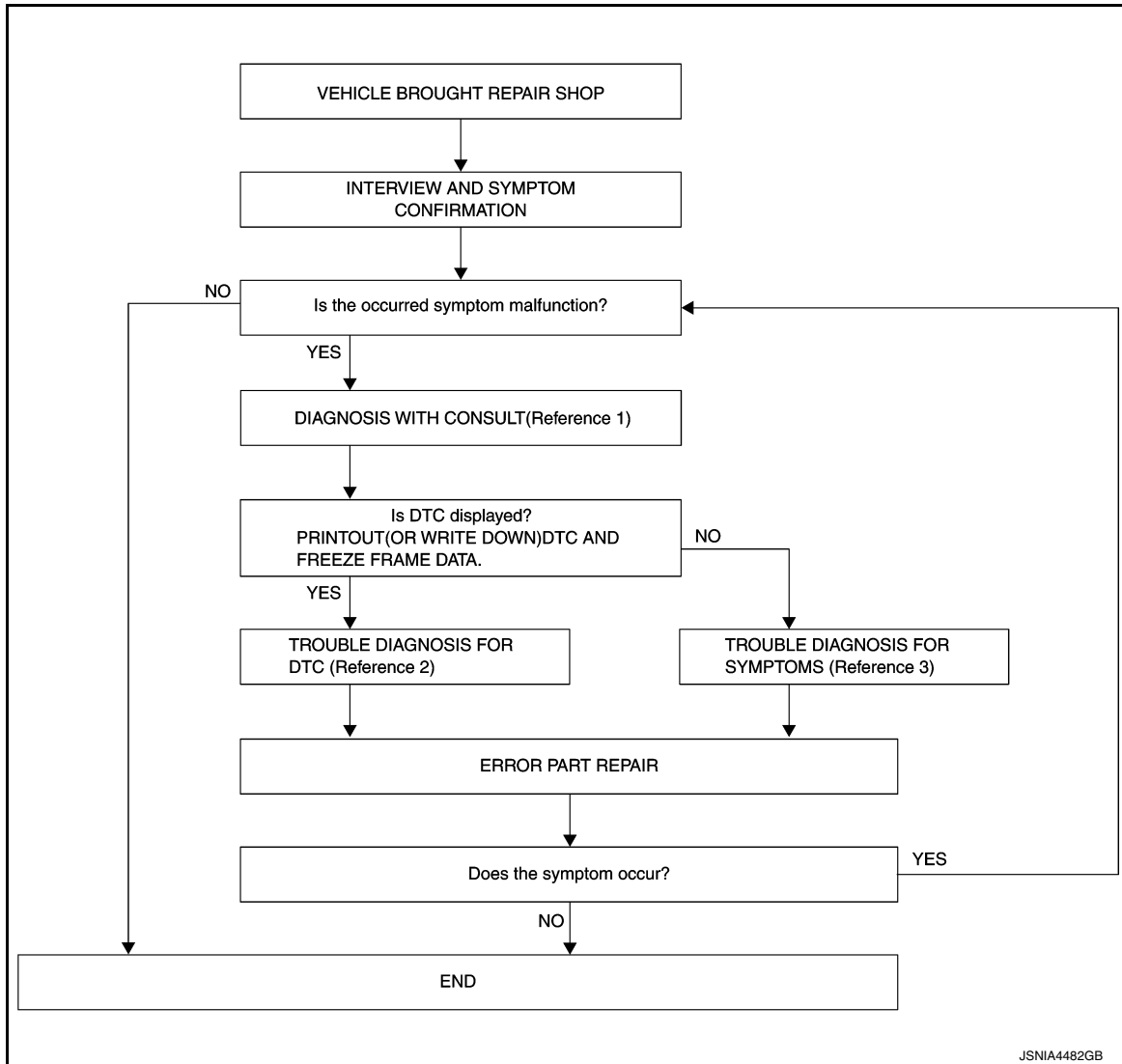

JSNIA4482GB

- Reference 1… Refer to [AV-741, "CONSULT Function"](#).
- Reference 2… Refer to [AV-746, "DTC Index"](#).
- Reference 3… Refer to [AV-795, "SYMPTOM TABLE"](#).

#### DETAILED FLOW

##### 1. INTERVIEW AND SYMPTOM CONFIRMATION

Check the malfunction symptoms by performing the following items.

- Interview the customer to obtain the malfunction information (conditions and environment when the malfunction occurred).
- Check the symptom.

##### Is the occurred symptom malfunction?

YES >> GO TO 2.

NO >> INSPECTION END

##### 2. DIAGNOSIS WITH CONSULT

# DIAGNOSIS AND REPAIR WORK FLOW

[TELEMATICS SYSTEM]

## < BASIC INSPECTION >

1. Connect CONSULT and perform a self-diagnosis for "TELEMATICS". Refer to [AV-741. "CONSULT Function"](#).
2. When DTC is detected, follow the instructions below:
  - Record DTC and Freeze Frame Data.

### Is DTC displayed?

- YES >> GO TO 3.  
NO >> GO TO 4.

## 3. TROUBLE DIAGNOSIS FOR DTC

1. Check the DTC indicated in the self-diagnosis results.
2. Perform the relevant diagnosis referring to the DTC Index. Refer to [AV-746. "DTC Index"](#).

>> GO TO 5.

## 4. TROUBLE DIAGNOSIS FOR SYMPTOMS

Perform the relevant diagnosis referring to the diagnosis chart by symptom. Refer to [AV-795. "SYMPTOM TABLE"](#).

>> GO TO 5.

## 5. ERROR PART REPAIR

1. Repair or replace the identified malfunctioning parts.
2. Perform a self-diagnosis for "TELEMATICS" with CONSULT.
3. Check that the symptom does not occur.

### Does the symptom occur?

- YES >> GO TO 1.  
NO >> INSPECTION END

A  
B  
C  
D  
E  
F  
G  
H  
I  
J  
K  
L  
M  
O  
P

AV

## ADDITIONAL SERVICE WHEN REPLACING TCU

### Description

INFOID:000000013717664

When TCU is replaced, TCU activation operation is required.

#### Preparation before activation operation

- Subscribe to telematics service
- Preregister user ID and password (can be performed from owner homepage)
- Since VIN data and vehicle specifications are not included in the TCU after replacement, it is required to write VIN data and vehicle specifications with CONSULT.

Refer to [AV-768, "Work Procedure"](#).

### Work Procedure

INFOID:000000013717665

#### 1. READING OF VIN DATA

##### Ⓜ WITH CONSULT

Select "SAVE VIN DATA", then "Start" on "SAVE VIN DATA" screen to save the VIN data stored in replaced TCU in CONSULT.

##### NOTE:

If it cannot be saved, writing operation must be performed manually.

>> GO TO 2.

#### 2. CHECKING TYPE ID

##### Ⓜ WITH CONSULT

1. Select "Before ECU Replacement" of "Read / Write Configuration".
2. Check that "Type ID" is displayed on CONSULT.

##### Is "Type ID" displayed?

YES >> GO TO 3.

NO >> GO TO 7.

#### 3. VERIFYING TYPE ID (1)

##### Ⓜ WITH CONSULT

Compare a "Type ID" displayed on the CONSULT screen with the one searched by using FAST (service parts catalogue) to check that these "Type ID" agree with each other.

##### NOTE:

For the "Type ID" searched by using FAST (service parts catalog), use the last five digits of the "Type ID".

>> GO TO 4.

#### 4. SAVING TYPE ID

##### Ⓜ WITH CONSULT

Save "Type ID" on CONSULT.

>> GO TO 5.

#### 5. TCU REPLACEMENT

Replace TCU. Refer to [AV-799, "Removal and Installation"](#).

>> GO TO 6.

#### 6. WRITING TYPE ID (AUTOMATIC WRITING)

##### Ⓜ WITH CONSULT

1. Select "After ECU Replacement" of "Re/programming, Configuration" or that of "Read / Write Configuration".
2. Select the "Type ID" agreeing with the one stored on CONSULT and the one searched by using FAST (service parts catalogue) to write the "Type ID" into the TCU.

# ADDITIONAL SERVICE WHEN REPLACING TCU

< BASIC INSPECTION >

[TELEMATICS SYSTEM]

>> GO TO 9.

## 7. TCU REPLACEMENT

Replace TCU. Refer to [AV-799. "Removal and Installation"](#).

>> GO TO 8.

## 8. WRITING TYPE ID (MANUAL WRITING)

Ⓜ WITH CONSULT

1. Select "Manual selection".
2. Select the "Type ID" searched by using FAST (service parts catalogue) to write the "Type ID" into the TCU.

**NOTE:**

For the "Type ID" searched by using FAST (service parts catalog), use the last five digits of the "Type ID".

>> GO TO 9.

## 9. NOTICE TO CARRIER ATX HELP DESK

Contact ATX help desk to notice the termination of replaced TCU and connection of new TCU. (VIN is required)

Can ID data be saved to CONSULT at 1st step?

YES >> GO TO 10.

NO >> GO TO 11.

## 10. AUTOMATIC WRITING OF VIN DATA TO TCU

Ⓜ WITH CONSULT

Select "WRITE VIN (SAVED DATA)", then "Start" at "WRITE VIN (SAVED DATA)" screen to write the VIN data saved in CONSULT into new TCU.

>> GO TO 12.

## 11. MANUAL WRITING OF VIN DATA TO TCU

Ⓜ WITH CONSULT

Select "WRITE VIN (MANUAL INPUT)", "WRITE VIN (MANUAL INPUT)" then "Start" on changing screen to write the VIN data saved into new TCU.

>> GO TO 12.

## 12. TCU ACTIVATION

Ⓜ WITH CONSULT

1. Wait for 5 seconds or more after turning the ignition switch ON.
2. Touch "TELEMATICS" on the CONSULT screen.
3. After performing System Call of CONSULT, touch the "Work support" tab.
4. On the "Work support" screen of CONSULT, select "TCU ACTIVATE SETTING" and touch "Start".
5. On the "TCU ACTIVATE SETTING" screen, touch "Start" to set to ON. Touch "End".
6. Exit from CONSULT.
7. Turn the ignition switch OFF.
8. Wait (at least 10 seconds) until the ignition switch indicator turns OFF to shut down TCU.

>> WORK END.

# DTC/CIRCUIT DIAGNOSIS

## B130D TCU

### DTC Description

INFOID:000000013717666

### DTC DETECTION LOGIC

DTC No.	CONSULT screen terms (Trouble diagnosis content)	DTC detection condition	
		Diagnosis condition	When ignition switch is ON.
B130D	TEL LINE OUT ERROR (Telephone line out error)	Signal (terminal)	Sound signal
		Threshold	—
		Diagnosis delay time	1 second or more
		Diagnosis condition	When ignition switch is ON.

### POSSIBLE CAUSE

Sound signal circuit

### FAIL-SAFE

Telematics system function stops

### DTC CONFIRMATION PROCEDURE

#### 1. PERFORM DTC CONFIRMATION PROCEDURE

 With CONSULT

1. Turn ignition switch ON.
2. Erase DTC using CONSULT.
3. Select "Self Diagnostic Result" mode of "TELEMATICS" using CONSULT.
4. Check DTC.

#### Is DTC B130D detected?

- YES >> Proceed to [AV-770, "Diagnosis Procedure"](#).
- NO-1 >> To check malfunction symptom before repair: Refer to [GI-44, "Intermittent Incident"](#).
- NO-2 >> Confirmation after repair: INSPECTION END

### Diagnosis Procedure

INFOID:000000013717667

#### 1. CHECK CONTINUITY BETWEEN TCU AND DISPLAY CONTROL UNIT CIRCUIT

1. Turn ignition switch OFF.
2. Disconnect TCU harness connector and display control unit harness connector.
3. Check continuity between TCU harness connector and display control unit harness connector.

TCU		Display control unit		Continuity
Connector	terminal	Connector	terminal	
M144	31	M101	61	Existed

4. Check continuity between TCU harness connector and ground.

TCU		Ground	Continuity
Connector	terminal		
M144	31		Not existed

#### Is the inspection result normal?

- YES >> GO TO 2.
- NO >> Repair or replace harness or connector.

#### 2. CHECK SOUND SIGNAL

1. Connect TCU harness connector and display control unit harness connector.

# B130D TCU

[TELEMATICS SYSTEM]

## < DTC/CIRCUIT DIAGNOSIS >

2. Turn ignition switch ACC.
3. Check signal between TCU harness connector terminals.

TCU			Condition	Reference value
Connector	(+)	(-)		
	Terminal			
M144	31	32	When inputting interior sound	

Is the inspection result normal?

- YES >> Replace TCU. Refer to [AV-799, "Removal and Installation"](#).  
 NO >> Replace display control unit. Refer to [AV-431, "Removal and Installation"](#).

A  
B  
C  
D  
E  
F  
G  
H  
I  
J  
K  
L  
M  
N  
O  
P

AV

**B1310 TCU**

**DTC Description**

INFOID:000000013717668

**DTC DETECTION LOGIC**

DTC No.	CONSULT screen terms (Trouble diagnosis content)	DTC detection condition	
B1310	TCU TEMPERATURE ERROR (TCU temperature error)	Diagnosis condition	When ignition switch is ON.
		Signal (terminal)	—
		Threshold	TCU internal temperature is high temperature
		Diagnosis delay time	1 second or more

**POSSIBLE CAUSE**

- TCU temperature is high
- TCU

**FAIL-SAFE**

Telematics system function stops

**DTC CONFIRMATION PROCEDURE**

**1.PERFORM DTC CONFIRMATION PROCEDURE**

 With CONSULT

1. Turn ignition switch ON.
2. Erase DTC using CONSULT.
3. Select "Self Diagnostic Result" mode of "TELEMATICS" using CONSULT.
4. Check DTC.

Is DTC B1310 detected?

- YES >> Proceed to [AV-772, "Diagnosis Procedure"](#).
- NO-1 >> To check malfunction symptom before repair: Refer to [GI-44, "Intermittent Incident"](#).
- NO-2 >> Confirmation after repair: INSPECTION END

**Diagnosis Procedure**

INFOID:000000013717669

**1.CHECK AROUND TCU**

Check whether there is any factor which causes a temperature rise near TCU.

Was there any factor?

- YES >> Remove a factor.
- NO >> GO TO 2.

**2.PERFORM DTC CONFIRMATION PROCEDURE AGAIN**

Perform DTC confirmation procedure again. Refer to [AV-772, "DTC Description"](#).

Is DTC B1310 detected again?

- YES >> Replace TCU. Refer to [AV-799, "Removal and Installation"](#).
- NO >> INSPECTION END

B13D9 TCU

DTC Description

INFOID:000000013717670

DTC DETECTION LOGIC

DTC No.	CONSULT screen terms (Trouble diagnosis content)	DTC detection condition	
		Diagnosis condition	When ignition switch is ON.
B13D9	USB CONNECTION (USB connection)	Signal (terminal)	USB communication signal
		Threshold	—
		Diagnosis delay time	1 second or more

POSSIBLE CAUSE

- USB harness
- TCU

FAIL-SAFE

Telematics system does not function

DTC CONFIRMATION PROCEDURE

1. PERFORM DTC CONFIRMATION PROCEDURE

☑ With CONSULT

1. Turn ignition switch ON.
2. Erase DTC using CONSULT.
3. Select "Self Diagnostic Result" mode of "TELEMATICS" using CONSULT.
4. Check DTC.

Is DTC B13D9 detected?

- YES >> Proceed to [AV-773, "Diagnosis Procedure"](#).
- NO-1 >> To check malfunction symptom before repair: Refer to [GI-44, "Intermittent Incident"](#).
- NO-2 >> Confirmation after repair: INSPECTION END

Diagnosis Procedure

INFOID:000000013717671

1. CHECK USB HARNESS CONNECTION

1. Turn ignition switch OFF.
2. Visually check USB harness connector between display control unit and TCU.

Is the inspection result normal?

- YES >> GO TO 2.
- NO >> Repair or replace USB harness.

2. PERFORM DTC CONFIRMATION PROCEDURE AGAIN

Perform DTC confirmation procedure again. Refer to [AV-773, "DTC Description"](#).

Is DTC B13D9 detected again?

- YES >> Replace TCU. Refer to [AV-799, "Removal and Installation"](#).
- NO >> INSPECTION END

A  
B  
C  
D  
E  
F  
G  
H  
I  
J  
K  
L  
M  
AV  
O  
P

## B13E1 TCU

### DTC Description

INFOID:000000013717672

### DTC DETECTION LOGIC

DTC No.	CONSULT screen terms (Trouble diagnosis content)	DTC detection condition	
B13E1	CAN COMMUNICATION (CAN communication)	Diagnosis condition	When ignition switch is ON.
		Signal (terminal)	AV communication signal
		Threshold	—
		Diagnosis delay time	1 second or more

### POSSIBLE CAUSE

- TCU
- AV communication circuit is open

### FAIL-SAFE

Some telematics system does not function

### DTC CONFIRMATION PROCEDURE

#### 1. PERFORM DTC CONFIRMATION PROCEDURE

#### With CONSULT

1. Turn ignition switch ON.
2. Erase DTC using CONSULT.
3. Select "Self Diagnostic Result" mode of "TELEMATICS" using CONSULT.
4. Check DTC.

#### Is DTC B13E1 detected?

- YES >> Proceed to [AV-774, "Diagnosis Procedure"](#).
- NO-1 >> To check malfunction symptom before repair: Refer to [GI-44, "Intermittent Incident"](#).
- NO-2 >> Confirmation after repair: INSPECTION END

### Diagnosis Procedure

INFOID:000000013717673

#### 1. CHECK AV COMMUNICATION CIRCUIT

1. Turn ignition switch OFF.
2. Disconnect display control unit harness connector and TCU harness connector.
3. Check the continuity between display control unit harness connector and TCU harness connector.

Display control unit		TCU		Continuity
Connector	Terminal	Connector	Terminal	
M100	16	M144	27	Existed
	28		26	

#### Is the inspection result normal?

- YES >> Replace TCU. Refer to [AV-799, "Removal and Installation"](#).
- NO >> Repair or replace harness or connector.

# B2E33 TELEMATICS SWITCH

< DTC/CIRCUIT DIAGNOSIS >

[TELEMATICS SYSTEM]

## B2E33 TELEMATICS SWITCH

### DTC Description

INFOID:000000013717674

### DTC DETECTION LOGIC

DTC No.	CONSULT screen terms (Trouble diagnosis content)	DTC detection condition	
B2E33	ECALL BUTTON (Ecall button)	Diagnosis condition	When ignition switch is ON.
		Signal (terminal)	SOS switch LED signal
		Threshold	—
		Diagnosis delay time	1 second or more

### POSSIBLE CAUSE

- Telematics switch signal circuit
- Telematics switch

### FAIL-SAFE

- Telematics system does not function (Only SOS call does not operate)
- Telematics switch LED indicator turn OFF

### DTC CONFIRMATION PROCEDURE

#### 1. PERFORM DTC CONFIRMATION PROCEDURE

☑ With CONSULT

1. Turn ignition switch ON.
2. Erase DTC using CONSULT.
3. Select "Self Diagnostic Result" mode of "TELEMATICS" using CONSULT.
4. Check DTC.

#### Is DTC B2E33 detected?

YES >> Proceed to [AV-775, "Diagnosis Procedure"](#).

NO-1 >> To check malfunction symptom before repair: Refer to [GI-44, "Intermittent Incident"](#).

NO-2 >> Confirmation after repair: INSPECTION END

### Diagnosis Procedure

INFOID:000000013717675

#### 1. CHECK SOS SWITCH LED SIGNAL

1. Turn ignition switch ACC.
2. Check the voltage between TCU harness connector and ground.

(+)		(-)	Condition	Voltage (Approx.)
TCU				
Connector	Terminal			
M144	5	Ground	When not illuminated LED lamp of SOS switch	12.0 V
			When illuminated LED lamp of SOS switch	0 V

#### Is the inspection result normal?

YES >> GO TO 2.

NO >> Replace TCU. Refer to [AV-799, "Removal and Installation"](#).

#### 2. CHECK SOS SWITCH LED SIGNAL CIRCUIT FOR OPEN

1. Turn ignition switch OFF.
2. Disconnect TCU harness connector and telematics switch harness connector.
3. Check the continuity between TCU harness connector and telematics switch harness connector.

## B2E33 TELEMATICS SWITCH

< DTC/CIRCUIT DIAGNOSIS >

[TELEMATICS SYSTEM]

TCU		Telematics switch		Continuity
Connector	Terminal	Connector	Terminal	
M144	5	R22	1	Existed

Is the inspection result normal?

YES >> GO TO 3.

NO >> Repair or replace harness or connector.

### 3.CHECK SOS SWITCH LED SIGNAL CIRCUIT FOR SHORT

Check the continuity between TCU harness connector and ground.

TCU		Ground	Continuity
Connector	Terminal		
M144	5		Existed

Is the inspection result normal?

YES >> Replace telematics switch. Refer to [AV-801, "Removal and Installation"](#).

NO >> Repair or replace harness or connector.

## U1000 CAN COMM CIRCUIT

### DTC Description

INFOID:000000013717676

#### DESCRIPTION

CAN (Controller Area Network) is a serial communication line for real-time application. It is an on-vehicle multiplex communication line with high data communication speed and excellent error detection ability. Many electronic control units are equipped onto a vehicle, and each control unit shares information and links with other control units during operation (not independently). In CAN communication, control units are connected with 2 communication lines (CAN-H, CAN-L) allowing a high rate of information transmission with less wiring. Each control unit transmits/receives data but selectively reads required data only.

CAN Communication Signal Chart. Refer to [LAN-68, "CAN COMMUNICATION SYSTEM : CAN Communication Signal Chart \(VR30DDTT Engine Models\)"](#) (VR30DDTT engine models) or [LAN-61, "CAN COMMUNICATION SYSTEM : CAN Communication Signal Chart \(2.0L Turbo Gasoline Engine Models\)"](#) (2.0L turbo gasoline engine models).

#### DTC DETECTION LOGIC

DTC No.	CONSULT screen terms (Trouble diagnosis content)	DTC detection condition	
		Diagnosis condition	When ignition switch is ON.
U1000	CAN COMM CIRCUIT (CAN communication circuit)	Signal (terminal)	CAN communication signal
		Threshold	—
		Diagnosis delay time	2 seconds or more

#### POSSIBLE CAUSE

CAN communication system

#### FAIL-SAFE

Telematics system does not function

#### DTC CONFIRMATION PROCEDURE

##### 1. PERFORM DTC CONFIRMATION PROCEDURE

Ⓜ With CONSULT

1. Turn ignition switch ON.
2. Erase DTC using CONSULT.
3. Select "Self-Diagnostic Result" mode of "TELEMATICS" using CONSULT.
4. Check DTC.

Is DTC U1000 detected?

- YES >> Proceed to [AV-777, "Diagnosis Procedure"](#).
- NO-1 >> To check malfunction symptom before repair: [GI-44, "Intermittent Incident"](#).
- NO-2 >> Confirmation after repair: INSPECTION END

#### Diagnosis Procedure

INFOID:000000013717677

##### 1. PERFORM DTC CONFIRMATION PROCEDURE AGAIN

Perform DTC confirmation procedure again. Refer to [AV-777, "DTC Description"](#).

Is DTC U1000 detected again?

- YES >> Perform the trouble diagnosis for CAN communication system. Refer to [LAN-37, "Trouble Diagnosis Flow Chart"](#).
- NO >> INSPECTION END

## U1010 CONTROL UNIT (CAN)

### DTC Description

INFOID:000000013717678

#### DESCRIPTION

CAN controller controls the communication of CAN communication signal and the error detection.

#### DTC DETECTION LOGIC

DTC No.	CONSULT screen terms (Trouble diagnosis content)	DTC detection condition	
U1010	CONTROL UNIT (CAN) [Control unit (CAN)]	Diagnosis condition	When ignition switch is ON.
		Signal (terminal)	—
		Threshold	Initial diagnosis abnormality of the TCU CAN controller
		Diagnosis delay time	1 second or more

#### POSSIBLE CAUSE

TCU

#### FAIL-SAFE

Telematics system function stops

#### DTC CONFIRMATION PROCEDURE

### 1. PERFORM DTC CONFIRMATION PROCEDURE

#### With CONSULT

1. Turn ignition switch ON.
2. Erase DTC using CONSULT.
3. Select "Self-Diagnostic Result" mode of "TELEMATICS" using CONSULT.
4. Check DTC.

#### Is DTC U1010 detected?

- YES >> Proceed to [AV-778, "Diagnosis Procedure"](#).
- NO-1 >> To check malfunction symptom before repair: [GI-44, "Intermittent Incident"](#).
- NO-2 >> Confirmation after repair: INSPECTION END

#### Diagnosis Procedure

INFOID:000000013717679

### 1. PERFORM DTC CONFIRMATION PROCEDURE AGAIN

Perform DTC confirmation procedure again. Refer to [AV-778, "DTC Description"](#).

#### Is DTC U1010 detected again?

- YES >> Replace TCU. Refer to [AV-799, "Removal and Installation"](#).
- NO >> INSPECTION END

U1A00 TCU

DTC Description

INFOID:000000013717680

DTC DETECTION LOGIC

DTC No.	CONSULT screen terms (Trouble diagnosis content)	DTC detection condition	
		Diagnosis condition	When ignition switch is ON.
U1A00	ACC NO CONN (Accessory power supply circuit no connection)	Signal (terminal)	ACC power supply
		Threshold	No input
		Diagnosis delay time	1 second or more

POSSIBLE CAUSE

ACC power circuit

FAIL-SAFE

Telematics system does not function

DTC CONFIRMATION PROCEDURE

1.PERFORM DTC CONFIRMATION PROCEDURE

Ⓜ With CONSULT

1. Turn ignition switch ON.
2. Turn ignition switch OFF and wait at least 30 seconds.
3. Turn ignition switch ON and wait at least 30 seconds or more.
4. Select "Self Diagnostic Result" mode of "TELEMATICS" using CONSULT.
5. Check DTC.

Is DTC U1A00 detected?

- YES >> Proceed to [AV-779, "Diagnosis Procedure"](#).
- NO-1 >> To check malfunction symptom before repair: Refer to [GI-44, "Intermittent Incident"](#).
- NO-2 >> Confirmation after repair: INSPECTION END

Diagnosis Procedure

INFOID:000000013717681

1.CHECK ACC POWER CIRCUIT

Check the ACC power circuit. Refer to [AV-793, "TCU : Diagnosis Procedure"](#).

Is the inspection result normal?

- YES >> Replace TCU. Refer to [AV-799, "Removal and Installation"](#).
- NO >> Repair or replace malfunctioning parts.



U1A01 TCU

DTC Description

INFOID:000000013717682

DTC DETECTION LOGIC

DTC No.	CONSULT screen terms (Trouble diagnosis content)	DTC detection condition	
U1A01	INTERNAL ERROR (TCU) [Internal error (TCU)]	Diagnosis condition	When ignition switch is ON.
		Signal (terminal)	—
		Threshold	TCU internal malfunction
		Diagnosis delay time	1 second or more

POSSIBLE CAUSE

TCU

FAIL-SAFE

Telematics system function stops

DTC CONFIRMATION PROCEDURE

1. PERFORM DTC CONFIRMATION PROCEDURE

Ⓟ With CONSULT

1. Turn ignition switch ON.
2. Erase DTC using CONSULT.
3. Select "Self Diagnostic Result" mode of "TELEMATICS" using CONSULT.
4. Check DTC.

Is DTC U1A01 detected?

- YES >> Proceed to [AV-780, "Diagnosis Procedure"](#).
- NO-1 >> To check malfunction symptom before repair: Refer to [GI-44, "Intermittent Incident"](#).
- NO-2 >> Confirmation after repair: INSPECTION END

Diagnosis Procedure

INFOID:000000013717683

1. PERFORM DTC CONFIRMATION PROCEDURE AGAIN

Perform DTC confirmation procedure again. Refer to [AV-780, "DTC Description"](#).

Is DTC U1A01 detected again?

- YES >> Replace TCU. Refer to [AV-799, "Removal and Installation"](#).
- NO >> INSPECTION END

U1A03 TCU

DTC Description

INFOID:000000013717684

DTC DETECTION LOGIC

DTC No.	CONSULT screen terms (Trouble diagnosis content)	DTC detection condition	
		Diagnosis condition	When ignition switch is ON.
U1A03	SIM CARD (SIM card)	Signal (terminal)	—
		Threshold	—
		Diagnosis delay time	1 second or more

POSSIBLE CAUSE  
TCU

FAIL-SAFE

Telematics system function stops

DTC CONFIRMATION PROCEDURE

1.PERFORM DTC CONFIRMATION PROCEDURE

Ⓜ With CONSULT

1. Turn ignition switch ON.
2. Erase DTC using CONSULT.
3. Select "Self Diagnostic Result" mode of "TELEMATICS" using CONSULT.
4. Check DTC.

Is DTC U1A03 detected?

- YES >> Proceed to [AV-781, "Diagnosis Procedure"](#).
- NO-1 >> To check malfunction symptom before repair: Refer to [GI-44, "Intermittent Incident"](#).
- NO-2 >> Confirmation after repair: INSPECTION END

Diagnosis Procedure

INFOID:000000013717685

1.PERFORM DTC CONFIRMATION PROCEDURE AGAIN

Perform DTC confirmation procedure again. Refer to [AV-781, "DTC Description"](#).

Is DTC U1A03 detected again?

- YES >> Replace TCU. Refer to [AV-799, "Removal and Installation"](#).
- NO >> INSPECTION END

AV

## U1A04 TCU

## DTC Description

INFOID:000000013717686

## DTC DETECTION LOGIC

DTC No.	CONSULT screen terms (Trouble diagnosis content)	DTC detection condition	
		Diagnosis condition	When ignition switch is ON.
U1A04	VIN UNFINISHED (Vehicle identification number un- finished)	Signal (terminal)	—
		Threshold	Vehicle identification number is not written
		Diagnosis delay time	1 second or more

## POSSIBLE CAUSE

- VIN number is not written
- TCU

## FAIL-SAFE

Telematics service does not function

## DTC CONFIRMATION PROCEDURE

## 1. PERFORM DTC CONFIRMATION PROCEDURE

## ④ With CONSULT

1. Turn ignition switch ON.
2. Erase DTC using CONSULT.
3. Select "Self Diagnostic Result" mode of "TELEMATICS" using CONSULT.
4. Check DTC.

Is DTC U1A04 detected?

- YES >> Proceed to [AV-782, "Diagnosis Procedure"](#).  
 NO-1 >> To check malfunction symptom before repair: Refer to [GI-44, "Intermittent Incident"](#).  
 NO-2 >> Confirmation after repair: INSPECTION END

## Diagnosis Procedure

INFOID:000000013717687

## 1. PERFORM WRITING VIN DATA TO TCU

Perform writing VIN data to TCU. Refer to [AV-768, "Description"](#).Was the writing of VIN data completed?

- YES >> GO TO 2.  
 NO >> Replace TCU. Refer to [AV-799, "Removal and Installation"](#).

## 2. PERFORM DTC CONFIRMATION PROCEDURE AGAIN

Perform DTC confirmation procedure again. Refer to [AV-782, "DTC Description"](#).Is DTC U1A04 detected again?

- YES >> Replace TCU. Refer to [AV-799, "Removal and Installation"](#).  
 NO >> INSPECTION END

## U1A06 TEL ANTENNA

### DTC Description

INFOID:000000013717688

### DTC DETECTION LOGIC

DTC No.	CONSULT screen terms (Trouble diagnosis content)	DTC detection condition	
U1A06	TEL ANTENNA (TEL antenna)	Diagnosis condition	When ignition switch is ON.
		Signal (terminal)	TEL antenna signal
		Threshold	No input
		Diagnosis delay time	1 second or more

### POSSIBLE CAUSE

- TEL antenna signal circuit
- TEL antenna

### FAIL-SAFE

Telematics switch LED indicator turn OFF  
(LED indicator turns ON 10 times when push the SOS call switch.)

### DTC CONFIRMATION PROCEDURE

#### 1. PERFORM DTC CONFIRMATION PROCEDURE

With CONSULT

1. Turn ignition switch ON.
2. Erase DTC using CONSULT.
3. Select "Self Diagnostic Result" mode of "TELEMATICS" using CONSULT.
4. Check DTC.

#### Is DTC U1A06 detected?

- YES >> Proceed to [AV-783, "Diagnosis Procedure"](#).  
 NO-1 >> To check malfunction symptom before repair: Refer to [GI-44, "Intermittent Incident"](#).  
 NO-2 >> Confirmation after repair: INSPECTION END

### Diagnosis Procedure

INFOID:000000013717689

#### 1. CHECK TELEMATICS ANTENNA

Visually check telematics antenna and antenna feeder. Refer to [AV-803, "Feeder Layout"](#).

#### Is the inspection result normal?

- YES >> GO TO 2.  
 NO >> Repair malfunctioning parts.

#### 2. CHECK TCU VOLTAGE

1. Disconnect TCU harness connector.
2. Turn ignition switch ON.
3. Check voltage between TCU terminal and ground.

(+)	(-)	Voltage (Approx.)
TCU Terminal	Ground	5.0 V

#### Is the check result normal?

- YES >> Replace telematics antenna. Refer to [AV-802, "Removal and Installation"](#).  
 NO >> Replace TCU. Refer to [AV-799, "Removal and Installation"](#).

U1A09 GPS ANTENNA

DTC Description

INFOID:000000013717690

DTC DETECTION LOGIC

DTC No.	CONSULT screen terms (Trouble diagnosis content)	DTC detection condition	
U1A09	GPS ANTENNA CONN (GPS antenna connection)	Diagnosis condition	When ignition switch is ON.
		Signal (terminal)	GPS antenna signal
		Threshold	No input
		Diagnosis delay time	1 second or more

POSSIBLE CAUSE

- GPS antenna signal circuit
- GPS antenna

FAIL-SAFE

Telematics system cannot send correct position inform

DTC CONFIRMATION PROCEDURE

1. PERFORM DTC CONFIRMATION PROCEDURE

④ With CONSULT

1. Turn ignition switch ON.
2. Erase DTC using CONSULT.
3. Select "Self Diagnostic Result" mode of "TELEMATICS" using CONSULT.
4. Check DTC.

Is DTC U1A09 detected?

- YES >> Proceed to [AV-784, "Diagnosis Procedure"](#).  
 NO-1 >> To check malfunction symptom before repair: Refer to [GI-44, "Intermittent Incident"](#).  
 NO-2 >> Confirmation after repair: INSPECTION END

Diagnosis Procedure

INFOID:000000013717691

1. CHECK TELEMATICS ANTENNA

Visually check telematics antenna and antenna feeder. Refer to [AV-803, "Feeder Layout"](#).

Is the inspection result normal?

- YES >> GO TO 2.  
 NO >> Repair malfunctioning parts.

2. CHECK TCU VOLTAGE

1. Disconnect TCU harness connector.
2. Turn ignition switch ON.
3. Check voltage between TCU terminal and ground.

(+)	(-)	Voltage (Approx.)
TCU Terminal	Ground	5.0 V
60		

Is the check result normal?

- YES >> Replace telematics antenna. Refer to [AV-802, "Removal and Installation"](#).  
 NO >> Replace TCU. Refer to [AV-799, "Removal and Installation"](#).

U1A0A TCU

DTC Description

INFOID:000000013717692

DTC DETECTION LOGIC

DTC No.	CONSULT screen terms (Trouble diagnosis content)	DTC detection condition	
		Diagnosis condition	When ignition switch is ON.
U1A0A	GPS MODULE COMM (GPS module communication error)	Signal (terminal)	—
		Threshold	Malfunction on the GPS module in TCU
		Diagnosis delay time	1 second or more

POSSIBLE CAUSE

TCU

FAIL-SAFE

Telematics system cannot send correct position inform

DTC CONFIRMATION PROCEDURE

1.PERFORM DTC CONFIRMATION PROCEDURE

Ⓜ With CONSULT

1. Turn ignition switch ON.
2. Erase DTC using CONSULT.
3. Select "Self Diagnostic Result" mode of "TELEMATICS" using CONSULT.
4. Check DTC.

Is DTC U1A0A detected?

- YES >> Proceed to [AV-785, "Diagnosis Procedure"](#).
- NO-1 >> To check malfunction symptom before repair: Refer to [GI-44, "Intermittent Incident"](#).
- NO-2 >> Confirmation after repair: INSPECTION END

Diagnosis Procedure

INFOID:000000013717693

1.PERFORM DTC CONFIRMATION PROCEDURE AGAIN

Perform DTC confirmation procedure again. Refer to [AV-774, "DTC Description"](#).

Is DTC U1A0A detected again?

- YES >> Replace TCU. Refer to [AV-799, "Removal and Installation"](#).
- NO >> INSPECTION END



## U1A0B MICROPHONE

### DTC Description

INFOID:000000013717694

### DTC DETECTION LOGIC

DTC No.	CONSULT screen terms (Trouble diagnosis content)	DTC detection condition		
U1A0B	MIC IN CONN (Microphone input connection)	1	Diagnosis condition	When ignition switch is ON.
			Signal (terminal)	Microphone signal (between TCU and microphone)
			Threshold	Abnormality
			Diagnosis delay time	1 second or more
		2	Diagnosis condition	When ignition switch is ON.
			Signal (terminal)	Microphone VCC signal
			Threshold	Abnormality
			Diagnosis delay time	1 second or more

### POSSIBLE CAUSE

- Sound signal circuit
- Microphone VCC signal circuit

### FAIL-SAFE

Telematics service does not function

### DTC CONFIRMATION PROCEDURE

#### 1. PERFORM DTC CONFIRMATION PROCEDURE

④ With CONSULT

1. Turn ignition switch ON.
2. Erase DTC using CONSULT.
3. Select "Self Diagnostic Result" mode of "TELEMATICS" using CONSULT.
4. Check DTC.

#### Is DTC U1A0B detected?

- YES >> Proceed to [AV-786, "Diagnosis Procedure"](#).
- NO-1 >> To check malfunction symptom before repair: Refer to [GI-44, "Intermittent Incident"](#).
- NO-2 >> Confirmation after repair: INSPECTION END

### Diagnosis Procedure

INFOID:000000013717695

#### 1. CHECK MICROPHONE SIGNAL CIRCUIT

1. Turn ignition switch OFF.
2. Disconnect TCU harness connector and microphone harness connector.
3. Check the continuity between TCU harness connector and microphone harness connector.

TCU		Microphone		Continuity
Connector	Terminal	Connector	Terminal	
M144	16	R12	2	Existed
	17		1	
	18		4	

4. Check the continuity between TCU harness connector and ground.

# U1A0B MICROPHONE

< DTC/CIRCUIT DIAGNOSIS >

[TELEMATICS SYSTEM]

TCU		Ground	Continuity
Connector	Terminal		
M144	17		Not existed
	18		

Is the inspection result normal?

YES >> GO TO 2.

NO >> Repair or replace harness or connector.

## 2. CHECK VOLTAGE MICROPHONE POWER SUPPLY

1. Connect TCU harness connector.
2. Turn ignition switch ACC.
3. Check the voltage between TCU harness connector terminals.

TCU			Voltage (Approx.)
Connector	Terminal		
	(+)	(-)	
M144	18	16	5.0 V

Is the inspection result normal?

YES >> GO TO 3.

NO >> Replace TCU. Refer to [AV-799, "Removal and Installation"](#).

## 3. CHECK MICROPHONE SIGNAL

1. Connect microphone harness connector.
2. Check the signal between TCU harness connector terminals.

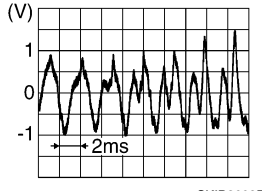
TCU			Condition	Reference value
Connector	(+)	(-)		
	Terminal			
M144	17	16	When inputting interior sound.	

Is the inspection result normal?

YES >> Replace TCU. Refer to [AV-799, "Removal and Installation"](#).

NO >> Replace microphone. Refer to [AV-800, "Removal and Installation"](#).

A  
B  
C  
D  
E  
F  
G  
H  
I  
J  
K  
L  
M

AV

# U1A0C MICROPHONE

< DTC/CIRCUIT DIAGNOSIS >

[TELEMATICS SYSTEM]

## U1A0C MICROPHONE

### DTC Description

INFOID:000000013717696

### DTC DETECTION LOGIC

DTC No.	CONSULT screen terms (Trouble diagnosis content)	DTC detection condition	
U1A0C	MIC OUT CONN (Microphone output connection)	Diagnosis condition	When ignition switch is ON.
		Signal (terminal)	Microphone signal (between TCU and AV control unit)
		Threshold	Abnormality
		Diagnosis delay time	1 second or more

### POSSIBLE CAUSE

Microphone signal circuit

### FAIL-SAFE

Transmit an own vehicle position to the INFINITI CONNECTION data center

### DTC CONFIRMATION PROCEDURE

#### 1.PERFORM DTC CONFIRMATION PROCEDURE

##### ④With CONSULT

1. Turn ignition switch ON.
2. Erase DTC using CONSULT.
3. Select "Self Diagnostic Result" mode of "TELEMATICS" using CONSULT.
4. Check DTC.

##### Is DTC U1A0C detected?

- YES >> Proceed to [AV-788. "Diagnosis Procedure"](#).  
NO-1 >> To check malfunction symptom before repair: Refer to [GI-44. "Intermittent Incident"](#).  
NO-2 >> Confirmation after repair: INSPECTION END

### Diagnosis Procedure

INFOID:000000013717697

#### 1.CHECK MICROPHONE SIGNAL CIRCUIT

1. Turn ignition switch OFF.
2. Disconnect TCU harness connector and display control unit connector.
3. Check the continuity between TCU harness connector and display control unit harness connector.

TCU		Display control unit		Continuity
Connector	Terminal	Connector	Terminal	
M144	11	M101	52	Existed
	12		71	

4. Check continuity between TCU harness connector and ground.

TCU		Ground	Continuity
Connector	Terminal		
M144	11		Not existed
	12		

##### Is the inspection result normal?

- YES >> GO TO 2.  
NO >> Repair or replace harness or connector.

#### 2.CHECK MICROPHONE SIGNAL

# U1A0C MICROPHONE

< DTC/CIRCUIT DIAGNOSIS >

[TELEMATICS SYSTEM]

1. Connect TCU harness connector and display control unit harness connector.
2. Turn ignition switch ACC.
3. Check the signal between TCU harness connector.

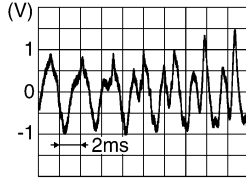
Connector	TCU		Condition	Reference value
	(+)	(-)		
	Terminal			
M144	12	11	When inputting interior sound.	 <p style="text-align: right; font-size: small;">SKIB3609E</p>

Is the inspection result normal?

- YES >> Replace display control unit. Refer to [AV-431, "Removal and Installation"](#).  
 NO >> Replace TCU. Refer to [AV-799, "Removal and Installation"](#).

A  
B  
C  
D  
E  
F  
G  
H  
I  
J  
K  
L  
M

AV

O  
P

# U1A0E TELEMATICS SWITCH

< DTC/CIRCUIT DIAGNOSIS >

[TELEMATICS SYSTEM]

## U1A0E TELEMATICS SWITCH

### DTC Description

INFOID:000000013717698

### DTC DETECTION LOGIC

DTC No.	CONSULT screen terms (Trouble diagnosis content)	DTC detection condition	
U1A0E	SOS SWITCH ON STUCK (SOS switch ON stuck)	Diagnosis condition	When ignition switch is ON.
		Signal (terminal)	SOS call switch signal
		Threshold	Continue being turned ON
		Diagnosis delay time	30 seconds or more

### POSSIBLE CAUSE

- SOS call switch signal circuit
- Sticking SOS call switch

### FAIL-SAFE

- Telematics system does not function (Only SOS call does not operate)
- Telematics switch LED indicator turn OFF

### DTC CONFIRMATION PROCEDURE

#### 1. PERFORM DTC CONFIRMATION PROCEDURE

##### With CONSULT

1. Turn ignition switch ON.
2. Erase DTC using CONSULT.
3. Turn ignition switch OFF.
4. Turn ignition switch ON and wait at least 30 seconds or more.
5. Select "Self Diagnostic Result" mode of "TELEMATICS" using CONSULT.
6. Check DTC.

##### Is DTC U1A0E detected?

- YES >> Proceed to [AV-790, "Diagnosis Procedure"](#).
- NO-1 >> To check malfunction symptom before repair: Refer to [GI-44, "Intermittent Incident"](#).
- NO-2 >> Confirmation after repair: INSPECTION END

### Diagnosis Procedure

INFOID:000000013717699

#### 1. CHECK SOS CALL SWITCH SIGNAL

1. Turn ignition switch ACC.
2. Check the voltage between TCU harness connector and ground as per the following condition.

(+)		(-)	Condition	Voltage (Approx.)
TCU				
Connector	Terminal			
M144	37	Ground	When pressing SOS switch	0 V
			Except for above	5.0 V

##### Is the inspection result normal?

- YES >> GO TO 2.
- NO >> Replace TCU. Refer to [AV-799, "Removal and Installation"](#).

#### 2. CHECK SOS CALL SWITCH SIGNAL CIRCUIT FOR OPEN

1. Turn ignition switch OFF.
2. Disconnect TCU harness connector and telematics switch harness connector.
3. Check the continuity between TCU harness connector and telematics switch harness connector.

# U1A0E TELEMATICS SWITCH

< DTC/CIRCUIT DIAGNOSIS >

[TELEMATICS SYSTEM]

TCU		Telematics switch		Continuity
Connector	Terminal	Connector	Terminal	
M144	37	R22	3	Existed

Is the inspection result normal?

YES >> GO TO 3.

NO >> Repair or replace harness or connector.

## 3.CHECK SOS CALL SWITCH SIGNAL CIRCUIT FOR SHORT

Check the continuity between TCU harness connector and ground.

TCU		Ground	Continuity
Connector	Terminal		
M144	37		Not existed

Is the inspection result normal?

YES >> Replace telematics switch. Refer to [AV-801, "Removal and Installation"](#).

NO >> Repair or replace malfunctioning parts.

A  
B  
C  
D  
E  
F  
G  
H  
I  
J  
K  
L  
M  
O  
P

AV

U1A10 TCU

DTC Description

INFOID:000000013717700

DTC DETECTION LOGIC

DTC No.	CONSULT screen terms (Trouble diagnosis content)	DTC detection condition	
U1A10	AIRBAG SIGNAL (Airbag signal)	Diagnosis condition	When ignition switch is ON.
		Signal (terminal)	Car crash information signal
		Threshold	Abnormality
		Diagnosis delay time	1 second or more

POSSIBLE CAUSE

Car crash information signal (CAN communication)

FAIL-SAFE

Some telematics system does not function

DTC CONFIRMATION PROCEDURE

1.PERFORM DTC CONFIRMATION PROCEDURE

ⓅWith CONSULT

1. Turn ignition switch ON.
2. Erase DTC using CONSULT.
3. Select "Self Diagnostic Result" mode of "TELEMATICS" using CONSULT.
4. Check DTC.

Is DTC U1A10 detected?

- YES >> Proceed to [AV-792. "Diagnosis Procedure"](#).
- NO-1 >> To check malfunction symptom before repair: Refer to [GI-44. "Intermittent Incident"](#).
- NO-2 >> Confirmation after repair: INSPECTION END

Diagnosis Procedure

INFOID:000000013717701

1.PERFORM DTC CONFIRMATION PROCEDURE AGAIN

Perform DTC confirmation procedure again. Refer to [AV-774. "DTC Description"](#)

Is DTC U1A10 detected again?

- YES >> Replace TCU. Refer to [AV-799. "Removal and Installation"](#).
- NO >> INSPECTION END

# POWER SUPPLY AND GROUND CIRCUIT

< DTC/CIRCUIT DIAGNOSIS >

[TELEMATICS SYSTEM]

## POWER SUPPLY AND GROUND CIRCUIT

### TCU

#### TCU : Diagnosis Procedure

INFOID:0000000013717704

#### 1.CHECK FUSE

Check if the fuse is burned out.

VR30DDTT

Power source	Fuse No.
Battery	#7
Ignition switch ACC or ON	#1
Ignition switch ON or START	#14

2.0L turbo gasoline engine

Power source	Fuse No.
Battery	#84
Ignition switch ACC or ON	#93
Ignition switch ON or START	#77

Is the inspection result normal?

YES >> GO TO 2.

NO >> Replace the fuse after repairing the applicable circuit.

#### 2.CHECK BATTERY POWER SUPPLY

Check the voltage between the TCU harness connector and ground.

(+)		(-)	Condition	Reference value (Approx.)
TCU				
Connector	Terminal			
M144	1	Ground	Ignition switch OFF	Battery Voltage

Is the inspection result normal?

YES >> GO TO 3.

NO >> Repair or replace harness between TCU and fuse.

#### 3.CHECK ACC POWER SUPPLY

1. Turn ignition switch ACC.
2. Check the voltage between the TCU harness connector and ground.

(+)		(-)	Condition	Reference value (Approx.)
TCU				
Connector	Terminal			
M144	2	Ground	Ignition switch ACC	12.0 V

Is the inspection result normal?

YES >> GO TO 4.

NO >> Repair or replace harness between TCU and fuse.

#### 4.CHECK IGNITION SIGNAL

1. Turn ignition switch ON.
2. Check the voltage between the TCU harness connector and ground.

A  
B  
C  
D  
E  
F  
G  
H  
I  
J  
K  
L  
M  
O  
P

AV

# POWER SUPPLY AND GROUND CIRCUIT

< DTC/CIRCUIT DIAGNOSIS >

[TELEMATICS SYSTEM]

(+)		(-)	Condition	Reference value (Approx.)
TCU				
Connector	Terminal			
M144	10	Ground	Ignition switch ON	12.0 V

Is the inspection result normal?

YES >> GO TO 5.

NO >> Repair or replace harness between TCU and fuse.

## 5. CHECK GROUND CIRCUIT

1. Turn ignition switch OFF.
2. Disconnect TCU harness connector.
3. Check the continuity between TCU harness connector and ground.

TCU		Ground	Continuity
Connector	Terminal		
M144	28		
	29		Existed

Is the inspection result normal?

YES >> INSPECTION END

NO >> Repair or replace TCU ground circuit.

**SYMPTOM DIAGNOSIS**

TELEMATICS SYSTEM

SYMPTOM TABLE

INFOID:000000013717705

INFINITI INTOUCH

Symptoms	Check items	Possible malfunction location/Action to take
Display control unit does not start (Display is not indicated).	—	Refer to <a href="#">AV-422. "Symptom Table"</a> .

TELEMATICS SYSTEM

A  
B  
C  
D  
E  
F  
G  
H  
I  
J  
K  
L  
M  
O  
P

AV

# TELEMATICS SYSTEM

< SYMPTOM DIAGNOSIS >

[TELEMATICS SYSTEM]

Symptoms	Check items	Indicator on SOS switch	Pop-up message	Possible malfunction location/Action to take
Telematics operation is not available.	Check the display when Telematics is operated.	OFF	No service.	<p>Check ON/OFF status of TCU using the data monitor of CONSULT.</p> <ul style="list-style-type: none"> <li>• Replace TCU if it is ON. Refer to <a href="#">AV-799, "Removal and Installation"</a>.</li> <li>• Turn it ON again if it is OFF. Replace TCU if ON is switched to OFF. Refer to <a href="#">AV-799, "Removal and Installation"</a>.</li> </ul>
				<p>Use other cellular phone to check radio wave condition.</p> <ul style="list-style-type: none"> <li>• If the service is available, replace TCU or TEL antenna.</li> <li>- For TCU replacement, refer to <a href="#">AV-799, "Removal and Installation"</a>.</li> <li>- For TEL antenna replacement, refer to <a href="#">AV-802, "Removal and Installation"</a>.</li> <li>• If the service is not available, move the vehicle to the position where service is available and perform the operation again. If guidance of "out of service area" appears when SOS switch is pressed even in the service area of cellular phone, confirm the SIM line contract status.</li> </ul>
				<p>Configuration is incomplete. Perform configuration of TCU. Refer to <a href="#">AV-768, "Description"</a>.</p>
		ON	Telematics communication is currently busy. Please try again later.	<p>Use other cellular phone to check radio wave condition.</p> <ul style="list-style-type: none"> <li>• If it is OK, there may be a cause at the Infiniti Connection™ Data Center. Check connection after certain time. If there is no problem at the Infiniti Connection™ Data Center, replace TCU or TEL antenna.</li> <li>- For TCU replacement, refer to <a href="#">AV-799, "Removal and Installation"</a>.</li> <li>- For TEL antenna replacement, refer to <a href="#">AV-802, "Removal and Installation"</a>.</li> <li>• If it is NG, check connection again after certain time.</li> </ul>
				<p>TCU line is using.</p> <p>Check connection after certain time. Replace TCU if it is frequently displayed. Refer to <a href="#">AV-799, "Removal and Installation"</a>.</p>
				<p>The connection to the call center failed.</p> <p>There may be a cause at the Infiniti Connection™ Data Center. Check connection after certain time. If there is no problem at the Infiniti Connection™ Data Center, replace TCU or TEL antenna.</p> <ul style="list-style-type: none"> <li>• For TCU replacement, refer to <a href="#">AV-799, "Removal and Installation"</a>.</li> <li>• For TEL antenna replacement, refer to <a href="#">AV-802, "Removal and Installation"</a>.</li> <li>• Perform CONSULT self-diagnosis. Refer to <a href="#">AV-741, "CONSULT Function"</a>.</li> </ul>
			"Please ask for initiation of service at your dealer"	Check the infiniti connection™ data base.
	<ul style="list-style-type: none"> <li>• No communication with Infiniti Connection™ Response service is available in Infiniti Connection™ service.</li> <li>• Other services are normal.</li> </ul>			Check the microphone signal circuit. Refer to <a href="#">AV-786, "Diagnosis Procedure"</a> or <a href="#">AV-788, "Diagnosis Procedure"</a> .

# NORMAL OPERATING CONDITION

< SYMPTOM DIAGNOSIS >

[TELEMATICS SYSTEM]

## NORMAL OPERATING CONDITION

### Description

INFOID:000000013717706

**NOTE:**

For Telematics system operation detail information, refer to Navigation system Owner's Manual.

### BASIC OPERATIONS

Symptom	Possible cause	Possible solution
No image is displayed.	The brightness is at the lowest setting.	Adjust the brightness of the display.
	The system in the video mode.	Press "" "AUX" to change the mode.
	The display is turned off.	Press "☀/☾" to turn on the display.
	The interior of the vehicle becomes the a little less than 80°C (176°F) or high temperature, and the protection of the display acts, and a display is turned off.	Wait until the interior of the vehicle has cooled down.
The screen is darker.	The cabin temperature is too low.	Wait until the interior of the vehicle temperature becomes moderate.
	The adjustment of display brightness is set to the maximum of darkness.	Adjust the brightness setting of the display.
The screen is brighter.	The adjustment of display brightness is set to the maximum of brightness.	
When looking at the screen from an angle, the screen lightens or darkens.	This is a typical phenomenon for liquid crystal displays.	
The screen is too dim. The movement is slow.	The temperature in the interior of the vehicle is less than 50°F (0°C).	Wait until the interior of the vehicle temperature becomes within 50°F(0°C) to 122°F (50°C).
The screen is too dim. The movement is slow.	The temperature in the interior of the vehicle is low.	Wait until the interior of the vehicle has warmed up.
No voice guidance is available. Or The volume is too high or too low.	The volume is not set correctly, or it is turned off.	Adjust the volume of voice guidance.
	Voice guidance is not provided for certain streets (roads displayed in gray).	This is not a malfunction.
No map is displayed on the screen.	A screen other than map screen is displayed.	Press "MAP".
Some pixels in the display are darker or brighter than others.	This condition is an inherent characteristic of liquid crystal displays.	This is not a malfunction.
Some menu items cannot be selected.	Some menu items become unavailable while the vehicle is driven.	Park the vehicle in a safe location, and then operate the navigation system.
A small black spot or a small bright spot appears on the screen.	This is a typical phenomenon for liquid crystal displays.	This is not a malfunction.
A dot or stripe pattern appears on the screen.	Electromagnetic wave that is generated from neon billboards, high voltage electric power cables, ham radios or other radio devices equipped to other vehicles may adversely affect the screen.	
Image lag appears on the screen.	This is a typical phenomenon for liquid crystal displays.	

**NOTE:**

Locations stored in the Address Book and other memory functions may be lost if the vehicle's battery is disconnected or becomes discharged. If this occurs, service the vehicle's battery as necessary and re-enter the information in the Address Book.

### RELATED TO CARWINGS™

## NORMAL OPERATING CONDITION

< SYMPTOM DIAGNOSIS >

[TELEMATICS SYSTEM]

Symptom	Possible cause	Possible solution
The system cannot connect to the INFINITI CONNECTION data center.	A subscription for the CARWINGS™ service has not been established.	Sign up for a subscription to the CARWINGS™ service. For details about subscriptions, contact a INFINITI dealer or visit the INFINITI CONNECTION data center website.
	The communication line is busy.	Try again after a short period of time.
	The vehicle is in a location where it is difficult to receive radio waves.	When the vehicle moves to an area where radio waves can be transmitted sufficiently, communication will be restored. When the icon on the display shows that the vehicle is inside the communication area, the system can be used.
	Radio wave reception for TCU is insufficient.	When the vehicle moves to an area where radio waves can be transmitted sufficiently, communication will be restored. When the icon on the display shows that the vehicle is inside the communication area, the system can be used.
Some of the items that are displayed on the menu screen cannot be selected.	The vehicle is being driven and some menu items are disabled.	The vehicle is being driven. Stop the vehicle in a safe location and apply the parking brake before operating the functions.
Some parts of the screen are not displayed	The vehicle is being driven and some menu items are disabled.	Operate the system after stopping the vehicle in a safe location and applying the parking brake.
The system does not announce information.	The volume level is set to the minimum.	Adjust the volume level by operating the VOL switches located on the control panel or on the steering wheel switch while the system is announcing information.

## REMOVAL AND INSTALLATION

## TCU

## Exploded View

INFOID:0000000013991344

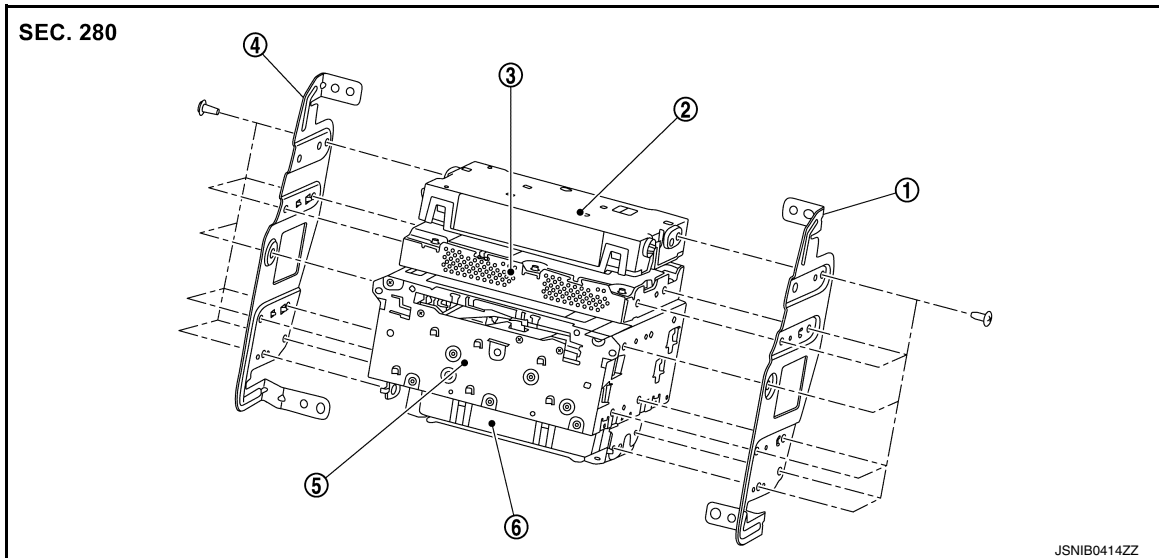

① Bracket RH

② A/C auto amp.

③ NAVI control unit

④ Bracket LH

⑤ AV control unit

⑥ TCU

## Removal and Installation

INFOID:0000000013717707

## REMOVAL

**CAUTION:**

Before replacing TCU, perform "Read/Write Configuration" to save or print current vehicle specification. For details, refer to [AV-768, "Description"](#).

1. Remove the integral switch. Refer to [AV-435, "Removal and Installation"](#).
2. Remove the bracket screws (A).
3. Disconnect the harness connector from the TCU (1).
4. Remove the bracket screws to remove the TCU.

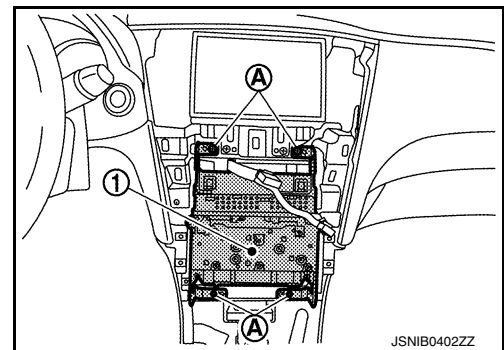

## INSTALLATION

Installation is in the reverse order of removal.

**CAUTION:**

Be sure to perform "Read/Write Configuration" when replacing TCU. For details, refer to [AV-768, "Description"](#).

## MICROPHONE

### Removal and Installation

INFOID:000000013717708

#### NOTE:

The microphone is integrated with the front microphone.

#### REMOVAL

1. Remove the map lamp assembly. Refer to [INL-76, "MAP LAMP : Removal and Installation"](#).
2. Disconnect the microphone connector (A).
3. Release the pawls to remove the microphone (1).

 : Pawl

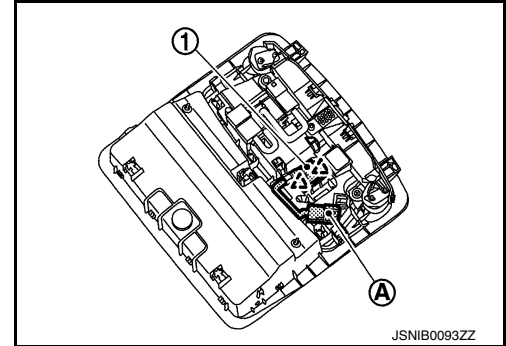

#### INSTALLATION

Installation is in the reverse order of removal.

## TELEMATICS SWITCH

### Removal and Installation

INFOID:000000013717709

#### REMOVAL

1. Remove the map lamp assembly. Refer to [INL-76, "MAP LAMP : Removal and Installation"](#).
2. Remove the connector (A) and screws (B).
3. Remove the telematics switch (1) with the map lamp assembly finisher as a single unit from the map lamp assembly.

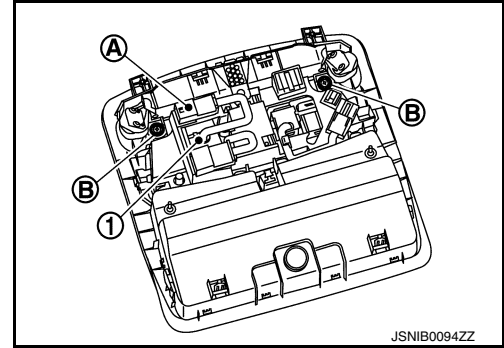

4. Remove the telematics switch (1), stretching pawls of the map lamp assembly finisher (2).

A : Removal tool

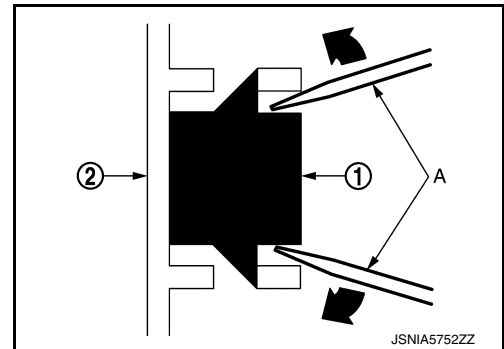

#### INSTALLATION

Installation is the reverse order of removal.

A  
B  
C  
D  
E  
F  
G  
H  
I  
J  
K  
L  
M  
O  
P

AV

## TELEMATICS ANTENNA

### Removal and Installation

INFOID:000000013717710

#### REMOVAL

1. Remove the instrument panel assembly. Refer to [IP-13. "Removal and Installation"](#).
2. Remove the screw **A** to remove the telematics antenna **1** from the instrument panel.

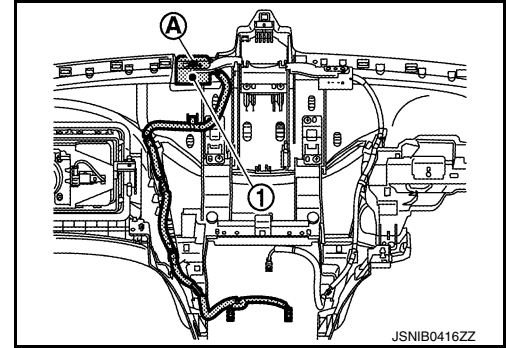

#### INSTALLATION

Install in the reverse order of removal.

## ANTENNA FEEDER

### Feeder Layout

INFOID:000000013717711

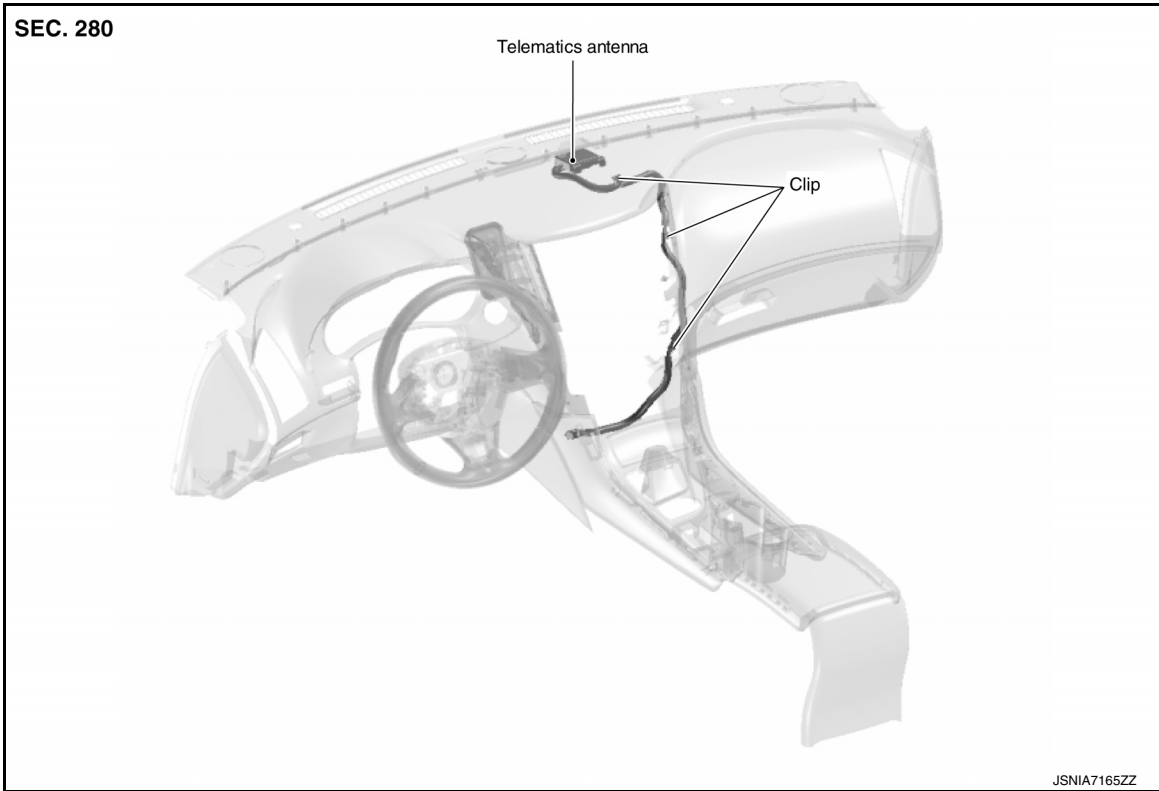

A

B

C

D

E

F

G

H

I

J

K

L

M

AV

O

P